

The Interstate Rest Areas Study: Along the I-29 and I-90 Corridors



September 2014



submitted to:



submitted by:



in association with:



**SOUTH DAKOTA DEPARTMENT
OF TRANSPORTATION
REST AREA STUDY:
ALONG THE I-29 AND I-90 CORRIDORS
FINAL REPORT**

Prepared for:

South Dakota Department of Transportation
Mr. Brad Remmich
Office of Project Development
700 East Broadway Avenue
Pierre, South Dakota 57501-2586
(605) 773-3093

Prepared by:

Felsburg Holt & Ullevig
6300 South Syracuse Way, Suite 600
Centennial, Colorado 80111
(303) 721-1440

TSP
600 Kansas City Street
Rapid City, South Dakota 57701-2712
(605) 343-6102

BBC Research & Consulting
1999 Broadway, Suite 2200
Denver, Colorado 80202
(303) 321-2547

FHU Reference No. 113-039-01
September 2014

The preparation of this report has been financed in part through grant[s] from the Federal Highway Administration and Federal Transit Administration, U.S. Department of Transportation, under the State Planning and Research Program, Section 505 of Title 23, U.S. Code. The contents of this report do not necessarily reflect the official views or policy of the U.S. Department of Transportation.

The South Dakota Department of Transportation provides services without regard to race, color, gender, religion, national origin, age or disability, according to the provisions contained in SDCL 20-13, Title VI of the Civil Rights Act of 1964, the Rehabilitation Act of 1973, as amended, the Americans With Disabilities Act of 1990 and Executive Order 12898, Federal Actions to Address Environmental Justice in Minority Populations, 1994. To request additional information on the SDDOT's Title VI/Nondiscrimination policy or to file a discrimination complaint, please contact the Department's Civil Rights Office at 605-773-3540.



TABLE OF CONTENTS

	<u>Page</u>
I. INTRODUCTION	1
A. Study Background.....	1
B. Study Purpose and Objectives.....	1
C. Study Process.....	2
D. Study Rest Areas.....	4
II. EXISTING CONDITIONS	6
A. Data Collection.....	6
B. Rest Area Facility Conditions.....	14
C. Parking Conditions	16
III. FUTURE USE FORECASTS	19
A. Parking Forecasts.....	19
B. Rest Area Visitor Forecasts.....	21
IV. FUTURE NEEDS	23
A. Valley Springs.....	24
B. Valley Springs Port of Entry	25
C. Homestead.....	26
D. Hidewood Northbound	27
E. Hidewood Southbound.....	28
F. Tilford Eastbound.....	29
G. Tilford Westbound.....	30
H. Preservation Cost Estimates	31
V. BENEFIT COST AND PRIORITIZATION	32
A. Strategic Facilities Management Approach.....	32
B. Rest Area Study Process.....	34
C. Repair Plan Calculations	35
D. Results	36
E. Cost-Benefit Prioritization	37
F. Other Priority Considerations.....	38
G. Final Recommendations.....	38
VI. SUMMARY OF FINDINGS AND RECOMMENDATIONS	40

List of Appendices

- Appendix A. Methods and Assumptions Document for the Rest Areas Study
- Appendix B. Facility Assessment
- Appendix C. Parking Analysis
- Appendix D. Needs Assessment
- Appendix E. Prioritization and Financial Analysis



LIST OF FIGURES

	<u>Page</u>
Figure 1. Study Work Flow -----	2
Figure 2. Rest Areas Studied -----	5
Figure 3. Valley Springs Rest Area Site Layout-----	7
Figure 4. Valley Springs Port of Entry Site Layout-----	8
Figure 5. Homestead Rest Area Site Layout-----	9
Figure 6. Hidewood Northbound Rest Area Site Layout -----	10
Figure 7. Hidewood Southbound Rest Area Site Layout-----	11
Figure 8. Tilford Eastbound Rest Area Site Layout-----	12
Figure 9. Tilford Westbound Rest Area Site Layout-----	13
Figure 10. Current Truck Parking Spaces and Demand -----	17
Figure 11. Current Passenger Vehicle Parking Spaces and Demand -----	18
Figure 12. Forecast 2040 Truck Parking Spaces and Demand-----	20
Figure 13. Forecast 2040 Passenger Vehicle Parking Spaces and Demand -----	21
Figure 14. Hierarchy of Parts -----	33
Figure 15. Present Value of Repair Plans – Hidewood North -----	37

LIST OF TABLES

Table 1. Rest Area Deficiencies-----	15
Table 2. Current Rest Area Parking Capacity -----	16
Table 3. Parking Growth Rates and Factors -----	19
Table 4. Additional Truck Parking Needs -----	20
Table 5. Daily Visitor Summary-----	22
Table 6. 2040 Restroom and Lagoon Expansion Needs by Rest Area -----	22
Table 7. Cost of Preservation by Rest Area-----	31
Table 8. Assumptions for Facility Reinvestment Model -----	35
Table 9. Preservation Investment per Visitor Hour -----	37
Table 10. New Facility Investment per Visitor Hour-----	38



I. INTRODUCTION

A. *Study Background*

Much is being asked of the 20 Interstate rest areas and 4 ports of entry (POEs) along Interstate highways in South Dakota. Constantly in service, these havens provide safe places to nap, picnic, and play. They offer traveler information, bathroom facilities, snack vending, tourism services, overnight truck parking, and more. The South Dakota Department of Transportation (SDDOT) devotes significant time and resources to its rest areas through routine maintenance and regular investments in enhancements to services and infrastructure.

Though the network of Interstate rest areas is a tremendous asset to South Dakota residents and visitors, the system is under pressure. Many rest area parking lots strain under increasing truck parking demand as drivers require sleep and truck freight traffic continues to trend upward. Most rest areas possess infrastructure first built in the 1970s, which requires maintenance and upgrades to continue to serve the traveling public. Some rest area pedestrian pathways, buildings, and restroom facilities need upgrades to conform to the Americans with Disabilities Act (ADA) and provide accessibility for all visitors.

To direct investments in the system, SDDOT has undertaken the Interstate Rest Areas Study: Along the I-29 and I-90 Corridors (Rest Areas Study), a comprehensive analysis of seven rest areas along Interstates 90 and 29 in South Dakota.

B. *Study Purpose and Objectives*

The purpose of the study is to assess rest area conditions, provide a plan for preserving the ability of these rest areas to continue to meet demand, and determine when to stop investing funds into preservation and channel monies toward constructing a new facility.

The objectives of this project are to:

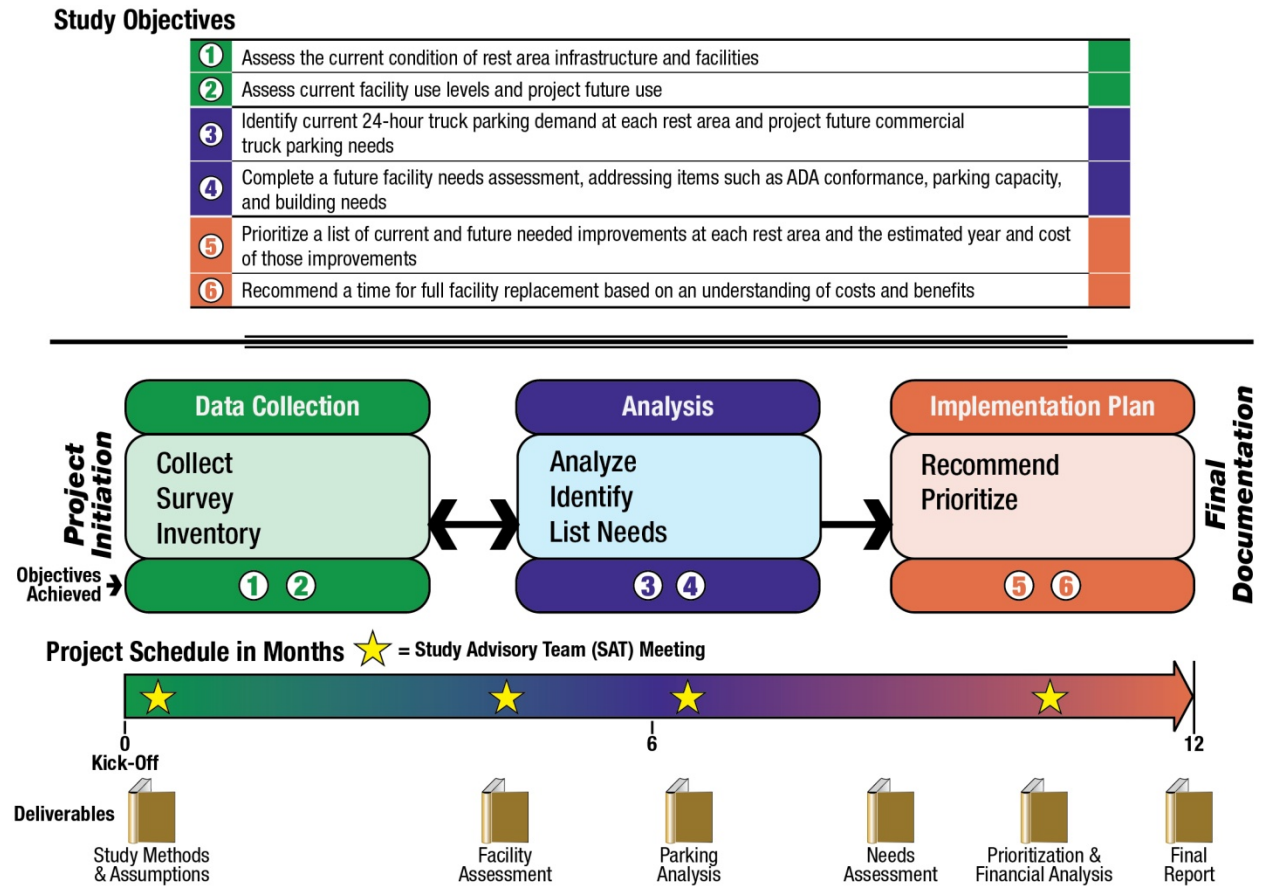
1. Assess the current condition of rest area infrastructure and facilities
2. Assess current facility use levels and project future use
3. Identify current 24-hour truck parking demand at each rest area and project future commercial truck parking needs
4. Complete a future facility needs assessment, addressing items such as ADA conformance, parking capacity, and building needs
5. Prioritize a list of current and future needed improvements at each rest area and the estimated year and cost of those improvements
6. Recommend a time for full facility replacement based on an understanding of costs and benefits

C. Study Process

Work Flow and Schedule

The project team designed a work flow and a schedule to meet the six study objectives, and the result is depicted on **Figure 1**. The project began in summer 2013 with the development of the Methods and Assumptions Document. Data collection efforts included site visits, interviews with SDDOT maintenance staff, and traffic/parking data collection at each rest area. The gathered data were used to develop an analysis of needs. Improvements were identified and prioritized in the Implementation Plan stage. Four meetings with the Study Advisory Team were used to support each step and to ensure that objectives were met.

Figure 1. Study Work Flow



Six project deliverables depicted on **Figure 1** support the project objectives. They are described as follows:

Study Methods and Assumptions – The Federal Highway Administration (FHWA) requires the Methods and Assumptions Document for all planning projects. The document, which was approved by FHWA and SDDOT staff, includes basic study information (study area, schedule, etc.) and the parameters to be used to govern the study’s analytical components. Such parameters include analysis time periods, seasonal factors, forecasting methodology, data collection plan, and measures of effectiveness to be used. **Appendix A** contains the approved Methods and Assumptions Document for the Rest Areas Study.



Facility Assessment – A detailed facility assessment was completed for each rest area. Each assessment describes the facility design, operations, and building systems, including items such as sidewalks, parking areas, lighting, signage, landscaping, restroom capacity, utilities, picnic shelters, building shell and structure, mechanical and plumbing systems, electrical, interior finishes, and communications/IT equipment.

Upon describing these characteristics, the assessment provides an evaluation of rest area conditions using:

- Site visit and visual check
- Interview with maintenance personnel
- Code conformity review
- ADA compliance survey

Per the request of SDDOT staff, the assessment information was compiled into Auditmate format and the complete ADA Checklist for Readily Achievable Barrier Removal.

Appendix B presents the Facility Assessment.

Parking Analysis – The parking analysis provided, for each rest area, a count of current parking spaces for trucks and passenger vehicles, a 24-hour profile of current parking demand for both passenger vehicles and trucks, and forecasted growth in parking occupancy to the Year 2040. The analysis identified rest areas where additional spaces would be needed to meet demand and provided a preliminary layout for future parking expansion.

Appendix C contains the Parking Analysis.

Needs Assessment – The Needs Assessments for each rest area provide a synopsis of improvements needed to keep the rest area functioning to the Year 2040. The parking demand forecasts included in the Parking Analysis are used to develop future user forecasts, which translate to loading for the restrooms and other site infrastructure. Condition information from the Facility Assessments is used to determine the nature and timing of improvements, which are placed into 5-year increments from the Year 2020 through 2040 based on urgency of need. The Needs Assessment provides conceptual cost information for all improvements.

Appendix D provides the Needs Assessment.

Prioritization and Financial Analysis – This deliverable applies a financial view to the needs and improvements identified in the Needs Assessment, resulting in a series of recommendations to SDDOT regarding how to channel resources toward maintenance and replacement. The analysis offers a series of recommendations about timing of facility replacement.

Appendix E includes the Prioritization and Financial Analysis.

Final Report – The Final Report summarizes the key conclusions and recommendations from the project deliverables and provides a document SDDOT can use as a reference moving forward. All of the project deliverables are referenced in the Final Report and included as appendices.



Project Governance

The project Study Advisory Team (SAT) was formed before the project kickoff in June 2013. The SAT consists of consultant staff and SDDOT staff from a variety of departments, including Project Development, Research, Road Design, Administration, and Traffic Engineering. A representative of FHWA was also included on the SAT. Each SDDOT region containing at least one of the rest area locations (Aberdeen, Mitchell, and Rapid City) was also represented on the SAT.

D. Study Rest Areas

The study addresses infrastructure and parking needs at each of seven locations and identifies actions needed to preserve rest area functionality into the future. These seven include a portion of the 24 total rest areas and POEs along Interstates in South Dakota. These locations were identified for study due to known needs or issues related to aging or deficient site infrastructure and/or heavy demand for parking.

The rest areas studied include:

1. Valley Springs Westbound I-90
2. Valley Springs Port of Entry (POE) Westbound I-90
3. Homestead Northbound/Southbound I-29
4. Hidewood Northbound I-29
5. Hidewood Southbound I-29
6. Tilford Eastbound I-90
7. Tilford Westbound I-90

Figure 2 provides a layout of rest areas in relation to the state boundary.

- 1 Valley Springs Westbound I-90
- 2 Valley Springs Port-of-Entry Westbound I-90
- 3 Homestead Northbound / Southbound I-29
- 4 Hidewood Northbound I-29
- 5 Hidewood Southbound I-29
- 6 Tilford Eastbound I-90
- 7 Tilford Westbound I-90



LEGEND

- X Studied Rest Areas
- ◆ Private Truck Stop Locations
- ▲ Other Rest Areas / Ports of Entry

Figure 2. Studied Rest Areas



II. EXISTING CONDITIONS

A. *Data Collection*

The data collection effort consisted of the following activities:

Facility Assessments – Facility assessments were completed in the fall of 2013. On-site visual reviews and meetings were held with responsible SDDOT maintenance staff, after which a thorough review of the existing infrastructure was completed to determine the condition of various infrastructure components. After this review, a second field visit was made to each rest area to complete an ADA assessment and survey. The project team completed AuditMate-compatible data sheets and ADA checklists for each rest area.

Figures 3 through 9 provide aerial depictions of each rest area and identify basic rest area characteristics.

Parking Demand – Video cameras posted at each rest area were used to gather parking data. The number of trucks and passenger vehicles was recorded at 5-minute intervals to create a profile of current parking demand at each rest area.

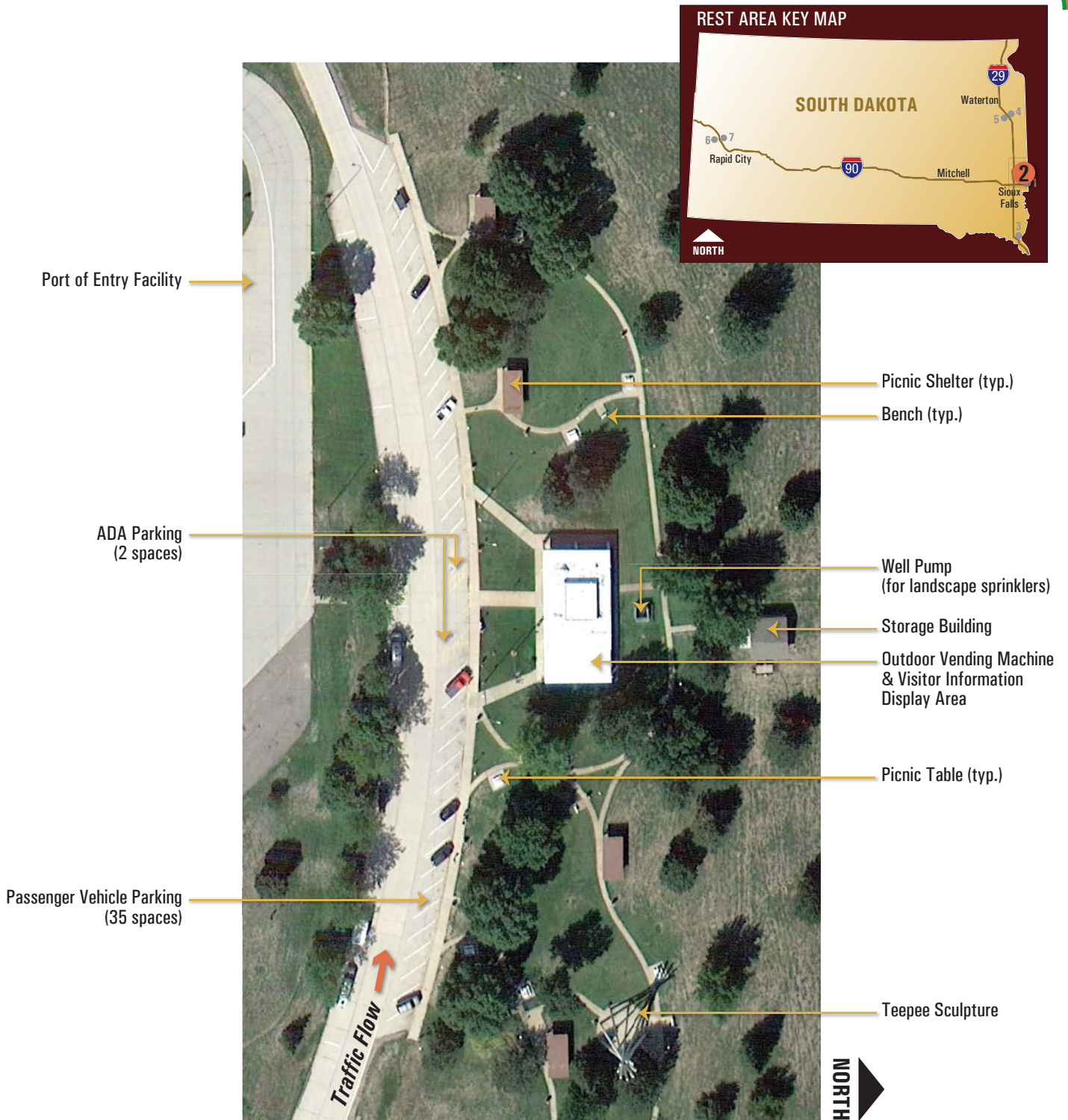


Figure 3. Valley Springs Rest Area Site Layout



Figure 4. Valley Springs Port of Entry Site Layout



Figure 5. Homestead Rest Area Site Layout

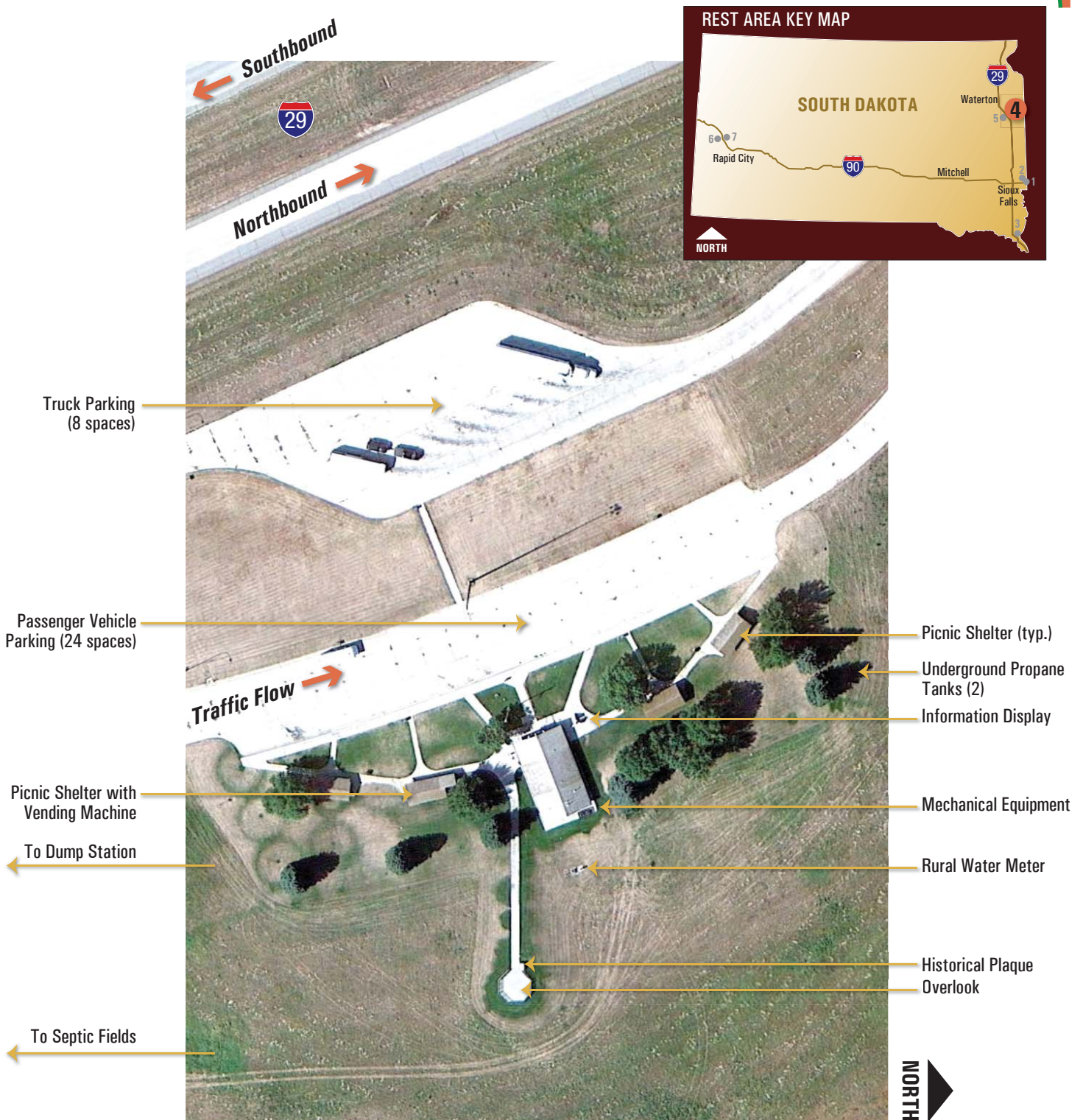


Figure 6. Hidewood Northbound Rest Area Site Layout

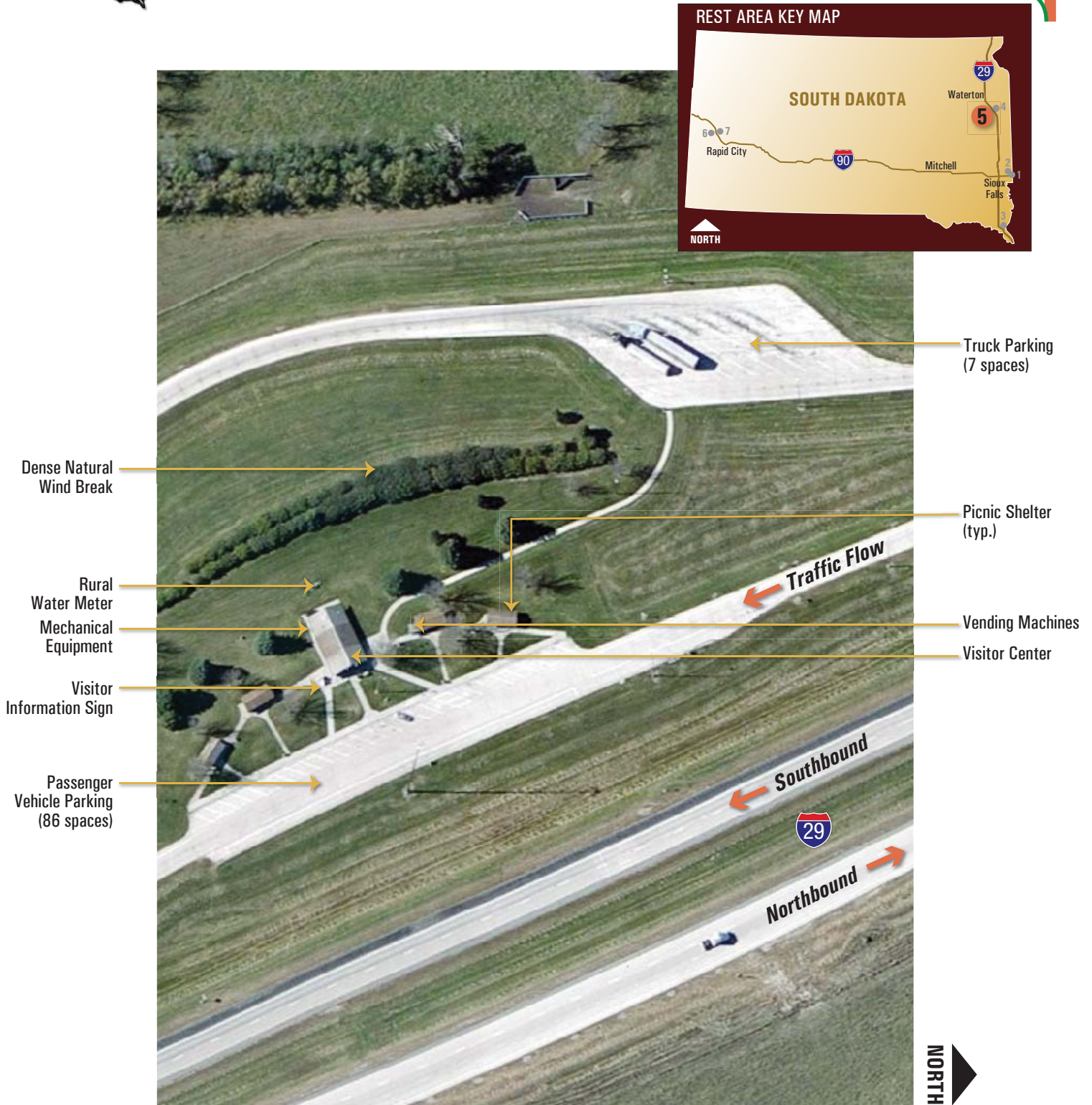


Figure 7. Hidewood Southbound Rest Area Site Layout

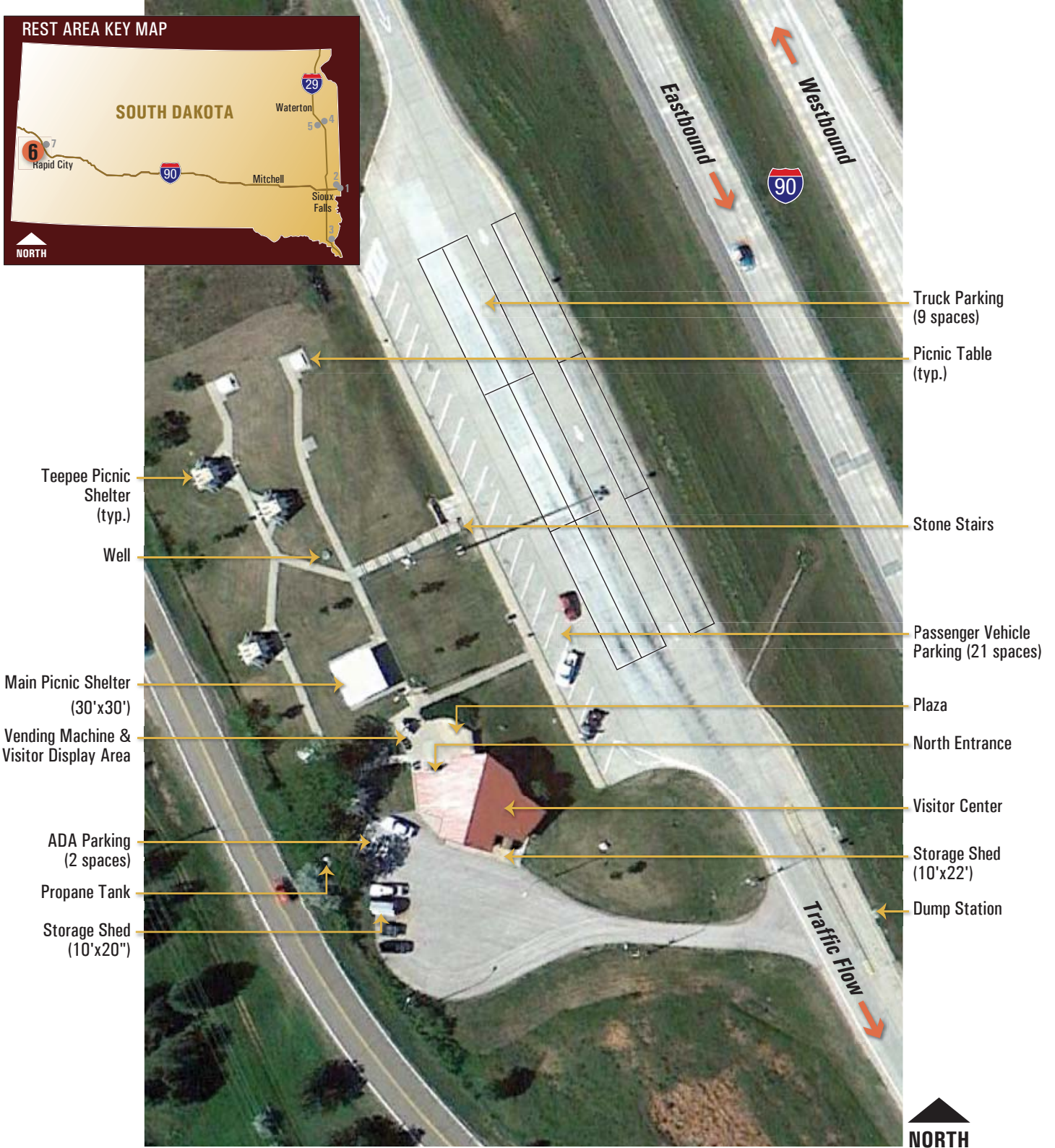


Figure 8. Tilford Eastbound Rest Area Site Layout



Figure 9. Tilford Westbound Rest Area Site Layout

B. Rest Area Facility Conditions

SDDOT requested that a comprehensive assessment be performed to sharpen awareness of issues that may be hindering the function of the rest areas. In response, the project team conducted a detailed inventory and conditions assessment of each rest area. Elements captured in the assessment included the following:

- Basic rest area amenities: vending, information, artwork
- Structures
- Landscape amenities such as benches and shelters
- Utilities: water, wastewater, electric, telephone, gas
- Building systems: architectural, plumbing, mechanical, electrical
- Site infrastructure: parking areas, sidewalks, paths
- Paved areas
- Restrooms: access, stalls, lavatories, toilets, sinks, signage
- Building Code conformity
- Accessibility per ADA requirements

Table 1 describes the deficiencies found to be unique to each rest area and held in common among the rest areas. This information was compiled from the Facility Assessments in **Appendix B**. Deficiencies included non-compliant electrical outlets, lack of a family restroom, aging components, pavement deficiencies, cramped restroom and lobby spaces, and deteriorating or non-functional heating, ventilation, and air conditioning systems. As shown, all of the rest areas possess ADA deficiencies, having been constructed before the legislation was passed in 1990. Identified ADA deficiencies included door closing rates, counter heights, toilet placement, and public telephone location.

In summary, these deficiencies indicate that various investments need to be made in repair and rehabilitation, ADA upgrades, and Code compliance efforts for the rest areas to continue to function in an acceptable fashion.

Table 1. Rest Area Deficiencies

Rest Area	Location	Year Built	Deficiencies	Deficiencies in Common
Valley Springs	I-90 Westbound MRM 412	1973	<ul style="list-style-type: none"> Does not meet current Building Code for outlets, lacks a ventilation system, has storage areas that do not meet minimum clearance Leaking sanitary lagoons Many components beyond, at, or near the limit of service life Inadequate air conditioning unit Deteriorating heater 	<ul style="list-style-type: none"> Facility does not meet ADA standards for many components, including accessible parking spaces, signage, pathway slopes, information displays, door handle clearance, door width, door closure time, picnic bench dimensions, restroom counter heights and stall and fixture dimensions, public telephone location/provision Some pavement deficiencies No family restroom
Valley Springs POE	I-90 Westbound MRM 412	1984	<ul style="list-style-type: none"> Insufficient space in building for POE functions Confusion results from shared POE/public rest area access Scale system can freeze in wintry conditions Undesirable outdoor inspection area Need for more electrical outlets per Building Code Ceiling exhaust fans do not meet Code Inadequate heating and cooling systems for occupants Leaking sanitary lagoons Many components beyond, at, or near the limit of service life 	
Homestead	NB/SB I-29 MRM 26	1977	<ul style="list-style-type: none"> Trash demand exceeding capacity Inoperable exhaust ventilation for basement equipment room Occasional clogging of lagoons Exit ramp to SD 50 can be slippery during wintry conditions 	
Hidewood Northbound	NB I-29 MRM 160	1980	<ul style="list-style-type: none"> Noticeably small restrooms Cedar roofs in poor condition Some components are beyond, at, or near the limit of service life 	
Hidewood Southbound	SB I-29 MRM 160	1980	<ul style="list-style-type: none"> Cedar structure roofs in poor condition Small and narrow restrooms Truckers forced into a lengthy walk to the building 	

Rest Area	Location	Year Built	Deficiencies	Deficiencies in Common
Tilford Eastbound	EB I-90 MRM 41	1973	<ul style="list-style-type: none"> Does not meet current Building Code for outlets, lacks a ventilation system, has storage areas that do not meet minimum clearance Inadequate storage space for tourist information center Unpleasant odors emanating from rest area open lagoons Difficult pedestrian access up 10-15' to the building from the parking lot 	<ul style="list-style-type: none"> Facility does not meet ADA standards for many components, including accessible parking spaces, signage, pathway slopes, information displays, door handle clearance, door width, door closure time, picnic bench dimensions, restroom counter heights and stall and fixture dimensions, public telephone location/provision Some pavement deficiencies No family restroom
Tilford Westbound	WB I-90 MRM 41	1973	<ul style="list-style-type: none"> Does not meet current Building Code for outlets, lacks ventilation system, storage areas do not meet minimum clearance Inadequate storage space for tourist information center Building not winterized or insulated Difficult pedestrian access down 5' to the building from the parking lot Unpleasant odors emanating from rest area open lagoons Water piping insulation in poor condition Furnace and AC unit in need of replacement 	

C. Parking Conditions

Parking capacity is a precious resource at the Interstate rest areas. The seven rest areas provide a total of 67 truck parking spaces and 166 passenger vehicle spaces, for an average of 10 truck and 24 passenger vehicle spaces. **Table 2** summarizes the available parking capacity at each rest area.

Table 2. Current Rest Area Parking Capacity

Rest Area	Truck Parking Spaces	Passenger Vehicle Spaces
Valley Springs	0	37
Valley Springs POE	7	4 (POE staff)
Homestead	27	33
Hidewood Northbound	8	24
Hidewood Southbound	7	26
Tilford Eastbound	9	21
Tilford Westbound	9	21

To gain an understanding of how this capacity is currently being used, the project team conducted 24-hour parking occupancy counts at each rest area during the week of September 16 through September 20, 2013. Video cameras were used to capture parking conditions for a 24-hour block of time in both the passenger vehicle and truck parking areas. Trucks are defined as semi-truck and trailer, while passenger vehicles represent all other vehicle types.

After compiling the parking data at each rest area, several factors were analyzed to quantify how the parking lots operate during the study period.

Total Parked Vehicles – Over the full 24-hour period, the results show that the Valley Springs Westbound Rest Area serves the most passenger vehicles during the study period. The two Hidewood Rest Areas accommodate a similar number of parked trucks during the 24-hour period, which exceeds truck visits at the other facilities.

Parking Duration – The average duration of both passenger vehicles and trucks over the 24-hour collection period was calculated. In general, passenger vehicles are parked at rest areas for less time than trucks. The time vehicles are parked increases during the nighttime hours, especially for trucks. The duration of truck parking during the nighttime increases to between 2 to 15 times that of daytime operations.

Parking Occupancy – The average number of occupied spaces (parking occupancy) for both passenger vehicles and trucks at each facility was analyzed to determine the adequacy of the existing parking facilities.

Figure 10 depicts the truck parking spaces and demand. As shown, truck parking capacity meets average and maximum demand at each rest area, though the maximum number recorded at both Hidewood Rest Areas nearly reaches the capacity.

Figure 10. Current Truck Parking Spaces and Demand

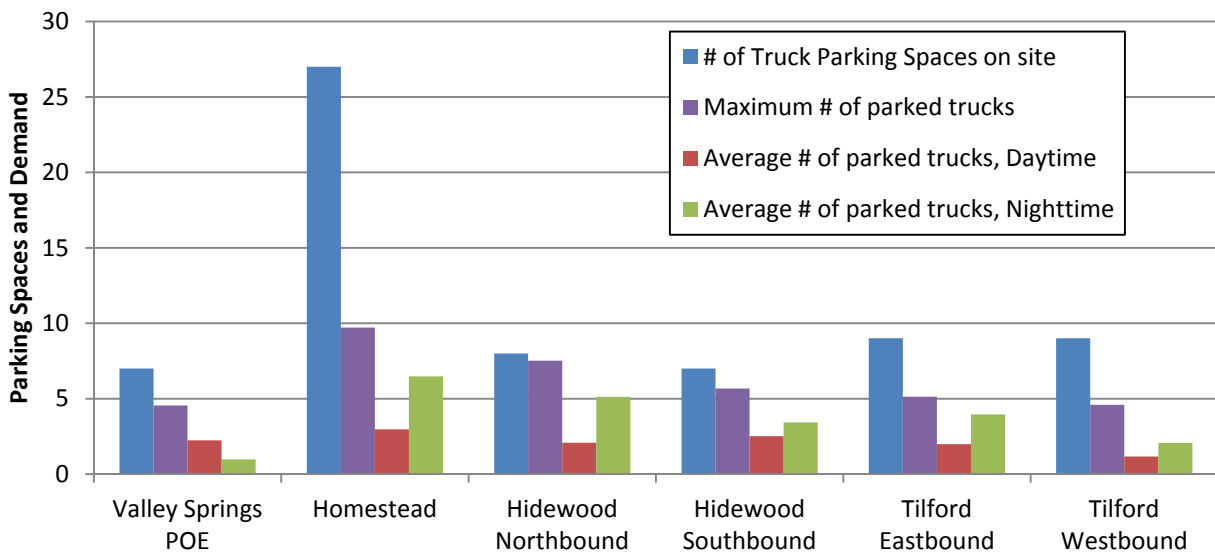
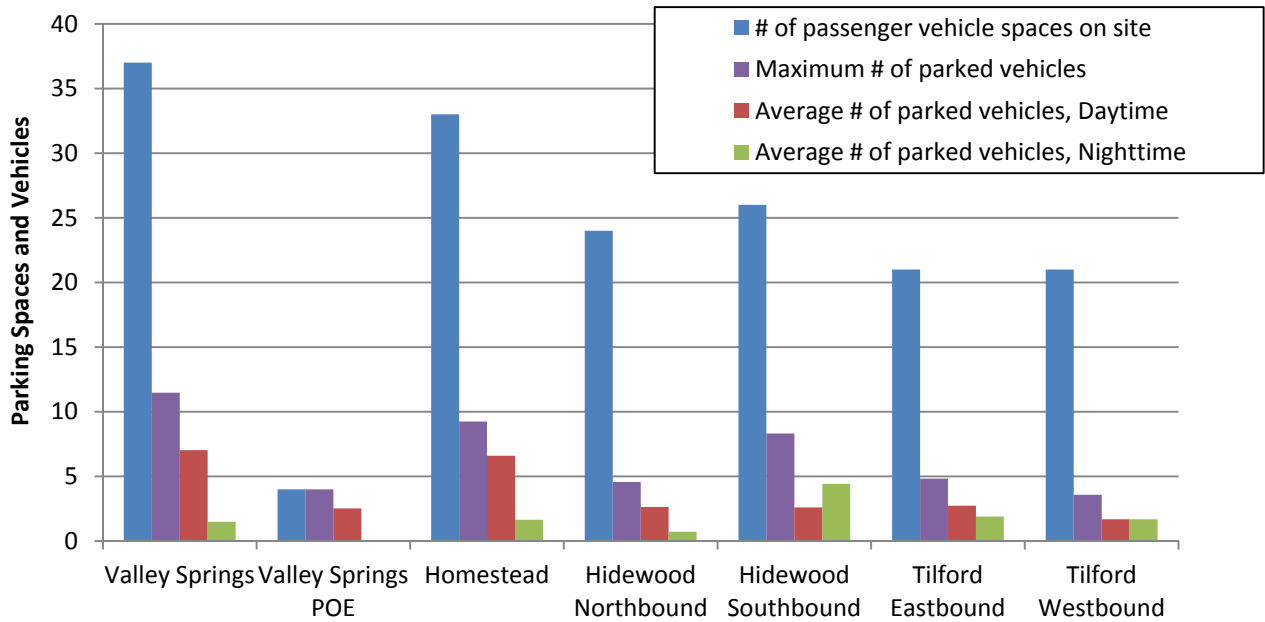


Figure 11 depicts the passenger vehicle parking spaces and occupancy. As shown, passenger vehicle parking capacity easily meets average and maximum demand at each rest area.

Figure 11. Current Passenger Vehicle Parking Spaces and Demand



As stated previously, parking at some rest areas was shown to operate at or near the capacity threshold during portions of the day. In addition, parking conditions at each facility vary throughout the day and experience unique trends. The Parking Analysis in **Appendix C** describes these trends in detail.

III. FUTURE USE FORECASTS

The potential for future increase in rest area demand must be considered to adequately evaluate the need for improvements. Anticipated future increase in interstate traffic flows, both passenger vehicles and trucks, will place additional strain on parking supply. Additional visitors will stretch the capabilities of restrooms, lobbies, walkways, utilities, and site amenities. The project team developed future use forecasts to account for these impacts.

A. Parking Forecasts

Two separate actions were taken to forecast future parking demand:

1. The truck and passenger vehicle parking counts were adjusted to reflect seasonal increases in traffic experienced in South Dakota.

Parking conditions at rest areas throughout South Dakota can fluctuate based on the time of year (higher in the summer, lower in the winter) due to tourist-related traffic and the weather. To account for these changes in travel patterns during a typical year, September 2013 parking counts at each rest area were adjusted to reflect peak conditions. Historical traffic counts at rest area automated traffic records (ATRs) or the mainline counts nearest the facility were used to adjust the existing parking counts to peak conditions. Seasonal adjustment factors varied from 1.1 to 1.6, with the greatest difference at the Tilford Rest Areas adjacent to the tourist-heavy Black Hills.

2. The seasonally adjusted conditions were projected to the future planning year, 2040.

Different methodologies were used for projecting passenger vehicle and truck traffic parking. For the passenger parking estimates, the *Highway Needs and Project Analysis Report* (SDDOT, 2013) and the *South Dakota Decennial Interstate Corridor Study* (Felsburg Holt & Ullevig, 2010) were consulted. Growth rates in interstate traffic were used to estimate passenger parking demand at each facility. Information from the FHWA Freight Analysis Framework (FAF) was used to develop long-term truck parking estimates at each rest area. The FAF includes long-term truck volume projections for each section of interstate and key state highways throughout the nation. These truck traffic projections were used to develop the long-term truck parking estimates at each rest area.

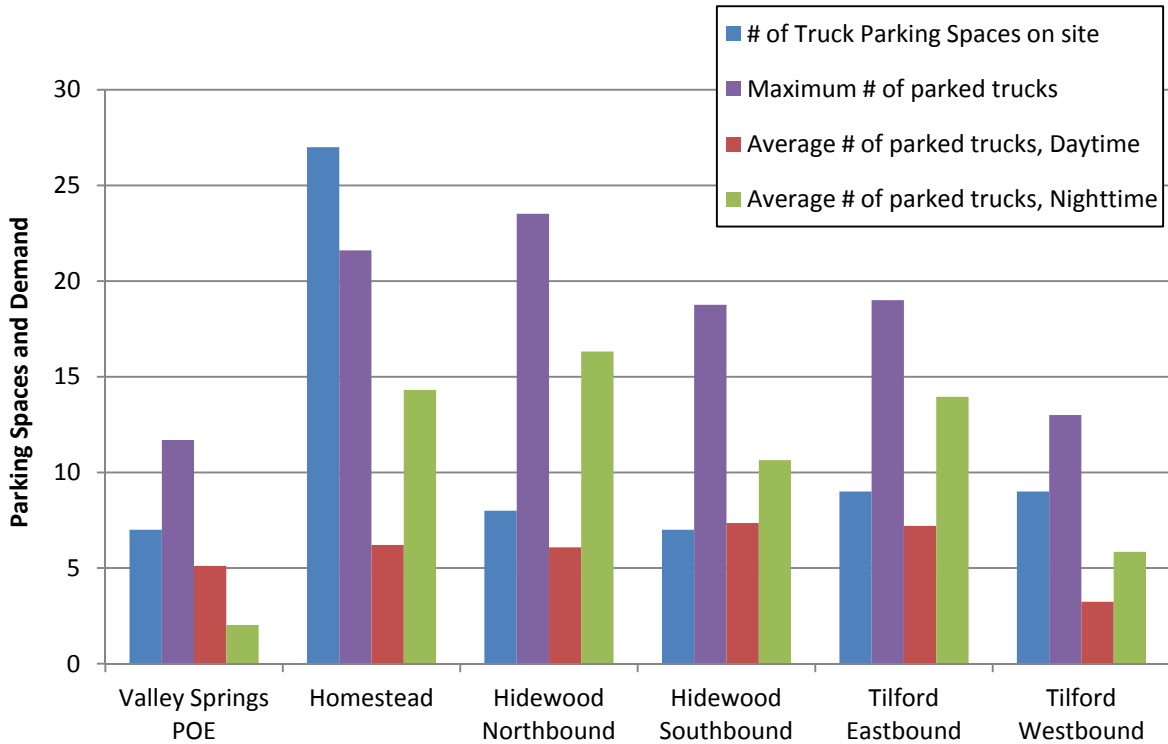
Table 3 summarizes the results.

Table 3. Parking Growth Rates and Factors

Rest Area	Annual Growth Rate (2013–2040 Factor)	
	Trucks	Passenger Vehicles
Valley Springs Westbound & POE	2.96% (2.2)	2.16% (1.78)
Homestead	2.64% (2.0)	1.38% (1.45)
Hidewood Northbound	3.87% (2.8)	1.32% (1.42)
Hidewood Southbound	3.87% (2.8)	1.32% (1.42)
Tilford Eastbound	3.08% (2.2)	0.89% (1.27)
Tilford Westbound	3.08% (2.2)	0.89% (1.27)

The growth factors were applied to the existing parking occupancy count results to determine long-term parking demand and to identify locations where expansion would be needed. **Figure 12** depicts the truck parking spaces and demand.

Figure 12. Forecast 2040 Truck Parking Spaces and Demand



As shown, truck parking capacity is exceeded by maximum demand at all locations but Homestead. **Table 4** lists the additional needed spaces.

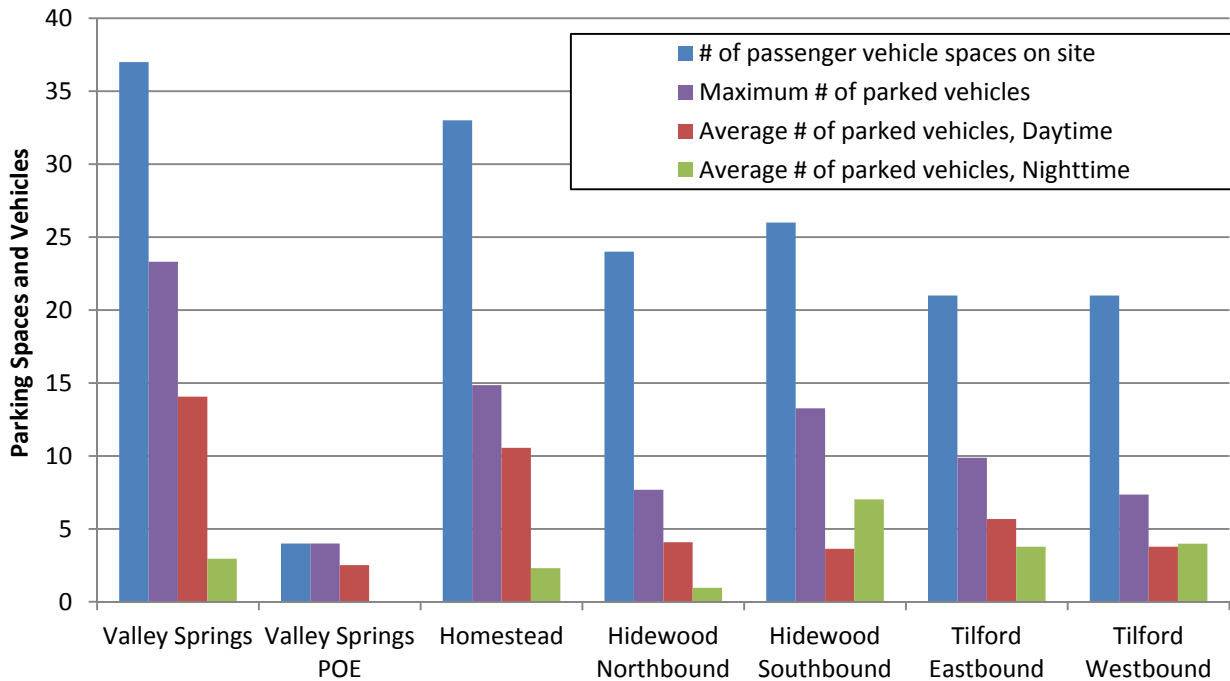
Table 4. Additional Truck Parking Needs

Rest Area	Number of Truck Parking Spaces		
	Current	Additional Needed	Total Needed
Valley Springs POE ¹	7	5	12
Hidewood Northbound	8	16	24
Hidewood Southbound	7	12	19
Tilford Eastbound	9	10	19
Tilford Westbound	9	4	13

¹Based on discussions with SDDOT, in the future POEs throughout the State may be equipped with electronic pass capabilities, resulting in up to 60 percent of all truck traffic bypassing POEs. Therefore, a second 2040 projection was added assuming electronic metering is installed at the POE. Based on the expected 60 percent reduction in truck traffic requiring inspection, the existing POE would be able to handle the projected parking demand through year 2040.

Figure 13 shows the passenger vehicle parking spaces and occupancy. As shown, passenger vehicle parking capacity by 2040 continues to meet average and maximum demand at each rest area.

Figure 13. Forecast 2040 Passenger Vehicle Parking Spaces and Demand



B. Rest Area Visitor Forecasts

The project team used the current and forecasted parking demand as a basis for current and future user demand, which was used to assess the ability of rest area buildings and site infrastructure to accommodate visitor growth. Several assumptions were made to translate vehicles parked into visitor totals, described as follows:

Vehicle Occupancy – In the memorandum *1992 Safety Rest Area Usage Survey Reports* (Minnesota Department of Transportation, 1992), a user survey of motorists at the Marion Rest Area in Minnesota identified an average of 2.3 persons per vehicle. This average was used as an estimate for the occupants per passenger vehicle. In addition, it was assumed that the number of male and female occupants per vehicle would be equal.

Truck Occupancy – Truck occupancy is anticipated to be fewer than passenger vehicles, as most trucks have only a single driver. For purposes of this analysis, a 1.5 persons per vehicle occupancy rate was used for truck parking, which accounts for the presence of tandem truck drivers. Currently, around 93 percent of truck drivers are male, but the number of female drivers is expected to increase in the future (<http://gobytrucknews.com/female-truckers-growing-in-number/>). To remain conservative, an 80/20 mix of male to female users was applied to the truck parking to account for an increase in female truck drivers.



Using these assumptions, the number of parked trucks and vehicles per peak season day was translated into visitor numbers for each rest area. **Table 5** summarizes the results.

Table 5. Daily Visitor Summary

Rest Area	Current Visitors Per Day			2040 Visitors Per Day		
	Trucks	Passenger Vehicles	Total	Trucks	Passenger Vehicles	Total
Valley Springs ¹	84	812	896	185	1,436	1,621
Homestead	90	266	356	182	388	570
Hidewood Northbound	136	504	640	384	715	1,099
Hidewood Southbound	153	430	583	429	612	1,041
Tilford Eastbound	123	294	417	270	375	645
Tilford Westbound	108	239	347	260	304	564

¹Includes visitors from trucks parked at adjacent Valley Springs Port of Entry

Peak period use of the facilities was derived from hourly parking occupancy rates contained in the Parking Analysis. Peak use was compared with the available number of stalls in the men’s and women’s restrooms at each rest area, and expansion needs were noted where capacity would not be sufficient to meet Year 2040 demand. All restrooms and lagoons were found to be sufficient to meet current visitor demand, and capacity in the women’s restrooms is adequate to the Year 2040. However, some men’s restrooms would need expansion by the Year 2040 to meet increased demand. The restrooms at the Hidewood Rest Areas would need two to three additional stalls and one additional stall at the Tilford Rest Areas. **Table 6** summarizes the restroom expansion and lagoon capacity needs by rest area.

Table 6. 2040 Restroom and Lagoon Expansion Needs by Rest Area

Rest Area	Men’s	Women’s	Lagoon Capacity
Valley Springs ¹	OK	OK	Adequate to 2040
Homestead	OK	OK	Adequate to 2030
Hidewood Northbound	2 additional stalls ²	OK	Adequate to 2030
Hidewood Southbound	3 additional stalls ²	OK	Adequate to 2030
Tilford Eastbound	1 additional stall ²	OK	Adequate to 2040
Tilford Westbound	1 additional stall ²	OK	Adequate to 2040

¹Includes visitors from trucks parked at adjacent Valley Springs Port of Entry
²Assumes loss of one existing stall to ADA consolidation

IV. FUTURE NEEDS

In its Long Range Transportation Plan, SDDOT has articulated its goal to “Preserve and maintain South Dakota’s transportation system.” Consistent with this objective, the project team developed recommendations with a focus on rest area preservation rather than expansion and enhancement. Expansion and enhancement may be accomplished by reconstructing a rest area when it has reached breakdown in basic preservation functions and cannot be cost-effectively repaired.

The Parking Analysis, Site Assessments, and forecasts were used to develop a picture of future needs at each rest area, resulting in a list of the minimum investments needed over the next 25 years to:

- Provide Code conformity
- Achieve ADA compliance
- Provide adequate parking space for trucks and passenger vehicles
- Provide sufficient restroom capacity for visitors
- Preserve building system functionality, including
 - Plumbing
 - Mechanical
 - Electrical
- Preserve acceptable site conditions, including
 - Pavement
 - Structures (including out-buildings, picnic shelters, and sculptural elements)
 - Lagoons
 - Lighting
- Provide routine maintenance and upkeep

The project team developed a plan for accomplishing these items, grouping investments into 5-year increments based on the level of urgency to maintaining rest area function. This includes an assessment of when the facility should be fully reconstructed due to the inability of any rest area to continue to meet minimum functionality without costly repairs.

The findings are described as follows by future horizon year, as a preservation plan for each rest area through the Year 2040. The items described are detailed and expanded upon in the detailed Needs Assessments provided in **Appendix D**.

A. Valley Springs

A significant amount of work on the Valley Springs Rest Area is necessary in the near future to bring the facility into code and ADA compliance and provide minimum functionality. Upon completion of this renovation, the rest area will require routine maintenance and some pavement work until full reconstruction is needed.

The following sections generally describe improvements to the facility in 5-year increments starting in year 2020 through year 2040:

Year 2020: The facility was constructed in 1973 and is in need of a significant renovation to provide ADA upgrades and to refurbish the aged infrastructure. It is recommended that this work be accomplished by the Year 2020. With this renovation, the service life of the facility can be extended to 2040 when it will be nearing capacity and ready for replacement. The following summarize the 2020 horizon improvements:

- Code Improvements (IBC 2012): Provide GFI outlets, new mechanical system, standard storage areas, and accessible drinking fountain
- ADA Improvements: Address parking lot grade issues, picnic seating, narrow doors, counter heights, restroom interior clearances, accessible restroom stalls, heights of dispensers, etc.
- Site Systems: Regular lagoon upgrade, replace irrigation system, repair pavement deficiencies, replace lighting fixtures, inspect structures, and refurbish picnic shelters
- Main Building and Building Systems: Renovate main building with exterior and interior upgrades to walls, windows, doors, roofing, and cabinetry. Upgrade storage garage
 - Plumbing System: Replace aging components, including water heater, piping, lavatory sinks
 - Mechanical System: Provide new mechanical system for main building to comply with Code
 - Electrical System: Replace circuit breaker panels, replace electric hand dryers, and upgrade CCTV system for remote monitoring

Year 2025: Major improvements are not anticipated from year 2020 through year 2025. Annual maintenance allows the facility to meet demand through the 5-year horizon.

Year 2030: Provide additional concrete pavement panel replacement (10 percent). Replace 20 percent of the sidewalks. Replace all asphalt shoulders.

Year 2035: Major improvements are not anticipated from year 2030 through year 2035. Annual maintenance allows the facility to meet demand through the 5-year horizon.

Year 2040: At this time, the facility will have reached the service life limits for both the facility and the site infrastructure. The facility will also reach capacity and require an expansion as well as for parking. Given the extent of the projected renovation, plus the costs of the addition, a new expanded 40-year replacement facility will be of better value at this time extending the useful life goal to 2080.

B. Valley Springs Port of Entry

The POE is unique among the seven rest areas studied because it performs an administrative function and does not serve the general public as a rest area. SDDOT is seeking to reconstruct the Valley Springs POE to enhance its administrative function by providing a similar facility to the newly reconstructed POE recently completed near Sisseton, South Dakota, along southbound I-29. The existing POE is too small to meet current and future needs, does not provide an electronic pass system, and needs an enclosed inspection station.

The project team assessed the ability of the current site to accommodate an updated POE, and found that while it is physically feasible to expand and update the POE on the current site, an upgraded POE would still need to share vehicular access with the adjacent rest area, and sanitary service may require pumping. For these reasons, consideration should also be given to finding an alternative facility location for the upgraded POE.

Though it is anticipated that the facility will be reconstructed, the project team completed a preservation plan to provide POE services should the reconstruction project be delayed or deemed infeasible.

The following sections generally describe improvements to the facility in 5-year increments starting in year 2020 through year 2040:

Year 2020: The facility infrastructure has been so heavily used it is essentially ready for a total renovation, plus an addition. The following list of deficiencies will need to be addressed to restore the facility to long-term viability:

- Code Improvements (IBC 2012): Provide GFI outlets, new HVAC system, standard storage areas, and dual water cooler drinking fountain
- ADA Improvements: Designate accessible parking space and upgrade ramp, doors, restrooms, and counters
- Site Systems: Repair deteriorating pavement and replace outdoor lighting fixtures
- Main Building and Building Systems: Renovate building with exterior and interior upgrades to walls, windows, doors, roofing, and cabinetry
 - Plumbing System: Replace aging components, including water heater and piping insulation
 - Mechanical System: Replace restroom fan and provide a new HVAC system
 - Electrical System: Replace interior lighting fixtures, circuit breaker panel, and CCTV system; and provide closed circuit alarm with central monitoring

Year 2025: Major improvements are not anticipated from year 2020 through year 2025. Annual maintenance allows the facility to meet demand through the 5-year horizon.

Year 2030: Provide additional concrete pavement panel replacement, and replace asphalt paving/shoulders.

Year 2035: Major improvements are not anticipated from year 2030 through year 2035. Annual maintenance allows the facility to meet demand through the 5-year horizon.

Year 2040: At this time, the facility will have reached the service life limits for much of the site infrastructure and truck parking will likely require expansion.

C. *Homestead*

A significant amount of work on the Homestead Rest Area is necessary in the near future to bring the facility into code and ADA compliance and provide minimum functionality. Upon completion of this renovation, the rest area will require routine maintenance and some pavement work until full reconstruction is needed.

The following sections generally describe improvements to the facility in 5-year increments starting in year 2020 through year 2040:

Year 2020: The facility was constructed in 1977 and is in need of a significant renovation to provide ADA upgrades and to refurbish the aged infrastructure. As the facility has sufficient capacity, a complete renovation will be more feasible than ongoing maintenance repairs. With this renovation, it is believed that the service life of the facility can be extended to 2040. The following summarizes the 2020 horizon improvements:

- Code Improvements (IBC 2012): Provide GFI outlets, standard storage areas, and additional standard drinking fountain
- ADA Improvements: Provide ramps of correct slope, revise parking signing and striping, modify picnic bench, replace main doors, add accessible restroom stalls and replace phone
- Site Systems: Repair deteriorating pavement, modify main trash lid, replace irrigation system, replace exterior lighting, repair picnic shelters and teepee structure, update landscaping
- Main Building and Building Systems: Completely renovate building with exterior and interior upgrades to walls, windows, doors, and roofing
 - Plumbing System: Renovate piping and fixtures; replace water closets, lavatories, and pipe insulation
 - Mechanical System: Refurbish and replace elements of the mechanical system, including pumps, return air registers, electric heaters, and exhaust fans
 - Electrical System: Replace interior lighting fixtures, circuit breaker panels, CCTV system, and electric hand dryers; enhance internet services and replace alarm

Year 2025: Major improvements are not anticipated from year 2020 through year 2025. Annual maintenance allows the facility to meet demand through the 5-year horizon.

Year 2030: Provide concrete pavement panel replacement and replace portions of the walkways.

Year 2035: Major improvements are not anticipated from year 2035 through year 2040. Annual maintenance allows the facility to meet demand through the 5-year horizon.

Year 2040: By 2040, the site and facility as a whole will have reached age and capacity limitations. Given the extent of renovation projected, plus the costs of a needed addition to support another generation of growth, a new expanded 40-year replacement facility will be of better value at this time extending the useful life goal to 2080. The site infrastructure will need to be expanded and completely overhauled as well (that is, paving, lighting, landscape, shelters, garage, etc.) to also extend service life to 2080.

D. *Hidewood Northbound*

The preservation plan provides for facility and site renovation work sufficient enough to extend the service life of the building to 2030, when the rest area will be approaching the end of its service life and will have begun to exceed capacity limitations. At this time, the building will be ready for an expansion and a complete renovation. Given the scale of work, it will be as or more feasible to provide a new expanded 40-year building. At this same time (2030), it is also recommended to provide a 10-year upgrade of the existing site infrastructure until a full replacement of paving and site amenities will be required in the future (2040).

The following sections generally describe improvements to the facility in 5-year increments starting in year 2020 through year 2040:

Year 2020: The facility was constructed in 1980, renovated in 1992, and requires additional improvements to meet ADA standards and to refurbish components of the aging infrastructure. With this renovation, it is anticipated that the service life of the facility can be extended to 2030.

- Code Improvements (IBC 2012): Provide GFI outlets and additional outlets
- ADA Improvements: Provide parking signs and striping, modify bench, replace entrance door, replace signs, provide phone, reset dispensers, provide accessible stalls
- Parking: Expand truck parking to 24 spaces (detailed in Parking Analysis, **Appendix C**)
- Site Systems: Replace roofing on shelters, replace irrigation system, repair pavement, replace lighting
- Main Building and Building Systems: Replace roof and repair roof deck, trim, and gutters
 - Plumbing System: Replace flush valves with up-to-date units
 - Mechanical System: Replace furnaces with high-efficiency models
 - Electrical System: Replace interior lighting and electric hand dryers; inspect and update power system as needed

Year 2025: Major improvements are not anticipated from year 2020 through year 2025. Annual maintenance allows the facility to meet demand through the 5-year horizon.

Year 2030: Make maintenance improvements to site infrastructure, including pavement, sewage lagoon relining, and renovation of picnic shelters. For the building, a major renovation and expansion of the facility will be needed at a minimum; however, a total replacement facility will be of better value. Total replacement of the building is recommended.

Year 2035: Major improvements are not anticipated from year 2035 through year 2040. Annual maintenance allows the facility to meet demand through the 5-year horizon.

Year 2040: Major improvements are not anticipated for the building from year 2035 through year 2040. Annual maintenance would allow the building to meet demand through the 5-year horizon. A major overhaul of the site infrastructure will be required.

E. *Hidewood Southbound*

The preservation plan provides for facility and site renovation work sufficient enough to extend the service life of the building to 2030, when the rest area will be approaching the end of its service life and will have begun to exceed capacity limitations. At this time, the building will be ready for an expansion and a complete renovation. Given the scale of work, it will be as or more feasible to provide a new expanded 40-year building. At this same time (2030), it is also recommended to provide a 10-year upgrade of the existing site infrastructure until a full replacement of paving and site amenities will be required in the future (2040).

The following sections generally describe improvements to the facility in 5-year increments starting in year 2020 through year 2040:

Year 2020: The facility was constructed in 1980, renovated in 1992, and requires additional improvements to meet ADA standards and to refurbish components of the aging infrastructure. With this renovation, it is anticipated that the service life of the facility can be extended to 2030.

- Code Improvements (IBC 2012): Provide GFI outlets and additional outlets
- ADA Improvements: Provide parking signs and striping, modify bench, replace entrance door, replace signs, provide phone, reset dispensers, provide accessible stalls
- Parking: Expand truck parking to 19 spaces (detailed in Parking Analysis, **Appendix C**)
- Site Systems: Replace roofing on shelters, replace irrigation system, repair pavement, and replace lighting
- Main Building and Building Systems: Replace roof and make repairs to roof deck, trim, and gutters
 - Plumbing System: Replace flush valves with up-to-date units
 - Mechanical System: Replace furnaces with high-efficiency models
 - Electrical System: Replace interior lighting and electric hand dryers; inspect and update power system as needed

Year 2025: Major improvements are not anticipated from year 2020 through year 2025. Annual maintenance allows the facility to meet demand through the 5-year horizon.

Year 2030: Make maintenance improvements to site infrastructure, including pavement, sewage lagoon relining, and renovation of picnic shelters. For the building, a major renovation and expansion of the facility will be needed at a minimum; however, a total replacement facility will be of better value. Total replacement of the building is recommended.

Year 2035: Major improvements are not anticipated from year 2035 through year 2040. Annual maintenance allows the facility to meet demand through the 5-year horizon.

Year 2040: Major improvements are not anticipated for the building from year 2035 through year 2040. Annual maintenance would allow the building to meet demand through the 5-year horizon. A major overhaul of the site infrastructure will be required.

F. Tilford Eastbound

The facility, at a minimum, will need immediate ADA improvements, component updates, a new lighting system, and other upgrades. Given the extent of work immediately required, a general renovation is recommended as soon as possible. By providing a complete renovation, the service life of the facility will be extended to 2040, when the facility will be ready for replacement with a new and larger facility.

The following sections generally describe improvements to the facility in 5-year increments starting in year 2020 through year 2040:

Year 2020: The facility was constructed in 1973 and is in need of a renovation to address ADA deficiencies and to upgrade and refurbish components of the aging infrastructure. With this renovation, the service life of the facility can be extended to 2040 when it will be nearing capacity and will be ready for replacement.

- Code Improvements (IBC 2012): Provide GFI outlets, standard storage areas, and accessible drinking fountain; replace information counters
- ADA Improvements: Address parking lot grade issues, improve signage, modify bench, replace main doors and interior signage, provide new public phone, rest dispensers, provide accessible stalls, modify counters, widen door between information area and storage, provide accessible restroom stalls
- Site Systems: Regular lagoon upgrade, replace irrigation system, replace water pump, repair pavement deficiencies, replace lighting fixtures, inspect structures, and refurbish picnic shelters
- Parking: Expand truck parking to 18 spaces
- Main Building and Building Systems: Replace failing information booth gate system, renovate building including exterior and interior walls, roofing, insulation, windows, doors and flooring
 - Plumbing System: Renovate plumbing (piping and fixtures), replace water closets and urinals, replace sinks, and provide protected bottle filler
 - Mechanical System: Operate exhaust air continuously, install energy recovery units, and replace outdoor AC unit and exhaust fan
 - Electrical System: Replace interior lighting and replace/inspect power system, hand dryers, and CCTV system

Year 2025: Major improvements are not anticipated from year 2020 through year 2025. Annual maintenance allows the facility to meet demand through the 5-year horizon.

Year 2030: Repair pavement deficiencies; replace ramp, parking, and pedestrian lighting

Year 2035: Major improvements are not anticipated from year 2035 through year 2040. Annual maintenance allows the facility to meet demand through the 5-year horizon.

Year 2040: By 2040, the facility will have reached the service life limits for both the facility and the site infrastructure. The facility will also be reaching capacity and require an expansion of both the building and the parking areas. Given the extent of renovation projected, plus the costs of the addition, a new expanded 40-year replacement facility will be of better value at this time providing a new useful life goal to 2080.

G. Tilford Westbound

The facility, at a minimum, will need immediate ADA improvements, component updates, a new lighting system, and other upgrades. Given the extent of work immediately required, a general renovation is recommended as soon as possible. By providing a complete renovation, the service life of the facility will be extended to 2040, when the facility will be ready for replacement with a new and larger facility.

The following sections generally describe improvements to the facility in 5-year increments starting in year 2020 through year 2040:

Year 2020: The facility was constructed in 1973 and is in need of a significant renovation to provide ADA upgrades and to refurbish the mostly original infrastructure. With this renovation, the service life of the facility can be extended to 2040 when it will be nearing capacity and will be ready for replacement.

- Code Improvements (IBC 2012): Provide GFI outlets, standard storage areas, and accessible drinking fountain; replace information counters
- ADA Improvements: Address parking lot grade issues, improve signage, modify bench, replace main doors and interior signage, provide new public phone, provide rest dispensers, provide accessible stalls, modify counters, widen the door between the information area and storage, provide accessible restroom stalls
- Site Systems: Regular lagoon upgrade, replace irrigation system and water pump, repair pavement deficiencies, replace lighting fixtures, inspect structures, and refurbish picnic shelters
- Parking: Expand truck parking to 13 spaces
- Main Building and Building Systems: Replace failing information booth gate system, renovate building including exterior and interior walls, roofing, insulation, windows, doors and flooring
 - Plumbing System: Replace water closets and urinals, replace sinks, provide protected bottle filler
 - Mechanical System: Operate exhaust air continuously, install energy recovery units, replace outdoor AC unit and exhaust fan
 - Electrical System: Replace interior lighting and replace/inspect power system, hand dryers, and CCTV system

Year 2025: Major improvements are not anticipated from year 2020 through year 2025. Annual maintenance allows the facility to meet demand through the 5-year horizon.

Year 2030: Repair pavement deficiencies and replace ramp, parking, and pedestrian lighting

Year 2035: Major improvements are not anticipated from year 2035 through year 2040. Annual maintenance allows the facility to meet demand through the 5-year horizon.

Year 2040: By 2040, the facility will have reached the service life limits for both the facility and the site infrastructure. The facility will also be reaching capacity and require an expansion of both the building and the parking areas. Given the extent of renovation projected, plus the costs of the addition, a new expanded 40-year replacement facility will be of better value at this time providing a new useful life goal to 2080.



H. Preservation Cost Estimates

The project team developed estimated costs associated with the preservation plans for each rest area, as shown in **Table 7**.

Table 7. Cost of Preservation by Rest Area

Rest Area	Five-year Horizon Costs, Year of Expenditure Dollars				
	2013–2020	2020–2025	2025–2030	2030–2035	2035–2040
Valley Springs	\$1.45 M	\$325,000	\$668,000	\$502,000	\$12.30 M
Homestead	\$1.52 M	\$335,000	\$532,000	\$410,000	\$12.13 M
Hidewood Northbound	\$1.20 M	\$345,000	\$2.6 M	\$531,000	\$ 9.75 M
Hidewood Southbound	\$1.06 M	\$345,000	\$2.6 M	\$531,000	\$ 9.75 M
Tilford Eastbound	\$1.93 M	\$304,000	\$932,000	\$469,000	\$12.26 M
Tilford Westbound	\$2.24 M	\$304,000	\$798,000	\$469,000	\$12.26 M
TOTALS	\$9.40 M	\$1.96 M	\$8.13 M	\$2.91 M	\$68.45 M

V. BENEFIT COST AND PRIORITIZATION

SDDOT currently faces critical decisions regarding future maintenance for many facilities within the rest area system. Rest areas across the state are beginning to reach the end of their useful lives and SDDOT must either reconstruct the facilities or continue making essential repairs to extend the facilities' lifespans. This decision is complicated by limited funds and the fact that SDDOT does not use bonds to fund capital investments.

The project team developed an analytical framework to approach this multifaceted problem. The framework uses priorities set by SDDOT to integrate the engineering and architectural studies conducted with financial and prioritization analysis based on costs and benefits of alternative investment strategies. This section describes the strategic facilities management approach used by the project team. It also includes the financial analysis and future recommendations.

A. Strategic Facilities Management Approach

Strategic facilities management is a planning process that allows planners to make complex decisions about the development, expansion, and maintenance of their capital investments. This complicated process often requires making decisions based on multiple variables and uncertainties. To simplify the decision process, facility managers need to develop concise goals and priorities that can then be translated into construction and maintenance objectives and eventually into concrete strategies and actions.

The Planning Process

Whether the analysis is for a chemical plant, a university, or a rest area, the same general steps can help guide maintenance decisions toward a successful outcome.

Step 1. Document clear high-level goals and objectives. Planners must make important decisions about their priorities. This is often a vision of what the organization should look like after a certain time period. If clear goals are not well established, it is difficult to make consistent decisions throughout the complex decision making process.

Step 2. Evaluate current conditions. To determine what must be done to achieve the goals established in Step 1, there must be a detailed understanding of the current situation. This includes a complete inventory of sites, capital costs, labor costs, and other inputs that are critical to success.

Step 3. Analyze capital needs. Once the current conditions have been examined, "gap analysis" can be conducted. "Gap analysis" simply means that there is a clear understanding of the difference between the current situation and future needs. This will reveal the concrete construction and maintenance needs that can then be prioritized according to their ability to contribute to the high-level objectives. These needs then can be conceptualized in a facility life plan, or a strategic schedule to maintain each unit throughout its expected useful life.

Step 4. Conduct financial and risk analysis. Unfortunately, it is unrealistic to assume that the entire gap can be covered under a typical budget. Therefore, the established needs must be balanced against monetary realities. This step typically involves return on investment (ROI), net present value (NPV), and internal rate of return (IRR) analysis. Life cycle and whole life cost analysis can also assist in this decision making process. This will enable planners to better understand the costs of all the maintenance items. These costs can be compared to the benefit of the investment and then can be used to make a cost/benefit rating for all the alternatives and needs.

Step 5. Recommendations and alternatives. Based on the analysis from the previous steps, planners can recommend a strategic action plan. It is important to develop various alternative scenarios that are all consistent with the high level objectives. This creates flexibility so that effective decisions can be made even as conditions change.

SDDOT and the consultant team have completed these steps through the Rest Areas Study.

The Maintenance Decision

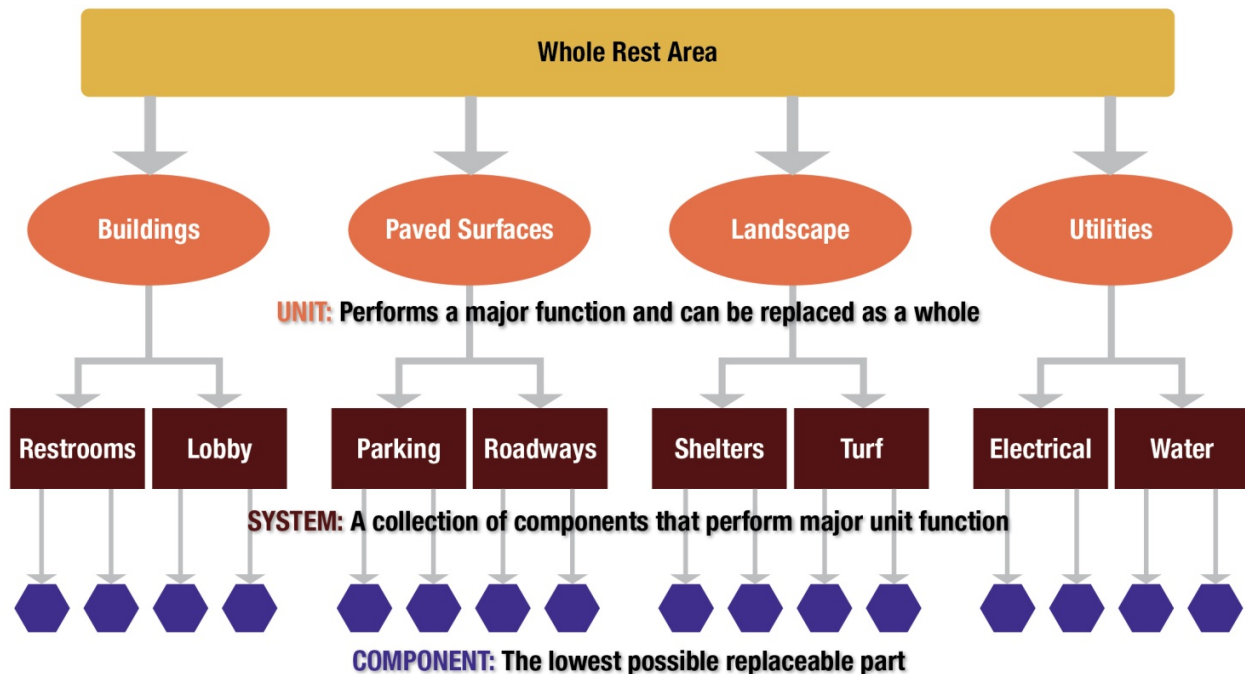
While the steps above can help planners navigate the decision making process, it can still be difficult to accurately evaluate every specific maintenance item and building system. Maintenance is a complex process that addresses a wide range of actual and potential system failures. A failure is said to occur when a part can no longer meet its designated function. Failures can either be partial, meaning impacts are isolated, or complete, meaning there are facility wide consequences. All failures are addressed in one or two ways; there are either preventive steps that are conducted before the failure occurs or corrective steps that are a response to an active failure.

A facility system is made up of complex attributes that all work together to achieve a certain objective. To make efficient decisions, it helps to approach the problem by dividing the larger facility into more manageable parts that can be evaluated independently.

The Hierarchy of Parts

A rest area can be broken down into groups of parts organized by function. **Figure 14** illustrates this hierarchy, in wherein a rest area is made up of units, systems, and components.

Figure 14. Hierarchy of Parts



Source: Strategic Maintenance Planning, Anthony Kelly

The repair or replace decision. Once this hierarchy has been established, it can be used to develop a facility life plan. Over time, every part of the facility will deteriorate to the point where it must be either repaired or replaced. While this is a common problem, it is not necessarily an easy decision. Strategic planners propose that there are typically three ways to respond to the repair/replace decision: Always repair, always replace, or wait until the decision making failure happens.

The best course of action depends on the failure mode, or the manner in which the part fails. Items higher on the hierarchy have more potential failure modes because there are larger combinations of ways for the part to fail. Evaluating parts based on where they are in the hierarchy can aid in decision making because it consolidates all of the possible failure modes into comprehensive elements. It can also indicate what approach might be best suited for the part, depending on where it is in the hierarchy. For higher level units with many potential failure modes, it is often best to wait until the failure causing event occurs. Complete replacement is likely expensive and can often be addressed by making repairs to lower level parts as warranted. However, if there is a high probability of multiple failure modes, it may be best to completely replace the part in question. For lower level, less complex, components, it is usually helpful to look at statistical failure rates. Components that are likely to fail are often most efficient to replace before failure.

However, no matter where the part is within the hierarchy, for decisions to maximize efficiency, the continued cost of repair must be less than the cost of replacement. Preventative maintenance tends to be less expensive at one point in time; however, costs increase as more repairs must be made. Eventually it will be less expensive to replace the item than to make repeated repairs.

The project team used the above strategic facility maintenance process to determine a favorable year for facility replacements for seven rest areas in the SDDOT system. The team also established a prioritization method that will help SDDOT make future facility maintenance decisions.

B. Rest Area Study Process

The Needs Assessment in **Appendix D** includes the detailed analysis for individual components and systems at each facility and the preservation plan cost estimates. The financial analysis to support SDDOT in making efficient maintenance decisions is described as follows.

As major building systems in rest area facilities deteriorate, SDDOT must decide to either rebuild the facilities or delay reconstruction by preserving major systems in the aging facilities. Most individual maintenance problems do not warrant complete replacement; however, there are two situations when investing in a new facility is preferable to conducting continual repairs. The first is when a single catastrophic facility failure occurs that would be more expensive to fix independently than it would be to build a new facility. The second, and more likely situation, is that during a given time horizon, continually repairing a facility will become more expensive than building a new facility. When this occurs, it is no longer financially efficient to continue maintaining the facility.

The project team established facility replacement recommendations for each rest area in the study by comparing potential costs of various repair plans for each facility. Each repair plan includes annual maintenance, repairs, and construction of a new facility. The plans differ depending on when the facility is rebuilt, which, in turn, affects the total cost of each plan. When SDDOT delays reconstruction, facilities deteriorate and require more expensive maintenance



and repairs. This cost of continual preservation for each rest area was calculated in the Needs Assessment. Alternatively, as soon as a facility is rebuilt, maintenance and repair costs are significantly lower; although these costs will increase again as the facility ages.

For each rest area facility, the project team calculated the present value of 26 repair plans. Each repair plan simulates rebuilding the rest area in a different year between 2014 and 2040. Appropriate repair and maintenance costs are applied in accordance with the age of the facility. For example, if SDDOT rebuilds a facility in 2014, maintenance costs will be very low initially, but the facility will require additional repairs as the facility ages. Alternatively, if SDDOT does not replace the facility until 2030, then SDDOT must pay to preserve the facility for the next 16 years as well as the cost of reconstruction in 2030. This plan also includes the diminished annual maintenance costs after a new facility is constructed. If SDDOT delays reconstructing the facility until 2040, the facility will require expensive preservation for 25 years before it is rebuilt. This plan includes both the preservation and new facility costs but does not benefit from the diminished annual maintenance costs after the new facility is constructed.

C. Repair Plan Calculations

While each rest area is unique and will require different repairs over time, the study model includes calculations for each repair plan based on several general assumptions. **Table 8** summarizes the assumptions included in the model.

Table 8. Assumptions for Facility Reinvestment Model

Assumption		
Present value calculations		
Escalation rate	4.43%	per year
Discount rate	4.43%	per year
Annual increase in preservation plan costs	12%	per year
Cost of preservation through 2040*	\$5.8-\$7.0	million
New facility cost†	\$3.15	million
Maintenance costs		
Annual maintenance on a new facility	\$10,000	per year
Periodic reinvestments (percent of new facility cost)	8%	every 10 years
	15%	every 20 years

Note: *Preservation plans differ between rest areas.

†New facility cost for the Valley Springs POE is approximately \$2.7 million

Source: SDDOT, TSP, FHU, and BBC Research and Consulting, 2014.

These assumptions were based on various conversations with the SAT. It is estimated that preservation costs for deteriorating facilities increase approximately 12 percent per year. Further, it is estimated that a new facility, sized to future capacity, would cost approximately \$3.1 million in 2014 dollars to construct. For the Valley Springs POE facility, the replacement cost would be approximately \$2.7 million. Given SDDOT’s current practice to use identical discount and cost escalation rates, these values stay constant across the time horizon.



General maintenance is \$10,000 per year for a new facility, which is approximately 25 percent of current annual facility maintenance costs. Because the new facilities will eventually deteriorate with age, it is assumed that periodically the facilities will require larger reinvestments. These reinvestment costs represent repairs made on larger parts, such as the lagoon, parking lot, or lighting system. This model assumes that 8 percent of cost of a new facility will be reinvested every 10 years and 20 percent will be invested every 20 years.

The preservation plans included estimated costs of preserving the rest areas to the Year 2040, in 5-year intervals. The present value of these plans ranges from \$5.8 million to \$7 million over 26 years. To complete the financial analysis, it was assumed that the costs occur evenly over the 5-year intervals. In practice, the costs are likely concentrated in specific years according to the actual repairs. Therefore, the results presented do not necessarily show the precise costs for each given year. Instead, they suggest a general estimate of costs during that time period.

D. Results

Using the methodology described above, the project team calculated the present value of all potential repair plans for every rest area in the study. Results for Hidewood North Rest Area are discussed below as an example, with complete results included in **Appendix E**.

Given the age and condition of all facilities in the study, SDDOT can minimize costs by reconstructing new facilities as soon as possible. Preserving existing facilities is expensive and SDDOT would financially benefit by investing in new facilities immediately. However, due to budget constraints, it is not feasible to suggest rebuilding all facilities at this time. Instead, these financial analyses enable SDDOT to consider the costs of deferring significant investments.

The most efficient repair plan minimizes the present value of future annual facility expenditures. **Figure 15** summarizes the total present value for the various repair plans for Hidewood North.

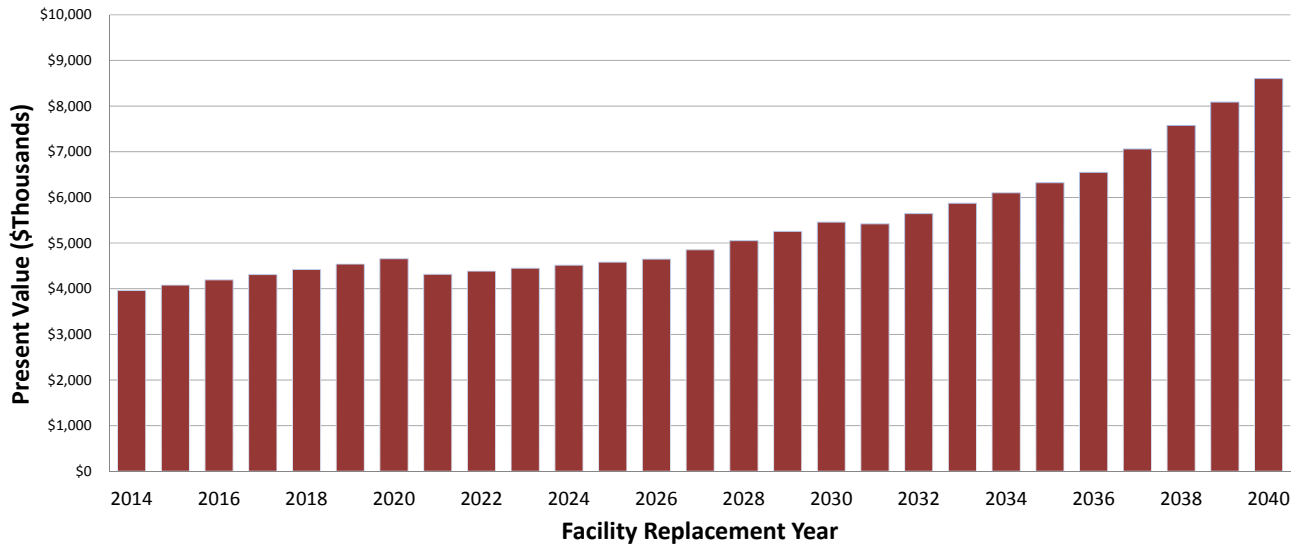
Each column represents a different repair plan, depending on when the rest area will be rebuilt. The first column on the left labeled “2014” shows the total value of rest area construction and maintenance costs if the facility is rebuilt in 2014. Each subsequent column represents the costs of preserving the facility until the designated year, rebuilding the facility, and annual maintenance after reconstruction.

As evident in **Figure 15**, costs can be minimized by immediately rebuilding the rest area facility. Like many rest areas in SDDOT’s system, Hidewood North is approaching the end of its useful life. The present value analysis recommends rebuilding it as soon as possible because preservation becomes increasingly expensive over time. It will cost SDDOT approximately \$4 million more over 26 years to rebuild Hidewood North in 2040 than to rebuild it in 2014.

Although costs increase when SDDOT delays rebuilding the facility, the analysis suggests that, on the margin, preserving the rest area until approximately 2030 does not add significant amounts to the total costs. However, it is not advisable to delay rebuilding the facility beyond 2030 because preservation costs begin to increase at a faster rate.

The preservation plan provides a cost-effective method for SDDOT to delay rebuilding facilities. For Hidewood North, the plan can extend the useful life of the facility until 2030 without adding prohibitive costs. However, this preservation window eventually closes and SDDOT must rebuild the facility or incur markedly higher costs.

Figure 15. Present Value of Repair Plans – Hidewood North



Note: Total present value of the preservation plan through 2040 is \$6.1 million, not including the value of a new facility.
 Source: TSP and BBC Research & Consulting. 2014.

E. Cost-Benefit Prioritization

For rest areas, public benefit is derived from services provided to users. Useful metrics to analyze the benefits from various rest areas are total visitors and visitor hours. Using visitor hours rather than total visitors prioritizes truck usage because truckers are more likely to take long breaks at rest area. The project team calculated projected total visitor hours for all rest areas. These values were based on visitor projections and parking duration estimates described in Section 3 of the report.

Visitation calculations were then compared to projected costs of preservation through 2040 and the present value of a new facility. **Table 15** and **Table 16** show these calculations.

Rest areas with lower investment costs per visitor hour are facilities where the recommended investments serve the most people. Therefore, these facilities produce the most public benefit for the money spent on repairs. **Table 9** presents the present value of the preservation plans through 2040, and **Table 10** shows the investment per visitor hour for a new facility at each rest area. These values can help SDDOT prioritize facility replacements.

Table 9. Preservation Investment per Visitor Hour

	Total Visitor Hours 2015-2040	Preservation Costs through 2040	Preservation Investment per Visitor Hour
Hidewood South	3,917,353	\$5,795,306	\$1.48
Hidewood North	3,739,290	\$6,103,503	\$1.63
Valley Springs RA	3,289,353	\$6,202,527	\$1.89
Tilford East	2,607,355	\$7,043,987	\$2.70
Tilford West	2,374,695	\$7,719,043	\$3.25
Homestead	1,963,344	\$6,897,049	\$3.51
Valley Springs POE	1,348,173	\$6,103,503	\$4.53



Table 10. New Facility Investment per Visitor Hour

	Total Visitor Hours 2015-2040	Present Value of a New Facility	New Facility Investment per Visitor Hour
Hidewood South	3,917,353	\$3,153,786	\$0.81
Hidewood North	3,739,290	\$3,153,786	\$0.84
Valley Springs RA	3,289,353	\$3,153,786	\$0.96
Tilford West	2,374,695	\$3,153,786	\$1.33
Tilford East	2,607,355	\$3,153,786	\$1.21
Homestead	1,963,344	\$3,153,786	\$1.61
Valley Springs POE	1,348,173	\$2,506,320	\$1.86

While the Valley Springs POE ranks poorly in this analysis, it is difficult to compare it to other facilities because it meets a different function and need. Prioritization for the POE facility requires independent consideration.

Using these metrics, SDDOT should replace the Hidewood South Rest Area first because it will provide the most value to future visitors. Preservation and reconstruction of rest areas at Hidewood North and Valley Springs should also be high priorities for SDDOT. The rest areas at Tilford East and Tilford West serve fewer visitor hours and have higher costs than other facilities, making them less valuable investments. When compared to other rest areas in this study, the Homestead rest area is the most expensive to preserve and is the least used by visitors.

F. Other Priority Considerations

This study analyzed rest areas on the facility level. It may be necessary to make crucial repairs at various locations regardless of facility investment per visitor figures. If disregarded, these maintenance items could result in total facility failure and may need to be remedied before that occurs.

There may also be repairs that are most efficient to coordinate among rest areas. Once equipment has been rented and crews have been hired, it could potentially be financially efficient to combine maintenance work at multiple locations. This may be particularly applicable for projects such as repaving parking lots.

This study considers facilities individually, not as part of an entire rest area system. When analyzed as part of the system, it may become evident that certain rest areas are either more or less significant. For example, it may be more important to invest in a facility that is comparatively isolated where there are no other functional rest options than to repair a heavily used facility that is in closer proximity to other rest areas or potential stops.

G. Final Recommendations

Results from the architectural and financial analysis indicate that current facilities in SDDOT’s rest area system are rapidly deteriorating and are becoming increasingly expensive to preserve. As funds become available, the department should prioritize reconstructing the facilities according to the ranking shown in **Table 10**. Replacing the rest areas as soon as possible will minimize total costs over the next 25 years, as well as better serve visitor needs.



The Interstate Rest Areas Study: Along the I-29 and I-90 Corridors

To operate within the annual budget, rest area reconstruction will likely need to take place over time. Making essential repairs, outlined in the Needs Assessment, can help preserve the existing facilities until they can be rebuilt. These repair plans can extend the lifespan of the facilities by between 20 and 25 years, depending on the rest area, without significantly increasing total costs. This should provide SDDOT time to make the necessary facility replacements without incurring prohibitively high costs; however all rest areas should be replaced as soon as possible, and certainly before the preservation window closes.



VI. SUMMARY OF FINDINGS AND RECOMMENDATIONS

SDDOT has completed a study of seven rest areas along Interstates 90 and 29 in South Dakota. The purpose of the study is to assess rest area conditions, provide a plan for preserving the ability of these rest areas to continue to meet demand, and determine when to stop investing funds into preservation and channel monies toward constructing a new facility. The seven rest areas include six traditional general public rest areas and one POE:

- Valley Springs Westbound I-90
- Valley Springs Port of Entry Westbound I-90
- Homestead Northbound/Southbound I-29
- Hidewood Northbound I-29
- Hidewood Southbound I-29
- Tilford Eastbound I-90
- Tilford Westbound I-90

The Rest Areas Study included a data collection effort focused on identifying current rest area performance and condition, addressing parking capacity and building and infrastructure condition. The data collection efforts identified many issues and deficiencies, ranging from truck parking demand nearing capacity to non-ADA compliant restrooms. Forecasted future increases in parking and visitor demand revealed additional deficiencies in need of correction.

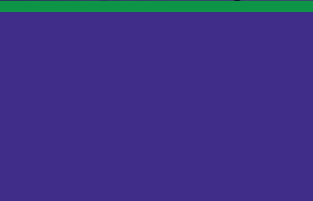
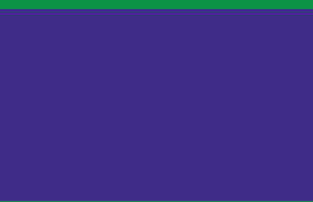
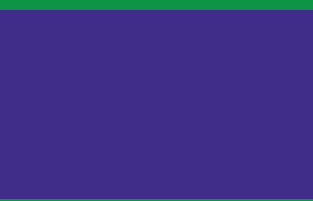
The project team collaborated with a Study Advisory Team (SAT) made up of SDDOT representatives to consider the issues identified and develop a plan for investing in the rest areas to preserve their functionality. The plan includes a list of needs at each rest area, projects necessary to meet those needs between the Years 2013 and 2040, and the costs associated with accomplishing the work grouped into 5-year increments.

Strategic facilities management methods were applied to evaluate the rest area preservation plans from a financial perspective, weighing the costs and benefits associated with the decision to continue to preserve the rest areas or replace them. Study results indicate that current facilities in SDDOT’s rest area system are rapidly deteriorating and are becoming increasingly expensive to preserve. As funds become available, the department should prioritize reconstructing the facilities according to the ranking shown below, based on dollars invested per visitor hour:

- | | |
|-----------------------------|----------------------|
| 1. Hidewood Southbound | 4. Tilford Westbound |
| 2. Hidewood Northbound | 5. Tilford Eastbound |
| 3. Valley Springs Westbound | 6. Homestead |

Replacing the rest areas as soon as possible will minimize total costs over the next 25 years, as well as better serve visitor needs.

To operate within the annual budget, rest area reconstruction will likely need to occur time. Making the essential repairs outlined in the Needs Assessment can help preserve the existing facilities until they can be rebuilt. These repair plans can extend the lifespan of the facilities by between 20 and 25 years, depending on the rest area, without significantly increasing total costs. This should provide SDDOT time to make the necessary facility replacements without incurring prohibitively high costs; however all rest areas should be replaced as soon as possible, and certainly before the preservation window closes.



www.fhueng.com

6300 South Syracuse Way, Suite 600 | Centennial, CO 80111 | tel 303.721.1440





Appendix A. Methods and Assumptions Document for the Rest Areas Study

SDDOT REST AREA STUDY
SOUTH DAKOTA
METHOD AND ASSUMPTIONS
DOCUMENT

Prepared for:

South Dakota Department of Transportation
700 East Broadway Avenue
Pierre, South Dakota 57501-2586
(605) 773-3093

Federal Highway Administration
116 East Dakota Avenue, Suite A
Pierre, South Dakota 57501
(605) 224-8033

Prepared by:

Felsburg Holt & Ullevig
6300 South Syracuse Way, Suite 600
Centennial, CO 80111
(303) 721-1440

FHU Reference No. 13-039-01
August 2013

TABLE OF CONTENTS

	<u>Page</u>
I STAKEHOLDER ACCEPTANCE	1
II INTRODUCTION AND PROJECT DESCRIPTION	2
A. Background Information	2
B. Location	2
C. Purpose	3
D. Schedule	3
E. Facility Impact	3
F. Team Members	3
III STUDY AREA	4
IV ANALYSIS PERIODS	4
V DATA COLLECTION	4
VI TRAFFIC OPERATIONS ANALYSIS	5
VII TRAVEL FORCEAST	5
VIII SAFTEY ISSUES	5
IX MEASURES OF EFFECTIVENESS (MOE)	6
X FHWA INTERSTATE ACCESS MODIFICATION POLICY POINTS	6
XI DEVIATIONS / JUSTIFICATIONS	6

APPENDIX A

I STAKEHOLDER ACCEPTANCE

The undersigned parties concur with the Methods and Assumptions for the SDDOT Rest Area Study as presented in this document.

FHWA

Paul Koenig
Signature

Planning/Civil Rights Specialist
Title

8/29/2013
Date

SDDOT

Bob Re
Signature

Transportation Specialist II
Title

8-30-2013
Date

Participation of the Study Advisory Team and/or signing of this document does not constitute approval of the SDDOT Rest Area Study's Final Report or conclusions.

All members of the Study Advisory Team will accept this document as a guide and reference as the study progresses through the various stages of development. If there are any agreed upon changes to the assumptions in this document a revision will be created, endorsed and signed by all the signatories.

II INTRODUCTION AND PROJECT DESCRIPTION

A. Background Information

South Dakota's Interstate rest areas face a number of current challenges and trends anticipated to continue into the future, and this study is positioned to keep the system and individual rest areas ahead of the curve to meet the needs of users and the priorities of the State of South Dakota.

A few challenges include:

- *Aging Facilities:* The aging of rest area infrastructure necessitates the development of a future plan for maintaining and upgrading facilities. The system has adapted and thrived through many changes in transportation culture and technology. The study will highlight improvements to ensure that rest areas continue to do so.
- *Increasing Traffic:* Passenger cars, motorcycles, RVs, commercial trucks and buses together place significant demand on the rest area system, and traffic will only increase into the future. Tourist visits are on the rise and Interstate traffic volumes are expected to increase by up to 50 percent by the Year 2030. Interstate truck traffic in South Dakota is expected to increase to carry tens of thousands of long haul freight trucks per day by the Year 2040 (FHWA). The study will recommend improvements to accommodate the parking, access, and facility demands of a surging number of users.
- *Constrained Funding:* The SDDOT continues to rise to the challenge of meeting the State's highway needs out of a constrained funding pool. Money for highway and rest area projects comes from a variety of sources in relatively small amounts, so the available resources must be carefully allocated to meet priority needs. An important outcome of the study will be a prioritized listing that will allow critical projects to be matched with available funding.

B. Location

The seven specific rest areas that will be analyzed in this study are located along the Interstate 90 and Interstate 29 corridors and represent the rest areas which show the greatest need for improvement. These rest areas include:

- Valley Springs (I-90 westbound at MRM 412)
- Valley Springs POE (I-90 westbound at MRM 412)
- Homestead (I-29 NB/SB at MRM 26)
- Hidewood Northbound (I-29 NB at MRM 160)
- Hidewood Southbound (I-29 SB at MRM 160)
- Tilford Eastbound (I-90 EB at MRM 41)
- Tilford Westbound (I-90 WB at MRM 41)

C. Purpose

The purpose of this study is to update and enhance the existing rest area AuditMate inventory, collect and analyze rest area usage during a typical day, identify rest area deficiencies and the cost of needed improvements, and recommend enhancements to existing rest area facilities to meet future demand.

D. Schedule

It is anticipated that the project can be completed in six months from notice to proceed. The following graphic illustrates the schedule in detail:

Scope Task #	Scope Task	2013				2014		
		Sep	Oct	Nov	Dec	Jan	Feb	Mar
1	Literature Review	█						
2	Methods and Assumptions	█	█					
3	Facility Assessment	█	█	█				
4	Facility Use Data Collection	█	█					
5	Truck Parking Analysis		█	█	█			
6	Facility Needs Assessment			█	█			
7	Prioritizing Methodology			█	█			
8	List of Improvements				█	█		
9	Facility Size Assessment					█	█	
10	Documentation					█	█	

E. Facility Impact

The seven rest areas will be studied in detail during a 24 to 48 hour period. During that time it is anticipated that day-to-day operations will not be impacted significantly, and each facility will remain open and functioning to the traveling public during the data collection process.

F. Team Members

The following table summarizes the key members of the project team:

Felsburg Holt and Ullevig	
Jeremy Hahn – Project Manager	Lyle DeVries – Principal in Charge
South Dakota Department of Transportation	
Brad Remmich – Project Manager	
FHWA	
Mark Hoines – Project Manager	
TSP	
Robert Morcom – Principal in Charge	Tim Roach – Project Architect
Elizabeth Obaka – Project Architect	
All Traffic Data	
Eric Boivin – Project Manager	
BBC	
Todd Pickton – Managing Director	Adam Orens - Director

III STUDY AREA

The study area for each rest area is generally bound by property / right-of-way line and at the pavement cut separating the rest area from the adjacent transportation network. This includes, but is not limited to, each structure contained within the property boundary, the pavement / parking areas, and water quality features.

The following list summarizes the list of rest areas that are included in the study area:

- Valley Springs (I-90 westbound at MRM 412)
- Valley Springs POE (I-90 westbound at MRM 412)
- Homestead (1-29 NB/SB at MRM 26)
- Hidewood Northbound (I-29 NB at MRM 160)
- Hidewood Southbound (I-29 SB at MRM 160)
- Tilford Eastbound (I-90 EB at MRM 41)
- Tilford Westbound (I-90 WB at MRM 41)

IV ANALYSIS PERIODS

The study will review typical weekday conditions during summer months. The usage of rest areas in South Dakota drops significantly during the winter months, so the study will focus only on the summer period.

As is discussed in the following section, the data collection effort will occur over several weeks starting in September, with traffic / parking data and the infrastructure inventory collected at different times. The traffic, parking, water and wastewater data collected in September 2013 will be calibrated to peak summer conditions using historical data from SDDOT. The calibrated data will become the baseline peak analysis period.

The study will review existing conditions (year 2013) and year 2035 (22 years) will be set to define the long term impacts and facility enhancements at each rest area.

V DATA COLLECTION

The data collection will occur in two major phases. The first phase includes the traffic and parking count. On a weekday agreed to by the project team (anticipated to occur the 2nd or 3rd week of September 2013), video collection data will be placed at each rest area by ATD staff and will be run for a 24-hour period. The video will capture both passenger car and heavy vehicle parking counts, as well as ingress / egress volumes. Since the peak tourist season has passed (historically June through July), parking counts will be calibrated to the peak season using historical daily traffic counts conducted by SDDOT staff at the rest area ingress / egress points and historical seasonal factors. The following lists the historical September seasonal traffic factors at each rest area:

Tilford – 0.79 Seasonal Factor	Valley Springs – 0.79 Seasonal Factor
Hidewood – 0.90 Seasonal Factor	Homestead – 0.90 Seasonal Factor

At the Homestead rest area, a facility which is accessed via State Highway 50, existing turning movement counts at the access point will be derived from historical daily traffic counts on State Highway 50 collected by SDDOT and the ingress / egress volumes from the video collection.

The second phase of data collection will include the facility assessment of each rest area. A weekday during the 2nd or 3rd week of September 2013 will be selected by the project team for each rest area. The inventory will be conducted by TSP staff and will include representatives from SDDOT maintenance staff. An on-site meeting will be held to determine site specific issues / concerns from SDDOT staff which will guide the inventory process. During this time, utilities (water) may be shut off for a small period of time but will not impact facility use by the traveling public.

VI TRAFFIC OPERATIONS ANALYSIS

Operational analysis will be based on procedures documented in the *Highway Capacity Manual 2010*, (Transportation Research Board, 2010). More specifically, the following chapters of the HCM will be used to analyze specific operational conditions:

Mainline I-29 and I-90 Level of Service

- Chapter 11 – Basic Freeway Segments
- Chapter 13 – Freeway Merge and Diverge Segments

Homestead Rest Area Level of Service

- Chapter 19 – Two-Way Stop Controlled Intersections

It is anticipated that the most current version the Highway Capacity Software package will be utilized for the project. Parking counts will be analyzed by calculating both parking occupancy and parking duration throughout the 24-hour period. These two metrics will help to define parking issues at each rest area.

VII TRAVEL FORECAST

Future use of the rest area facilities will be determined using historical traffic counts at each rest area facility, historical 10-year ATR data on I-90 and I-29, and historical planning studies which reviewed future traffic conditions along the South Dakota Interstates including, but not limited to, *NCHRP Synthesis 317 Dealing with Truck Parking Demands, A Synthesis of Highway Practice*, 2003 and *Commercial Driver Rest & Parking Requirements: Making Space For Safety*, FHWA, 1996. The current SDDOT growth factors for each rest area are as follows:

Tilford – 1.28 Growth Factor	Valley Springs – 1.52 Growth Factor
Hidewood – 1.35 Growth Factor	Homestead – 1.44 Growth Factor

VIII SAFETY ISSUES

Specific accident data will not be analyzed as part of this project. However, safety issues outlined by SDDOT maintenance staff during the facility assessment will be incorporated into the analysis.

IX MEASURES OF EFFECTIVENESS (MOE)

The following outline the specific MOE's that will be utilized in the project:

- Traffic - Freeway and intersection operations at each rest area ingress / egress point will be quantified using HCM level of service thresholds. The LOS for a freeway segment is a function of three variables which include free flow speed, flow rate and density. Merging and diverging operations take into account factors including conflicting traffic flows, merging / diverging distances and density.
- Infrastructure – Design life will be used to quantify specific items inventoried in the AuditMate software. A combination of design life, replacement cost and on-going maintenance costs will be used to develop the methodology for improving specific rest areas.

X FHWA INTERSTATE ACCESS MODIFICATION POLICY POINTS

Additional access will not be gained onto either I-29 or I-90.

XI DEVIATIONS / JUSTIFICATIONS

We do not anticipate any deviations from stated standards.

APPENDIX A



Appendix B. Facility Assessment

**VALLEY SPRINGS WESTBOUND
REST AREA**

TECHNICAL REVIEW REPORT

Prepared for:

Mr. Brad Remmich
South Dakota Department of Transportation
Office of Project Development
700 East Broadway Avenue
Pierre, SD 57501-2586
(605) 773-3093

Prepared by:

TSP
600 Kansas City Street
Rapid City, SD 57701-2712
(605) 343-6102

Felsburg Holt & Ullevig
6300 South Syracuse Way, Suite 600
Centennial, CO 80111
(303) 721-1440

FHU Reference No. 113039-01
December 2013



TABLE OF CONTENTS

	<u>Page</u>
I. INTRODUCTION -----	1
II. GENERAL OVERVIEW -----	1
A. Rest Area Layout -----	2
B. Field Visit Observations -----	4
C. User Environment -----	4
D. Existing Building Code Conformity -----	5
E. Americans with Disabilities Act (ADA) Survey -----	5
F. Energy and Water Usage Review -----	7
III. BUILDING SYSTEM OVERVIEW -----	8
A. Architectural System -----	8
B. Plumbing System -----	8
C. Mechanical System -----	9
D. Electrical System -----	9
E. Sanitary Sewer System -----	9
F. Water System -----	9
G. Infrastructure -----	10
IV. SUMMARY -----	11

APPENDIX A MAINTENANCE STAFF MEETING MINUTES

APPENDIX B ADA SURVEY RESULTS

APPENDIX C AUDITMATE SUMMARY

LIST OF FIGURES

	<u>Page</u>
Figure 1. Valley Springs Westbound Rest Area Site Layout -----	3



I. INTRODUCTION

The Valley Springs Westbound Rest Area is located along Interstate 90, near the town of Valley Springs, South Dakota. More specifically, the facility which is approximately 12 miles east of the Sioux Falls metropolitan area, and adjacent to the Minnesota border line. The rest area services westbound truck and passenger car traffic entering into South Dakota from Minnesota.

The rest area has direct access to and from Interstate 90 which is shared with the Port of Entry (POE) located south of the rest area. The rest area includes parking for passenger vehicles and trucks, a picnic area, and dump station. Trucks that park at the POE are required to walk to the visitor center to utilize the facilities. The POE facilities are reviewed in a separate report.

The purpose of this report is to summarize the condition of existing site components and building systems for the facility as a whole. The intent for this report is to define the general status of the existing facilities given their age and use.

The report has been divided into two general areas of focus. The first section includes a general overview of the facility design and operations. Architectural issues, including the general capacity of the facilities and current operations, are reviewed and compared to current facility standards (i.e., building codes, ADA, etc.).

The systems overview section covers the type and condition of the components that make up the facility, and includes a summary evaluation of the site and building infrastructure. The site infrastructure repairs/replacement review includes sidewalks, lighting, signage, landscaping, and picnic shelters. The building systems infrastructure review includes items such as the building shell and structure, mechanical and plumbing systems, electrical, interior finishes, and communications/IT equipment.



II. GENERAL OVERVIEW

A. Rest Area Layout

The developed portion of the site is narrow and long running east to west paralleling the parking lot. The main facility is centrally located on the higher end of the properties. To the east and west are the walking paths and picnic areas. Roughly 500' to the north east are two sewage ponds supporting the facility.

Outdoor facilities include:

- One 24'x20' framed storage garage
- Four dual brick picnic shelters (2 tables ea.) approx. 19'x29'
- One 20'x50' area under main building structure
- Exterior visitor display structure
- Exterior uncovered vending machines and advertising equipment
- Two 3'x8' concrete benches
- Large lodge pole teepee structure
- Six integral reinforced concrete tables/bench sets on concrete slabs are placed throughout the site
- Six precast backless benches on steel posts
- Dumping station
- Flag pole

Utilities Include:

- Well and rural rater systems including an underground tank and pump to pressurize the system
- Gravity sewer system with lagoons (2)
- No city gas or propane tanks
- Electric power and transformer
- Telephone service

The facility in general consists of a 4,005 square foot canopy structure (plus 5' overhang), with an enclosed 1,333 square foot rest area within it. The facility includes:

- Lobby, and secured visitor center
- Men's and women's restrooms
- Mechanical, maintenance and storage area

Building Systems include:

- Heating and cooling including radiant electric panels and room air conditioners
- Exhaust only ventilation with no outside air
- Power is single phase, 120/240 volt, 225 amp

Figure 1 shows the layout of the Valley Springs Westbound Rest Area facility including the rest area's location in relation to major roadways in the area.



REST AREA KEY MAP

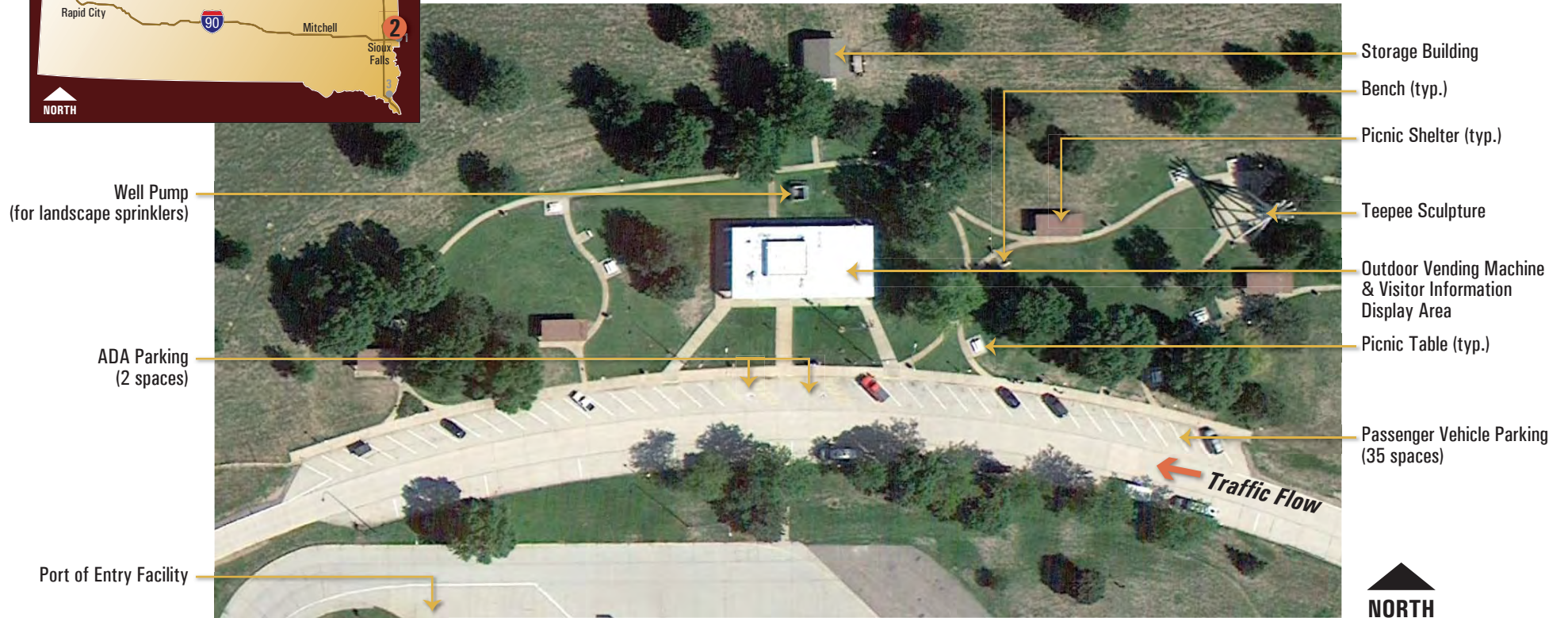


Figure 1. Valley Springs Rest Area Site Layout



B. Field Visit Observations

A field meeting was held with TSP and SDDOT officials on September 18, 2013 to gain initial insights from the SDDOT maintenance team about the operation, history, and condition of the existing on-site facilities at the Valley Springs Rest Area. A copy of the meeting minutes are contained in **Appendix A** in this report, the following summarizes the key points of the meeting:

- The facility was designed and constructed in 1973 with minimal changes or upgrades to meet current industry standards (ADA requirements, building codes).
- The facility appears to have been expanded at front and back sides of the lobby where the recessed glass areas were moved outward further to the building face.
- The facility was designed to be seasonally used, does not appear to have been winterized, is not insulated, and has limited mechanical systems.
- Operationally, a main issue with the site concerns the confusion created by the shared access with the POE for trucks, and the lack of overflow parking space for campers in peak tourist season.
- The Information lobby area is very small, with minimal circulation area and clearances.
- There is no dedicated storage space within the tourist information center where items can be stored – as such, in any available maintenance area (or chase) material is stored. Winter and bulk storage has been provided for in the constructed garage added a few years ago.
- ADA requirements for this facility have not been addressed. Each restroom includes three sinks. The men’s restroom has three stalls and three urinals, while the women’s restroom has five stalls. In general, the restrooms are very small with little space for circulation.
- ADA modifications have the potential impact entrances or loss of one stall and sink in each restroom.

C. User Environment

Architecturally, the facility is inviting, thoughtfully designed, and a clean modernist style. The exposed white concrete structural frame and flat roof gives form and scale the structure, while providing space for outdoor information display and vending equipment. The smaller information/toilet structure is placed under the canopy, and skinned with a vibrant red glazed brick. The entrance to the information center is glazed front and back to make space inviting, and to enhance natural daylight.

The facility was designed by Ward Whitwam, AIA a prominent State of SD Architect, as a sculptured modernist form. The design remains fresh, appropriate, and substantial. Unfortunately, the property is set back behind the “POE” which is utilitarian and dated.



The site is very lush, spacious, quiet and inviting. The lodge pole teepee structure can be seen from I-29, originally intended to attract visitors to the rest area. The structure is not an organizing element on the site, nor is anything more provided concerning a further message or function associated with South Dakota history.

D. Existing Building Code Conformity

The current facilities were designed and constructed in 1973 to the codes at the time, which lacked consideration for people with disabilities. To quantify the differences in code standards, the existing main building was evaluated per the ICC 2012 International Building Code which has been adopted by the State of South Dakota. Based on the use of the existing facility, the following building classifications were utilized in the comparison:

- Size: 5,408 square feet (size of canopy)
- Occupant Type: Mercantile
- Construction Type: Type 2-b (or 2-a)
- Occupant Load: < 50
- Maximum access travel: 75 feet
- Required Exits: 1

The following outline the major areas where the existing building deviates from the requirements of the current Building Code (IBC 2012):

- GFI power outlets are not present in restrooms, and the information desk requires additional power outlet boxes
- Ventilation system is required
- Facility does not include a family / assisted-use restroom
- Several areas are not ADA compliant per ICC A117.1-2009 (outlined in following sections)
- Storage placed around some electrical panels does not meet 36" minimum clearance

It should be noted that per the "Existing" Building Code, unless there are significant safety hazards, the facilities are not required to be modernized as a whole to meet current code standards. However, any repairs or new additions will need to be completed to these standards. The exception concerns ADA requirements, which are a retroactive federal requirement. When the ADA is addressed the project will need to also be completed per building code, which includes accessibility criteria (ICC- A117.1-2009).

E. Americans with Disabilities Act (ADA) Survey

The building was originally constructed prior to the ADA, and it has not been updated meet current standards. To quantify the improvements required to the current facility for compliance with ADA standards, a detailed survey was completed utilizing the "ADA Checklist for Readily Achievable Barrier Removal" per the DOJ ADA Standards for Accessible Design - 2010. The survey identified the following general deficiencies, and more detailed information is referenced in **Appendix B** of this report:



Priority 1 Deficiencies (access to building):

- Accessible parking spaces at the front of the building do not meet maximum slope limitations
- Parking signs do not meet current MUTCD standards
- Access aisle is not striped
- Accessible route to front door is steeper than 5%
- ADA pull handle on entrance door has insufficient clearance
- Door closer takes less than 5 seconds to close from an open position

Priority 2 Deficiencies (Access to Goods and Services):

- Doorways from the lobby to each of the restrooms do not have sufficient corridor width
- There is insufficient ADA clearance with the existing 36" wide corridor when using operable restroom entrance doors (46-52"min.required depending upon configuration)
- Information Area:
 - Area behind counter and information desks / map count height do not meet ADA clearance or height standards
 - There is a section of counter that is higher than 36 inches above the floor.
 - Signage, upgrade existing signs to current ADA standards
- Only one of twelve exterior picnic benches has been modified to current ADA standards

Priority 3 (Restrooms):

- Stall doors not self- closing
- The sign on the wall, located on the push side of the door does not meet ADA standards
- There is not adequate clearance on the pull side of the door
- The door hardware is not located in compliance with ADA standards
- The door cannot be opened with 5 lbs. or less of force
- The door does not take more than five seconds to close from an open position
- The front of the lavatory counter is more than 34 inches above the floor
- Pipes below the lavatories are not insulated or covered
- Soap dispensers above the lavatory counter are more than 44 inches above the floor
- Men's and women's toilet is more than 18 inches from the side wall or partition
- Men's and women's toilet does not have adequate clearance to meet ADA standards.
- Grab bars do not meet ADA standards
- Toilet paper holders in men's and women's stalls do not meet standards
- Entrance doors to stalls do not meet closure pressure or ADA pull handle standards
- Toilet compartment is less than 60 inches wide



Priority 4 (additional access) Deficiencies:

- Phone is wall mounted and does not meet ADA standards for sound control, TTY plug in, and shelf.

F. Energy and Water Usage Review

TSP has not received any data concerning this information:



III. BUILDING SYSTEM OVERVIEW

The following sections include a general review of individual building and site components, starting with site components and then broken down by individual disciplines (Architectural Systems, Mechanical, Electrical, Plumbing, and Civil/Site systems). The discussion generally parallels SDDOT AuditMate database format.

A detailed summary of each discipline section in the current AuditMate format including general comments of individual line items are contained in **Appendix C** of this report. The table contains both existing line items and recommended updates to the SDDOT database, which are shown in **bold** font.

A. Architectural System

The original structure was constructed in 1973 to service travelers in the summer months. There has been minor upgrades including expansion of the information area of the lobby, adding low cost electric heat for year round operations, and unit air conditioners. The building has not been insulated for year round use.

The building structure includes a reinforced two-way poured in place concrete structural system, with a membrane roof on insulation board. The exterior and interior walls are masonry on foundations, and both are in excellent condition requiring only a few minor repairs.

The exposed and painted underside of the roof structure is nine feet above the ground, except at the lobby where a section of it is raised approximately 10'-6" above the floor. These clearances are limited and make it difficult to provide for modern ventilation ductwork and lighting systems.

B. Plumbing System

All plumbing fixtures installed in 1973 are vitreous china including wall hung water closets and urinals, and countertop lavatory sinks. Lavatories faucets and water closets flush valves are electronic type; battery operated, and were installed roughly between 2005 to 2008. The electric water cooler is wall hung and was installed in 2006. There is water bottle filler inside the building.

Waste and vent piping is cast iron and original (1973). Water piping is copper and was also installed in 1973. Water piping insulation is partially original fabric covered pipe insulation and partially closed cell foam insulation. Roof drain piping is copper, installed in 1973, and is partially insulated with original fabric covered pipe insulation.

Water for domestic use is supplied by a rural water system. The system has a water pressure regulator, water meter, and backflow preventer. The system supplies all plumbing fixtures in the building. The domestic water is heated with an electric water heater located in the basement that was installed in 1994.

Water for the lawn irrigation system is supplied from a shallow well and pumped to a 6,000 gallon underground fiberglass holding tank. Water is pumped from the storage tank, into the building, and out to the lawn irrigation system, by a water pressure booster system. The water



system that supplies the lawn irrigation system was installed in 1993 and some components have been replaced over time.

C. Mechanical System

The building is heated by electric radiant panels in the lobby and toilet rooms and with electric unit heaters in the equipment / storage rooms. Lobby and toilet rooms are cooled with residential type window air conditioners. The radiant panels, unit heaters and window air conditioners do not provide any outside air for ventilation.

Exhaust ventilation for each of the toilet rooms is ducted to small utility fan set that was installed in 1993. Exhaust grilles are wall mounted on the water closet wall in each toilet room. The fan sets have been disconnected and abandoned, leaving no operable exhaust ventilation systems in the building.

D. Electrical System

The building is served by a one phase 240 volt, 225 amp service. There are two 225 amp panels located the mechanical room, and are clearly labeled as to what each beaker serves. All wiring is run in conduit, and panel boards appear to be original equipment (1993 installed).

All indoor lighting fixtures are original. All lamps are fluorescent, and lighting fixtures are a mix of recessed cans and indirect fluorescent in the main lobby, and ceiling mounted fixtures in the restrooms and equipment rooms.

Outdoor lighting is primarily high pressure sodium or HID. Recessed and surface mounted fixtures are used on the building. Some fixtures had signs of moisture, indicating the lens is no longer sealing properly. Outdoor lighting fixtures vary in age, from original (1993) to recent replacements in 2005.

Hand dryers are electric and operating properly.

CCTV is installed in the lobby. There is also an emergency beacon system, the operation of which was not immediately observable, but confirmed by staff.

E. Sanitary Sewer System

The sanitary sewer system consists of gravity flow sewer lines to two sewage lagoons located at the northeast corner of the site. Each pond is approximately the same size, with the southern pond serving as overflow for the north pond. Maintenance personal suspect both ponds are leaking, and are scheduled for re-lining and riprap work in the near future. Capacity of the ponds is not known due to their leaking, but the piping system is adequate and has not caused any problems historically.

F. Water System

Water is supplied by rural water. There is a well in the rear of the building that is used for irrigation. The irrigation system leaks and requires regular maintenance.



G. Infrastructure

The parking area is concrete with some asphalt shoulders along the ramps. The general condition of the concrete is good for the ramps and parking area, with most of the deterioration being in the joints. There is one longitudinal crack that bisects the parking spaces for nearly the entire length of the lot. Joint repair and sealing should be done soon to extend the life of the pavement another 15 years to a life span of 60 years.

Asphalt pavement is used for shoulders along the ramps. This asphalt should have major cracks sealed and have a seal coat applied to extend the life of the asphalt. Maintenance should include spraying of grass or weeds that appear in cracks.

Concrete walk extends along the parking spaces, around the building, and to picnic shelters around the site. The majority of the concrete sidewalk is in good shape, and estimate that 10% of the sidewalk has cracks that will warrant replacement in the future. Portions of the walk surrounding the teepee and around the main building may need to be replaced.



IV. SUMMARY

The Valley Springs Westbound Rest Area is located along Interstate 90 supporting westbound traffic. More specifically, the site is adjacent to the Minnesota border approximately 12 miles east of the Sioux Falls, South Dakota metropolitan area.

The rest area has direct access to and from Interstate 90 which is shared with the Port of Entry (POE) facility located south of the rest area. The rest area includes parking for passenger vehicles and campers, and trucks must park at the POE and walk to the visitor center to utilize the facilities.

The purpose of this report was to summarize the condition of existing site components and building systems for the facility as a whole, and to define the general status of the existing facilities given their age and use.

As the main building structure was built in 1973 and the systems as a whole are nearing the end of their design life. There will be an increasing need in the years ahead for repairs and reconstruction including upgrades to the mechanical, power and lighting systems, as well as to general interior finishes, doors, windows, and equipment. The facility will need to be modified to comply with ADA/building code requirements. The extent of which has yet to be determined, as an additional factor will be in identifying the added space required to modify the restroom entrances, to support increased user loads (if any), and to provide family assist restroom(s).

The site is substantial with area to expand and make changes. Several deficiencies have been identified requiring future consideration including shared access with the POE, ADA compliance and the appropriateness of the lodge pole/TeePee sculptural element.



The Interstate Rest Areas Study: Along the I-29 and I-90 Corridors

APPENDIX A MAINTENANCE STAFF MEETING MINUTES



October 15, 2013

MEETING MINUTES

SDDOT INTERSTATE REST AREA STUDY

FHU Reference No. 113039-01

Valley Springs Maintenance Review Meeting
Valley Springs Rest Area

Date of Meeting: September 18, 2013

In attendance:

- Brad Remmich – SDDOT
- Keith Voegeli – SDDOT
- Jeff Gustafson - SDDOT
- Tim Roach – TSP
- Bob King – TSP
- Todd Schultz - TSP

The purpose of the meeting was to gain initial insights from the SDDOT maintenance team about the operation, history, and condition of the existing on-site facilities at the Valley Springs rest area. The following summarizes the key points of the meeting:

FACILITY USE

- There is a consistent year round use of the facilities by truckers, and local commuters. In the summer, there is a notably a large increase in tourist use. The facility only overflows during the Sturgis rally week.
- The properties are shared with the neighboring SDDOT port of entry (POE) which has consistent flow of truckers all year. To use the facilities, truckers typically walk about 100 yards over from the adjacent POE (as no facilities are provided for them there). Truckers often overnight at the POE when the weather sours or the roads are closed.
- The facility houses a full time manned tourist center which is in operation in the summer months (roughly June – September). It was in operation while we were present. From the attendants we learned that at peak times 500-700 sign-in's per day (during the Sturgis Rally), but it is heavily used all season. It appears that the space was enlarged slightly within the structure some time ago however the space is still too small. When the displays are up, there is no space for waiting - it appears, from the visitor attendant's perspective, as if more display and circulation space is sorely needed.
- The structure itself seems to be limited in interior space for both the restrooms and the visitor's area. The restrooms comfortably support perhaps 3-4 people at a time, but there is little maneuvering space.
- The picnic shelters are heavily used most of the summer months (June – August).

October 15, 2013

Valley Springs Maintenance Review Meeting

Page 2

- A separate storage garage was fairly recently built behind the building for maintenance equipment, and for tourist information storage which appears to be sufficient.
- Camper parking at the rest area stop is limited and undersized at times, and there is no access to the truck parking area when the lot is full. General parking seems adequate all year round, including the rally.
- Based on SDDOT information, with the exception of the Sturgis Rally, the building seems to be sized appropriately for travelers except for the information area which is undersized, more information and counter space is needed, and space for short term storage of brochures.

USER INFORMATION

- There are a balanced proportion of general travelers and tourists at this location. The dumping station is heavily used. There is also higher trucker use due to the presence of the adjacent POE.
- The neighboring POE is a busy location. Many of the truckers will overnight at the POE and it is a safe refuge in bad weather. (see POE report)

FACILITY NEEDS / ISSUES

- There have been some common complaints at this location
- As the site ramp entrance and exit is shared with the separate POE, Truck and Camper parking and access is confusing and is an issue which needs to be further reviewed and addressed (see POE report). The shared entrance ramp is unusual and unexpected, and not seen in most other states. This is a main cause for problems and complaints - truckers often bypass the POE unintentionally. Or, they often mistakenly enter the visitor center entrance and have no way to get back to the POE. They then require an escort to proceed forward on the highway, turn around and return.
- Given the age, condition, and limitations of the existing site and facilities, substantial reinvestment in this site will be required.
- Dual Men's entrance/women's entrance door to main lobby is confusing and awkward.
- Ventilation and better heating and Cooling are needed. There are no central heating, cooling, and ventilation systems in the building. Complaints on bathroom smells from the visitor center occupants.
- There is no immediate safety issues reported. A video monitor system is very successful in reducing vandalism and security problems. However the system, which can be remotely accessed, is old and only about half of the cameras are in working order.
- Neighboring POE provides a reassuring sense of safety for occupants and truckers. The staff at the visitor's information desk feels very safe as the facility is visible from the neighboring POE State Police office. They see a large benefit in sharing the site with the POE.
- There is no history of accidents related to current facility and on site circulation.
- Site Systems (landscaping, lighting, trash, ponds, etc.):

October 15, 2013

Valley Springs Maintenance Review Meeting

Page 3

- Sidewalk, stairs, and paving show signs of aging and wear, but otherwise surfaces are in good condition.
 - Lagoon System leaks and is being rebuilt at the time of this visit. They have had no problems with piping leaks.
 - There are two water systems – one supports the domestic water need for the facility which is rural water, the second is well water which supplies the lawn irrigation system. The lawn irrigation system and well housing will need replacement.
 - There are no gas lines or propane tanks – the building is heated with electric heat.
 - Site parking, pedestrian, and exterior building lighting systems are original and are becoming unruly and expensive to maintain. Need replacement ASAP.
 - Site drainage is excellent, and there isn't a history of ponding or flooding.
 - Dog walk area has heavy use, could use baggie stand to assist and encourage user pick up and disposal of dog waste.
 - Landscaping includes some very mature trees. Some of these sustained some damage in the ice storm of Spring, 2013 and may need to be replaced in the future.
- Building Systems (shell, interior finishes, MEP):
 - Upgrade to ADA Requirements.
 - Replace video camera system.
 - Replace plumbing fixture valves/sensors – they're failing all the time at this location. DOT maintenance personnel do not want automatic sensors at all.
 - Ongoing roof leaks in main facility need final repair (5 years old but under warranty and not fixed).
 - Lawn irrigation system needs to be replaced.
 - Heat and Ventilation system replacement/modernization is past due.
 - Electrical power upgrades in support of the visitor station desk are needed.
 - Interior Lighting outdated and failing – maintenance cost and problems...needs replacement.
 - There is no bathroom exhaust (per code) - bathroom smells are distinct and noticeable most of the time.
 - Heating and ventilation are inadequate at this facility. There is no fresh air ventilation system in the building as the facility was originally designed as a one season non-insulated structure. Existing exhaust ventilation fan units have been shut down. Electric radiant panel heaters were later added, as were window mounted residential A/C units. There have been condensation problems on the underside of roof structure, and on windows. All interior spaces within can get chilled and damp.

SDDOT MAINTENANCE STAFF REQUESTS

- Address display space for the tourist information area and internal storage.
- Address need for additional recreational vehicle/motor home parking.

These meeting minutes were prepared by Tim Roach (TSP). Please contact me at roachtj@teamtsp.com or 605-343-6102 for corrections or clarifications.



The Interstate Rest Areas Study: Along the I-29 and I-90 Corridors

APPENDIX B ADA SURVEY RESULTS

SDDOT Rest Area Improvements
FHU Reference Number 13-039-01
TSP Project Number 03120855

Building **VALLEY SPRINGS**

Location **90 W., MRM 412**

Date **09-18-2013 (Inspection)**

ADA Checklist for Readily Achievable Barrier Removal

Priority 1 – Approach & Entrance



SDDOT Rest Area Improvements

FHU Reference Number 13-039-01

TSP Project Number 03120855

Project

Building **VALLEY SPRINGS**

Location **90 W., MRM 412**

Date **09-18-2013 (Inspection)**

Surveyors **Timothy Roach, AIA**
Todd Schultz, PE

Robert King, CPD

Contact Information **TSP (605) 343-6102**

An accessible route from site arrival points and an accessible entrance should be provided for everyone.



Institute for Human Centered Design
www.HumanCenteredDesign.org

November 2011

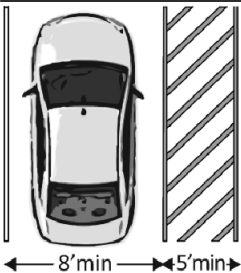


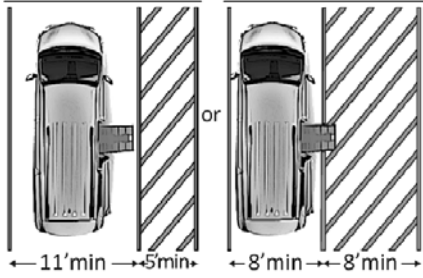
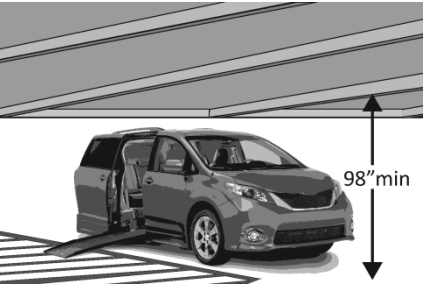
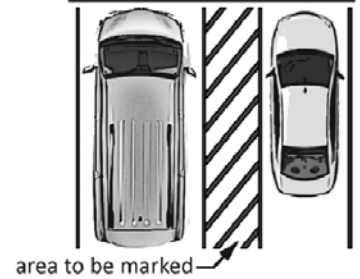
ADA National Network
Questions on the ADA 800-949-4232 voice/tty
www.ADAchecklist.org


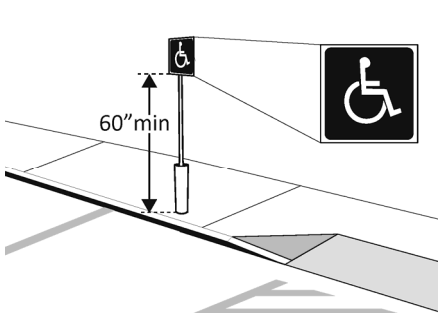
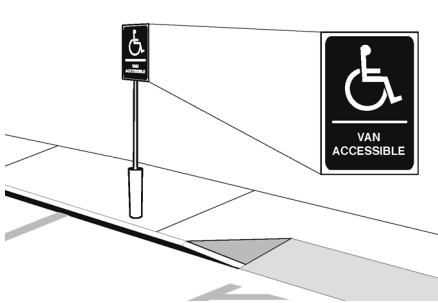

This checklist was produced by the New England ADA Center, a project of the Institute for Human Centered Design and a member of the ADA National Network. This checklist was developed under a grant from the Department of Education, NIDRR grant number H133A060092-09A. However the contents do not necessarily represent the policy of the Department of Education, and you should not assume endorsement by the Federal Government.

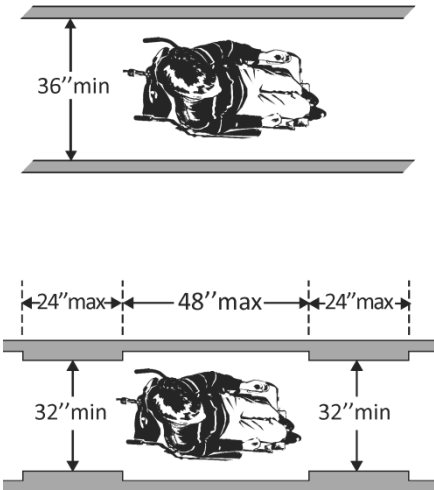
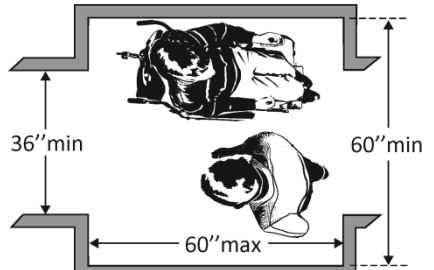
Questions or comments on the checklist contact the New England ADA Center at 617-695-0085 voice/tty or ADAinfo@NewEnglandADA.org

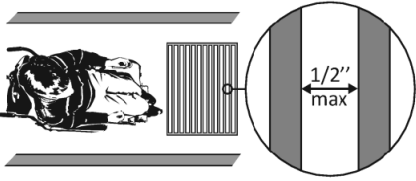
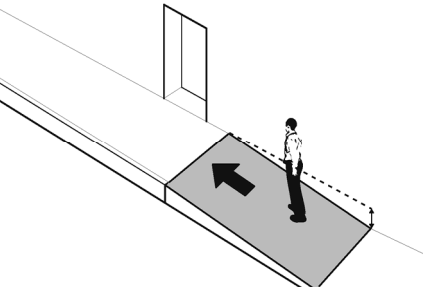
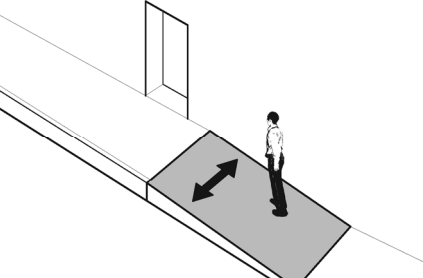
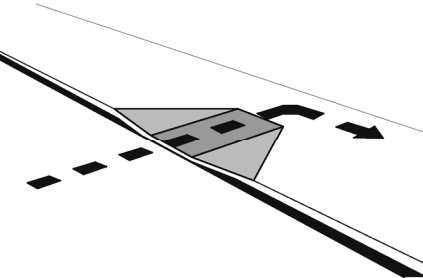
For the full set of checklists, including the checklists for recreation facilities visit www.ADAchecklist.org.

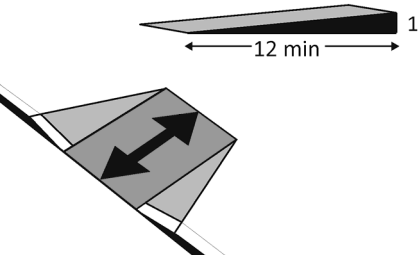
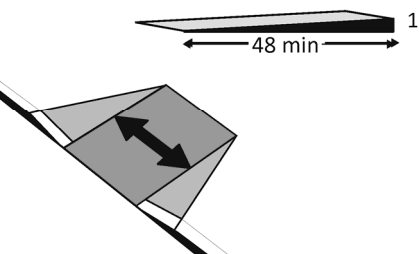
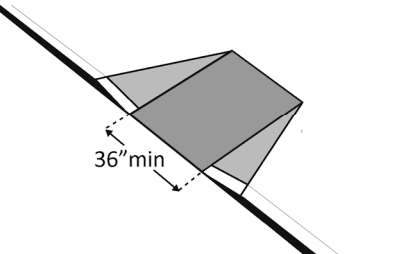
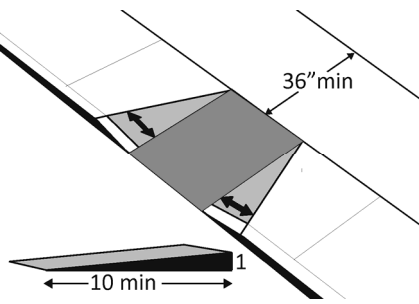
Priority 1 – Approach & Entrance		Comments	Possible Solutions												
<p>1.1 Is there at least one route from site arrival points (parking, passenger loading zones, public sidewalks and public transportation stops) that does not require the use of stairs?</p>	<p><input checked="" type="checkbox"/> Yes <input type="checkbox"/> No</p> <p>If yes, location of route:</p>	<p>Photo #: 1.1</p>	<ul style="list-style-type: none"> • Add a ramp • Regrade to 1:20 maximum slope • Add a lift if site constraints prevent other solutions 												
<p>Parking (2010 Standards – 208 & 502) Note: Accessible parking spaces should be identified by size, access aisle and signage.</p>															
<p>1.2 If parking is provided for the public, are an adequate number of accessible spaces provided?</p>	<p><input checked="" type="checkbox"/> Yes <input type="checkbox"/> No</p> <p>Total #: 47</p> <p>Accessible #: 2</p>	<table border="1"> <thead> <tr> <th>Total Spaces</th> <th>Accessible Spaces</th> </tr> </thead> <tbody> <tr> <td>1 - 25</td> <td>1</td> </tr> <tr> <td>26 - 50</td> <td>2</td> </tr> <tr> <td>51 - 75</td> <td>3</td> </tr> <tr> <td>76 - 100</td> <td>4</td> </tr> <tr> <td colspan="2">100+ see 2010 Standards 208.2</td> </tr> </tbody> </table> <p>The 47 parking spaces include RV parking spaces.</p> <p>Photo #: 1.2</p>	Total Spaces	Accessible Spaces	1 - 25	1	26 - 50	2	51 - 75	3	76 - 100	4	100+ see 2010 Standards 208.2		<ul style="list-style-type: none"> • Reconfigure by repainting lines • •
Total Spaces	Accessible Spaces														
1 - 25	1														
26 - 50	2														
51 - 75	3														
76 - 100	4														
100+ see 2010 Standards 208.2															
<p>1.3 Of the accessible spaces, is at least one a van accessible space?*</p>	<p><input checked="" type="checkbox"/> Yes <input type="checkbox"/> No</p>	<p>*For every 6 or fraction of 6 parking spaces required by the table above, at least 1 should be a van accessible space.</p> <p>Photo #: 1.3</p>	<p>* If constructed before 3/15/2012, parking is compliant if at least 1 in every 8 accessible spaces is van accessible</p> <ul style="list-style-type: none"> • Reconfigure by repainting lines 												
<p>1.4 Are accessible spaces at least 8 feet wide with an access aisle at least 5 feet wide?</p>	<p><input checked="" type="checkbox"/> Yes <input type="checkbox"/> No</p> <p>Measurement:</p>	 <p>11 ft Space 5 ft Aisle</p> <p>Photo #:</p>	<ul style="list-style-type: none"> • Reconfigure by repainting lines <p>Two spaces can share an access aisle (check state requirements; some states, such as Connecticut, require an access aisle for</p>												

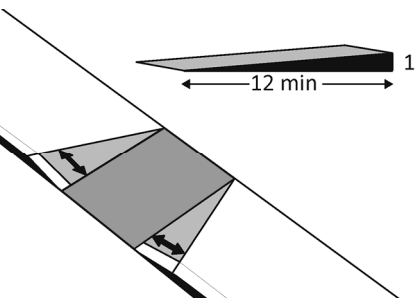
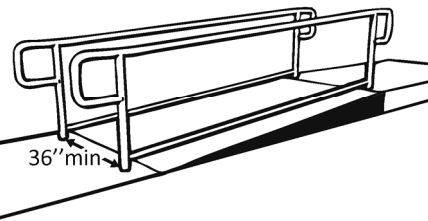
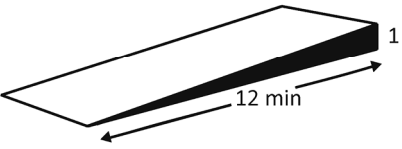
<p>1.5 Is the van accessible space: At least 11 feet wide with an access aisle at least 5 feet wide? Or At least 8 feet wide with an access aisle at least 8 feet wide?</p>	<p><input checked="" type="checkbox"/> Yes <input type="checkbox"/> No Measurement: 11 feet <input checked="" type="checkbox"/> Yes <input type="checkbox"/> No Measurement: 5 feet</p>		<p>Photo #: 1.5</p>	<p>each space)</p> <ul style="list-style-type: none"> • Reconfigure to provide van-accessible space(s) • •
<p>1.6 Is at least 98 inches of vertical clearance provided for the van accessible space?</p>	<p><input checked="" type="checkbox"/> Yes <input type="checkbox"/> No Measurement:</p>		<p>No Roof Photo #:</p>	<ul style="list-style-type: none"> • Reconfigure to provide van-accessible space(s) • •
<p>1.7 Are the access aisles marked so as to discourage parking in them?</p>	<p><input checked="" type="checkbox"/> Yes <input type="checkbox"/> No</p>		<p>Photo #: 1.7</p>	<ul style="list-style-type: none"> • Mark access aisles • • <p>The marking method and color may be addressed by state/local requirements</p>
<p>1.8 Is the slope of the accessible parking spaces and access aisles no steeper than 1:48 in all directions?</p>	<p><input type="checkbox"/> Yes <input checked="" type="checkbox"/> No Measurement: 2.8% - 2.9% 1:36 – 1:35</p>		<p>Photo #: 1.8.1 & 1.8.2</p>	<ul style="list-style-type: none"> • Regrade surface • •

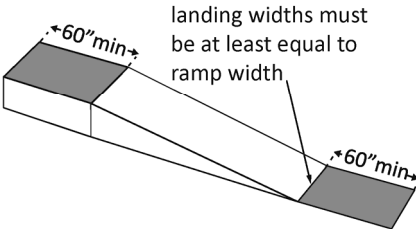
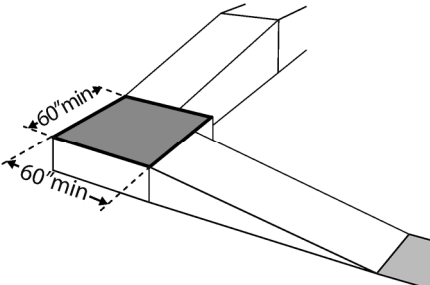
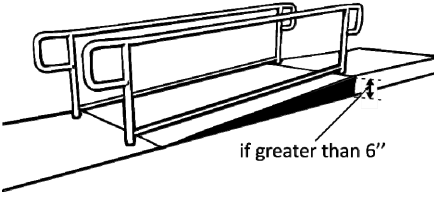
<p>1.9 Do the access aisles adjoin an accessible route?</p>	<p><input checked="" type="checkbox"/> Yes <input type="checkbox"/> No</p>		<p>Photo #: 1.9</p>	<ul style="list-style-type: none"> • Create accessible route • Relocate accessible space •
<p>1.10 Are accessible spaces Identified with a sign that includes the International Symbol of Accessibility?</p> <p>Is the bottom of the sign at least 60 inches above the ground?</p>	<p><input checked="" type="checkbox"/> Yes <input type="checkbox"/> No</p> <p><input checked="" type="checkbox"/> Yes <input type="checkbox"/> No</p> <p>Measurement: 60"</p>		<p>Photo #: 1.10</p>	<ul style="list-style-type: none"> • Install signs • • <p>The International Symbol of Accessibility is not required on the ground by the 2010 Standards</p>
<p>1.11 Are there signs reading “van accessible” at van accessible spaces?</p>	<p><input checked="" type="checkbox"/> Yes <input type="checkbox"/> No</p>		<p>Photo #: 1.10</p>	<ul style="list-style-type: none"> • Install signs • •
<p>1.12 Of the total parking spaces, are the accessible spaces located on the closest accessible route to the accessible entrance(s)?</p>	<p><input checked="" type="checkbox"/> Yes <input type="checkbox"/> No</p>		<p>Photo #: 1.12</p>	<ul style="list-style-type: none"> • Reconfigure spaces • • <p>If parking lot serves multiple entrances, accessible parking should be dispersed</p>

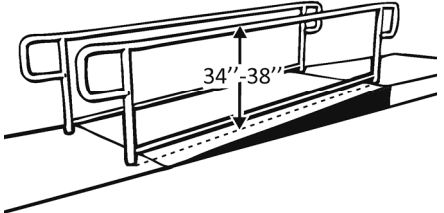
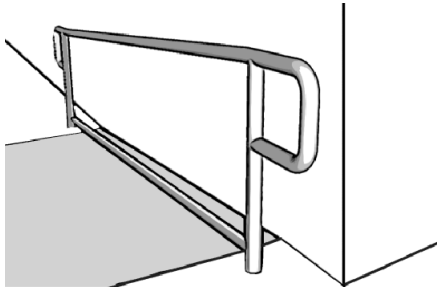
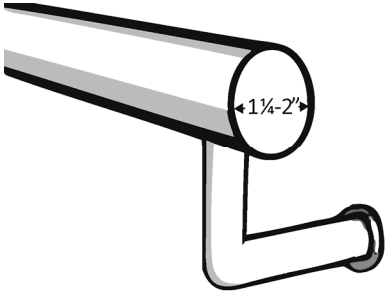
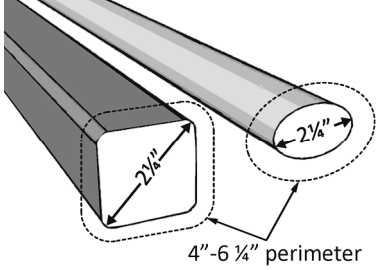
Exterior Accessible Route (2010 Standards – Ch.4)				
<p>1.13 Is the route stable, firm and slip-resistant?</p>	<p><input checked="" type="checkbox"/> Yes <input type="checkbox"/> No</p>		<p>Photo #: 1.13</p>	<ul style="list-style-type: none"> • Repair uneven paving • Fill small bumps and breaks with patches • Replace gravel with asphalt or other surface
<p>1.14 Is the route at least 36 inches wide?</p> <p>Note: The accessible route can narrow to 32 inches min. for a max. of 24 inches. These narrower portions of the route must be at least 48 inches from each other.</p>	<p><input checked="" type="checkbox"/> Yes <input type="checkbox"/> No</p> <p>Measurement:</p>		<p>Photo #: 1.13</p>	<ul style="list-style-type: none"> • Change or move landscaping, furnishings or other items • Widen route •
<p>1.15 If the route is greater than 200 feet in length and no less than 60 inches wide, is there a passing space no less than 60 x 60 inches?</p>	<p><input type="checkbox"/> Yes <input type="checkbox"/> No</p> <p>Measurement: NA</p>		<p>Photo #:</p>	<ul style="list-style-type: none"> • Widen route for passing space • •

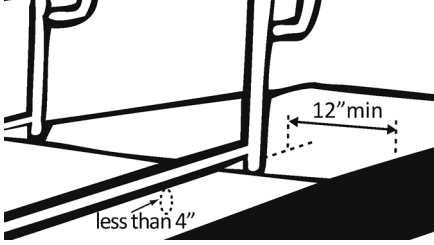
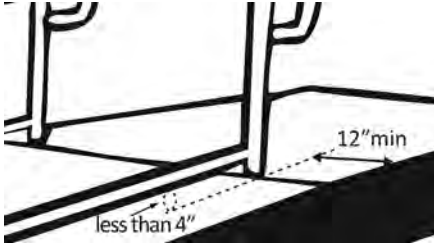
<p>1.16 If there are grates or openings on the route, are the openings no larger than ½ inches to the dominant direction of travel?</p> <p>Is the long dimension perpendicular to the dominant direction of travel?</p>	<p><input type="checkbox"/> Yes <input type="checkbox"/> No</p> <p>Measurement:</p> <p><input type="checkbox"/> Yes <input type="checkbox"/> No</p> <p>NA</p>		<p>Photo #:</p>	<ul style="list-style-type: none"> • Replace or move grate • •
<p>1.17 Is the running slope no steeper than 1:20, i.e. for every inch of height change there are at least 20 inches of route run?</p>	<p><input type="checkbox"/> Yes <input checked="" type="checkbox"/> No</p> <p>Measurement:</p> <p>5.9%</p> <p>1:17</p>		<p>Photo #: 1.17</p>	<ul style="list-style-type: none"> • Regrade to 1:20 max. • If steeper than 1:20 and no steeper than 1:12, treat as a ramp and add other features such as edge protection and handrails •
<p>1.18 Is the cross slope no steeper than 1:48?</p>	<p><input checked="" type="checkbox"/> Yes <input type="checkbox"/> No</p> <p>Measurement:</p> <p><2%</p>		<p>Photo #:</p>	<ul style="list-style-type: none"> • Regrade to 1:48 max. • •
<p>Curb Ramps (2010 Standards – 406)</p>				
<p>1.19 If the accessible route crosses a curb, is there a curb ramp?</p>	<p><input checked="" type="checkbox"/> Yes <input type="checkbox"/> No</p>		<p>Photo #: 1.19</p>	<ul style="list-style-type: none"> • Install curb ramp • •


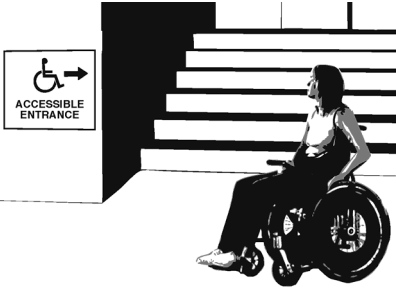

<p>1.20 Is the running slope of the curb ramp no steeper than 1:12, i.e. for every inch of height change there are at least 12 inches of curb ramp run?</p>	<p><input checked="" type="checkbox"/> Yes <input type="checkbox"/> No</p> <p>Measurement: <1:12</p>		<p>Photo #:</p>	<ul style="list-style-type: none"> • Regrade curb ramp • •
<p>1.21 Is the cross slope of the curb ramp, excluding flares, no steeper than 1:48?</p>	<p><input checked="" type="checkbox"/> Yes <input type="checkbox"/> No</p> <p>Measurement: <1:48</p>		<p>Photo #:</p>	<ul style="list-style-type: none"> • Regrade curb ramp • •
<p>1.22 Is the curb ramp, excluding flares, at least 36 inches wide?</p>	<p><input checked="" type="checkbox"/> Yes <input type="checkbox"/> No</p> <p>Measurement: >36"</p>		<p>Photo #:</p>	<ul style="list-style-type: none"> • Widen curb ramp • •
<p>1.23 At the top of the curb ramp is there a level landing (slope no steeper than 1:48 in all directions) that is at least 36 inches long and at least as wide as the curb ramp? If there are curb ramp flares, are the slopes of the flares no steeper than 1:10, i.e. for every inch of height change there are at least 10 inches of flare run?</p>	<p><input type="checkbox"/> Yes <input checked="" type="checkbox"/> No</p> <p>Measurement: >1:48 SEE 1.17</p> <p><input type="checkbox"/> Yes <input type="checkbox"/> No NA</p> <p>Measurement:</p>		<p>Photo #:</p>	<ul style="list-style-type: none"> • Reconfigure • Add ramp flares •

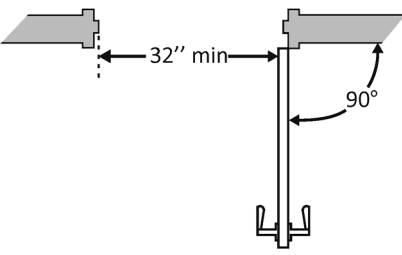
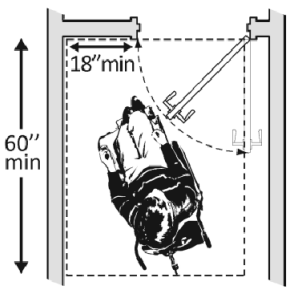
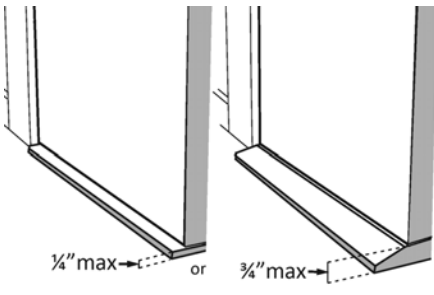
<p>1.24 If the landing at the top is less than 36 inches long, are there curb ramp flares?</p> <p>Are the slopes of the flares no greater than 1:12, i.e. for every inch of height change there are at least 12 inches of flare run?</p>	<p><input checked="" type="checkbox"/> Yes <input type="checkbox"/> No</p> <p><input checked="" type="checkbox"/> Yes <input type="checkbox"/> No</p> <p>Measurement: <1:12</p>		<p>Photo #:</p>	<ul style="list-style-type: none"> • Add ramp flares • Regrade flares •
<p>Ramps (2010 Standards – 405 & 505) Note: If any portion of the accessible route is steeper than 1:20, it should be treated as a ramp.</p>				
<p>1.25 If there is a ramp (other than curb ramps), is it at least 36 inches wide? If there are handrails, measure between the handrails.</p>	<p><input type="checkbox"/> Yes <input type="checkbox"/> No</p> <p>Measurement: NA</p>		<p>Photo #:</p>	<ul style="list-style-type: none"> • Alter ramp • •
<p>1.26 Is the surface stable, firm and slip resistant?</p>	<p><input type="checkbox"/> Yes <input type="checkbox"/> No</p> <p>NA</p>		<p>Photo #:</p>	<ul style="list-style-type: none"> • Resurface ramp • •
<p>1.27 For each section of the ramp, is the running slope no greater than 1:12, i.e. for every inch of height change there are at least 12 inches of ramp run?</p> <p>Note: Rises no greater than 3 inches with a slope no steeper than 1:8 and rises no greater than 6 inches with a slope no steeper</p>	<p><input type="checkbox"/> Yes <input type="checkbox"/> No</p> <p>Measurement: NA</p>		<p>Photo #:</p>	<ul style="list-style-type: none"> • Alter or relocate ramp • Lengthen ramp to decrease slope •

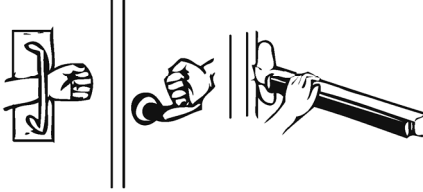
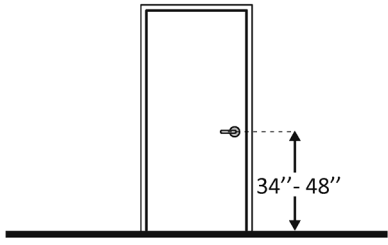
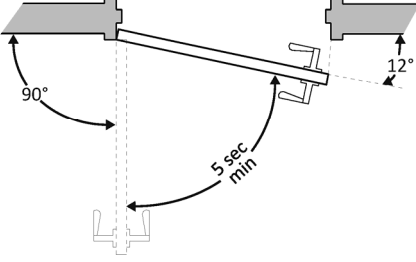
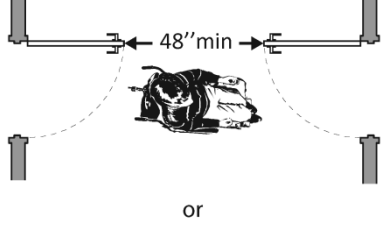
<p>than 1:10 are permitted when such slopes are necessary due to space limitations.</p>			<p>Photo #:</p>	
<p>1.28 Is there a level landing that is at least 60 inches long and at least as wide as the ramp:</p> <p>At the top of the ramp?</p> <p>At the bottom of the ramp?</p>	<p><input type="checkbox"/> Yes <input type="checkbox"/> No</p> <p>Measurement:</p> <p><input type="checkbox"/> Yes <input type="checkbox"/> No</p> <p>Measurement:</p>		<p>NA</p> <p>Photo #:</p>	<ul style="list-style-type: none"> • Alter ramp • •
<p>1.29 Is there a level landing where the ramp changes direction that is at least 60 x 60 inches?</p>	<p><input type="checkbox"/> Yes <input type="checkbox"/> No</p> <p>Measurement:</p>		<p>NA</p> <p>Photo #:</p>	<ul style="list-style-type: none"> • Alter ramp • •
<p>1.30 If the ramp has a rise higher than 6 inches, are there handrails on both sides?</p>	<p><input type="checkbox"/> Yes <input type="checkbox"/> No</p> <p>Measurement:</p>		<p>NA</p> <p>Photo #:</p>	<ul style="list-style-type: none"> • Add handrails • • <p>Curb ramps are not required to have handrails</p>

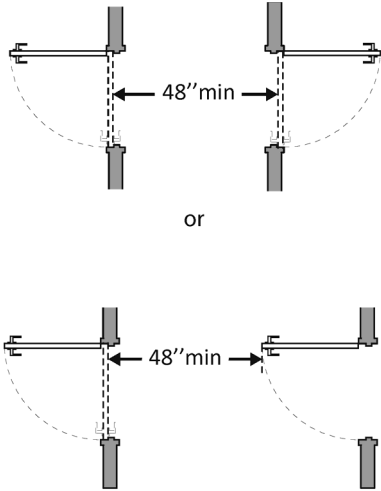

<p>1.31 Is the top of the handrail gripping surface no less than 34 inches and no greater than 38 inches above the ramp surface?</p> <p><input type="checkbox"/> Yes <input type="checkbox"/> No</p> <p>Measurement:</p>		<p style="text-align: center;">NA</p> <p>Photo #:</p>	<ul style="list-style-type: none"> • Reconfigure or replace handrails • •
<p>1.32 Is the handrail gripping surface continuous and not obstructed along the top or sides?</p> <p>Is the bottom of the handrail gripping surface obstructed for no more than 20 percent of its length?</p> <p><input type="checkbox"/> Yes <input type="checkbox"/> No</p> <p><input type="checkbox"/> Yes <input type="checkbox"/> No</p> <p>Measurement:</p>		<p style="text-align: center;">NA</p> <p>Photo #:</p>	<ul style="list-style-type: none"> • Reconfigure or replace handrails • •
<p>1.33 If the handrail gripping surface is circular, is it no less than 1 ¼ inches and no greater than 2 inches in diameter?</p> <p><input type="checkbox"/> Yes <input type="checkbox"/> No</p> <p>Measurement:</p>		<p style="text-align: center;">NA</p> <p>Photo #:</p>	<ul style="list-style-type: none"> • Replace handrails • •
<p>1.34 If the handrail gripping surface is non-circular, is it no less than 4 inches and no greater than 6 ½ inches in perimeter and no more than 2 ¼ inches in cross section?</p> <p><input type="checkbox"/> Yes <input type="checkbox"/> No</p> <p>Measurement:</p>		<p style="text-align: center;">NA</p> <p>Photo #:</p>	<ul style="list-style-type: none"> • Replace handrails • •

<p>1.35 Does the handrail:</p> <p>Extend at least 12 inches horizontally beyond the top and bottom of the ramp?</p> <p>Return to a wall, guard, or landing surface?</p>	<p><input type="checkbox"/> Yes <input type="checkbox"/> No</p> <p>Measurement:</p> <p><input type="checkbox"/> Yes <input type="checkbox"/> No</p>		<p style="text-align: center; color: red;">NA</p> <p>Photo #:</p>	<ul style="list-style-type: none"> • Add extensions • Reconfigure handrails •
<p>1.36 To prevent wheelchair casters and crutch tips from falling off:</p> <p>Does the surface of the ramp extend at least 12 inches beyond the inside face of the handrail?</p> <p>Or</p> <p>Is there a curb or barrier that prevents the passage of a 4-inch diameter sphere?</p>	<p><input type="checkbox"/> Yes <input type="checkbox"/> No</p> <p>Measurement:</p> <p><input type="checkbox"/> Yes <input type="checkbox"/> No</p> <p>Measurement:</p>		<p style="text-align: center; color: red;">NA</p> <p>Photo #:</p>	<ul style="list-style-type: none"> • Add curb • Add barrier • Extend ramp width •
<p>Entrance (2010 Standards – 404)</p>				
<p>1.37 Is the main entrance accessible?</p>	<p><input checked="" type="checkbox"/> Yes <input type="checkbox"/> No</p>		<p>Photo #: 1.37</p>	<ul style="list-style-type: none"> • Redesign to make it accessible • •

<p>1.38 If the main entrance is not accessible, is there an alternative accessible entrance?</p> <p>Can the alternative accessible entrance be used independently and during the same hours as the main entrance?</p>	<p><input type="checkbox"/> Yes <input type="checkbox"/> No</p> <p><input type="checkbox"/> Yes <input type="checkbox"/> No</p>		<p style="text-align: center; color: red; font-weight: bold;">NA</p> <p>Photo #:</p>	<ul style="list-style-type: none"> • Designate an entrance and make it accessible • Ensure that accessible entrance can be used independently and during the same hours as the main entrance •
<p>1.39 Do all inaccessible entrances have signs indicating the location of the nearest accessible entrance?</p>	<p><input type="checkbox"/> Yes <input type="checkbox"/> No</p>		<p style="text-align: center; color: red; font-weight: bold;">NA</p> <p>Photo #:</p>	<ul style="list-style-type: none"> • Install signs • Install signs on route before people get to inaccessible entrances so that people do not have to turn around and retrace route •
<p>1.40 If not all entrances are accessible, is there a sign at the accessible entrance with the International Symbol of Accessibility?</p>	<p><input type="checkbox"/> Yes <input type="checkbox"/> No</p>		<p style="text-align: center; color: red; font-weight: bold;">NA</p> <p>Photo #:</p>	<ul style="list-style-type: none"> • Install sign • •

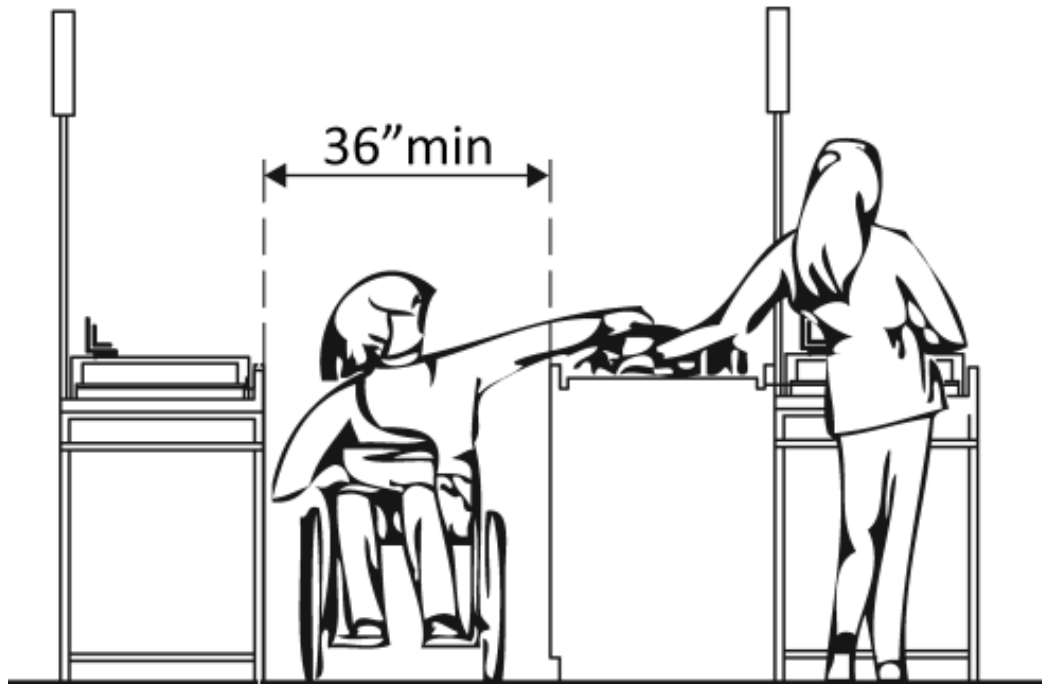
<p>1.41 Is the clear opening width of the accessible entrance door at least 32 inches, between the face of the door and the stop, when the door is open 90 degrees?</p>	<p><input checked="" type="checkbox"/> Yes <input type="checkbox"/> No</p> <p>Measurement:</p> <p>32"</p>		<p>Photo #: 1.41</p>	<ul style="list-style-type: none"> • Alter door • Install offset hinges •
<p>1.42 If there is a front approach to the pull side of the door, is there at least 18 inches of maneuvering clearance beyond the latch side plus at least 60 inches clear depth?</p> <p>On both sides of the door, is the ground or floor surface of the maneuvering clearance level (no steeper than 1:48)?</p>	<p><input checked="" type="checkbox"/> Yes <input type="checkbox"/> No</p> <p>Measurement:</p> <p><input checked="" type="checkbox"/> Yes <input type="checkbox"/> No</p> <p>Measurement:</p>		<p>Photo #: 1.37</p>	<p>See 2010 Standards 404.2.4 for maneuvering clearance requirements on the push side of the door and side approaches to the pull side of the door</p> <ul style="list-style-type: none"> • Remove obstructions • Reconfigure walls • Add automatic door opener
<p>1.43 Is the door threshold edge no more than ¼ inch high?</p> <p>Or</p> <p>No more than ¾ inch high if slope is beveled no steeper than 1:2?</p> <p>Note: The first ¼ inch of the threshold may be vertical; the rest must be beveled.</p>	<p><input type="checkbox"/> Yes <input type="checkbox"/> No</p> <p>Measurement:</p> <p><input checked="" type="checkbox"/> Yes <input type="checkbox"/> No</p> <p>Measurement:</p> <p>¾"</p>		<p>Photo #: 1.41</p>	<ul style="list-style-type: none"> • Remove or replace threshold • •

<p>1.44 Is the door equipped with hardware, including locks, that is operable with one hand and does not require tight grasping, pinching, or twisting of the wrist?</p>	<p><input checked="" type="checkbox"/> Yes <input type="checkbox"/> No</p>		<p>Photo #: 1.41</p>	<ul style="list-style-type: none"> • Replace inaccessible knob with lever, loop or push hardware • Add automatic door opener •
<p>1.45 Are the operable parts of the door hardware no less than 34 inches and no greater than 48 inches above the floor or ground surface?</p>	<p><input checked="" type="checkbox"/> Yes <input type="checkbox"/> No</p> <p>Measurement:</p>		<p>Photo #: 1.37</p>	<ul style="list-style-type: none"> • Change hardware height • •
<p>1.46 If the door has a closer, does it take at least 5 seconds to close from an open position of 90 degrees to a position of 12 degrees from the latch?</p>	<p><input type="checkbox"/> Yes <input checked="" type="checkbox"/> No</p> <p>Measurement:</p> <p>3 SEC.</p>		<p>Photo #: 1.46</p>	<ul style="list-style-type: none"> • Adjust closer • •
<p>1.47 If there are two doors in a series, e.g. vestibule, is the distance between the doors at least 48 inches plus the width of the doors when swinging into the space?</p>	<p><input type="checkbox"/> Yes <input type="checkbox"/> No</p> <p>Measurement:</p>		<p>NA</p>	<ul style="list-style-type: none"> • Remove inner door • Change door swing •

			<p>Photo #:</p>	
<p>1.48 If provided at the building entrance, are carpets or mats no higher than ½ inch thick?</p>	<p><input type="checkbox"/> Yes <input type="checkbox"/> No</p> <p>Measurement:</p>		<p style="text-align: center;">NA</p> <p>Photo #:</p>	<ul style="list-style-type: none"> • Replace or remove mats • •
<p>1.49 Are edges of carpets or mats securely attached to minimize tripping hazards?</p>	<p><input type="checkbox"/> Yes <input type="checkbox"/> No</p>		<p style="text-align: center;">NA</p> <p>Photo #:</p>	<ul style="list-style-type: none"> • Secure carpeting or mats at edges • •

ADA Checklist for Readily Achievable Barrier Removal

Priority 2 – Access to Goods & Services



Project **SDDOT Rest Area Improvements**
FHU Reference Number 13-039-01
TSP Project Number 03120855

Building **VALLEY SPRINGS**

Location **90 W., MRM 412**

Date **09-18-2013 (Inspection)**

Surveyors **Timothy Roach, AIA**
Todd Schultz, PE

Robert King, CPD

Contact Information **TSP – (605) 343-6102**

The layout of the building should allow people with disabilities to obtain goods and services and to participate in activities without assistance.



Institute for Human Centered Design
www.HumanCenteredDesign.org

November 2011




ADA National Network
Questions on the ADA 800-949-4232 voice/tty

www.ADAchecklist.org

This checklist was produced by the New England ADA Center, a project of the Institute for Human Centered Design and a member of the ADA National Network. This checklist was developed under a grant from the Department of Education, NIDRR grant number H133A060092-09A. However the contents do not necessarily represent the policy of the Department of Education, and you should not assume endorsement by the Federal Government.

Questions or comments on the checklist contact the New England ADA Center at 617-695-0085 voice/tty or ADAinfo@NewEnglandADA.org

For the full set of checklists, including the checklists for recreation facilities visit www.ADAchecklist.org.

Priority 2 – Access to Goods & Services		Comments	Possible Solutions
<p>2.1 Does the accessible entrance provide direct access to the main floor, lobby and elevator?</p>	<input checked="" type="checkbox"/> Yes <input type="checkbox"/> No	<p>Photo #: 2.1</p>	<ul style="list-style-type: none"> • Create accessible route • •
<p>Interior Accessible Route (2010 Standards – Ch.4)</p>			
<p>2.2 Are all public spaces on at least one accessible route?</p>	<input type="checkbox"/> Yes <input checked="" type="checkbox"/> No	<p>Lobby makes public spaces (toilets) accessible; however, doorways are not compliant and need modifications.</p> <p>Photo #: 2.2</p>	<ul style="list-style-type: none"> • Create accessible route • •
<p>2.3 Is the route stable, firm and slip-resistant?</p>	<input checked="" type="checkbox"/> Yes <input type="checkbox"/> No	<p>Photo #: 2.2</p>	<ul style="list-style-type: none"> • Repair uneven surfaces • •
<p>2.4 Is the route at least 36 inches wide?</p> <p>Note: The accessible route can narrow to 32 inches min. for a max. of 24 inches. These narrower portions of the route must be at least 48 inches from each other.</p>	<input checked="" type="checkbox"/> Yes <input type="checkbox"/> No Measurement:	 <p>36" min</p> <p>Photo #: 2.2</p>	<ul style="list-style-type: none"> • Widen route • •

<p>2.5 If the route is greater than 200 feet in length and no less than 36 inches wide, is there a passing space no less than 60 x 60 inches?</p>	<p><input type="checkbox"/> Yes <input type="checkbox"/> No</p> <p>Measurement:</p>		<p style="text-align: center;">NA</p> <p>Photo #:</p>	<ul style="list-style-type: none"> • Widen route for passing space • •
<p>2.6 Is the running slope no steeper than 1:20, i.e. for every inch of height change there are at least 20 inches of route run?</p>	<p><input checked="" type="checkbox"/> Yes <input type="checkbox"/> No</p> <p>Measurement:</p>		<p>Photo #: 2.2</p>	<ul style="list-style-type: none"> • Regrade • If steeper than 1:20 and no steeper than 1:12, treat as ramp and add other features such as edge protection and handrails •
<p>2.7 Is the cross slope no steeper than 1:48?</p>	<p><input checked="" type="checkbox"/> Yes <input type="checkbox"/> No</p> <p>Measurement:</p>		<p>Photo #: 2.2</p>	<ul style="list-style-type: none"> • Regrade • •

2.8 Do all objects on circulation paths through public areas, e.g. fire extinguishers, drinking fountains, signs, etc., protrude no more than 4 inches into the path?
 Or
 If an object protrudes more than 4 inches, is the bottom leading edge at 27 inches or lower above the floor?
 Or
 Is the bottom leading edge at 80 inches or higher above the floor?

Yes No

Measurement:

Yes No

Measurement:

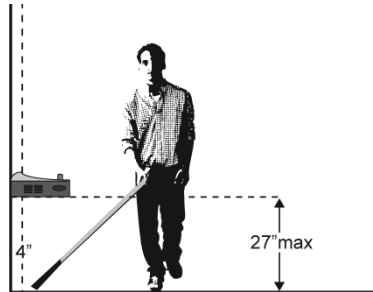
25 3/4"

Yes No

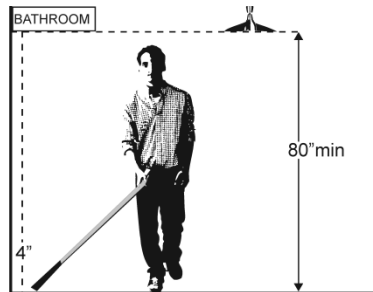
Measurement:



Or



Or



ELECTRIC WATER COOLER

Photo #: **2.8**

NA

Photo #:

- Remove object
- Add tactile warning such as permanent planter or partial walls
-

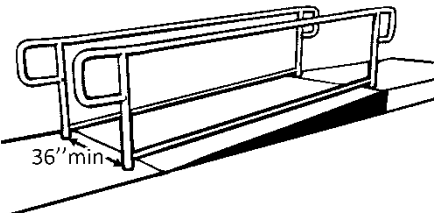
2.9 Are there elevators or platform lifts to all public stories?*

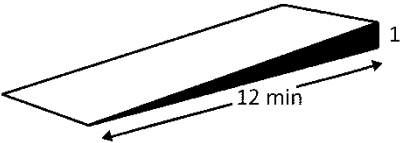
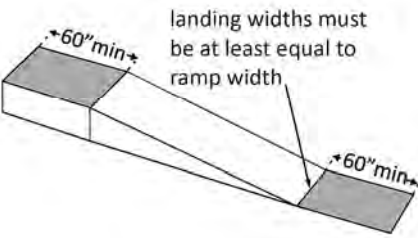
Yes No

*Vertical access is not required in new construction or alterations if a facility is less than three stories or

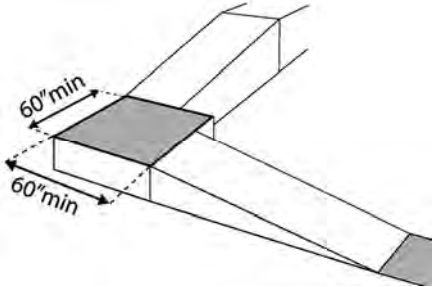
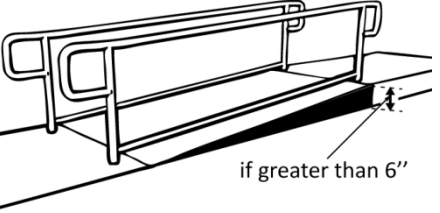
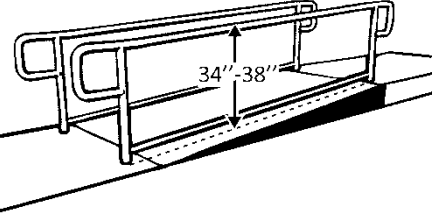
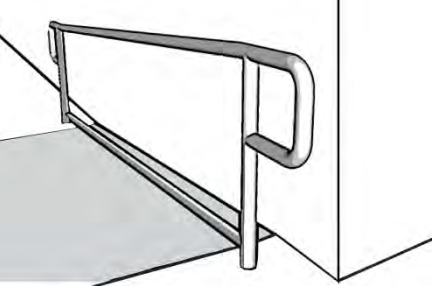
			NA	<p>has less than 3,000 square feet per story, unless a facility is a shopping center, shopping mall, professional office of a health care provider, transportation terminal, state facility or government facility</p> <ul style="list-style-type: none"> • Install if necessary • Offer goods and services on an accessible story •
			Photo #:	

Ramps (2010 Standards 404 & 505)

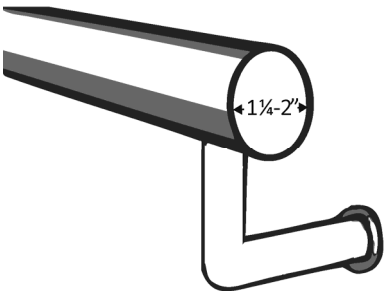
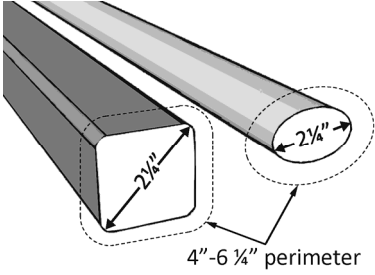
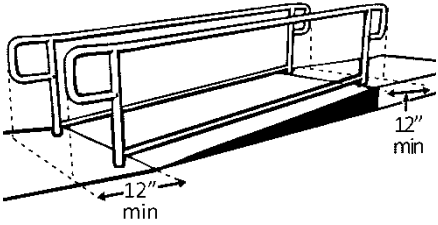
<p>2.10 If there is a ramp, is it at least 36 inches wide? If there are handrails, measure between the handrails.</p>	<p><input type="checkbox"/> Yes <input type="checkbox"/> No</p> <p>Measurement:</p>		NA	<ul style="list-style-type: none"> • Alter ramp • •
			Photo #:	
<p>2.11 Is the surface stable, firm and slip resistant?</p>	<p><input type="checkbox"/> Yes <input type="checkbox"/> No</p>		NA	<ul style="list-style-type: none"> • Change surface • •
			Photo #:	

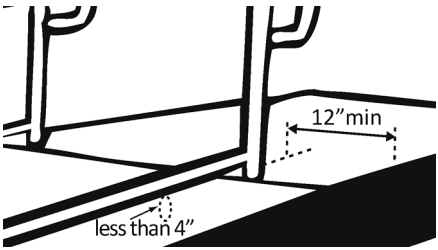
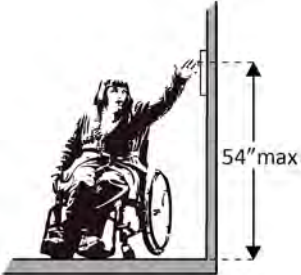
<p>2.12 For each section of the ramp, is the running slope no greater than 1:12, i.e. for every inch of height change there are at least 12 inches of ramp run?</p> <p>Note: Rises no greater than 3 inches with a slope no steeper than 1:8 and rises no greater than 6 inches with a slope no steeper than 1:10 are permitted when due to space limitations.</p>	<p><input type="checkbox"/> Yes <input type="checkbox"/> No</p> <p>Measurement:</p>		<p style="text-align: center;">NA</p> <p>Photo #:</p>	<ul style="list-style-type: none"> • Lengthen ramp to decrease slope • Reconfigure ramp to include switchbacks • Relocate ramp •
<p>2.13 Is there a level landing that is at least 60 inches long and at least as wide as the ramp:</p> <p>At the top of the ramp?</p> <p>At the bottom of the ramp?</p>	<p><input type="checkbox"/> Yes <input type="checkbox"/> No</p> <p>Measurement:</p> <p><input type="checkbox"/> Yes <input type="checkbox"/> No</p> <p>Measurement:</p>		<p style="text-align: center;">NA</p> <p>Photo #:</p>	<ul style="list-style-type: none"> • Alter ramp • Relocate ramp •

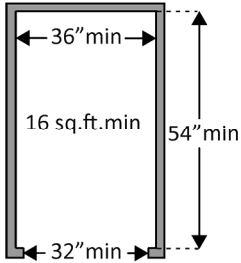
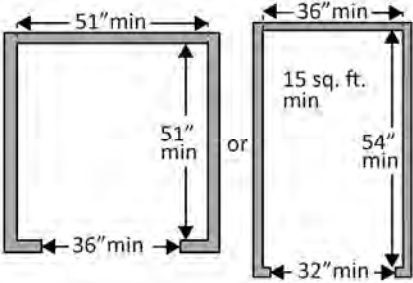
ADA Checklist for Readily Achievable Barrier Removal **Priority 2 – Access to Goods & Services**

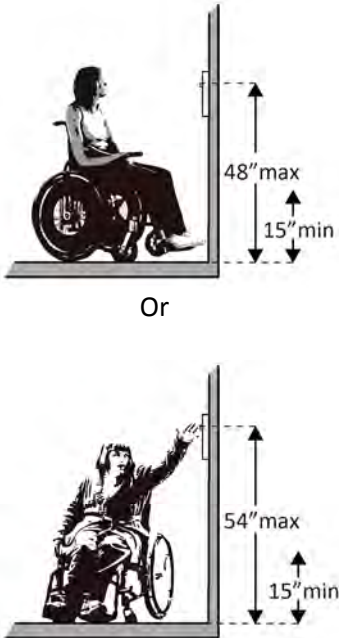

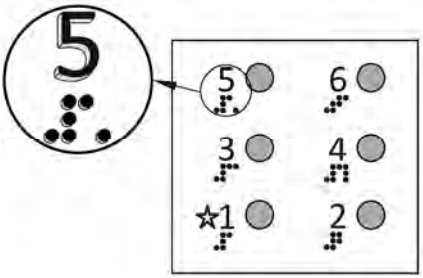
<p>2.14 Is there a level landing where the ramp changes direction that is at least 60 x 60 inches?</p>	<p><input type="checkbox"/> Yes <input type="checkbox"/> No</p> <p>Measurement:</p>	 <p>60" min 60" min</p>	<p style="text-align: center;">NA</p> <p>Photo #:</p>	<ul style="list-style-type: none"> • Increase landing size • •
<p>2.15 If the ramp has a rise higher than 6 inches are there handrails on both sides?</p>	<p><input type="checkbox"/> Yes <input type="checkbox"/> No</p> <p>Measurement:</p>	 <p>if greater than 6"</p>	<p style="text-align: center;">NA</p> <p>Photo #:</p>	<ul style="list-style-type: none"> • Add handrails • •
<p>2.16 Is the top of the handrail gripping surface no less than 34 inches and no greater than 38 inches above the ramp surface?</p>	<p><input type="checkbox"/> Yes <input type="checkbox"/> No</p> <p>Measurement:</p>	 <p>34"-38"</p>	<p style="text-align: center;">NA</p> <p>Photo #:</p>	<ul style="list-style-type: none"> • Adjust handrail height • •
<p>2.17 Is the handrail gripping surface continuous and not obstructed along the top or sides?</p> <p>If there are obstructions, is the bottom of the handrail gripping surface obstructed by no more than 20%?</p>	<p><input type="checkbox"/> Yes <input type="checkbox"/> No</p> <p><input type="checkbox"/> Yes <input type="checkbox"/> No</p> <p>Measurement:</p>		<p style="text-align: center;">NA</p> <p>Photo #:</p>	<ul style="list-style-type: none"> • Regrade to 1:20 max • If steeper than 1:20 and no steeper than 1:12, treat as a ramp and add other features such as edge protection and handrails •

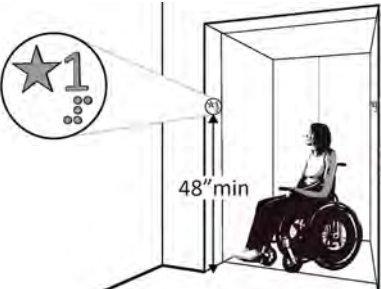
ADA Checklist for Readily Achievable Barrier Removal **Priority 2 – Access to Goods & Services**

<p>2.18 If the handrail gripping surface is circular, is it no less than 1 ¼ inches and no greater than 2 inches in diameter?</p>	<p><input type="checkbox"/> Yes <input type="checkbox"/> No</p> <p>Measurement:</p>		<p style="text-align: center; color: red;">NA</p> <p>Photo #:</p>	<ul style="list-style-type: none"> • Alter handrails • •
<p>2.19 If the handrail gripping surface is non-circular, is it no less than 4 inches and no greater than 6 ½ inches in perimeter and no more than 2 ¼ inches in cross section?</p>	<p><input type="checkbox"/> Yes <input type="checkbox"/> No</p> <p>Measurement:</p>		<p style="text-align: center; color: red;">NA</p> <p>Photo #:</p>	<ul style="list-style-type: none"> • Alter handrails • •
<p>2.20 Does the handrail:</p> <p>Extend at least 12 inches beyond the top and bottom of the ramp?</p> <p>Return to a wall, guard, or landing surface?</p>	<p><input type="checkbox"/> Yes <input type="checkbox"/> No</p> <p>Measurement:</p> <p><input type="checkbox"/> Yes <input type="checkbox"/> No</p>		<p style="text-align: center; color: red;">NA</p> <p>Photo #:</p>	<ul style="list-style-type: none"> • Alter handrails • • <p>If a 12" extension would be hazardous (in circulation path), it is not required</p>


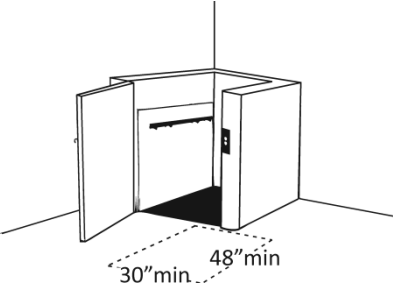
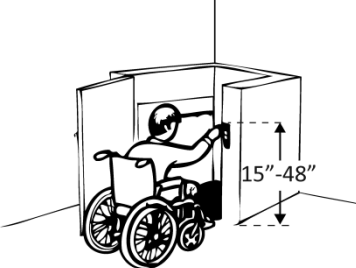
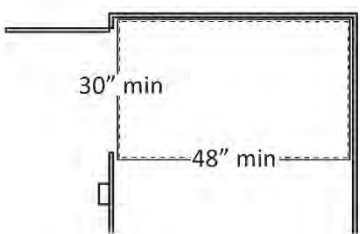
<p>2.21 To prevent wheelchair casters and crutch tips from falling off:</p> <p>Does the surface of the ramp extend at least 12 inches beyond the inside face of the handrail? Or Is there a curb or barrier that prevents the passage of a 4-inch diameter sphere?</p>	<p><input type="checkbox"/> Yes <input type="checkbox"/> No Measurement:</p> <p><input type="checkbox"/> Yes <input type="checkbox"/> No Measurement:</p>		<p style="text-align: center; color: red; font-weight: bold;">NA</p> <p>Photo #:</p>	<ul style="list-style-type: none"> • Add curb • Add barrier • Extend ramp width • •
<p>Elevators – Full Size & LULA (limited use, limited application) (2010 Standards – 407 & 408) Note: LULA elevators are often used in alterations.</p>				
<p>2.22 If there is a full size or LULA elevator, are the call buttons no higher than 54 inches above the floor?</p>	<p><input type="checkbox"/> Yes <input type="checkbox"/> No Measurement:</p>		<p style="text-align: center; color: red; font-weight: bold;">NA</p> <p>Photo #:</p>	<ul style="list-style-type: none"> • Change call button height • •
<p>2.23 If there is a full size or LULA elevator, does the sliding door reopen automatically when obstructed by an object or person?*</p>	<p><input type="checkbox"/> Yes <input type="checkbox"/> No</p>		<p style="text-align: center; color: red; font-weight: bold;">NA</p> <p>Photo #:</p>	<p>* If constructed before 3/15/2012 and manually operated, the door is not required to reopen automatically</p> <ul style="list-style-type: none"> • Install opener •

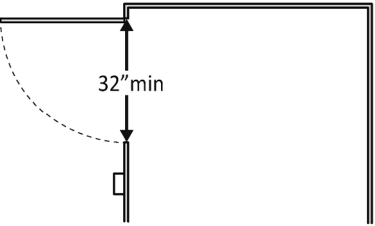
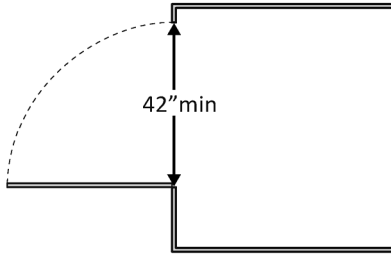
<p>2.24 If there is a LULA elevator with a swinging door:</p> <p>Is the door power-operated? <input type="checkbox"/> Yes <input type="checkbox"/> No</p> <p>Does the door remain open for at least 20 seconds when activated? <input type="checkbox"/> Yes <input type="checkbox"/> No</p> <p>Time:</p>			<p style="text-align: center;">NA</p> <p>Photo #:</p>	<ul style="list-style-type: none"> • Add power operated door • Adjust opening time •
<p>2.25 If there is a full size elevator:</p> <p>Is the interior at least 54 inches deep by at least 36 inches wide with at least 16 sq. ft. of clear floor area? <input type="checkbox"/> Yes <input type="checkbox"/> No</p> <p>Measurement:</p> <p>Is the door opening width at least 32 inches? <input type="checkbox"/> Yes <input type="checkbox"/> No</p> <p>Measurement:</p>			<p style="text-align: center;">NA</p> <p>Photo #:</p>	<ul style="list-style-type: none"> • Replace elevator • •
<p>2.26 If there is a LULA elevator, is the interior:</p> <p>At least 51 x 51 inches with a door opening width of at least 36 inches? <input type="checkbox"/> Yes <input type="checkbox"/> No</p> <p>Measurement:</p> <p>Or</p> <p>At least 54 inches deep by at least 36 inches wide with at least 15 sq. ft. of clear floor area and a door opening width of at least 32 inches? <input type="checkbox"/> Yes <input type="checkbox"/> No</p> <p>Measurement:</p>			<p style="text-align: center;">NA</p> <p>Photo #:</p>	<ul style="list-style-type: none"> • Replace elevator • •

<p>2.27 If there is a full size or LULA elevator, are the in-car controls:</p> <p>No less than 15 inches and no greater 48 inches above the floor? Or Up to 54 inches above the floor for a parallel approach?</p>	<p><input type="checkbox"/> Yes <input type="checkbox"/> No Measurement:</p> <p><input type="checkbox"/> Yes <input type="checkbox"/> No Measurement:</p>		<p style="text-align: center;">NA</p> <p>Photo #:</p>	<ul style="list-style-type: none"> • Change control height • •
<p>2.28 If there is a LULA elevator, are the in-car controls centered on a side wall?</p>	<p><input type="checkbox"/> Yes <input type="checkbox"/> No Measurement:</p>		<p style="text-align: center;">NA</p> <p>Photo #:</p>	<ul style="list-style-type: none"> • Reconfigure controls • •
<p>2.29 If there is a full size or LULA elevator:</p> <p>Are the car control buttons designated with raised characters? Are the car control buttons designated with Braille?</p>	<p><input type="checkbox"/> Yes <input type="checkbox"/> No</p> <p><input type="checkbox"/> Yes <input type="checkbox"/> No</p>		<p style="text-align: center;">NA</p> <p>Photo #:</p>	<ul style="list-style-type: none"> • Add raised characters • Add Braille •

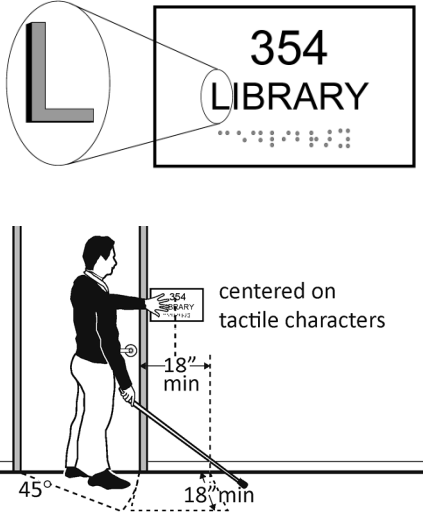
<p>2.30 If there is a full size or LULA elevator, are there audible signals which sound as the car passes or is about to stop at a floor?</p>	<p><input type="checkbox"/> Yes <input type="checkbox"/> No</p>		<p>Photo #: NA</p>	<ul style="list-style-type: none"> • Install audible signals • •
<p>2.31 If there is a full size or LULA elevator:</p> <p>Is there a sign on both door jambs at every floor identifying the floor?</p> <p>Is there a tactile star on both jambs at the main entry level?</p> <p>Do text characters contrast with their backgrounds?</p> <p>Are text characters raised?</p> <p>Is there Braille?</p> <p>Is the sign mounted between 48 inches to the baseline of the lowest character and 60 inches to the baseline of the highest character above the floor?*</p>	<p><input type="checkbox"/> Yes <input type="checkbox"/> No</p> <p><input type="checkbox"/> Yes <input type="checkbox"/> No</p> <p><input type="checkbox"/> Yes <input type="checkbox"/> No</p> <p><input type="checkbox"/> Yes <input type="checkbox"/> No</p> <p><input type="checkbox"/> Yes <input type="checkbox"/> No</p> <p><input type="checkbox"/> Yes <input type="checkbox"/> No</p> <p><input type="checkbox"/> Yes <input type="checkbox"/> No</p> <p>Measurement:</p>		<p>Photo #: NA</p>	<ul style="list-style-type: none"> • Install signs • Change sign height • • <p>* If constructed before 3/15/2012 and mounted no higher than 60 inches to the centerline of the sign, relocation is not required</p>
<p>Platform Lifts (2010 Standards – 410)</p>				

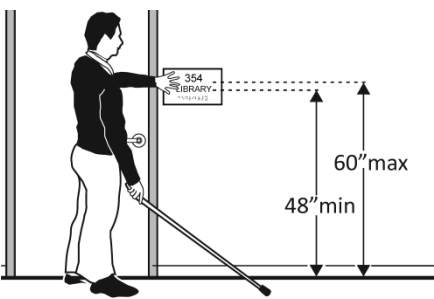
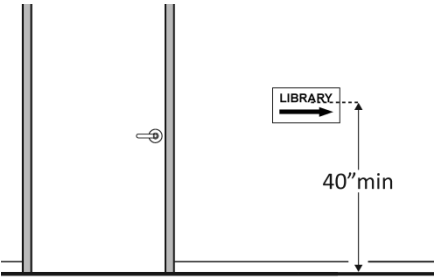
ADA Checklist for Readily Achievable Barrier Removal **Priority 2 – Access to Goods & Services**

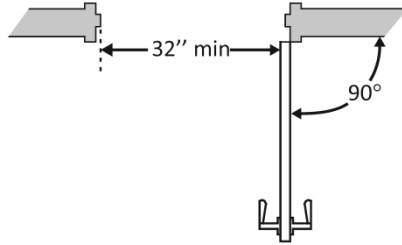
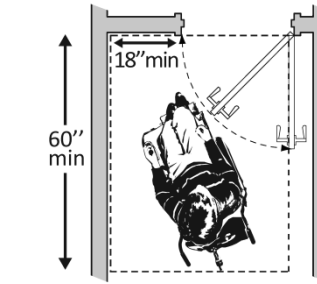
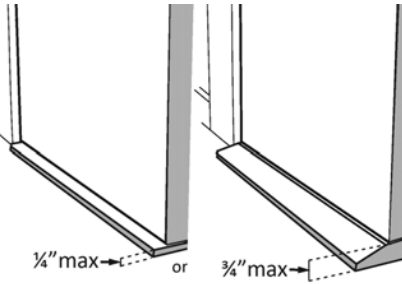
<p>2.32 If a lift is provided, can it be used without assistance from others?</p>	<p><input type="checkbox"/> Yes <input type="checkbox"/> No</p>		<p style="text-align: center;">NA</p> <p>Photo #:</p>	<ul style="list-style-type: none"> • Reconfigure so independently operable • •
<p>2.33 Is there a clear floor space at least 30 inches wide by at least 48 inches long for a person using a wheelchair to approach and reach the controls to use the lift?</p>	<p><input type="checkbox"/> Yes <input type="checkbox"/> No</p> <p>Measurement:</p>		<p style="text-align: center;">NA</p> <p>Photo #:</p>	<ul style="list-style-type: none"> • Remove obstructions • •
<p>2.34 Are the lift controls no less than 15 inches and no greater than 48 inches above the floor?</p>	<p><input type="checkbox"/> Yes <input type="checkbox"/> No</p> <p>Measurement:</p>		<p style="text-align: center;">NA</p> <p>Photo #:</p>	<ul style="list-style-type: none"> • Change control height • •
<p>2.35 Is there a clear floor space at least 30 inches wide by at least 48 inches long inside the lift?</p>	<p><input type="checkbox"/> Yes <input type="checkbox"/> No</p> <p>Measurement:</p>		<p style="text-align: center;">NA</p> <p>Photo #:</p>	<ul style="list-style-type: none"> • Replace lift • •

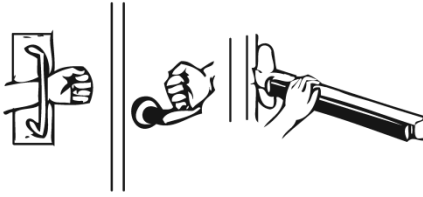
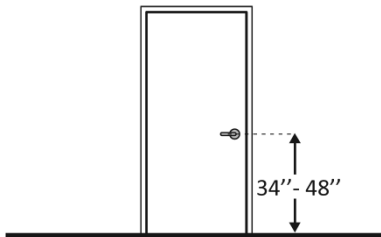
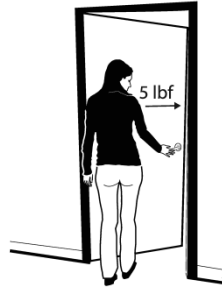
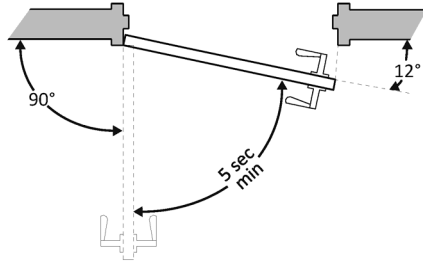
<p>2.36 If there is an end door, is the clear opening width at least 32 inches?</p>	<p><input type="checkbox"/> Yes <input type="checkbox"/> No</p> <p>Measurement:</p>		<p style="text-align: center; color: red; font-weight: bold;">NA</p> <p>Photo #:</p>	<ul style="list-style-type: none"> • Alter door width • •
<p>2.37 If there is a side door, is the clear opening width at least 42 inches?</p>	<p><input type="checkbox"/> Yes <input type="checkbox"/> No</p> <p>Measurement:</p>		<p style="text-align: center; color: red; font-weight: bold;">NA</p> <p>Photo #:</p>	<ul style="list-style-type: none"> • Alter door width • •

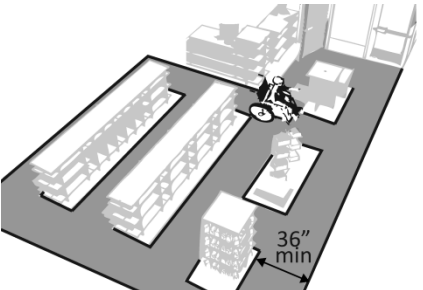

Signs (2010 Standards – 703) Note: “Tactile characters” are read using touch, i.e. raised characters and Braille.

<p>2.38 If there are signs designating permanent rooms and spaces not likely to change over time, e.g. room numbers and letters, room names, and exit signs:</p> <p>Do text characters contrast with their backgrounds?</p> <p>Are text characters raised?</p> <p>Is there Braille?</p> <p>Is the sign mounted: On the wall on the latch side of the door?</p>	<p><input checked="" type="checkbox"/> Yes <input type="checkbox"/> No</p> <p><input checked="" type="checkbox"/> Yes <input type="checkbox"/> No</p> <p><input checked="" type="checkbox"/> Yes <input type="checkbox"/> No</p> <p><input checked="" type="checkbox"/> Yes <input type="checkbox"/> No</p>		<p style="text-align: center; color: red; font-weight: bold;">NA</p> <p>Photo #:</p>	<ul style="list-style-type: none"> • Install tactile sign • Relocate sign •
---	---	---	--	--

<p>Note: Signs are permitted on the push side of doors with closers and without hold-open devices.</p> <p>With clear floor space beyond the arc of the door swing between the closed position and 45-degree open position, at least 18 x 18 inches centered on the tactile characters?*</p> <p>So the baseline of the lowest character is at least 48 inches above the floor and the baseline of the highest character is no more than 60 inches above the floor? *</p> <p>Note: If the sign is at double doors with one active leaf, the sign should be on the inactive leaf; if both leaves are active, the sign should be on the wall to the right of the right leaf.</p>	<p><input type="checkbox"/> Yes <input type="checkbox"/> No</p> <p>Measurement: NA</p> <p><input checked="" type="checkbox"/> Yes <input type="checkbox"/> No</p> <p>Measurement: 53" BOTTOM 58" TOP</p>	 <p>Photo #:</p>	<p>*If constructed before 3/15/2010 and a person may approach within 3 inches of the sign without encountering protruding objects or standing within the door swing, relocation not required</p> <p>*If constructed before 3/15/2012 and mounted no higher than 60 inches to the centerline of the sign, relocation not required</p>
<p>2.39 If there are signs that provide direction to or information about interior spaces:</p> <p>Do text characters contrast with their backgrounds?</p> <p>Is the sign mounted so that characters are at least 40 inches above the floor?</p>	<p><input type="checkbox"/> Yes <input type="checkbox"/> No</p> <p><input type="checkbox"/> Yes <input type="checkbox"/> No</p> <p>Measurement:</p>	 <p>Photo #:</p>	<p>NA</p> <ul style="list-style-type: none"> • Install signs with contrasting characters • Change sign height • <p>Raised characters and Braille are not required</p>

Interior Doors – to classrooms, medical exam rooms, conference rooms, etc. (2010 Standards – 404)				
<p>2.40 Is the door opening width at least 32 inches clear, between the face of the door and the stop, when the door is open 90 degrees?</p>	<p><input type="checkbox"/> Yes <input type="checkbox"/> No</p> <p>Measurement:</p>		<p style="text-align: center; color: red; font-weight: bold;">NA</p> <p>Photo #:</p>	<ul style="list-style-type: none"> • Install offset hinges • Alter the doorway •
<p>2.41 If there is a front approach to the pull side of the door, is there at least 18 inches of maneuvering clearance beyond the latch side plus at least 60 inches clear depth?</p> <p>On both sides of the door, is the floor surface of the maneuvering clearance level (no steeper than 1:48)?</p>	<p><input type="checkbox"/> Yes <input type="checkbox"/> No</p> <p>Measurement:</p> <p><input type="checkbox"/> Yes <input type="checkbox"/> No</p> <p>Measurement:</p>		<p style="text-align: center; color: red; font-weight: bold;">NA</p> <p>Photo #:</p>	<ul style="list-style-type: none"> • Remove obstructions • Reconfigure walls • Add automatic door opener <p>See 2010 Standards 404.2.4 for maneuvering clearance requirements on the push side of the door and side approaches to the pull side of the door</p>
<p>2.42 Is the door threshold edge no more than ¼ inch high?</p> <p>Or</p> <p>No more than ¾ inch high if slope is beveled no steeper than 1:2?</p> <p>Note: The first ¼ inch of the threshold may be vertical; the rest must be beveled.</p>	<p><input type="checkbox"/> Yes <input type="checkbox"/> No</p> <p>Measurement:</p> <p><input type="checkbox"/> Yes <input type="checkbox"/> No</p> <p>Measurement:</p>		<p style="text-align: center; color: red; font-weight: bold;">NA</p> <p>Photo #:</p>	<ul style="list-style-type: none"> • Remove or replace threshold • •

<p>2.43 Is the door equipped with hardware that is operable with one hand and does not require tight grasping, pinching and twisting of the wrist?</p>	<p><input type="checkbox"/> Yes <input type="checkbox"/> No</p>		<p style="text-align: center;">NA</p> <p>Photo #:</p>	<ul style="list-style-type: none"> • Replace inaccessible knob with lever, loop or push hardware • Add automatic door opener •
<p>2.44 Are the operable parts of the hardware no less than 34 inches and no greater than 48 inches above the floor?</p>	<p><input type="checkbox"/> Yes <input type="checkbox"/> No</p> <p>Measurement:</p>		<p style="text-align: center;">NA</p> <p>Photo #:</p>	<ul style="list-style-type: none"> • Change hardware height • •
<p>2.45 Can the door be opened easily (5 pounds maximum force)?</p> <p>Note: You can use a pressure gauge or fish scale to measure force. If you do not have a pressure gauge or fish scale you will need to judge whether the door is easy to open.</p>	<p><input type="checkbox"/> Yes <input type="checkbox"/> No</p> <p>Measurement:</p>		<p style="text-align: center;">NA</p> <p>Photo #:</p>	<ul style="list-style-type: none"> • Adjust or replace closers • Install lighter doors • Install power-assisted or automatic door openers
<p>2.46 If the door has a closer, does it take at least 5 seconds to close from an open position of 90 degrees to a position of 12 degrees from the latch?</p>	<p><input type="checkbox"/> Yes <input type="checkbox"/> No</p> <p>Measurement:</p>		<p style="text-align: center;">NA</p> <p>Photo #:</p>	<ul style="list-style-type: none"> • Adjust closer • •

Rooms and Spaces – stores, supermarkets, libraries, etc. (2010 Standards – 302, 304, & 402)				
<p>2.47 Are aisles and pathways to goods and services, and to one of each type of sales and service counters, at least 36 inches wide?</p>	<p><input type="checkbox"/> Yes <input type="checkbox"/> No</p> <p>Measurement:</p>		<p style="text-align: center;">NA</p> <p>Photo #:</p>	<ul style="list-style-type: none"> • Rearrange goods, equipment and furniture • •
<p>2.48 Are floor surfaces stable, firm and slip resistant?</p>	<p><input type="checkbox"/> Yes <input type="checkbox"/> No</p>		<p style="color: red;">Floor tile has become less abrasive with age...consider carpet pads at doorways at a minimum.</p> <p>Photo #: 2.48</p>	<ul style="list-style-type: none"> • Change floor surface • •
<p>2.49 If there is carpet:</p> <p>Is it no higher than ½ inch?</p> <p>Is it securely attached along the edges?</p>	<p><input type="checkbox"/> Yes <input type="checkbox"/> No</p> <p>Measurement:</p> <p><input type="checkbox"/> Yes <input type="checkbox"/> No</p>		<p style="text-align: center;">NA</p> <p>Photo #:</p>	<ul style="list-style-type: none"> • Replace carpet • •
Controls – light switches, security and intercom systems, emergency/alarm boxes, etc. (2010 Standards – 309)				

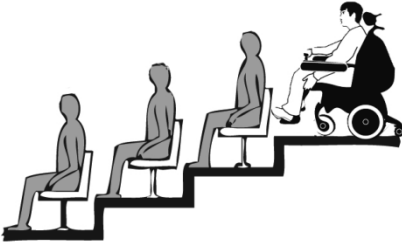
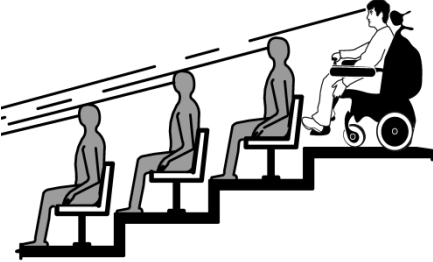
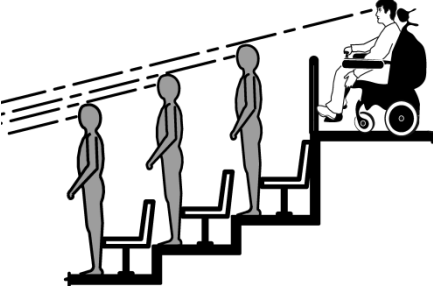

ADA Checklist for Readily Achievable Barrier Removal **Priority 2 – Access to Goods & Services**

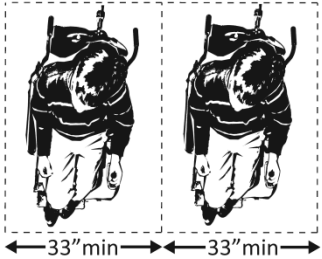
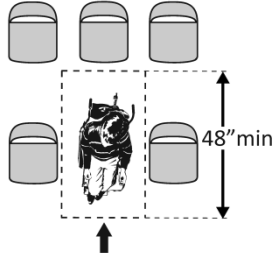
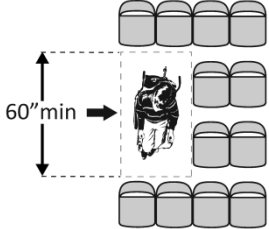
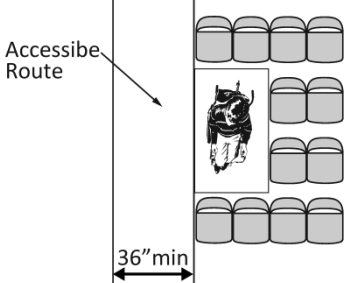
<p>2.50 Is there a clear floor space at least 30 inches wide by at least 48 inches long for a forward or parallel approach?</p> <p>Are the operable parts no higher than 48 inches above the floor?*</p>	<p><input type="checkbox"/> Yes <input type="checkbox"/> No</p> <p>Measurement:</p> <p><input type="checkbox"/> Yes <input type="checkbox"/> No</p> <p>Measurement:</p> <p>NA</p>		<p>Photo #:</p>	<ul style="list-style-type: none"> • Change height of control • • <p>*If constructed before 3/15/2012 and a parallel approach is provided, controls can be 54 inches above the floor</p>
---	--	--	-----------------	---

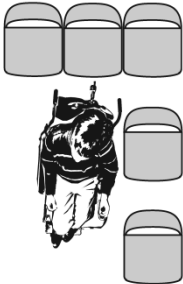

<p>2.51 Can the control be operated with one hand and without tight grasping, pinching, or twisting of the wrist?</p>	<p><input type="checkbox"/> Yes <input type="checkbox"/> No</p>		<p>NA</p> <p>Photo #:</p>	<ul style="list-style-type: none"> • Replace control • •
--	---	--	----------------------------------	---

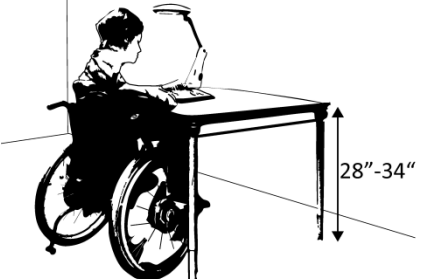
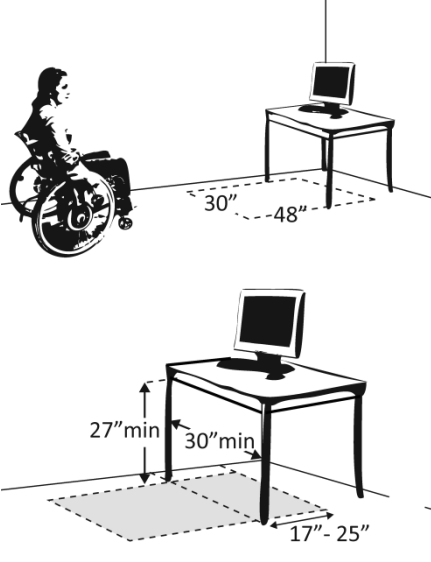
Seating: Assembly Areas – theaters, auditoriums, stadiums, theater style classrooms, etc. (2010 Standards – 221 & 802)

<p>2.52 Are an adequate number of wheelchair spaces provided?</p>	<p><input type="checkbox"/> Yes <input type="checkbox"/> No</p> <p>Total #:</p> <p>Wheelchair #:</p>	<table border="1"> <thead> <tr> <th># of Seats</th> <th>Wheelchair Spaces</th> </tr> </thead> <tbody> <tr> <td>4 - 25</td> <td>1</td> </tr> <tr> <td>26 - 50</td> <td>2</td> </tr> <tr> <td>51 - 150</td> <td>4</td> </tr> <tr> <td>151 - 300</td> <td>5</td> </tr> <tr> <td colspan="2">300+ see 2010 Standards 221.2.1.</td> </tr> </tbody> </table>	# of Seats	Wheelchair Spaces	4 - 25	1	26 - 50	2	51 - 150	4	151 - 300	5	300+ see 2010 Standards 221.2.1.		<p>NA</p> <p>Photo #:</p>	<ul style="list-style-type: none"> • Reconfigure to add wheelchair spaces • •
# of Seats	Wheelchair Spaces															
4 - 25	1															
26 - 50	2															
51 - 150	4															
151 - 300	5															
300+ see 2010 Standards 221.2.1.																

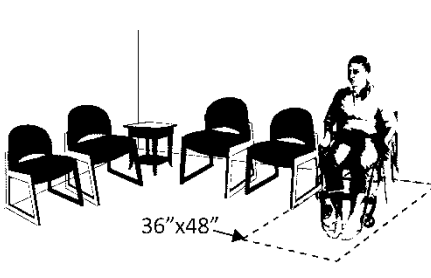
<p>2.53 Are wheelchair spaces dispersed to allow location choices and viewing angles equivalent to other seating, including specialty seating areas that provide distinct services and amenities?</p>	<p><input type="checkbox"/> Yes <input type="checkbox"/> No</p>		<p style="text-align: center;">NA</p> <p>Photo #:</p>	<ul style="list-style-type: none"> • Reconfigure to disperse wheelchair spaces • •
<p>2.54 Where people are expected to remain seated, do people in wheelchair spaces have a clear line of sight over and between the heads of others in front of them?</p>	<p><input type="checkbox"/> Yes <input type="checkbox"/> No</p>		<p style="text-align: center;">NA</p> <p>Photo #:</p>	<ul style="list-style-type: none"> • Alter for line of sight • •
<p>2.55 Where people are expected to stand, do people in wheelchair spaces have a clear line of sight over and between the heads of others in front of them?</p>	<p><input type="checkbox"/> Yes <input type="checkbox"/> No</p>		<p style="text-align: center;">NA</p> <p>Photo #:</p>	<ul style="list-style-type: none"> • Alter for line of sight • •
<p>2.56 If there is a single wheelchair space, is it at least 36 inches wide?</p>	<p><input type="checkbox"/> Yes <input type="checkbox"/> No</p> <p>Measurement:</p>	 <p style="text-align: center;">← 36" min →</p>	<p style="text-align: center;">NA</p> <p>Photo #:</p>	<ul style="list-style-type: none"> • Alter space • •

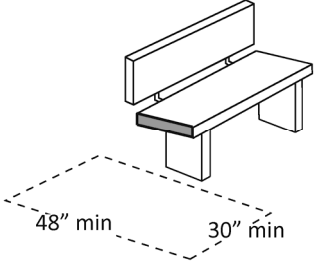
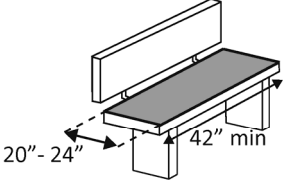
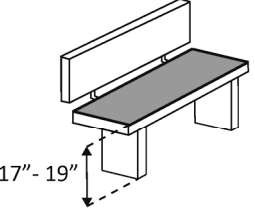
<p>2.57 If there are two adjacent wheelchair spaces, are they each at least 33 inches wide?</p>	<p><input type="checkbox"/> Yes <input type="checkbox"/> No</p> <p>Measurement:</p>		<p style="text-align: center;">NA</p> <p>Photo #:</p>	<ul style="list-style-type: none"> • Alter spaces • •
<p>2.58 If the wheelchair space can be entered from the front or rear, is it at least 48 inches deep?</p>	<p><input type="checkbox"/> Yes <input type="checkbox"/> No</p> <p>Measurement:</p>		<p style="text-align: center;">NA</p> <p>Photo #:</p>	<ul style="list-style-type: none"> • Alter space • •
<p>2.59 If the wheelchair space can only be entered from the side, is it at least 60 inches deep?</p>	<p><input type="checkbox"/> Yes <input type="checkbox"/> No</p> <p>Measurement:</p>		<p style="text-align: center;">NA</p> <p>Photo #:</p>	<ul style="list-style-type: none"> • Alter space • •
<p>2.60 Do wheelchair spaces adjoin, but not overlap, accessible routes?</p>	<p><input type="checkbox"/> Yes <input type="checkbox"/> No</p>		<p style="text-align: center;">NA</p> <p>Photo #:</p>	<ul style="list-style-type: none"> • Alter spaces • •

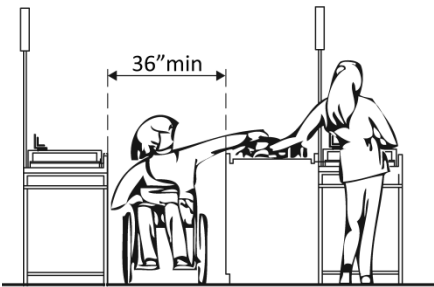
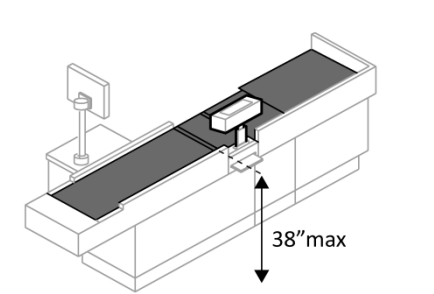
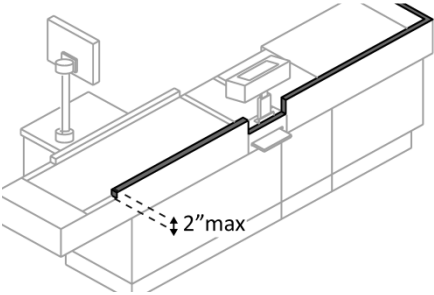
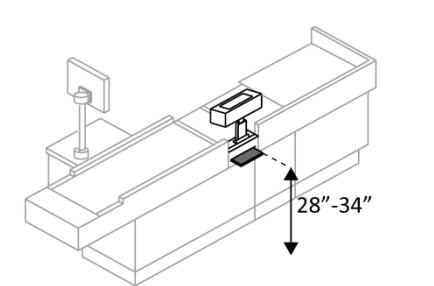
<p>2.61 Is there at least one companion seat for each wheelchair space?</p>	<p><input type="checkbox"/> Yes <input type="checkbox"/> No</p>		<p style="text-align: center;">NA</p> <p>Photo #:</p>	<ul style="list-style-type: none"> • Add companion seats • •
<p>2.62 Is the companion seat located so the companion is shoulder-to-shoulder with the person in a wheelchair?</p>	<p><input type="checkbox"/> Yes <input type="checkbox"/> No</p>		<p style="text-align: center;">NA</p> <p>Photo #:</p>	<ul style="list-style-type: none"> • Alter seating • •
<p>2.63 Is the companion seat equivalent in size, quality, comfort and amenities to seating in the immediate area?</p>	<p><input type="checkbox"/> Yes <input type="checkbox"/> No</p>		<p style="text-align: center;">NA</p> <p>Photo #:</p>	<ul style="list-style-type: none"> • Add equivalent seating • •
<p>Seating: At dining surfaces (restaurants, cafeterias, bars, etc.) and non-employee work surfaces (libraries, conference rooms, etc.) (2010 Standards – 226 & 902)</p>				
<p>2.64 Are at least 5%, but no fewer than one, of seating and standing spaces accessible for people who use wheelchairs?</p>	<p><input type="checkbox"/> Yes <input type="checkbox"/> No</p> <p>Total #:</p> <p>Wheelchair #:</p>		<p style="text-align: center;">NA</p> <p>Photo #:</p>	<ul style="list-style-type: none"> • Alter to provide accessible spaces • •
<p>2.65 Is there a route at least 36 inches wide to accessible seating?</p>	<p><input type="checkbox"/> Yes <input type="checkbox"/> No</p> <p>Measurement:</p>		<p style="text-align: center;">NA</p> <p>Photo #:</p>	<ul style="list-style-type: none"> • Widen route • •


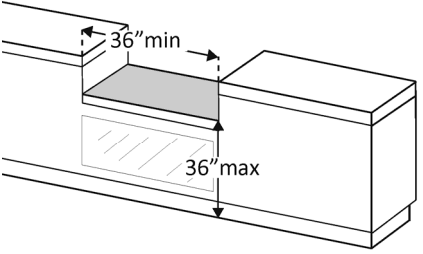
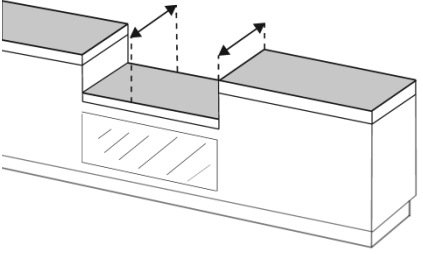
<p>2.66 At the accessible space(s), is the top of the accessible surface no less than 28 inches and no greater than 34 inches above the floor?</p>	<p><input type="checkbox"/> Yes <input type="checkbox"/> No</p> <p>Measurement:</p>		<p style="text-align: center;">NA</p> <p>Photo #:</p>	<ul style="list-style-type: none"> • Alter surface height • •
<p>2.67 Is there a clear floor space at least 30 inches wide by at least 48 inches long for a forward approach?</p> <p>Does it extend no less than 17 inches and no greater than 25 inches under the surface?</p> <p>Is there knee space at least 27 inches high and at least 30 inches wide?</p>	<p><input type="checkbox"/> Yes <input type="checkbox"/> No</p> <p>Measurement:</p> <p><input type="checkbox"/> Yes <input type="checkbox"/> No</p> <p>Measurement:</p> <p><input type="checkbox"/> Yes <input type="checkbox"/> No</p> <p>Measurement:</p>		<p style="text-align: center;">NA</p> <p>Photo #:</p>	<ul style="list-style-type: none"> • Alter table or work surface • Add accessible table or work surface •

Seating: General – reception areas, waiting rooms, etc. (2010 Standards – 801)

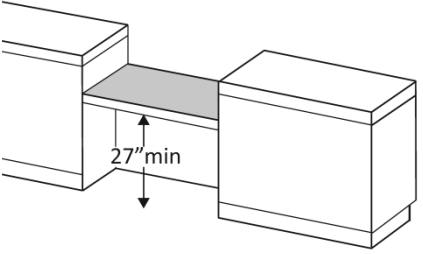
<p>2.68 Is there at least one space at least 36 inches wide by at least 48 inches long for a person in a wheelchair?</p>	<p><input type="checkbox"/> Yes <input type="checkbox"/> No</p> <p>Measurement:</p>		<p style="text-align: center;">NA</p> <p>Photo #:</p>	<ul style="list-style-type: none"> • Move furniture and equipment to provide space • •
---	---	--	--	---

Benches – In locker rooms, dressing rooms, fitting rooms (2010 Standards – 803 & 903)				
<p>2.69 In locker rooms, dressing rooms and fitting rooms, is there at least one room with a bench?</p>	<p><input type="checkbox"/> Yes <input type="checkbox"/> No</p>		<p>NA</p>	<ul style="list-style-type: none"> • Add bench • •
<p>2.70 Is there a clear floor space at least 30 inches wide by at least 48 inches long at the end of the bench and parallel to the short axis of the bench?</p> <p>Is the bench seat at least 42 inches long and no less than 20 inches and no greater than 24 inches deep?</p> <p>Does the bench have back support or is it affixed to a wall?</p> <p>Is the top of the bench seat no less than 17 inches and no greater than 19 inches above the floor?</p>	<p><input type="checkbox"/> Yes <input type="checkbox"/> No Measurement:</p> <p><input type="checkbox"/> Yes <input type="checkbox"/> No Measurement:</p> <p><input type="checkbox"/> Yes <input type="checkbox"/> No</p> <p><input type="checkbox"/> Yes <input type="checkbox"/> No Measurement:</p>	  	<p>NA</p>	<ul style="list-style-type: none"> • Move bench • Replace bench • Affix bench to wall • •

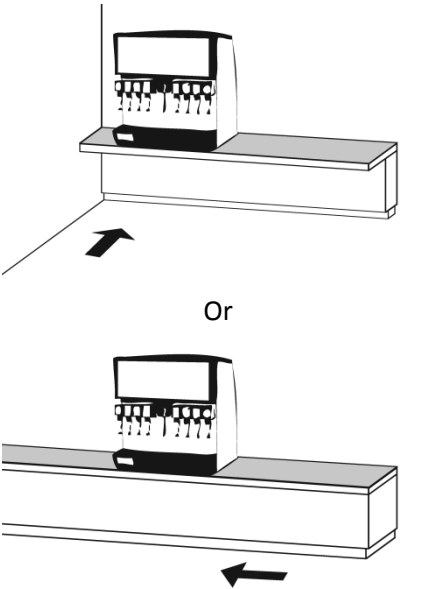
Check-Out Aisles – supermarkets, large retail stores, etc. (2010 Standards – 904)				
<p>2.71 Is the aisle at least 36 inches wide?</p>	<p><input type="checkbox"/> Yes <input type="checkbox"/> No</p> <p>Measurement:</p>		<p>NA</p> <p>Photo #:</p>	<ul style="list-style-type: none"> • Widen aisle • •
<p>2.72 Is the counter surface of at least one aisle no higher than 38 inches above the floor?</p>	<p><input type="checkbox"/> Yes <input type="checkbox"/> No</p> <p>Measurement:</p>		<p>NA</p> <p>Photo #:</p>	<ul style="list-style-type: none"> • Lower counter • •
<p>2.73 Is the top of the counter edge protection no higher than 2 inches above the counter surface?</p>	<p><input type="checkbox"/> Yes <input type="checkbox"/> No</p> <p>Measurement:</p>		<p>NA</p> <p>Photo #:</p>	<ul style="list-style-type: none"> • Lower edge protection • •
<p>2.74 If there is a check writing surface, is the top no less than 28 inches and no greater than 34 inches above the floor?</p>	<p><input type="checkbox"/> Yes <input type="checkbox"/> No</p> <p>Measurement:</p>		<p>NA</p> <p>Photo #:</p>	<ul style="list-style-type: none"> • Alter check writing surface • •

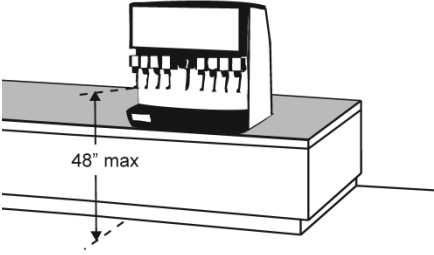
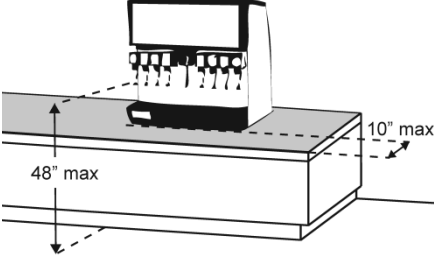
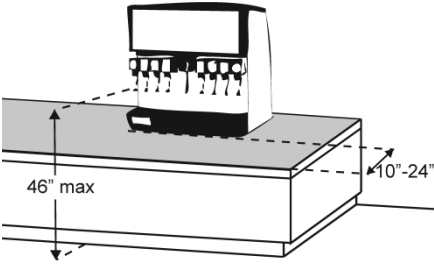
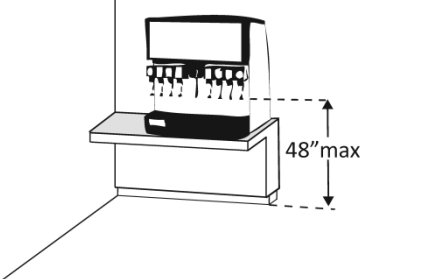
<p>2.75 If there is more than one check-out aisle is there a sign with the International Symbol of Accessibility at the accessible aisle?</p>	<p><input type="checkbox"/> Yes <input type="checkbox"/> No</p>		<p style="text-align: center;">NA</p> <p>Photo #:</p>	<ul style="list-style-type: none"> • Add sign • •
<p>Sales & Service Counters – banks, stores, dry cleaners, auto repair shops, fitness clubs, etc. (2010 Standards – 904)</p>				
<p>2.76 Is there a portion of at least one of each type of counter that is:</p> <p>No higher than 36 inches above the floor?</p> <p>At least 36 inches long?</p>	<p><input type="checkbox"/> Yes <input checked="" type="checkbox"/> No</p> <p>Measurement: 42"</p> <p><input checked="" type="checkbox"/> Yes <input type="checkbox"/> No</p> <p>Measurement: 72"</p>		<p>Photo #: 2.76</p>	<ul style="list-style-type: none"> • Lower section of counter • Lengthen section of counter •
<p>2.77 Does the accessible portion of the counter extend the same depth as the counter top?</p>	<p><input type="checkbox"/> Yes <input type="checkbox"/> No</p> <p>Measurement:</p>		<p style="text-align: center;">NA</p> <p>Photo #:</p>	<ul style="list-style-type: none"> • Alter accessible portion • •

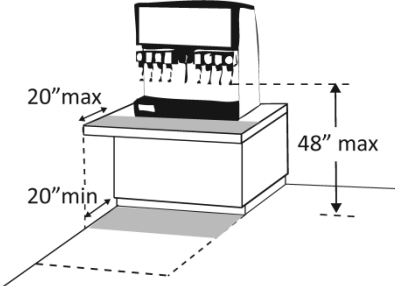
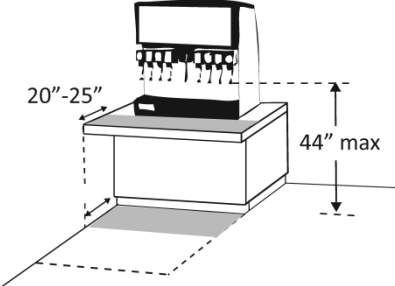
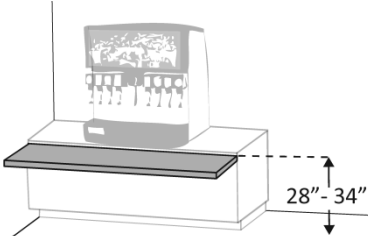
<p>2.78 Is there a clear floor space at least 30 inches wide by at least 48 inches long for a forward or parallel approach?</p>	<p><input type="checkbox"/> Yes <input type="checkbox"/> No</p> <p><input type="checkbox"/> Parallel Measurement:</p> <p><input type="checkbox"/> Forward Measurement:</p>		<p style="text-align: center; color: red; font-weight: bold;">NA</p> <p>Photo #:</p>	<ul style="list-style-type: none"> • Reconfigure to provide a parallel or forward approach • •
<p>2.79 For a parallel approach, is the clear floor space positioned with the 48 inches adjacent to the accessible length of counter?</p>	<p><input type="checkbox"/> Yes <input type="checkbox"/> No</p> <p>Measurement:</p>		<p style="text-align: center; color: red; font-weight: bold;">NA</p> <p>Photo #:</p>	<ul style="list-style-type: none"> • If a parallel approach is not possible, a forward approach is required • •
<p>2.80 For a forward approach:</p> <p>Do no less than 17 and no greater than 25 inches of the clear floor space extend under the accessible length of the counter?</p> <p>Is there at least 27 inches clearance from the floor to the</p>	<p><input type="checkbox"/> Yes <input type="checkbox"/> No</p> <p>Measurement:</p> <p><input type="checkbox"/> Yes <input type="checkbox"/> No</p>		<p style="text-align: center; color: red; font-weight: bold;">NA</p> <p>Photo #:</p>	<ul style="list-style-type: none"> • Reconfigure to provide knee clearance • •

<p>bottom of the counter?</p>	<p>Measurement:</p>		<p>Photo #:</p>	
-------------------------------	---------------------	--	-----------------	--

Food Service Lines – in cafeterias, salad bars, eat-in fast food establishments, etc. (2010 Standards – 904)

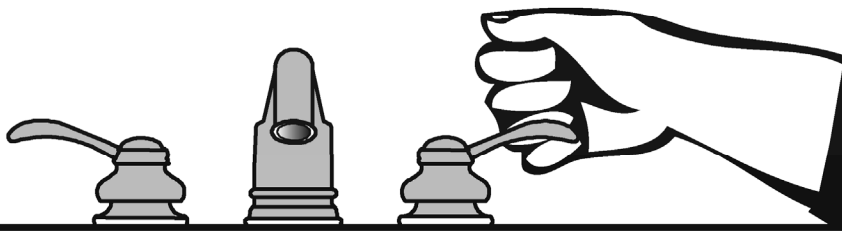
<p>2.81 Does at least one of each type of self-service shelf or dispensing device for tableware, dishware, condiments, food and beverages have a forward or parallel approach?</p>	<p><input type="checkbox"/> Yes <input type="checkbox"/> No</p> <p><input type="checkbox"/> Forward</p> <p><input type="checkbox"/> Parallel</p>		<p style="color: red; text-align: center;">NA</p> <p>Photo #:</p>	<ul style="list-style-type: none"> • Reconfigure to provide approach • •
---	--	---	---	---

<p>2.82 If there is an unobstructed parallel approach, is the shelf or dispensing device no higher than 48 inches above the floor?</p>	<p><input type="checkbox"/> Yes <input type="checkbox"/> No</p> <p>Measurement:</p>		<p style="text-align: center;">NA</p> <p>Photo #:</p>	<ul style="list-style-type: none"> • Lower shelf and/or dispensing device • •
<p>2.83 If there is a shallow obstruction no deeper than 10 inches with a parallel approach, is the shelf or dispensing device no higher than 48 inches above the floor?</p>	<p><input type="checkbox"/> Yes <input type="checkbox"/> No</p> <p>Measurement:</p>		<p style="text-align: center;">NA</p> <p>Photo #:</p>	<ul style="list-style-type: none"> • Lower shelf and/or dispensing device • •
<p>2.84 If there is an obstruction no less than 10 inches and no greater than 24 inches deep with a parallel approach, is the shelf or dispensing device no higher than 46 inches above the floor?</p>	<p><input type="checkbox"/> Yes <input type="checkbox"/> No</p> <p>Measurement:</p>		<p style="text-align: center;">NA</p> <p>Photo #:</p>	<ul style="list-style-type: none"> • Lower shelf and/or dispensing device • •
<p>2.85 If there is an unobstructed forward approach, is the shelf or dispensing device no higher than 48 inches above the floor?</p>	<p><input type="checkbox"/> Yes <input type="checkbox"/> No</p> <p>Measurement:</p>		<p style="text-align: center;">NA</p> <p>Photo #:</p>	<ul style="list-style-type: none"> • Lower shelf and/or dispensing device • •

<p>2.86 If there is an obstruction no deeper than 20 inches with a forward approach:</p> <p>Does clear floor space extend under the obstruction that is at least the same depth as the obstruction?</p> <p>Is the shelf or dispensing device no higher than 48 inches above the floor?</p>	<p><input type="checkbox"/> Yes <input type="checkbox"/> No Measurement:</p> <p><input type="checkbox"/> Yes <input type="checkbox"/> No Measurement:</p>		<p style="text-align: center;">NA</p> <p>Photo #:</p>	<ul style="list-style-type: none"> • Reconfigure to provide knee space • Lower shelf and/or dispensing device •
<p>2.87 If the obstruction is no less than 20 inches and no greater than 25 inches deep with a forward approach:</p> <p>Does clear floor space extend under the obstruction that is at least the same depth as the obstruction?</p> <p>Is the shelf or dispensing device no higher than 44 inches above the floor?</p>	<p><input type="checkbox"/> Yes <input type="checkbox"/> No Measurement:</p> <p><input type="checkbox"/> Yes <input type="checkbox"/> No Measurement:</p>		<p style="text-align: center;">NA</p> <p>Photo #:</p>	<ul style="list-style-type: none"> • Reconfigure to provide knee space • Lower shelf and/or dispensing device •
<p>2.88 If there is a tray slide, is the top no less than 28 inches and no greater than 34 inches above the floor?</p>	<p><input type="checkbox"/> Yes <input type="checkbox"/> No Measurement:</p>		<p style="text-align: center;">NA</p> <p>Photo #:</p>	<ul style="list-style-type: none"> • Reconfigure • •

The ADA Checklist for Readily Achievable Barrier Removal

Priority 3 – Men's Toilet Rooms



Project **SDDOT Rest Area Improvements**
FHU Reference Number 13-039-01
TSP Project Number 03120855

Building **VALLEY SPRINGS**

Location **90 W., MRM 412**

Date **09-18-2013 (Inspection)**

Surveyors **Timothy Roach, AIA**
Todd Schultz, PE

Robert King, CPD

Contact Information **TSP – (605) 343-6102**

When toilet rooms are open to the public they should be accessible to people with disabilities.





Institute for Human Centered Design
www.HumanCenteredDesign.org

November 2011



ADA National Network
Questions on the ADA 800-949-4232 voice/tty
www.ADAchecklist.org

Priority 3 – Toilet Rooms		Comments	Possible Solutions
<p>3.1 If toilet rooms are available to the public, is at least one toilet room accessible? (Either one for each sex, or one unisex.)</p> <p><input checked="" type="checkbox"/> Yes <input type="checkbox"/> No</p>		<p>Photo #: 3.5</p>	<ul style="list-style-type: none"> • Reconfigure toilet rooms • Combine toilet rooms to create one unisex accessible toilet room •
<p>3.2 Are there signs at inaccessible toilet rooms that give directions to accessible toilet rooms?</p> <p><input type="checkbox"/> Yes <input type="checkbox"/> No</p>		<p>Photo #: NA</p>	<ul style="list-style-type: none"> • Install signs • •
<p>3.3 If not all toilet rooms are accessible, is there a sign at the accessible toilet room with the International Symbol of Accessibility?</p> <p><input type="checkbox"/> Yes <input type="checkbox"/> No</p>		<p>Photo #: NA</p>	<ul style="list-style-type: none"> • Install sign • •
<p>Accessible Route (2010 Standards – Chapter 4)</p>			
<p>3.4 Is there a route to the accessible toilet room(s) that does not include the use of stairs?</p> <p><input checked="" type="checkbox"/> Yes <input type="checkbox"/> No</p>			<ul style="list-style-type: none"> • Alter route • •
<p>Is the route accessible? (See Priority 2 Interior Accessible Route for specifics.)</p> <p><input checked="" type="checkbox"/> Yes <input type="checkbox"/> No</p>		<p>Photo #: 3.4</p>	

Signs at Toilet Rooms (2010 Standards – 703)

3.5 Do text characters contrast with their backgrounds?

Yes No

Are text characters raised?

Yes No

Is there Braille?

Yes No

Is the sign mounted:
On the wall on the latch side of the door?

Yes No

Note:

Signs are permitted on the push side of doors with closers and without hold-open devices.

With clear floor space beyond the arc of the door swing and 45-degree open position, at least 18 x 18 inches centered on the tactile characters? *

Yes No

Measurement:

NA

So the baseline of the lowest character is at least 48 inches above the floor and the baseline of the highest character is no more than 60 inches above the floor? *

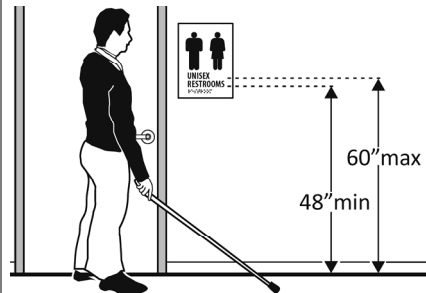
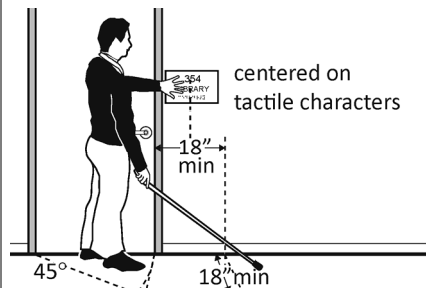
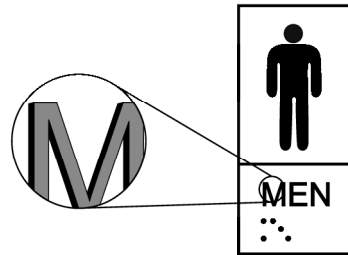
Yes No

Measurement:

NA

Note:

If the sign is at double doors with one active leaf, the sign should be on the inactive leaf; if both leaves are active, the sign

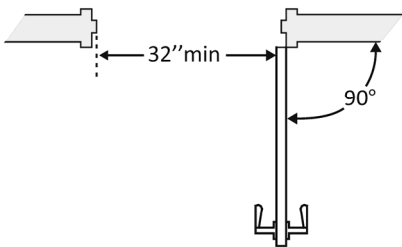
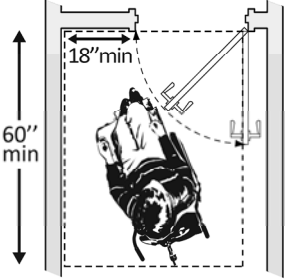
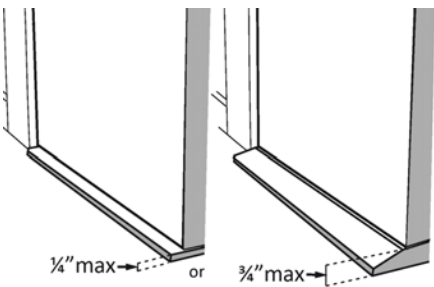


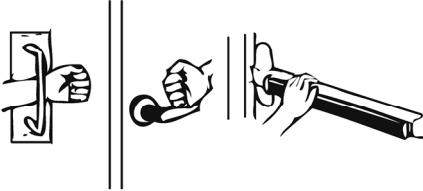
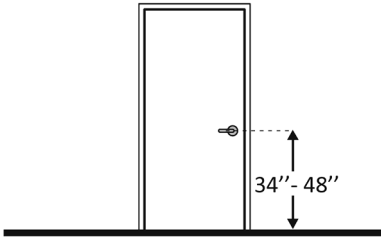

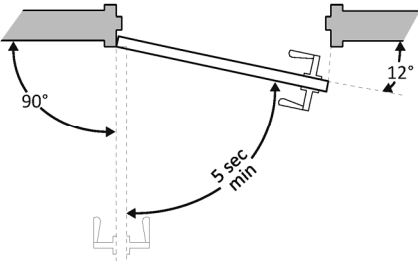
- Install tactile sign
- Relocate sign
-

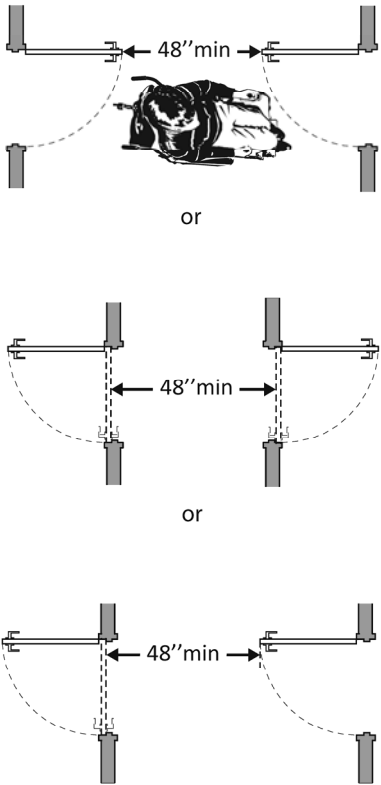
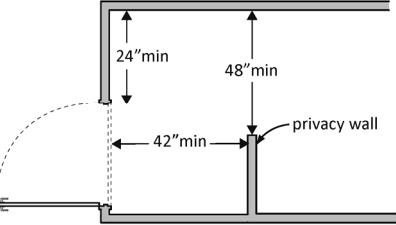
*If constructed before 3/15/2010 and a person may approach within 3 inches of the sign without encountering protruding objects or standing within the door swing, relocation not required

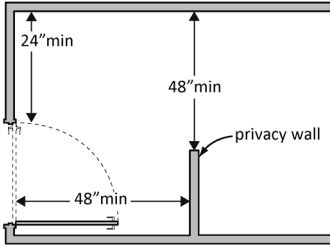

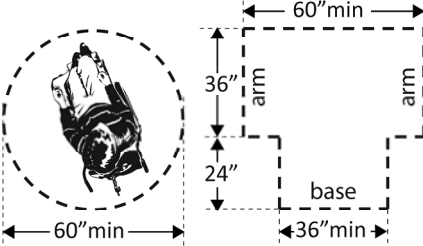
*If constructed before 3/15/2012 and mounted no higher than 60 inches to the centerline of the sign, relocation is not required

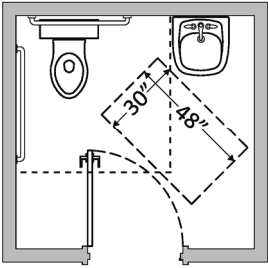
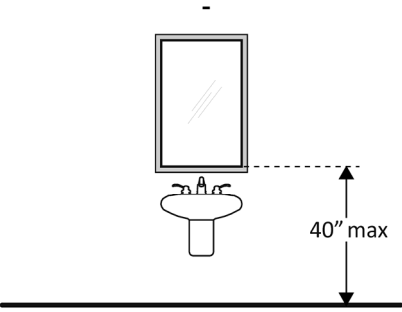
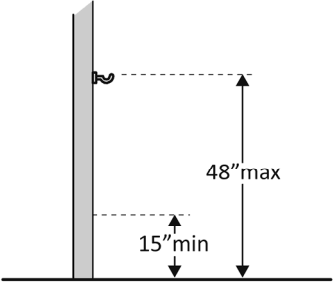
Photo #: 3.5

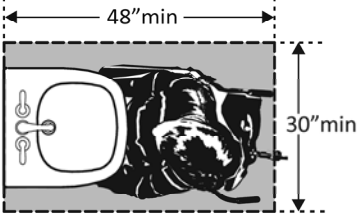
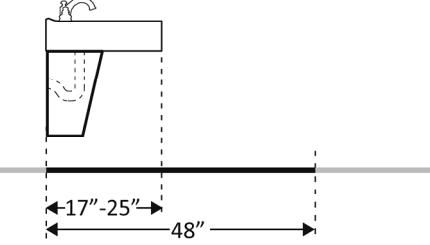
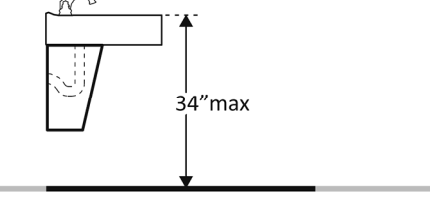
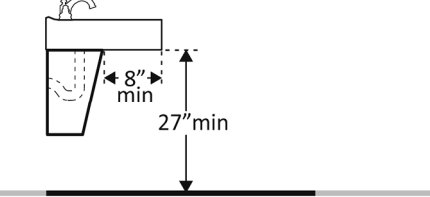
<p>should be on the wall to the right of the right leaf.</p>				
<p>Entrance (2010 Standards – 404)</p>				
<p>3.6 Is the door opening width at least 32 inches clear, between the face of the door and the stop, when the door is open 90 degrees?</p>	<p><input checked="" type="checkbox"/> Yes <input type="checkbox"/> No</p> <p>Measurement:</p> <p>33"</p>		<p>Photo #: 3.6</p>	<ul style="list-style-type: none"> • Install offset hinges • Alter the doorway •
<p>3.7 If there is a front approach to the pull side of the door is there at least 18 inches of maneuvering clearance beyond the latch side plus 60 inches clear depth?</p> <p>On both sides of the door, is the floor surface of the maneuvering clearance level (no steeper than 1:48)?</p>	<p><input type="checkbox"/> Yes <input checked="" type="checkbox"/> No</p> <p>Measurement:</p> <p>22" X 41"</p> <p><input checked="" type="checkbox"/> Yes <input type="checkbox"/> No</p> <p>Measurement:</p>		<p>Photo #: 3.1</p>	<ul style="list-style-type: none"> • Remove obstructions • Reconfigure walls • Add automatic door opener <p>See 2010 Standards 404.2.4 for maneuvering clearance requirements on the push side of the door and side approaches to the pull side of the door</p>
<p>3.8 Is the door threshold edge no more than ¼ inch high?</p> <p>Or</p> <p>No more than ¾ inch high if slope is beveled no steeper than 1:2?</p> <p>Note: The first ¼ inch of the threshold may be vertical; the rest must be beveled.</p>	<p><input type="checkbox"/> Yes <input type="checkbox"/> No</p> <p>Measurement:</p> <p><input type="checkbox"/> Yes <input type="checkbox"/> No</p> <p>Measurement:</p>		<p>NA</p> <p>Photo #:</p>	<ul style="list-style-type: none"> • Remove or replace threshold • •

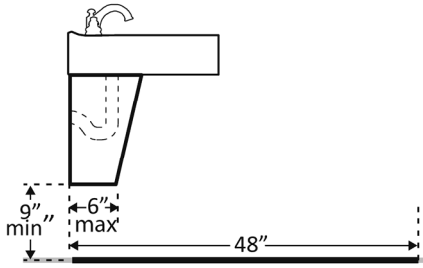
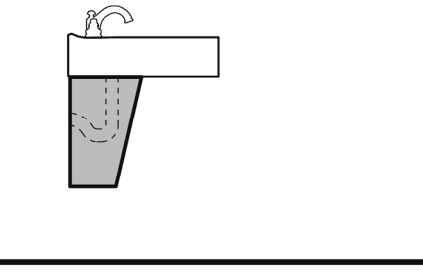
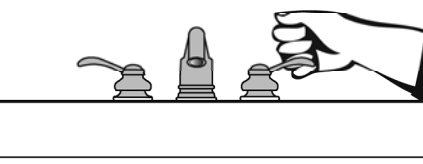
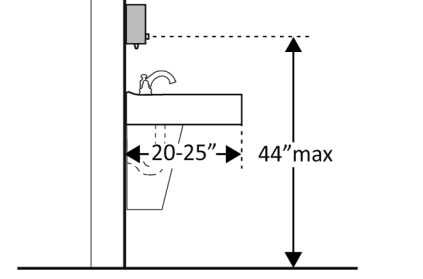
<p>3.9 Is the door equipped with hardware that is operable with one hand and does not require tight grasping, pinching, or twisting of the wrist? Check door handle and lock (if provided).</p>	<p><input checked="" type="checkbox"/> Yes <input type="checkbox"/> No</p> <p>Measurement:</p>		<p>Photo #: 3.9</p>	<ul style="list-style-type: none"> • Replace knobs or latches with lever or loop handles • Install power-assisted or automatic door openers •
<p>3.10 Are the operable parts of the door hardware mounted no less than 34 inches and no greater than 48 inches above the floor?</p>	<p><input type="checkbox"/> Yes <input checked="" type="checkbox"/> No</p> <p>Measurement: 39 ½ BOTTOM 50 ½ TOP</p>		<p>Photo #: 3.9</p>	<ul style="list-style-type: none"> • Change hardware height • •
<p>3.11 Can the door be opened easily (5 pounds maximum force)?</p>	<p><input type="checkbox"/> Yes <input checked="" type="checkbox"/> No</p> <p>Measurement: 10LB</p>		<p>Photo #: 3.11</p>	<ul style="list-style-type: none"> • Adjust or replace closers • Install lighter doors • Install power-assisted or automatic door openers
<p>3.12 If the door has a closer, does it take at least 5 seconds to close from an open position of 90 degrees to a position of 12 degrees from the latch?</p>	<p><input type="checkbox"/> Yes <input checked="" type="checkbox"/> No</p> <p>Measurement: 3 SEC.</p>		<p>Photo #: 3.11</p>	<ul style="list-style-type: none"> • Adjust closer • •

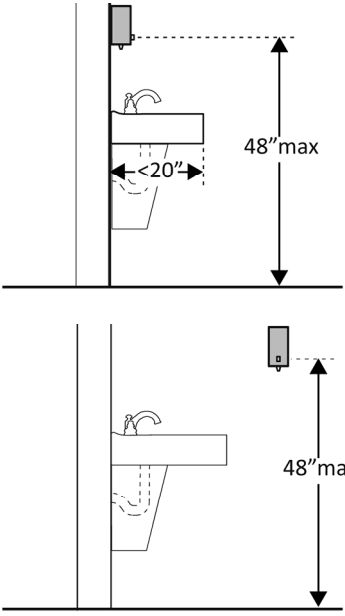
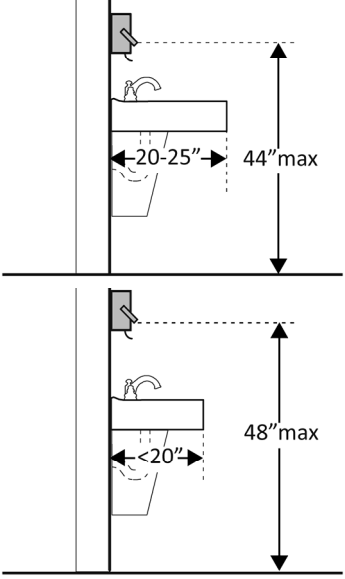
<p>3.13 If there are two doors in a series, e.g. vestibule, is the distance between the doors at least 48 inches plus the width of the doors when swinging into the space?</p>	<p><input type="checkbox"/> Yes <input type="checkbox"/> No</p> <p>Measurement:</p>		<p style="text-align: center; color: red; font-weight: bold;">NA</p> <p>Photo #:</p>	<ul style="list-style-type: none"> • Remove inner door • Change door swing •
<p>3.14 If there is a privacy wall and the door swings out, is there at least 24 inches of maneuvering clearance beyond the door latch side and 42 inches to the privacy wall?</p>	<p><input type="checkbox"/> Yes <input type="checkbox"/> No</p> <p>Measurement:</p>		<p style="text-align: center; color: red; font-weight: bold;">NA</p> <p>Photo #:</p>	<ul style="list-style-type: none"> • Reconfigure space • •

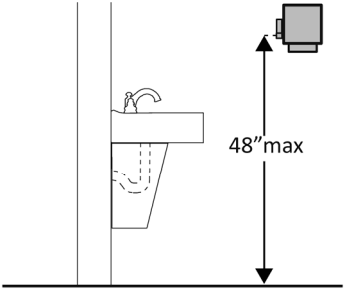
<p>3.15 If there is a privacy wall and the door swings in, is there at least 24 inches of maneuvering clearance beyond the door latch side and at least 48 inches to the privacy wall if there is no door closer or at least 54 inches if there is a door closer?</p>	<p><input type="checkbox"/> Yes <input type="checkbox"/> No</p> <p>Measurement:</p>		<p style="text-align: center; color: red; font-weight: bold;">NA</p> <p>Photo #:</p>	<ul style="list-style-type: none"> • Reconfigure space • •
In the Toilet Room				
<p>3.16 Is there a clear path to at least one of each type of fixture, e.g. lavatory, hand dryer, etc., that is at least 36 inches wide?</p>	<p><input checked="" type="checkbox"/> Yes <input type="checkbox"/> No</p> <p>Measurement:</p> <p style="color: red; font-weight: bold; text-align: center;">38"</p>		<p>Photo #: 3.16</p>	<ul style="list-style-type: none"> • Remove obstructions • •
<p>3.17 Is there clear floor space available for a person in a wheelchair to turn around, i.e. a circle at least 60 inches in diameter or a T-shaped space within a 60-inch square?*</p>	<p><input checked="" type="checkbox"/> Yes <input type="checkbox"/> No</p> <p>Measurement:</p> <p style="color: red; font-weight: bold; text-align: center;">61" x 31" at Lavs</p>		<p>Photo #: 3.17</p>	<p>*The door to the toilet room may swing into the required turning space</p> <ul style="list-style-type: none"> • Move or remove partitions, fixtures or objects such as trash cans • •

<p>3.18 In a single user toilet room if the door swings in and over a clear floor space at an accessible fixture, is there a clear floor space at least 30 x 48 inches beyond the swing of the door?</p>	<p><input type="checkbox"/> Yes <input type="checkbox"/> No</p> <p>Measurement:</p>		<p style="text-align: center;">NA</p> <p>Photo #:</p>	<ul style="list-style-type: none"> • Reverse door swing • Alter toilet room •
<p>3.19 If the mirror is over a lavatory or countertop, is the bottom edge of the reflecting surface no higher than 40 inches above the floor? Or If the mirror is not over the lavatory or countertop, is the bottom edge of the reflecting surface no higher than 35 inches above the floor?*</p>	<p><input checked="" type="checkbox"/> Yes <input type="checkbox"/> No</p> <p>Measurement:</p> <p style="text-align: center;">40"</p> <p><input type="checkbox"/> Yes <input type="checkbox"/> No</p> <p>Measurement:</p> <p style="text-align: center;">NA</p>		<p>Photo #: 3.19</p>	<p>* If installed before 3/15/2012 and the bottom edge of the reflecting surface is no higher than 40 inches above the floor, lowering the mirror to 35 inches is not required</p> <ul style="list-style-type: none"> • Lower the mirror • Add another mirror •
<p>3.20 If there is a coat hook, is it no less than 15 inches and no greater than 48 inches above the floor?</p>	<p><input type="checkbox"/> Yes <input type="checkbox"/> No</p> <p>Measurement:</p>		<p style="text-align: center;">NA</p> <p>Photo #:</p>	<ul style="list-style-type: none"> • Adjust hook • Replace with or provide additional accessible hook •

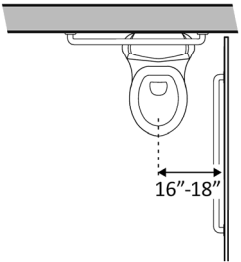
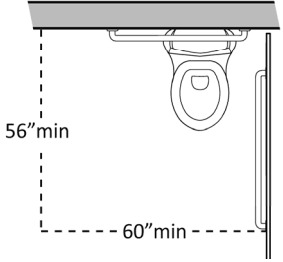
Lavatories (2010 Standards – 606) Note: 2010 Standards refer to sinks in toilet rooms as lavatories.				
<p>3.21 Does at least one lavatory have a clear floor space for a forward approach at least 30 inches wide and 48 inches long?</p>	<p><input checked="" type="checkbox"/> Yes <input type="checkbox"/> No</p> <p>Measurement:</p> <p>61" x 39"</p>	 <p>48" min</p> <p>30" min</p>	<p>Photo #: 3.17</p>	<ul style="list-style-type: none"> • Alter lavatory • Replace lavatory •
<p>3.22 Do no less than 17 inches and no greater than 25 inches of the clear floor space extend under the lavatory so that a person using a wheelchair can get close enough to reach the faucet?</p>	<p><input checked="" type="checkbox"/> Yes <input type="checkbox"/> No</p> <p>Measurement:</p> <p>25"</p>	 <p>17"-25"</p> <p>48"</p>	<p>Photo #: 3.17</p>	<ul style="list-style-type: none"> • Alter lavatory • Replace lavatory •
<p>3.23 Is the front of the lavatory or counter surface, whichever is higher, no more than 34 inches above the floor?</p>	<p><input type="checkbox"/> Yes <input checked="" type="checkbox"/> No</p> <p>Measurement:</p> <p>36 1/2"</p>	 <p>34" max</p>	<p>Photo #: 3.23</p>	<ul style="list-style-type: none"> • Alter lavatory • Replace lavatory •
<p>3.24 Is there at least 27 inches clearance from the floor to the bottom of the lavatory that extends at least 8 inches under the lav for knee clearance?</p>	<p><input checked="" type="checkbox"/> Yes <input type="checkbox"/> No</p> <p>Measurement:</p> <p>30 1/2"</p>	 <p>8" min</p> <p>27" min</p>	<p>Photo #: 3.23</p>	<ul style="list-style-type: none"> • Alter lavatory • Replace lavatory •

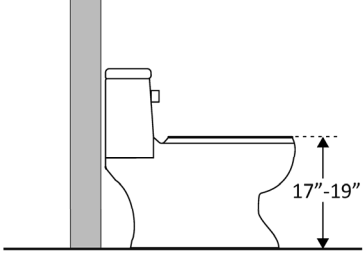
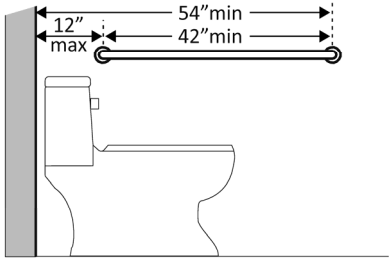
<p>3.25 Is there toe clearance at least 9 inches high? (Space extending greater than 6 inches beyond the available toe clearance at 9 inches above the floor is not considered toe clearance.)</p>	<p><input checked="" type="checkbox"/> Yes <input type="checkbox"/> No</p>		<p>Photo #:</p>	<ul style="list-style-type: none"> • Alter lavatory • Replace lavatory •
<p>3.26 Are pipes below the lavatory insulated or otherwise configured to protect against contact?</p>	<p><input type="checkbox"/> Yes <input checked="" type="checkbox"/> No</p>		<p>Photo #: 3.25</p>	<ul style="list-style-type: none"> • Install insulation • Install cover panel •
<p>3.27 Can the faucet be operated without tight grasping, pinching, or twisting of the wrist? Is the force required to activate the faucet no greater than 5 pounds?</p>	<p><input checked="" type="checkbox"/> Yes <input type="checkbox"/> No</p> <p><input type="checkbox"/> Yes <input type="checkbox"/> No</p> <p>NA</p>		<p>2 lavs with sensor faucets – (one not operable)</p> <p>Photo #: 3.28</p>	<ul style="list-style-type: none"> • Adjust faucet • Replace faucet •
<p>Soap Dispensers and Hand Dryers (2010 Standards – 603)</p>				
<p>3.28 Are the operable parts of the soap dispenser within one of the following reach ranges: Above lavatories or counters no less than 20 inches and no greater than 25 inches deep: no higher than 44 inches above the floor?</p>	<p><input type="checkbox"/> Yes <input checked="" type="checkbox"/> No</p> <p>Measurement: 47"</p>		<p>Photo #:</p>	<ul style="list-style-type: none"> • Adjust dispensers • Replace with or provide additional accessible dispensers •

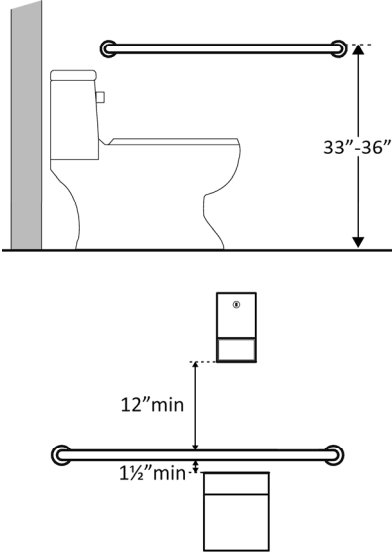
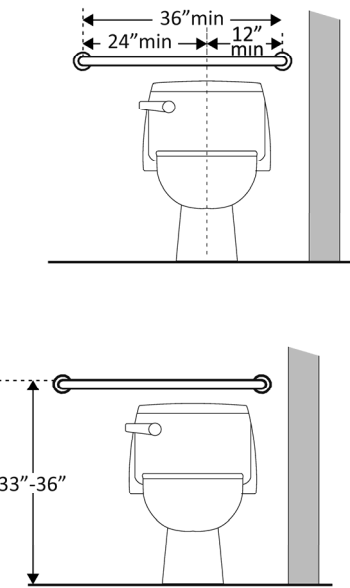
<p>Above lavatories less than 20 inches deep: no higher than 48 inches above the floor?</p> <p>Not over an obstruction: no higher than 48 inches above the floor?</p>	<p><input type="checkbox"/> Yes <input type="checkbox"/> No Measurement:</p> <p><input type="checkbox"/> Yes <input type="checkbox"/> No Measurement:</p>		<p>Photo #: 3.19</p>	
<p>3.29 Are the operable parts of the hand dryer or towel dispenser within one of the following reach ranges:</p> <p>Above lavatories or counters no less than 20 inches and no greater than 25 inches deep: no higher than 44 inches above the floor?</p> <p>Above lavatories less than 20 inches deep: no higher than 48 inches above the floor?</p> <p>Not over an obstruction: no higher than 48 inches above the floor?</p>	<p><input type="checkbox"/> Yes <input type="checkbox"/> No Measurement:</p> <p><input type="checkbox"/> Yes <input type="checkbox"/> No Measurement:</p> <p><input checked="" type="checkbox"/> Yes <input type="checkbox"/> No Measurement:</p>			<ul style="list-style-type: none"> • Adjust dispensers • Replace with or provide additional accessible dispensers •

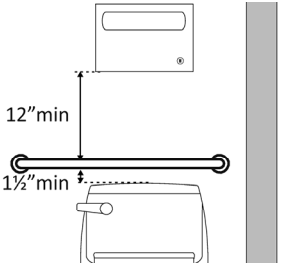
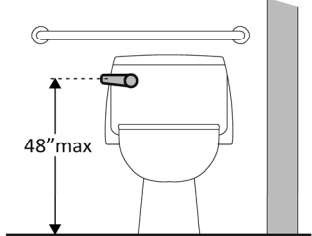
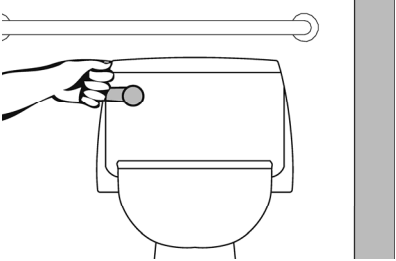
<p>Can the operable parts of the hand dryer or towel dispenser be operated without tight grasping, pinching or twisting of the wrist?</p> <p>Is the force required to activate the hand dryer or towel dispenser no greater than 5 pounds?</p>	<p>42"</p> <p><input checked="" type="checkbox"/> Yes <input type="checkbox"/> No</p> <p><input checked="" type="checkbox"/> Yes <input type="checkbox"/> No</p> <p>Measurement: 3lbs</p>		<p>Photo #: 3.29</p>	
--	---	--	-----------------------------	--

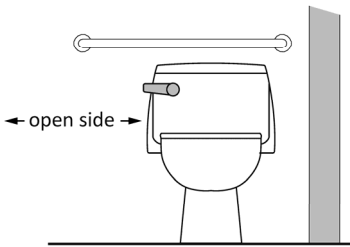
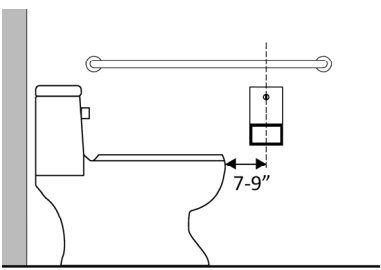
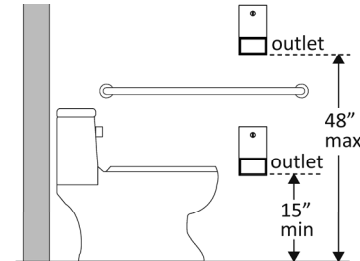
Water Closets in Single-User Toilet Rooms and Compartments (Stalls) (2010 Standards – 603 & 609) Note: 2010 Standards refer to toilets as water closets.

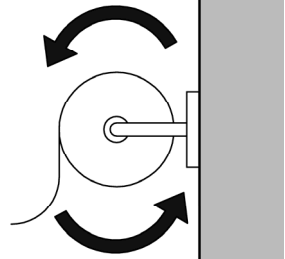
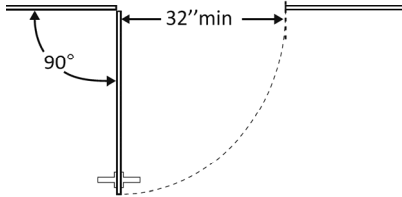
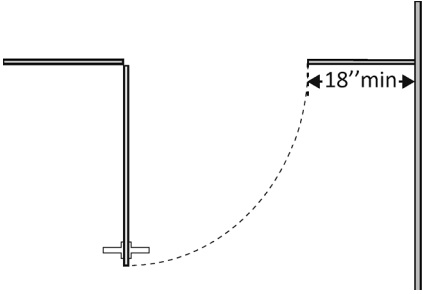
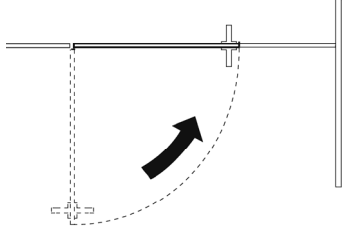
<p>3.30 Is the centerline of the water closet no less than 16 inches and no greater than 18 inches from the side wall or partition?</p>	<p><input type="checkbox"/> Yes <input checked="" type="checkbox"/> No</p> <p>Measurement: 20"</p>		<p>Photo #: 3.30</p>	<ul style="list-style-type: none"> • Move toilet • Replace toilet • Move partition •
<p>3.31 Is clearance provided around the water closet measuring at least 60 inches from the side wall and at least 56 inches from the rear wall?*</p>	<p><input type="checkbox"/> Yes <input checked="" type="checkbox"/> No</p> <p>Measurement: 67 ½" x 41 ½"</p>			<p>* If constructed before 3/15/12, clearances around water closets in single user toilet rooms can be 48 inches wide by 66 inches long or 48 inches wide by 56 inches long (depending on the approach to the water closet, see 1991 Standards Figure 28) and the lavatory may overlap that clearance if the door to the room does</p>

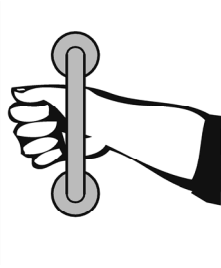
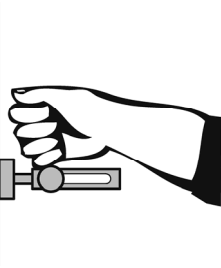
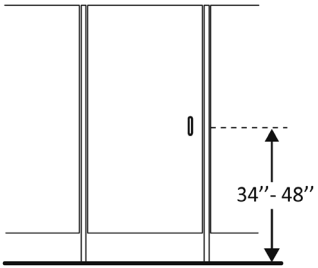
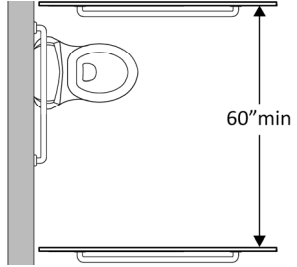
			<p>Photo #: 3.30</p>	<p>not swing into the required clearances at fixtures (such as lavatories, water closet and urinals) and the edge of the lavatory is at least 18 inches from the centerline of the water closet</p> <ul style="list-style-type: none"> Alter room/compartment for clearance
<p>3.32 Is the height of the water closet no less than 17 inches and no greater than 19 inches above the floor measured to the top of the seat?</p>	<p><input checked="" type="checkbox"/> Yes <input type="checkbox"/> No</p> <p>Measurement: 18"</p>		<p>Photo #: 3.30</p>	<ul style="list-style-type: none"> Adjust toilet height Replace toilet
<p>3.33 Is there a grab bar at least 42 inches long on the side wall?</p> <p>Is it located no more than 12 inches from the rear wall?</p> <p>Does it extend at least 54 inches from the rear wall?</p> <p>Is it mounted no less than 33 inches and no greater than 36</p>	<p><input type="checkbox"/> Yes <input checked="" type="checkbox"/> No</p> <p>Measurement: 32"</p> <p><input checked="" type="checkbox"/> Yes <input type="checkbox"/> No</p> <p>Measurement: ATTACHED TO WALL</p> <p><input type="checkbox"/> Yes <input checked="" type="checkbox"/> No</p> <p>Measurement: 32"</p> <p><input type="checkbox"/> Yes <input checked="" type="checkbox"/> No</p>			<ul style="list-style-type: none"> Install grab bar Relocate grab bar Relocate objects

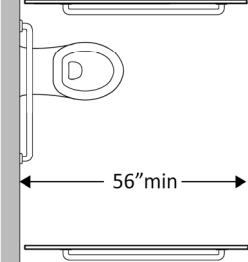
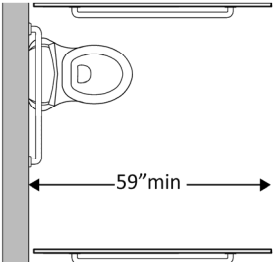
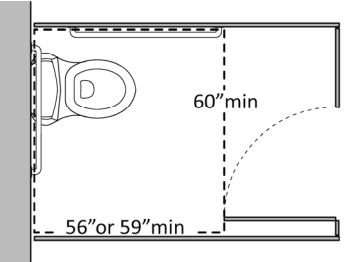
<p>inches above the floor to the top of the gripping surface?</p> <p>Is there at least 12 inches clearance between the grab bar and protruding objects above?*</p> <p>Is there at least 1½ inches clearance between the grab bar and projecting objects below?*</p> <p>Is the space between the wall and the grab bar 1 ½ inches?</p>	<p>Measurement: 30"</p> <p><input type="checkbox"/> Yes <input checked="" type="checkbox"/> No</p> <p>Measurement: 3 ½" TO PAPER DISPENSER</p> <p><input checked="" type="checkbox"/> Yes <input type="checkbox"/> No</p> <p>Measurement: 29 ½"</p> <p><input checked="" type="checkbox"/> Yes <input type="checkbox"/> No</p> <p>Measurement: 1 ½" RIGHT SIDE 1 ½" LEFT SIDE</p>		<p>Photo #: 3.30</p>	<p>* If constructed before 3/15/2012 grab bars do not need to be relocated; there are no space requirements above and below grab bars in the 1991 Standards</p>
<p>3.34 Is there a grab bar at least 36 inches long on the rear wall?</p> <p>Does it extend at least 12 inches from the centerline of the water closet on one side (side wall)?</p> <p>Does it extend at least 24 inches on the other (open) side?</p> <p>Is it mounted no less than 33 inches and no greater than 36 inches above the floor to the top of the gripping surface?</p> <p>Are there at least 12 inches</p>	<p><input type="checkbox"/> Yes <input checked="" type="checkbox"/> No</p> <p>Measurement: 24"</p> <p><input checked="" type="checkbox"/> Yes <input type="checkbox"/> No</p> <p>Measurement: 12"</p> <p><input type="checkbox"/> Yes <input checked="" type="checkbox"/> No</p> <p>Measurement: 12"</p> <p><input checked="" type="checkbox"/> Yes <input type="checkbox"/> No</p> <p>Measurement: 34"</p> <p><input type="checkbox"/> Yes <input type="checkbox"/> No</p>		<p>Photo #: 3.30</p> <p>Photo #: 3.30</p>	<ul style="list-style-type: none"> • Install grab bar • Relocate grab bar • Relocate objects •

<p>clearance between the grab bar and protruding objects above?*</p> <p>Are there at least 1½ inches clearance between the grab bar and projecting objects below?*</p> <p>Is the space between the wall and the grab bar 1 ½ inches?</p>	<p>Measurement: NA</p> <p><input type="checkbox"/> Yes <input checked="" type="checkbox"/> No</p> <p>Measurement: 1" TO FLUSH VALVE</p> <p><input type="checkbox"/> Yes <input type="checkbox"/> No</p> <p>Measurement:</p>		<p>Photo #: 3.30</p>	<p>* If constructed before 3/15/2012 grab bars do not need to be relocated; there are no space requirements above and below grab bars in the 1991 Standards</p>
<p>3.35 If the flush control is hand operated, is the operable part located no higher than 48 inches above the floor?</p>	<p><input type="checkbox"/> Yes <input type="checkbox"/> No</p> <p>Measurement: NA</p>		<p>SENSOR OPERATED</p> <p>Photo #:</p>	<ul style="list-style-type: none"> • Move control • Install sensor with override button no higher than 48 inches •
<p>3.36 If the flush control is hand operated, can it be operated with one hand and without tight grasping, pinching, or twisting of the wrist?</p> <p>Is the force required to activate the flush control no greater than 5 pounds?</p>	<p><input type="checkbox"/> Yes <input type="checkbox"/> No</p> <p><input type="checkbox"/> Yes <input type="checkbox"/> No</p> <p>Measurement:</p>		<p>NA</p> <p>Photo #:</p>	<ul style="list-style-type: none"> • Change control • Adjust control •

<p>3.37 Is the flush control on the open side of the water closet?</p>	<p><input type="checkbox"/> Yes <input type="checkbox"/> No</p>		<p style="text-align: center; color: red; font-weight: bold;">NA</p> <p>Photo #:</p>	<ul style="list-style-type: none"> • Move control • •
<p>3.38 Is the toilet paper dispenser located no less than 7 inches and no greater than 9 inches from the front of the water closet to the centerline of the dispenser?*</p>	<p><input type="checkbox"/> Yes <input checked="" type="checkbox"/> No</p> <p>Measurement:</p> <p style="text-align: center; color: red; font-weight: bold;">3"</p>		<p>Photo #: 3.30</p>	<p>* If constructed before 3/15/2012 dispenser does not need to be relocated if it is within reach from the water closet seat; the 1991 Standards do not specify distance from the front of the water closet</p> <ul style="list-style-type: none"> • Relocate dispenser • •
<p>3.39 Is the outlet of the dispenser:</p> <p>Located no less than 15 inches and no greater than 48 inches above the floor?</p> <p>Not located behind grab bars?</p>	<p><input checked="" type="checkbox"/> Yes <input type="checkbox"/> No</p> <p>Measurement:</p> <p style="text-align: center; color: red; font-weight: bold;">35"</p> <p><input type="checkbox"/> Yes <input checked="" type="checkbox"/> No</p>		<p>Photo #: 3.28</p>	<ul style="list-style-type: none"> • Relocate dispenser • •

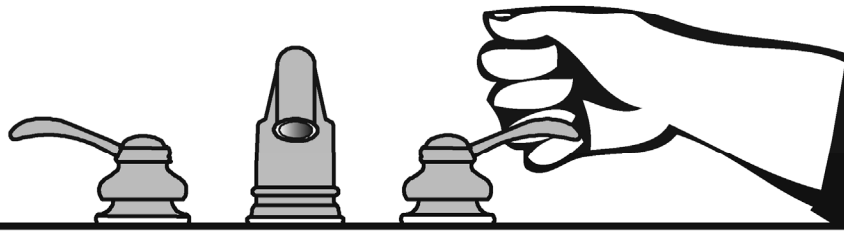
<p>3.40 Does the dispenser allow continuous paper flow?</p>	<p><input checked="" type="checkbox"/> Yes <input type="checkbox"/> No</p>		<p>Photo #: 3.28</p>	<ul style="list-style-type: none"> • Adjust dispenser • Replace dispenser •
<p>Toilet Compartments (Stalls) (2010 Standards – 604)</p>				
<p>3.41 Is the door opening width at least 32 inches clear, between the face of the door and the stop, when the door is open 90 degrees?</p>	<p><input checked="" type="checkbox"/> Yes <input type="checkbox"/> No</p> <p>Measurement: 32"</p>		<p>Photo #: 3.44</p>	<ul style="list-style-type: none"> • Widen door width • •
<p>3.42 If there is a front approach to the pull side of the door, is there at least 18 inches of maneuvering clearance beyond the latch side plus 60 inches clear depth?*</p>	<p><input type="checkbox"/> Yes <input checked="" type="checkbox"/> No</p> <p>Measurement: 6" X 42"</p>		<p>Photo #: 3.44</p>	<p>*See 2010 Standards 604.8.1.2 Doors for maneuvering clearance requirements on the push side of the door and side approaches to the pull side of the door</p> <ul style="list-style-type: none"> • Remove obstructions •
<p>3.43 Is the door self-closing?</p>	<p><input type="checkbox"/> Yes <input checked="" type="checkbox"/> No</p>		<p>Photo #: 3.44</p>	<ul style="list-style-type: none"> • Add closer • Replace door •

<p>3.44 Are there door pulls on both sides of the door that are operable with one hand and do not require tight grasping pinching or twisting of the wrist?*</p>	<p><input type="checkbox"/> Yes <input checked="" type="checkbox"/> No</p>		<p>Photo #: 3.44</p>	<p>* If constructed before 3/15/2012 door pulls do not need to be added; door pulls are not required in the 1991 Standards</p> <ul style="list-style-type: none"> • Replace hardware • •
<p>3.45 Is the lock operable with one hand and without tight grasping, pinching or twisting of the wrist?</p>	<p><input type="checkbox"/> Yes <input checked="" type="checkbox"/> No</p> <p>10 LBS TO MOVE LATCH</p>		<p>Photo #: 3.44</p>	<ul style="list-style-type: none"> • Replace lock • •
<p>3.46 Are the operable parts of the door hardware mounted no less than 34 inches and no greater than 48 inches above the floor?</p>	<p><input checked="" type="checkbox"/> Yes <input type="checkbox"/> No</p> <p>Measurement:</p> <p>40"</p>		<p>Photo #: 3.44</p>	<ul style="list-style-type: none"> • Relocate hardware • •
<p>3.47 Is the compartment at least 60 inches wide?</p>	<p><input type="checkbox"/> Yes <input checked="" type="checkbox"/> No</p> <p>Measurement:</p> <p>40"</p>		<p>Photo #: 3.30</p>	<ul style="list-style-type: none"> • Widen compartment • •

<p>3.48 If the water closet is wall hung, is the compartment at least 56 inches deep?</p>	<p><input checked="" type="checkbox"/> Yes <input type="checkbox"/> No</p> <p>Measurement:</p> <p>67"</p>		<p>Photo #: 3.30</p>	<ul style="list-style-type: none"> • Widen compartment • •
<p>3.49 If the water closet is floor mounted, is the compartment at least 59 inches deep?</p>	<p><input type="checkbox"/> Yes <input type="checkbox"/> No</p> <p>Measurement:</p>		<p>Photo #: NA</p>	<ul style="list-style-type: none"> • Alter compartment • •
<p>3.50 If the door swings in, is the minimum required compartment area provided beyond the swing of the door (60 inches x 56 inches if water closet is wall hung or 59 inches if water closet is floor mounted)?</p>	<p><input type="checkbox"/> Yes <input type="checkbox"/> No</p> <p>Measurement:</p>		<p>Photo #: NA</p>	<ul style="list-style-type: none"> • Reverse door swing • Alter compartment •
	<p><input type="checkbox"/> Yes <input type="checkbox"/> No</p>		<p>Photo #:</p>	<ul style="list-style-type: none"> • • •
	<p><input type="checkbox"/> Yes <input type="checkbox"/> No</p>		<p>Photo #:</p>	<ul style="list-style-type: none"> • • •

The ADA Checklist for Readily Achievable Barrier Removal

Priority 3 – Women’s Toilet Rooms



Project **SDDOT Rest Area Improvements**
FHU Reference Number 13-039-01
TSP Project Number 03120855

Building **VALLEY SPRINGS**

Location **90 W., MRM 412**

Date **09-18-2013 (Inspection)**

Surveyors **Timothy Roach, AIA**
Todd Schultz, PE

Robert King, CPD

Contact Information **TSP – (605) 343-6102**



When toilet rooms are open to the public they should be accessible to people with disabilities.



Institute for Human Centered Design
www.HumanCenteredDesign.org
November 2011



ADA National Network
Questions on the ADA 800-949-4232 voice/tty
www.ADAchecklist.org

Priority 3 – Toilet Rooms		Comments	Possible Solutions
<p>3.1 If toilet rooms are available to the public, is at least one toilet room accessible? (Either one for each sex, or one unisex.)</p> <p><input checked="" type="checkbox"/> Yes <input type="checkbox"/> No</p>		Photo #: 3.7	<ul style="list-style-type: none"> • Reconfigure toilet rooms • Combine toilet rooms to create one unisex accessible toilet room
<p>3.2 Are there signs at inaccessible toilet rooms that give directions to accessible toilet rooms?</p> <p><input type="checkbox"/> Yes <input type="checkbox"/> No</p>		<p>NA</p> <p>Photo #:</p>	<ul style="list-style-type: none"> • Install signs • •
<p>3.3 If not all toilet rooms are accessible, is there a sign at the accessible toilet room with the International Symbol of Accessibility?</p> <p><input type="checkbox"/> Yes <input type="checkbox"/> No</p>		<p>NA</p> <p>Photo #:</p>	<ul style="list-style-type: none"> • Install sign • •
<p>Accessible Route (2010 Standards – Chapter 4)</p>			
<p>3.4 Is there a route to the accessible toilet room(s) that does not include the use of stairs?</p> <p><input checked="" type="checkbox"/> Yes <input type="checkbox"/> No</p>		Photo #: 3.4	<ul style="list-style-type: none"> • Alter route • •
<p>Is the route accessible? (See Priority 2 Interior Accessible)</p> <p><input checked="" type="checkbox"/> Yes <input type="checkbox"/> No</p>			

Route for specifics.)

Signs at Toilet Rooms (2010 Standards – 703)

3.5 Do text characters contrast with their backgrounds?

Yes No

Are text characters raised?

Yes No

Is there Braille?

Yes No

Is the sign mounted:
On the wall on the latch side of the door?

Yes No

Note:

Signs are permitted on the push side of doors with closers and without hold-open devices.

With clear floor space beyond the arc of the door swing between the closed position and 45-degree open position, at least 18 x 18 inches centered on the tactile characters? *

Yes No

Measurement:

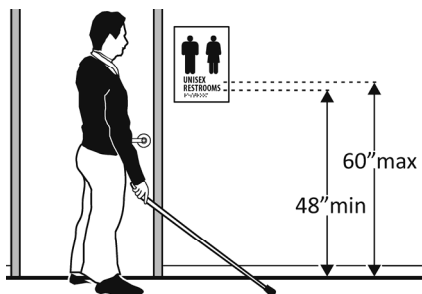
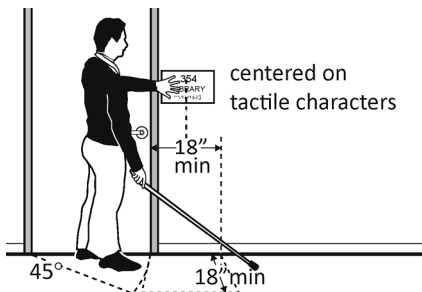
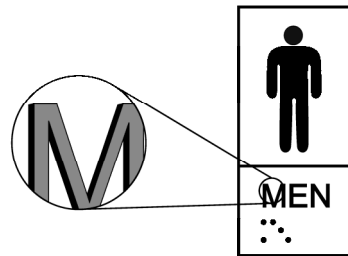
NA

So the baseline of the lowest character is at least 48 inches above the floor and the baseline of the highest character is no more than 60 inches above the floor? *

Yes No

Measurement:

NA



- Install tactile sign
- Relocate sign
-

*If constructed before 3/15/2010 and a person may approach within 3 inches of the sign without encountering protruding objects or standing within the door swing, relocation not required

*If constructed before 3/15/2012 and mounted no higher than 60 inches to the centerline of the sign, relocation is not required

Note:

If the sign is at double doors with one active leaf, the sign should be on the inactive leaf; if both leaves are active, the sign should be on the wall to the right of the right leaf.

Photo #: **3.7**

Entrance (2010 Standards – 404)

3.6 Is the door opening width at least 32 inches clear, between the face of the door and the stop, when the door is open 90 degrees?

Yes No

Measurement:
33"

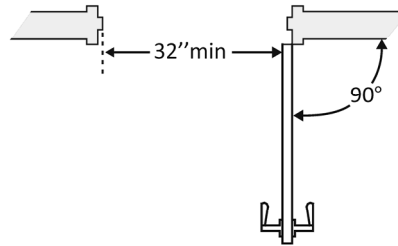


Photo #: **3.6**

- Install offset hinges
- Alter the doorway
-

3.7 If there is a front approach to the pull side of the door is there at least 18 inches of maneuvering clearance beyond the latch side plus 60 inches clear depth?

Yes No

Measurement:
Side of door 0"
63" clear depth

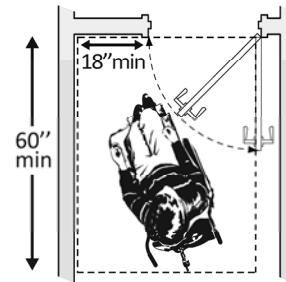
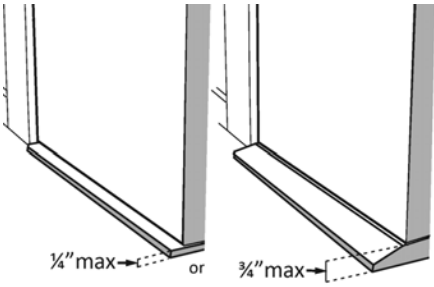
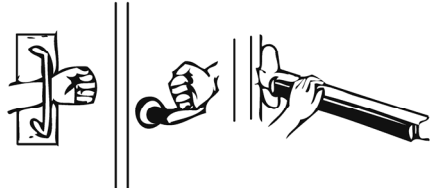
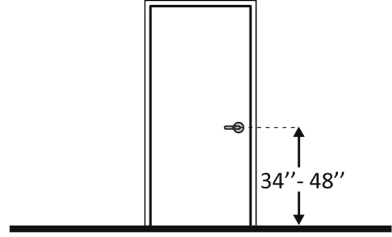

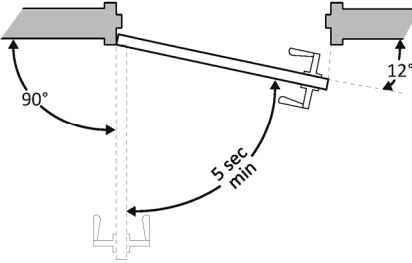
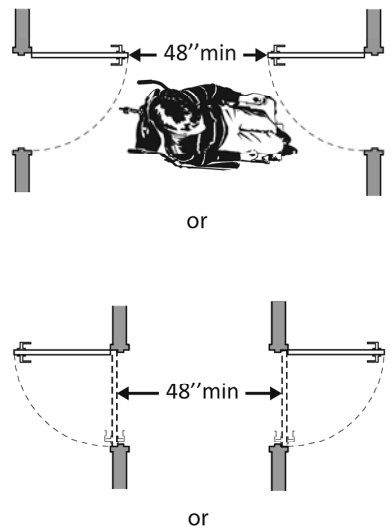


Photo #: **3.7**

- Remove obstructions
- Reconfigure walls
- Add automatic door opener

See 2010 Standards 404.2.4 for maneuvering clearance requirements on the push side of the door and side approaches to the pull side of the door

<p>3.8 Is the door threshold edge no more than ¼ inch high?</p> <p>Or</p> <p>No more than ¾ inch high if slope is beveled no steeper than 1:2?</p> <p>Note: The first ¼ inch of the threshold may be vertical; the rest must be beveled.</p>	<p><input type="checkbox"/> Yes <input type="checkbox"/> No</p> <p>Measurement:</p> <p><input type="checkbox"/> Yes <input type="checkbox"/> No</p> <p>Measurement:</p>		<p style="text-align: center;">NA</p> <p>Photo #:</p>	<ul style="list-style-type: none"> • Remove or replace threshold • •
<p>3.9 Is the door equipped with hardware that is operable with one hand and does not require tight grasping, pinching, or twisting of the wrist?</p> <p>Check door handle and lock (if provided).</p>	<p><input checked="" type="checkbox"/> Yes <input type="checkbox"/> No</p> <p>Measurement:</p>		<p>Photo #: 3.9</p>	<ul style="list-style-type: none"> • Replace knobs or latches with lever or loop handles • Install power-assisted or automatic door openers •
<p>3.10 Are the operable parts of the door hardware mounted no less than 34 inches and no greater than 48 inches above the floor?</p>	<p><input type="checkbox"/> Yes <input checked="" type="checkbox"/> No</p> <p>Measurement:</p> <p>39 ½" bottom</p> <p>50 ½" top</p>		<p>Photo #: 3.9</p>	<ul style="list-style-type: none"> • Change hardware height • •

<p>3.11 Can the door be opened easily (5 pounds maximum force)?</p>	<p><input type="checkbox"/> Yes <input checked="" type="checkbox"/> No</p> <p>Measurement:</p> <p>10 lbs.</p>		<p>Photo #: 3.11</p>	<ul style="list-style-type: none"> • Adjust or replace closers • Install lighter doors • Install power-assisted or automatic door openers
<p>3.12 If the door has a closer, does it take at least 5 seconds to close from an open position of 90 degrees to a position of 12 degrees from the latch?</p>	<p><input type="checkbox"/> Yes <input checked="" type="checkbox"/> No</p> <p>Measurement:</p> <p>3 sec.</p>		<p>Photo #: 3.11</p>	<ul style="list-style-type: none"> • Adjust closer • •
<p>3.13 If there are two doors in a series, e.g. vestibule, is the distance between the doors at least 48 inches plus the width of the doors when swinging into the space?</p>	<p><input type="checkbox"/> Yes <input type="checkbox"/> No</p> <p>Measurement:</p>		<p>NA</p>	<ul style="list-style-type: none"> • Remove inner door • Change door swing •

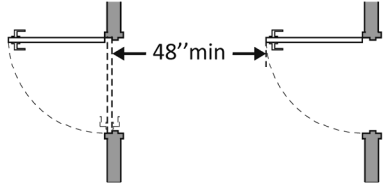
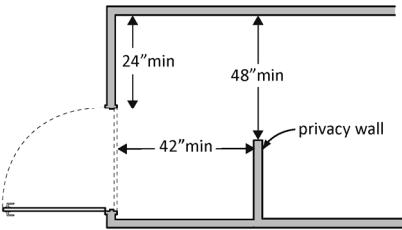
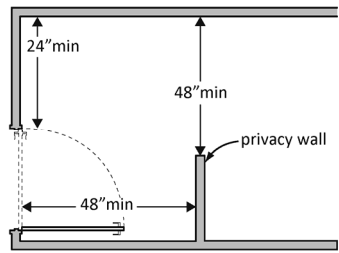

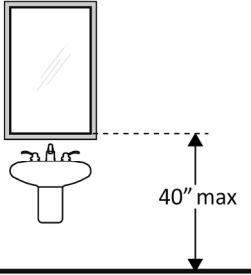
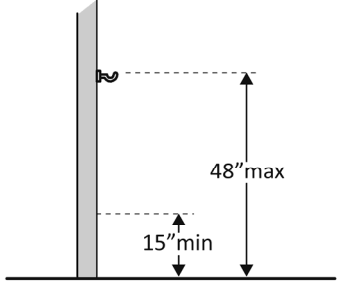
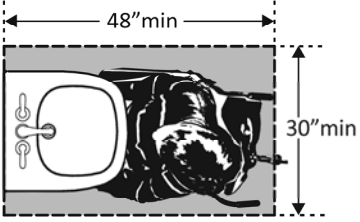
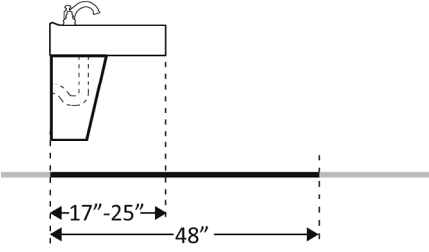
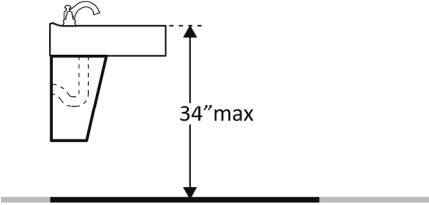
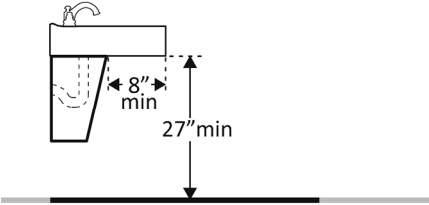
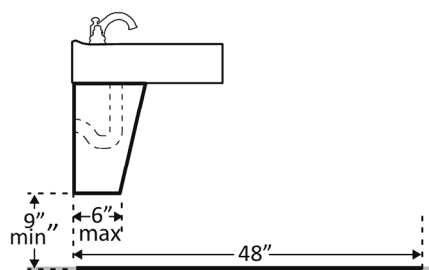
			<p>Photo #:</p>	
<p>3.14 If there is a privacy wall and the door swings out, is there at least 24 inches of maneuvering clearance beyond the door latch side and 42 inches to the privacy wall?</p>	<p><input type="checkbox"/> Yes <input type="checkbox"/> No</p> <p>Measurement:</p>		<p>Photo #:</p> <p style="text-align: center; color: red; font-weight: bold;">NA</p>	<ul style="list-style-type: none"> • Reconfigure space • •
<p>3.15 If there is a privacy wall and the door swings in, is there at least 24 inches of maneuvering clearance beyond the door latch side and at least 48 inches to the privacy wall if there is no door closer or at least 54 inches if there is a door closer?</p>	<p><input type="checkbox"/> Yes <input type="checkbox"/> No</p> <p>Measurement:</p>		<p>Photo #:</p> <p style="text-align: center; color: red; font-weight: bold;">NA</p>	<ul style="list-style-type: none"> • Reconfigure space • •
<p>In the Toilet Room</p>				
<p>3.16 Is there a clear path to at least one of each type of fixture, e.g. lavatory, hand dryer, etc., that is at least 36 inches wide?</p>	<p><input type="checkbox"/> Yes <input checked="" type="checkbox"/> No</p> <p>Measurement:</p> <p style="color: red; font-weight: bold;">33"</p>		<p>Photo #:</p>	<ul style="list-style-type: none"> • Remove obstructions • •

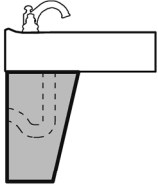
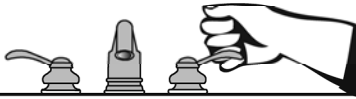
			Photo #: 3.16	
<p>3.17 Is there clear floor space available for a person in a wheelchair to turn around, i.e. a circle at least 60 inches in diameter or a T-shaped space within a 60-inch square?*</p>	<p><input checked="" type="checkbox"/> Yes <input type="checkbox"/> No</p> <p>Measurement: 126" x 52"</p>		Photo #: 3.17	<p>*The door to the toilet room may swing into the required turning space</p> <ul style="list-style-type: none"> • Move or remove partitions, fixtures or objects such as trash cans • •
<p>3.18 In a single user toilet room if the door swings in and over a clear floor space at an accessible fixture, is there a clear floor space at least 30 x 48 inches beyond the swing of the door?</p>	<p><input type="checkbox"/> Yes <input type="checkbox"/> No</p> <p>Measurement:</p>		<p>NA</p> <p>Photo #:</p>	<ul style="list-style-type: none"> • Reverse door swing • Alter toilet room •
<p>3.19 If the mirror is over a lavatory or countertop, is the bottom edge of the reflecting surface no higher than 40 inches above the floor? Or If the mirror is not over the lavatory or countertop, is the</p>	<p><input checked="" type="checkbox"/> Yes <input type="checkbox"/> No</p> <p>Measurement: 40"</p>	-		<p>* If installed before 3/15/2012 and the bottom edge of the reflecting surface is no higher than 40 inches above the floor, lowering the mirror to 35 inches is not required</p>

<p>bottom edge of the reflecting surface no higher than 35 inches above the floor?*</p>	<p><input type="checkbox"/> Yes <input type="checkbox"/> No</p> <p>Measurement: NA</p>		<p>Photo #: 3.19</p>	<ul style="list-style-type: none"> • Lower the mirror • Add another mirror •
<p>3.20 If there is a coat hook, is it no less than 15 inches and no greater than 48 inches above the floor?</p>	<p><input type="checkbox"/> Yes <input type="checkbox"/> No</p> <p>Measurement:</p>		<p>NA</p> <p>Photo #:</p>	<ul style="list-style-type: none"> • Adjust hook • Replace with or provide additional accessible hook •

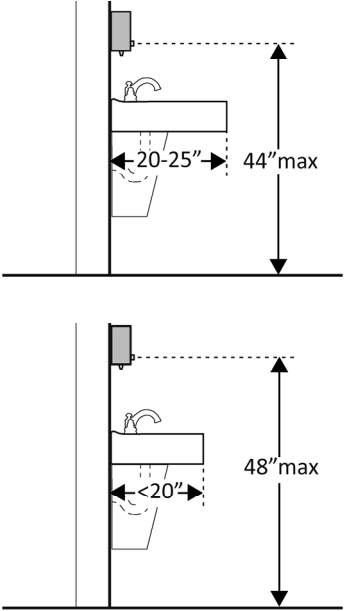
Lavatories (2010 Standards – 606) Note: 2010 Standards refer to sinks in toilet rooms as lavatories.

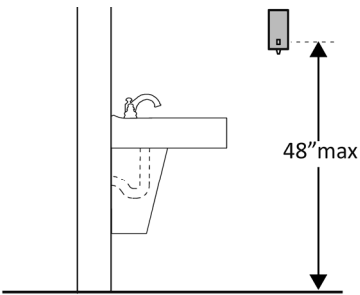
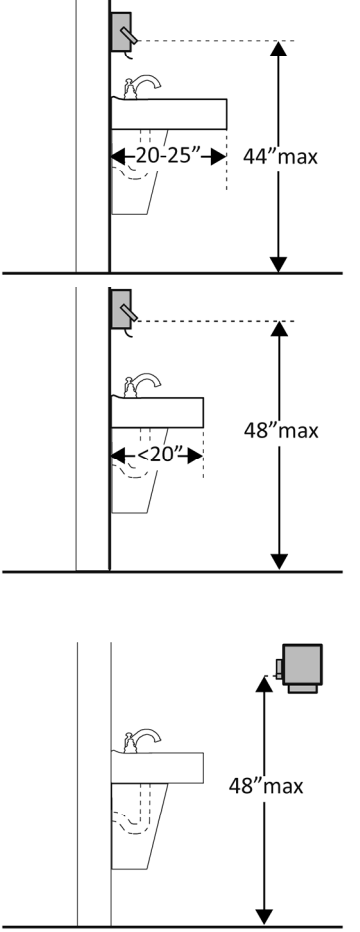
<p>3.21 Does at least one lavatory have a clear floor space for a forward approach at least 30 inches wide and 48 inches long?</p>	<p><input checked="" type="checkbox"/> Yes <input type="checkbox"/> No</p> <p>Measurement:</p>		<p>Photo #:</p>	<ul style="list-style-type: none"> • Alter lavatory • Replace lavatory •
---	--	--	-----------------	---

<p>3.22 Do no less than 17 inches and no greater than 25 inches of the clear floor space extend under the lavatory so that a person using a wheelchair can get close enough to reach the faucet?</p>	<p><input checked="" type="checkbox"/> Yes <input type="checkbox"/> No</p> <p>Measurement:</p> <p>25"</p>		<p>Photo #: 3.19</p>	<ul style="list-style-type: none"> • Alter lavatory • Replace lavatory •
<p>3.23 Is the front of the lavatory or counter surface, whichever is higher, no more than 34 inches above the floor?</p>	<p><input type="checkbox"/> Yes <input checked="" type="checkbox"/> No</p> <p>Measurement:</p> <p>36 ½"</p>		<p>Photo #: 3.23</p>	<ul style="list-style-type: none"> • Alter lavatory • Replace lavatory •
<p>3.24 Is there at least 27 inches clearance from the floor to the bottom of the lavatory that extends at least 8 inches under the lav for knee clearance?</p>	<p><input checked="" type="checkbox"/> Yes <input type="checkbox"/> No</p> <p>Measurement:</p> <p>30 ½"</p>		<p>Photo #: 3.23</p>	<ul style="list-style-type: none"> • Alter lavatory • Replace lavatory •
<p>3.25 Is there toe clearance at least 9 inches high?</p> <p>(Space extending greater than 6 inches beyond the available toe clearance at 9 inches above the floor is not considered toe clearance.)</p>	<p><input checked="" type="checkbox"/> Yes <input type="checkbox"/> No</p>		<p>Photo #: 3.17</p>	<ul style="list-style-type: none"> • Alter lavatory • Replace lavatory •

<p>3.26 Are pipes below the lavatory insulated or otherwise configured to protect against contact?</p>	<p><input type="checkbox"/> Yes <input checked="" type="checkbox"/> No</p>		<p>Photo #: 3.17</p>	<ul style="list-style-type: none"> • Install insulation • Install cover panel •
<p>3.27 Can the faucet be operated without tight grasping, pinching, or twisting of the wrist?</p> <p>Is the force required to activate the faucet no greater than 5 pounds?</p>	<p><input checked="" type="checkbox"/> Yes <input type="checkbox"/> No</p> <p><input type="checkbox"/> Yes <input type="checkbox"/> No</p> <p>NA</p>		<p>2 – lavs with sensor faucets</p> <p>Photo #3.19</p>	<ul style="list-style-type: none"> • Adjust faucet • Replace faucet •

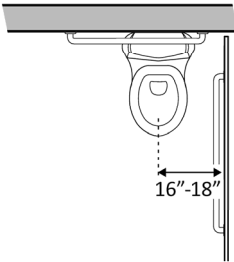
Soap Dispensers and Hand Dryers (2010 Standards – 603)

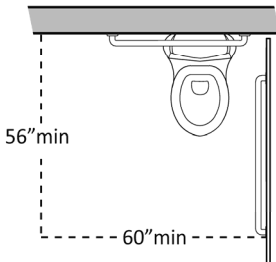
<p>3.28 Are the operable parts of the soap dispenser within one of the following reach ranges:</p> <p>Above lavatories or counters no less than 20 inches and no greater than 25 inches deep: no higher than 44 inches above the floor?</p> <p>Above lavatories less than 20 inches deep: no higher than 48 inches above the floor?</p> <p>Not over an obstruction: no higher than 48 inches above the</p>	<p><input type="checkbox"/> Yes <input checked="" type="checkbox"/> No</p> <p>Measurement: 47"</p> <p><input type="checkbox"/> Yes <input type="checkbox"/> No</p> <p>Measurement:</p> <p><input type="checkbox"/> Yes <input type="checkbox"/> No</p>			<ul style="list-style-type: none"> • Adjust dispensers • Replace with or provide additional accessible dispensers •
---	---	---	--	--

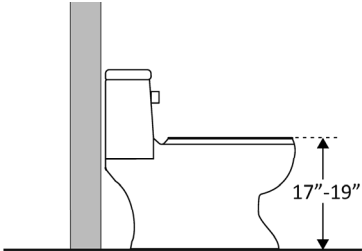
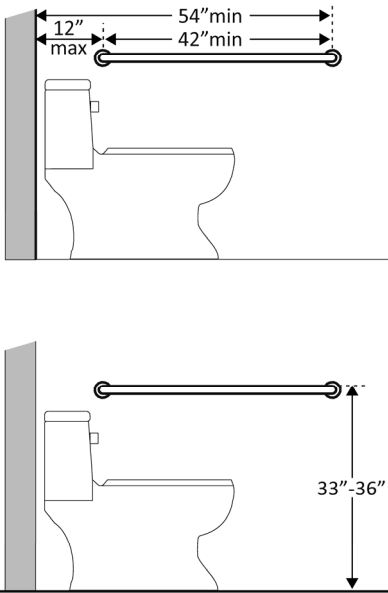
<p>floor?</p>	<p>Measurement:</p>		<p>Photo #: 3.19</p>	
<p>3.29 Are the operable parts of the hand dryer or towel dispenser within one of the following reach ranges:</p> <p>Above lavatories or counters no less than 20 inches and no greater than 25 inches deep: no higher than 44 inches above the floor?</p> <p>Above lavatories less than 20 inches deep: no higher than 48 inches above the floor?</p> <p>Not over an obstruction: no higher than 48 inches above the floor?</p> <p>Can the operable parts of the hand dryer or towel dispenser be operated without tight grasping, pinching or twisting of the wrist?</p> <p>Is the force required to activate the hand dryer or towel</p>	<p><input type="checkbox"/> Yes <input type="checkbox"/> No</p> <p>Measurement:</p> <p><input type="checkbox"/> Yes <input type="checkbox"/> No</p> <p>Measurement:</p> <p><input checked="" type="checkbox"/> Yes <input type="checkbox"/> No</p> <p>Measurement:</p> <p>42"</p> <p><input checked="" type="checkbox"/> Yes <input type="checkbox"/> No</p> <p><input checked="" type="checkbox"/> Yes <input type="checkbox"/> No</p>		<p>Photo #: 3.29</p>	<ul style="list-style-type: none"> • Adjust dispensers • Replace with or provide additional accessible dispensers •

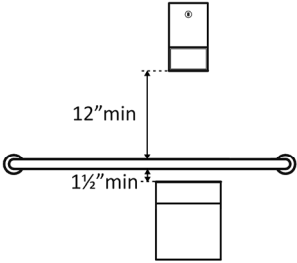
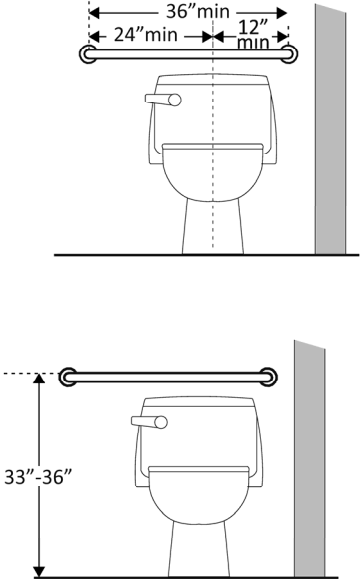
<p>dispenser no greater than 5 pounds?</p>	<p>Measurement: 3 lbs</p>			
--	--------------------------------------	--	--	--

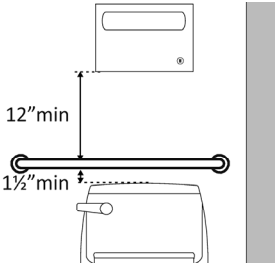
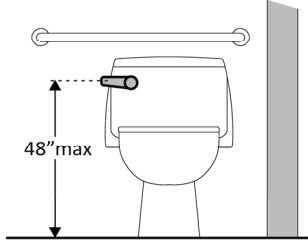
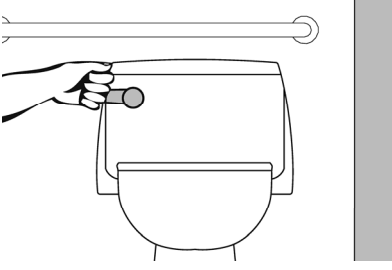
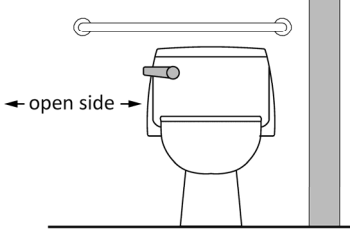
Water Closets in Single-User Toilet Rooms and Compartments (Stalls) (2010 Standards – 603 & 609) Note: 2010 Standards refer to toilets as water closets.

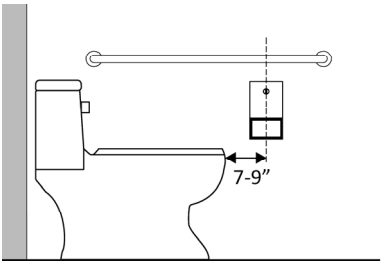
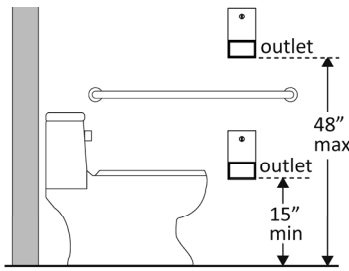
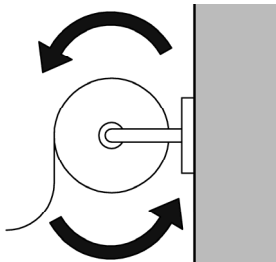
<p>3.30 Is the centerline of the water closet no less than 16 inches and no greater than 18 inches from the side wall or partition?</p>	<p><input type="checkbox"/> Yes <input checked="" type="checkbox"/> No</p> <p>Measurement: 20"</p>		<p>Photo #: 3.30</p>	<ul style="list-style-type: none"> • Move toilet • Replace toilet • Move partition •
--	---	--	-----------------------------	--

<p>3.31 Is clearance provided around the water closet measuring at least 60 inches from the side wall and at least 56 inches from the rear wall?*</p>	<p><input type="checkbox"/> Yes <input checked="" type="checkbox"/> No</p> <p>Measurement:</p>		<p>Photo #: 3.30</p>	<p>* If constructed before 3/15/12, clearances around water closets in single user toilet rooms can be 48 inches wide by 66 inches long or 48 inches wide by 56 inches long (depending on the approach to the water closet, see 1991 Standards Figure 28) and the lavatory may overlap that clearance if the door to the room does not swing into the required clearances at fixtures (such as lavatories, water closet</p>
--	--	--	-----------------------------	---

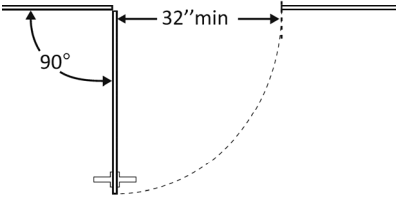
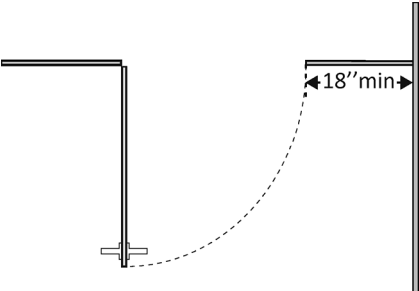
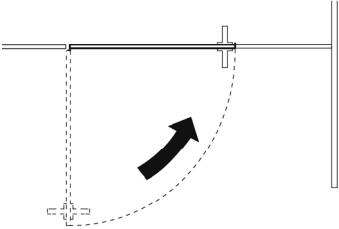
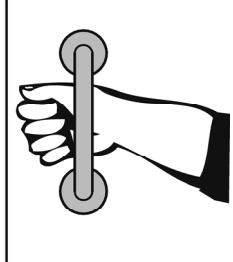
			<p>Photo #: 3.30</p>	<p>and urinals) and the edge of the lavatory is at least 18 inches from the centerline of the water closet</p> <ul style="list-style-type: none"> Alter room/compartment for clearance
<p>3.32 Is the height of the water closet no less than 17 inches and no greater than 19 inches above the floor measured to the top of the seat?</p>	<p><input checked="" type="checkbox"/> Yes <input type="checkbox"/> No</p> <p>Measurement:</p> <p>18"</p>		<p>Photo #: 3.30</p>	<ul style="list-style-type: none"> Adjust toilet height Replace toilet
<p>3.33 Is there a grab bar at least 42 inches long on the side wall?</p> <p>Is it located no more than 12 inches from the rear wall?</p> <p>Does it extend at least 54 inches from the rear wall?</p> <p>Is it mounted no less than 33 inches and no greater than 36 inches above the floor to the top of the gripping surface?</p> <p>Is there at least 12 inches clearance between the grab bar</p>	<p><input type="checkbox"/> Yes <input checked="" type="checkbox"/> No</p> <p>Measurement:</p> <p>32"</p> <p><input checked="" type="checkbox"/> Yes <input type="checkbox"/> No</p> <p>Measurement:</p> <p>ATTACHED TO WALL</p> <p><input type="checkbox"/> Yes <input type="checkbox"/> No</p> <p>Measurement:</p> <p>32"</p> <p><input type="checkbox"/> Yes <input checked="" type="checkbox"/> No</p> <p>Measurement:</p> <p>30"</p> <p><input type="checkbox"/> Yes <input type="checkbox"/> No</p>		<p>Photo #: 3.30</p>	<ul style="list-style-type: none"> Install grab bar Relocate grab bar Relocate objects <p>* If constructed before 3/15/2012 grab bars do not need to be relocated;</p>

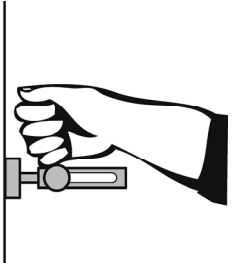
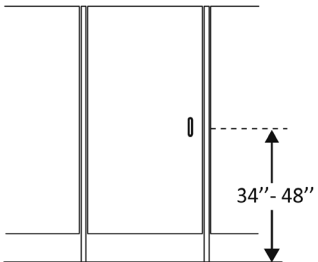
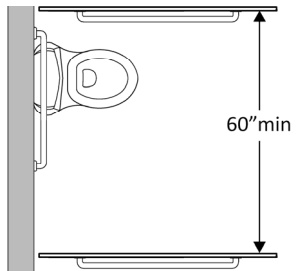
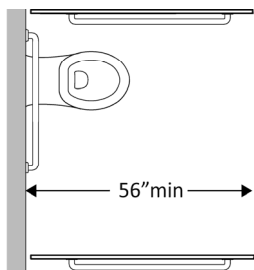
<p>and protruding objects above?*</p> <p>Is there at least 1½ inches clearance between the grab bar and projecting objects below?*</p> <p>Is the space between the wall and the grab bar 1 ½ inches?</p>	<p>Measurement: 4 ½" TO PAPER DISPENSER</p> <p><input type="checkbox"/> Yes <input type="checkbox"/> No</p> <p>Measurement:</p> <p><input type="checkbox"/> Yes <input type="checkbox"/> No</p> <p>Measurement:</p>		<p>Photo #: 3.30</p>	<p>there are no space requirements above and below grab bars in the 1991 Standards</p>
<p>3.34 Is there a grab bar at least 36 inches long on the rear wall?</p> <p>Does it extend at least 12 inches from the centerline of the water closet on one side (side wall)?</p> <p>Does it extend at least 24 inches on the other (open) side?</p> <p>Is it mounted no less than 33 inches and no greater than 36 inches above the floor to the top of the gripping surface?</p> <p>Are there at least 12 inches clearance between the grab bar and protruding objects above?*</p> <p>Are there at least 1½ inches</p>	<p><input type="checkbox"/> Yes <input checked="" type="checkbox"/> No</p> <p>Measurement: 24"</p> <p><input checked="" type="checkbox"/> Yes <input type="checkbox"/> No</p> <p>Measurement: 12"</p> <p><input type="checkbox"/> Yes <input checked="" type="checkbox"/> No</p> <p>Measurement:</p> <p><input checked="" type="checkbox"/> Yes <input type="checkbox"/> No</p> <p>Measurement: 34"</p> <p><input type="checkbox"/> Yes <input type="checkbox"/> No</p> <p>Measurement: NA</p>		<p>Photo #: 3.30</p> <p>Photo #: 3.30</p>	<ul style="list-style-type: none"> • Install grab bar • Relocate grab bar • Relocate objects • <p>* If constructed before 3/15/2012 grab bars do not need to be relocated; there are no space</p>

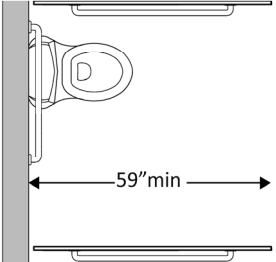
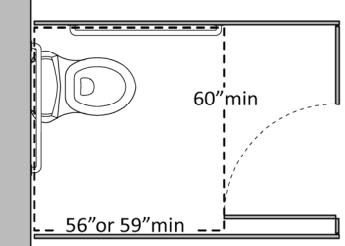
<p>clearance between the grab bar and projecting objects below?*</p> <p>Is the space between the wall and the grab bar 1 ½ inches?</p>	<p><input type="checkbox"/> Yes <input type="checkbox"/> No</p> <p>Measurement:</p> <p><input type="checkbox"/> Yes <input type="checkbox"/> No</p> <p>Measurement:</p>		<p>Photo #: 3.30</p>	<p>requirements above and below grab bars in the 1991 Standards</p>
<p>3.35 If the flush control is hand operated, is the operable part located no higher than 48 inches above the floor?</p>	<p><input type="checkbox"/> Yes <input type="checkbox"/> No</p> <p>Measurement:</p> <p>NA</p>		<p>SENSOR OPERATED</p> <p>Photo #:</p>	<ul style="list-style-type: none"> • Move control • Install sensor with override button no higher than 48 inches •
<p>3.36 If the flush control is hand operated, can it be operated with one hand and without tight grasping, pinching, or twisting of the wrist?</p> <p>Is the force required to activate the flush control no greater than 5 pounds?</p>	<p><input type="checkbox"/> Yes <input type="checkbox"/> No</p> <p><input type="checkbox"/> Yes <input type="checkbox"/> No</p> <p>Measurement:</p>		<p>NA</p> <p>Photo #:</p>	<ul style="list-style-type: none"> • Change control • Adjust control •
<p>3.37 Is the flush control on the open side of the water closet?</p>	<p><input type="checkbox"/> Yes <input type="checkbox"/> No</p>		<p>NA</p> <p>Photo #:</p>	<ul style="list-style-type: none"> • Move control • •

<p>3.38 Is the toilet paper dispenser located no less than 7 inches and no greater than 9 inches from the front of the water closet to the centerline of the dispenser?*</p>	<p><input type="checkbox"/> Yes <input checked="" type="checkbox"/> No</p> <p>Measurement:</p> <p>4"</p>		<p>Photo #: 3.30</p> <p>* If constructed before 3/15/2012 dispenser does not need to be relocated if it is within reach from the water closet seat; the 1991 Standards do not specify distance from the front of the water closet</p> <ul style="list-style-type: none"> • Relocate dispenser • •
<p>3.39 Is the outlet of the dispenser:</p> <p>Located no less than 15 inches and no greater than 48 inches above the floor?</p> <p>Not located behind grab bars?</p>	<p><input checked="" type="checkbox"/> Yes <input type="checkbox"/> No</p> <p>Measurement:</p> <p>35"</p> <p><input type="checkbox"/> Yes <input checked="" type="checkbox"/> No</p>		<p>Photo #: 3.30</p> <ul style="list-style-type: none"> • Relocate dispenser • •
<p>3.40 Does the dispenser allow continuous paper flow?</p>	<p><input checked="" type="checkbox"/> Yes <input type="checkbox"/> No</p>		<p>Photo #: 3.38</p> <ul style="list-style-type: none"> • Adjust dispenser • Replace dispenser •

Toilet Compartments (Stalls) (2010 Standards – 604)

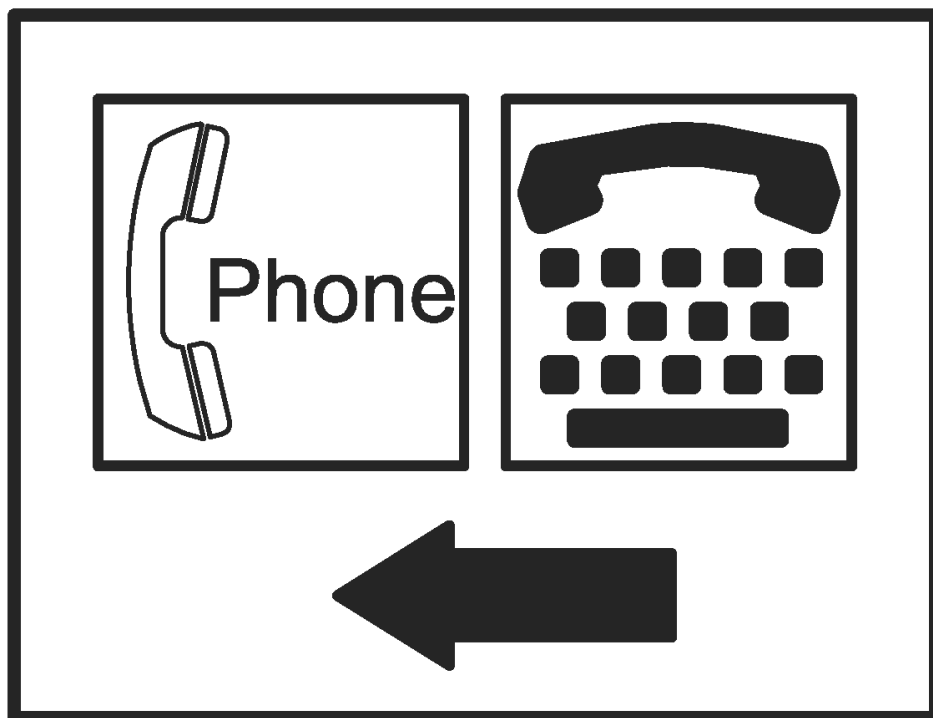
<p>3.41 Is the door opening width at least 32 inches clear, between the face of the door and the stop, when the door is open 90 degrees?</p>	<p><input checked="" type="checkbox"/> Yes <input type="checkbox"/> No</p> <p>Measurement: 32"</p>		<p>Photo #: 3.41</p>	<ul style="list-style-type: none"> • Widen door width • •
<p>3.42 If there is a front approach to the pull side of the door, is there at least 18 inches of maneuvering clearance beyond the latch side plus 60 inches clear depth?*</p>	<p><input type="checkbox"/> Yes <input checked="" type="checkbox"/> No</p> <p>Measurement: 6" X 42"</p>		<p>Photo #: 3.42</p>	<p>*See 2010 Standards 604.8.1.2 Doors for maneuvering clearance requirements on the push side of the door and side approaches to the pull side of the door</p> <ul style="list-style-type: none"> • Remove obstructions •
<p>3.43 Is the door self-closing?</p>	<p><input type="checkbox"/> Yes <input checked="" type="checkbox"/> No</p>		<p>Photo #: 3.42</p>	<ul style="list-style-type: none"> • Add closer • Replace door •
<p>3.44 Are there door pulls on both sides of the door that are operable with one hand and do not require tight grasping pinching or twisting of the wrist?*</p>	<p><input type="checkbox"/> Yes <input checked="" type="checkbox"/> No</p>		<p>Photo #: 3.41</p>	<p>* If constructed before 3/15/2012 door pulls do not need to be added; door pulls are not required in the 1991 Standards</p> <ul style="list-style-type: none"> • Replace hardware •

				•
<p>3.45 Is the lock operable with one hand and without tight grasping, pinching or twisting of the wrist?</p>	<p><input type="checkbox"/> Yes <input type="checkbox"/> No</p>		<p>Photo #: 3.41</p>	<ul style="list-style-type: none"> • Replace lock • •
<p>3.46 Are the operable parts of the door hardware mounted no less than 34 inches and no greater than 48 inches above the floor?</p>	<p><input checked="" type="checkbox"/> Yes <input type="checkbox"/> No</p> <p>Measurement: 40"</p>		<p>Photo #: 3.41</p>	<ul style="list-style-type: none"> • Relocate hardware • •
<p>3.47 Is the compartment at least 60 inches wide?</p>	<p><input type="checkbox"/> Yes <input checked="" type="checkbox"/> No</p> <p>Measurement: 40"</p>		<p>Photo #: 3.30</p>	<ul style="list-style-type: none"> • Widen compartment • •
<p>3.48 If the water closet is wall hung, is the compartment at least 56 inches deep?</p>	<p><input checked="" type="checkbox"/> Yes <input type="checkbox"/> No</p> <p>Measurement: 67"</p>		<p>Photo #: 3.30</p>	<ul style="list-style-type: none"> • Widen compartment • •

<p>3.49 If the water closet is floor mounted, is the compartment at least 59 inches deep?</p>	<p><input type="checkbox"/> Yes <input type="checkbox"/> No</p> <p>Measurement:</p>		<p style="text-align: center; color: red; font-weight: bold;">NA</p> <p>Photo #:</p>	<ul style="list-style-type: none"> • Alter compartment • •
<p>3.50 If the door swings in, is the minimum required compartment area provided beyond the swing of the door (60 inches x 56 inches if water closet is wall hung or 59 inches if water closet is floor mounted)?</p>	<p><input type="checkbox"/> Yes <input type="checkbox"/> No</p> <p>Measurement:</p>		<p style="text-align: center; color: red; font-weight: bold;">NA</p> <p>Photo #:</p>	<ul style="list-style-type: none"> • Reverse door swing • Alter compartment •
	<p><input type="checkbox"/> Yes <input type="checkbox"/> No</p>		<p>Photo #:</p>	<ul style="list-style-type: none"> • • •
	<p><input type="checkbox"/> Yes <input type="checkbox"/> No</p>		<p>Photo #:</p>	<ul style="list-style-type: none"> • • •

ADA Checklist for Readily Achievable Barrier Removal

Priority 4 – Additional Access



Project **SDDOT Rest Area Improvements**
FHU Reference Number 13-039-01
TSP Project Number 03120855

Building **VALLEY SPRINGS**

Location **90 W., MRM 412**

Date **09-18-2013 (Inspection)**

Surveyors **Timothy Roach, AIA**
Todd Schultz, PE

Robert King, CPD

Contact Information **TSP – (605) 343-6102**

Amenities such as drinking fountains and public telephones should be accessible to people with disabilities.



Institute for Human Centered Design
www.HumanCenteredDesign.org
November 2011

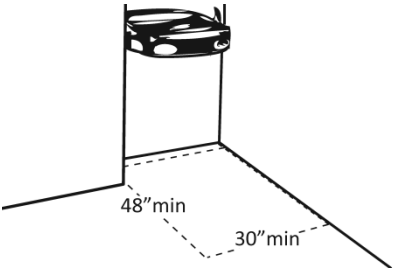
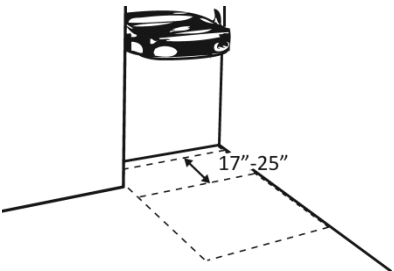
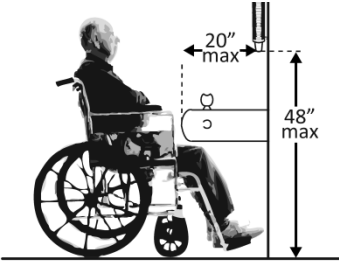


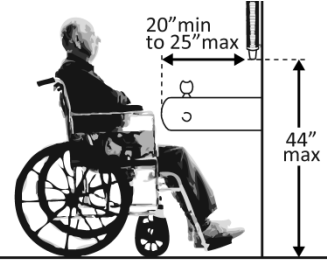

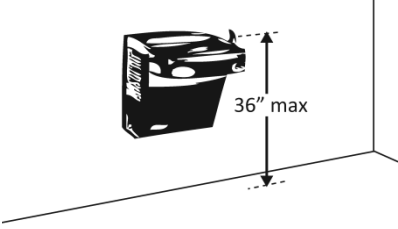
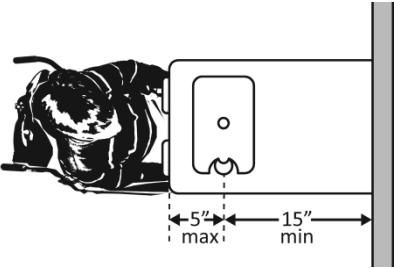
ADA National Network
Questions on the ADA 800-949-4232 voice/tty
www.ADAchecklist.org

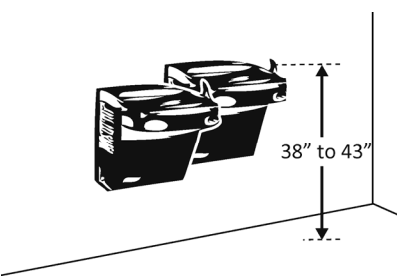
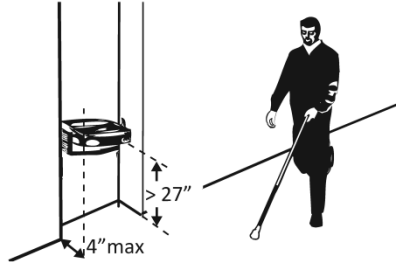
This checklist was produced by the New England ADA Center, a project of the Institute for Human Centered Design and a member of the ADA National Network. This checklist was developed under a grant from the Department of Education, NIDRR grant number H133A060092-09A. However the contents do not necessarily represent the policy of the Department of Education, and you should not assume endorsement by the Federal Government.

Questions or comments on the checklist contact the New England ADA Center at 617-695-0085 voice/tty or ADAinfo@NewEnglandADA.org

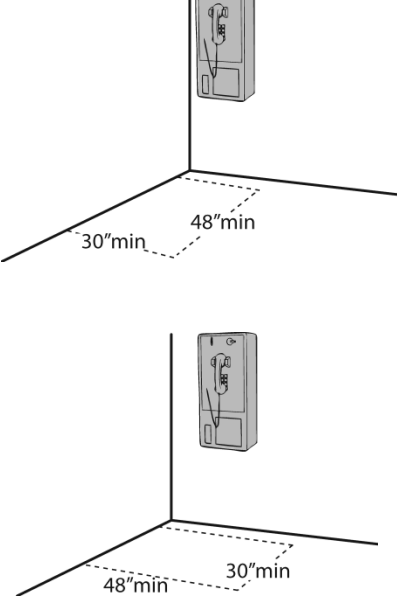
For the full set of checklists, including the checklists for recreation facilities visit www.ADAchecklist.org.

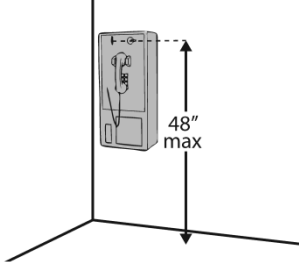
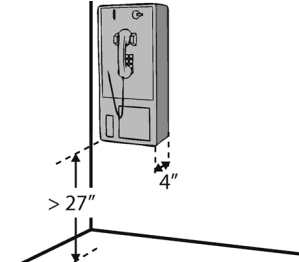


Priority 4 – Additional Access		Comments	Possible Solutions
Drinking Fountains (2010 Standards – 602)			
<p>4.1 Does at least one drinking fountain have a clear floor space at least 30 inches wide x at least 48 inches long centered in front of it for a forward approach?*</p>	<p><input checked="" type="checkbox"/> Yes <input type="checkbox"/> No</p> <p>Measurement: 46 X 48</p>		<p>Photo #: 4.1</p> <p>*If installed before 3/15/2012, a parallel approach is permitted and the clear floor space is not required to be centered</p> <ul style="list-style-type: none"> • Alter space • Relocate drinking fountain • Install a drinking fountain in another location
<p>4.2 If there is a forward approach, do no less than 17 inches and no greater than 25 inches of the clear floor space extend under the drinking fountain?</p>	<p><input type="checkbox"/> Yes <input type="checkbox"/> No</p> <p>Measurement: 25 3/4"</p>		<p>Photo #: 4.1</p> <ul style="list-style-type: none"> • Alter space • Replace drinking fountain •
<p>4.3 If the drinking fountain is no deeper than 20 inches, are the operable parts no higher than 48 inches above the floor?</p>	<p><input type="checkbox"/> Yes <input type="checkbox"/> No</p> <p>Measurement: 18 1/2" DEEP 31" ABOVE FLOOR</p>		<p>Photo #: 4.3</p> <ul style="list-style-type: none"> • Adjust drinking fountain • Replace drinking fountain •




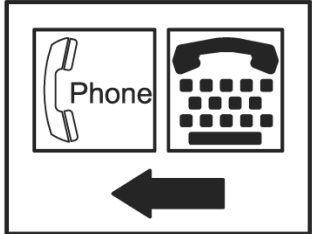
<p>4.4 If the drinking fountain is no less than 20 inches and no greater than 25 inches deep, are the operable parts no higher than 44 inches above the floor?</p>	<p><input checked="" type="checkbox"/> Yes <input type="checkbox"/> No Measurement: 28" ABOVE FLOOR</p>		<p>Photo #: 4.3</p>	<ul style="list-style-type: none"> • Adjust drinking fountain • Replace drinking fountain •
<p>4.5 Can the control be operated with one hand and without tight grasping, pinching or twisting of the wrist?</p> <p>Is the force required to activate the control no more than 5 pounds?</p>	<p><input checked="" type="checkbox"/> Yes <input type="checkbox"/> No Measurement: 1 LB</p>		<p>Photo #: 4.3</p>	<ul style="list-style-type: none"> • Change control • Adjust control •
<p>4.6 Is the spout outlet no higher than 36 inches above the floor?</p>	<p><input checked="" type="checkbox"/> Yes <input type="checkbox"/> No Measurement: 35"</p>		<p>Photo #: 4.1</p>	<ul style="list-style-type: none"> • Adjust drinking fountain • Replace drinking fountain •
<p>4.7 Is the spout:</p> <p>At least 15 inches from the rear of the drinking fountain?</p> <p>No more than 5 inches from the front of the drinking fountain?</p>	<p><input checked="" type="checkbox"/> Yes <input type="checkbox"/> No Measurement: 15 1/2"</p> <p><input checked="" type="checkbox"/> Yes <input type="checkbox"/> No Measurement: 3"</p>		<p>Photo #: 4.3</p>	<ul style="list-style-type: none"> • Adjust spout • Replace drinking fountain •




<p>4.8 If there is more than one drinking fountain, is there at least one for standing persons?</p> <p>Is the spout outlet no lower than 38 inches and no higher than 43 inches above the floor?</p>	<p><input type="checkbox"/> Yes <input type="checkbox"/> No</p> <p><input type="checkbox"/> Yes <input type="checkbox"/> No</p> <p>Measurement:</p>		<p style="text-align: center; color: red; font-weight: bold;">NA</p> <p>Photo #:</p>	<ul style="list-style-type: none"> • Adjust drinking fountain • Install new drinking fountain for standing height •
<p>4.9 If the leading (bottom) edge of the fountain is higher than 27 inches above the floor, does the front of the fountain protrude no more than 4 inches into the circulation path?</p>	<p><input type="checkbox"/> Yes <input type="checkbox"/> No</p> <p>Measurement:</p>		<p style="text-align: center; color: red; font-weight: bold;">NA</p> <p>Photo #:</p>	<ul style="list-style-type: none"> • Adjust drinking fountain • Replace drinking fountain • Add tactile warning such as permanent planter or partial walls

Public Telephones (2010 Standards – 704) TTY's are devices that employ interactive text-based communication through the transmission of coded signals across the telephone network. They are mainly used by people who are deaf and/or cannot speak.

<p>4.10 Does at least one telephone have a clear floor space at least 30 inches wide x at least 48 inches long for a parallel or forward approach?</p>	<p><input checked="" type="checkbox"/> Yes <input type="checkbox"/> No</p>		<p>Photo #: 4.1</p>	<ul style="list-style-type: none"> • Move telephone • Install new telephone for clear floor space •
---	--	---	----------------------------	--

<p>4.11 Is the highest operable part of the telephone no higher than 48 inches above the floor?</p>	<p><input type="checkbox"/> Yes <input checked="" type="checkbox"/> No</p> <p>Measurement: 68"</p>		<p>Photo #: 4.1</p>	<ul style="list-style-type: none"> • Adjust telephone • •
<p>4.12 If the leading (bottom) edge of the telephone is higher than 27 inches above the floor, does the front of the telephone protrude no more than 4 inches into the circulation path?</p>	<p><input checked="" type="checkbox"/> Yes <input type="checkbox"/> No</p> <p>Measurement: 29" ABOVE FLOOR 10" DEEP</p>		<p>Photo #: 4.1</p>	<ul style="list-style-type: none"> • Adjust telephone • •
<p>4.13 Does at least one telephone have a volume control?</p>	<p><input type="checkbox"/> Yes <input checked="" type="checkbox"/> No</p>		<p>Photo #:</p>	<ul style="list-style-type: none"> • Install volume control • Replace telephone with one that has volume control •
<p>4.14 Is the volume control identified by a pictogram of a telephone handset with radiating sound waves?</p>	<p><input type="checkbox"/> Yes <input type="checkbox"/> No</p>		<p>Photo #:</p> <p style="text-align: center;">NA</p>	<ul style="list-style-type: none"> • Add pictogram • •

<p>4.15 Does at least one telephone have a TTY?</p>	<p><input type="checkbox"/> Yes <input checked="" type="checkbox"/> No</p>		<p>Photo #:</p>	<ul style="list-style-type: none"> • Install TTY • •
<p>4.16 Is the touch surface of the TTY keypad at least 34 inches above the floor?</p>	<p><input type="checkbox"/> Yes <input type="checkbox"/> No Measurement:</p>		<p>Photo #: NA</p>	<ul style="list-style-type: none"> • If a seat is provided, TTY is not required to be 34 inches minimum above the floor • Adjust height of TTY •
<p>4.17 Is the TTY identified by the International Symbol of TTY?</p>	<p><input type="checkbox"/> Yes <input type="checkbox"/> No</p>		<p>Photo #: NA</p>	<ul style="list-style-type: none"> • Add symbol • •
<p>4.18 Do signs that provide direction to public telephones also provide direction to the TTY?</p>	<p><input type="checkbox"/> Yes <input type="checkbox"/> No</p>		<p>Photo #: NA</p>	<ul style="list-style-type: none"> • Add signs • •

<p>4.19 Do telephones that do not have a TTY provide direction to the TTY?</p>	<p><input type="checkbox"/> Yes <input type="checkbox"/> No</p>	 	<p style="text-align: center;">NA</p> <p>Photo #:</p>	<ul style="list-style-type: none"> • Add signs • •
<p>Fire Alarm Systems (2010 Standards – 702)</p>				
<p>4.20 If there are fire alarm systems, do they have both flashing lights and audible signals?</p>	<p><input type="checkbox"/> Yes <input type="checkbox"/> No</p>		<p style="text-align: center;">NA</p> <p>Photo #:</p>	<ul style="list-style-type: none"> • Install audible and visual alarms • •
	<p><input type="checkbox"/> Yes <input type="checkbox"/> No</p>		<p>Photo #:</p>	<ul style="list-style-type: none"> • • •
	<p><input type="checkbox"/> Yes <input type="checkbox"/> No</p>		<p>Photo #:</p>	<ul style="list-style-type: none"> • • •
	<p><input type="checkbox"/> Yes <input type="checkbox"/> No</p>		<p>Photo #:</p>	<ul style="list-style-type: none"> • • •

Valley Springs PRIORITY 1



Photo #1.1 10-04-2013 020



Photo #1.2 IMG-0067



Photo #1.3 IMG_0055



Photo #1.4 IMG_0062

Valley Springs PRIORITY 1



Photo #1.5 IMG_0057



Photo #1.7 10-04-2013 022



Photo # 1.8.1



Photo #1.8.2

Valley Springs PRIORITY 1



Photo # 1.9



Photo # 1.10 10-04-2013 023



Photo #1.12 10-04-2013 021



Photo # 1.13 IMG_7726

Valley Springs PRIORITY 1



Photo # 1.17



Photo # 1.19 10-04-2013 020



Photo # 1.37 10-04-2013 025



Photo # 1.41 10-04-2013 024

Valley Springs PRIORITY 1



Photo # 1.46 10-04-2013 026

Valley Springs PRIORITY 2



Photo #2.1 10-04-2013 027



Photo #2.2 IMG-7696



Photo #2.8 IMG_7622



Photo #2.38 10-04-2013 032

Valley Springs PRIORITY 2



Photo #2.47 IMG_7621

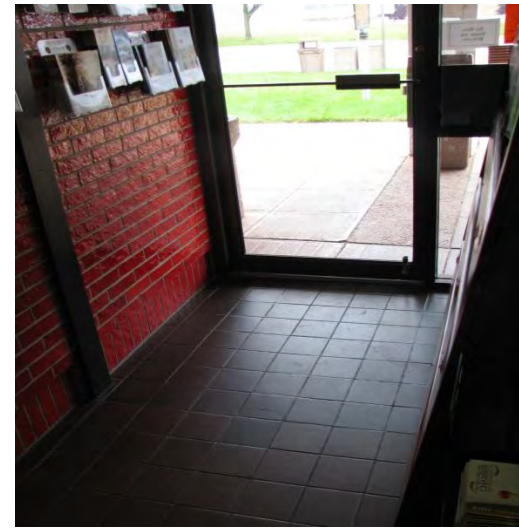


Photo #2.48 10-04-2013 031



Photo # 2.76 IMG_7619

Valley Springs PRIORITY 3 – MEN'S



Photo #3.1



Photo #3.4

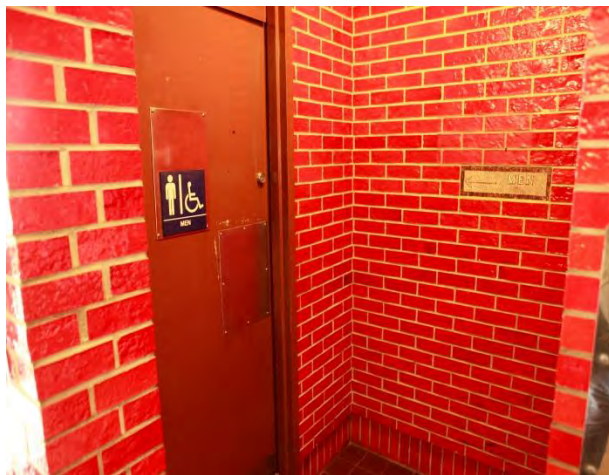


Photo #3.5



Photo #3.6

Valley Springs PRIORITY 3 – MEN'S



Photo #3.9



Photo # 3.11



Photo # 3.16



Photo #3.17

Valley Springs PRIORITY 3 – MEN'S



Photo # 3.19

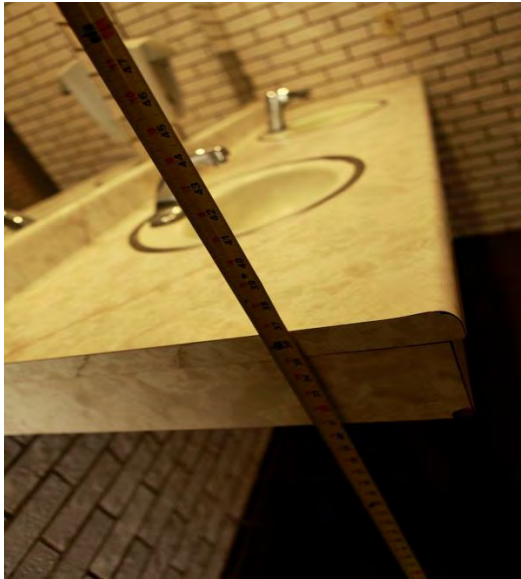


Photo # 3.23



Photo #3.25



Photo # 3.28

Valley Springs PRIORITY 3 – MEN'S



Photo # 3.29



Photo # 3.30



Photo #3.38

Valley Springs PRIORITY 3 – MEN'S



Photo # 3.43

Photo # 3.44



Valley Springs PRIORITY 3 – WOMEN'S

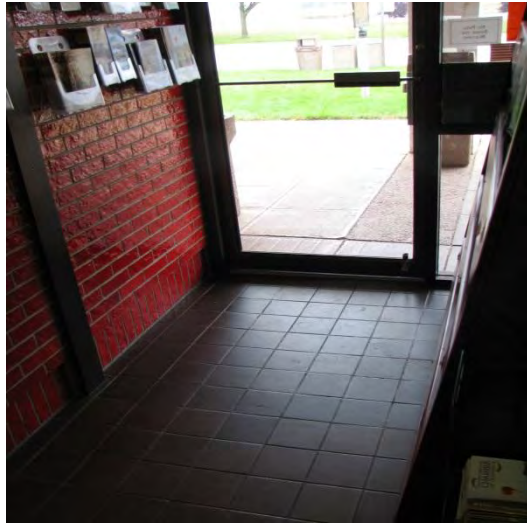


Photo #3.4



Photo #3.4



Photo #3.5



Photo #3.6

Valley Springs PRIORITY 3 – WOMEN'S



Photo #3.7



Photo # 3.9



Photo # 3.11



Photo #3.16

Valley Springs PRIORITY 3 – WOMEN'S



Photo # 3.17



Photo # 3.19



Photo #3.23



Photo # 3.28

Valley Springs PRIORITY 3 – WOMEN'S



Photo # 3.29



Photo # 3.30



Photo #3.38



Photo # 3.41

Valley Springs PRIORITY 3 – WOMEN'S



Photo # 3.42

Photo # 3.43



Valley Springs PRIORITY 4



Photo #4.1



Photo #4.6



Photo # 4.10



The Interstate Rest Areas Study: Along the I-29 and I-90 Corridors

APPENDIX C AUDITMATE SUMMARY

Detailed Component List for One Facility
MINN_RA Valley Springs Rest Area

10/17/2013

Class	Component	Comment	Quantity	Unit Cost	Lifespan	Age	Installed	Renewal Cost (RC)	Deferred Cost (DC)
Site Structures									
	Storage Building/Garage (approx. 20' x 24')		1	10,000	15			10,000	
	Lodge Pole/ Teepee Structure	Fair condition, routine structural review recommended	1				1966	30000	
	Picnic Shelters -(Glazed brick & Block, flat mtl deck & trim)	Repair & refinish Steel Roof deck & mtl trim, provide masonry cleaning, and misc. minor repairs	4						
	Reinforced Concrete Picnic Tables/Benches	Good condition	6						
	Information Display (outdoor)	Good condition - needs cleaning	1						
	Concrete Benches (backless)	Good condition	2						
Exterior Closure									
	Masonry Wall Mortar, Concrete Mortar	Good Condition, minor cleaning and repairs recommended	1200 SF/Wall	\$12.75	40	40	1973	\$15,300	\$0
	Reinforced Concrete Columns, and 2-way concrete deck	Minor spalling only. Good condition							
	Paint or Stain, Exterior	Good Shape							
	Storefront Single Door, Metal and Glass								
	Aluminum Frame and Glazing	Should be replaced with Insul. Glass System							
Roofing and Drainage									
	Asphalt Shingle Roof (GARAGE?)								
	Box Steel Panel Roof (??)								
	Foam Roof (Verify, TSP Learned that replacement roof was white membrane)								
Interior Construction									
	Toilet Partition, Stainless Steel	worn							
	Ceramic- Quarry Tile Floor 6"x6"	Fair Condition overall - most worn in lobby							
	Toilet Stall Door, Stainless Steel	worn							
	Glazed Brick Walls	Good Condition overall							
	Interior Doors & Hardware								
	Information Gate Assembly	Looks worn and old.							
	Information Desk/Counter	Looks worn and old.							
	Interior Paint/ceiling								
Plumbing									
	Tank, Holding Tank, 6,000 gallons	There are reported issues. Suggest periodically testing for bacterial growth in the tanks. Tanks is beyond it's expected service life.	1		30	40	1973		
	Well Pressure Tank, Medium	Tanks appear to be in good condition. No visible leaks.	4		30	40	1973		
	Water Cooler, Stainless Steel	Fully operational with only preventive maintenance or minor repairs required.	1		40	7	2006		

**Detailed Component List for One Facility
MINN_RA Valley Springs Rest Area**

10/17/2013

Class	Component	Comment	Quantity	Unit Cost	Lifespan	Age	Installed	Renewal Cost (RC)	Deferred Cost (DC)
	Well Pump	The well pump is operational, but appears to be original equipment.	1 each		40	40	1973		
	Water Heater, Residential, Electric, 20-50 Gallons	Fully operational. However, beyond it's expected service life.	1 each		12	19	1994		
	Water Heater, Residential, Electric, 20-50 Gallons	Fully operational with only preventive maintenance or minor repairs required.	1 each		12	5	2008		
	Faucet (Lavatory)	Faucets are sensor type, battery powered. Maintenance person said that the faucets need unscheduled maintenance more than three times per year.	4		20	13	2000		
	Lavatory Sink, Set in Countertop	Fixtures are showing wear and deterioration due to age.	4 each	\$320.00	40	40	1973	1,280	0
	Urinals Flush Valves	Flush valves are sensor type, battery powered. Maintenance person said that the valves need unscheduled maintenance more than three times per year.	3 each		20	13	2000		
	Urinals, Porcelain, Stall Type, Wall-Hung	Fully operational. Replacing units with low water consumption fixtures and flush valves will extend the life of the lagoon	3 each	\$1,200.00	40	40	1973	3,600	0
	Water Closet Flush Valves	Flush valves are sensor type, battery powered. Maintenance person said that the valves need unscheduled maintenance more than three times per year.	8 each		20	13	2000		
	Water Closet, Porcelain, Wall-Hung	Fully operational. Replacing units with low water consumption fixtures and flush valves will extend the life of the lagoon.	8 each	\$720.00	40	40	1973	\$5,760	\$0
	Wall Hydrant (Outside the building)	Faucet appears to be operable, but is beyond its expected service life.	2 each		20	40	1973		
	Hose Bibb (located in toilet rooms)	Faucet is in poor condition and may not be operable. Recommend replacement of hose bibb faucet.	2 each		20	40	1973		
	Waste and Vent Piping	Appears to be in good condition, no apparent leaks.			50	40	1973		
	Water Piping	Appears to be in good condition.			50	40	1973		
	Piping Insulation	Piping insulation is a combination of fabric jacked insulation and closed cell foam insulation. Insulation appears to be intact and will only need minor repair if damaged or modified.			30	40	1973		
	Piping Insulation	Piping insulation is a combination of fabric jacked insulation and closed cell foam insulation. Insulation appears to be intact and will only need minor repair if damaged or modified.			30	13	2000		
	Valves	Valves are starting to exhibit some corrosion. Valves may need repair or replacement soon.			50	40	1973		
	Pipe Hangers and Supports	Appears to be in good condition.			50	40	1973		

Detailed Component List for One Facility
MINN_RA Valley Springs Rest Area

10/17/2013

Class	Component	Comment	Quantity	Unit Cost	Lifespan	Age	Installed	Renewal Cost (RC)	Deferred Cost (DC)
Mechanical									
	Ceiling Fan, Paddle Blade	Operational. Fans are beyond their expected service life.	2 each	\$426.51	20	23	1990	\$853	\$853
	In-Line Exhaust fan	Utility set exhaust fans are not operational. Replacement of exhaust fans are needed.	2 each	\$1,340.00	25	40	1973	\$2,680	\$0
	Unit Heater, Electric, Ceiling or Wall Mounted (Equipment Room)	Unit is in operable condition. However, it is beyond its expected service life.	1 each	\$840.10	25	40	1973	\$840	\$0
	Unit Heater, Electric, Ceiling or Wall Mounted (Storage Room)	Fully operational. Only preventive maintenance is required.	1 each	\$840.10	25	13	2000	\$840	\$0
	Hydronic Circulating Pump, Base -Mounted, 005 HP		1 each	\$2,440.00	20	40	1973	\$2,440	\$2,440
	Window A/C Unit (Lobby)	Unit is in operable condition. However, they are inadequate for the application and does not provide adequate ventilation.	1 each	\$580.00	15	16	1997	\$580	\$0
	Window A/C Unit (Two Toilet Rooms)	Unit is in operable condition. However, they are inadequate for the application and does not provide adequate ventilation.	2 each	\$580.00	15	8	2005	\$1,160	\$0
	Radiant Heater (Flat Panel)	Units are in operable condition. However, performance is not adequate and they are showing signs of deterioration and are beyond their expected service life.	30 each	\$220.00	20	23	1990	\$6,600	\$0
	Temperature Controls	Thermostats for electric radiant panels are in working condition. However they are beyond their expected service life.	3 each		20	23	1990		
Electrical									
	Panelboard, Main Breaker, 3 PH, 208V, 0200-0400 225A	Fully operational, only preventive maintenance required.	1		50	40	1973		
	Panelboard, MLO, 3 PH, 208V, 0200-0400 225A	Fully operational, only preventive maintenance required.	1		50	40	1973		
	Fluorescent Fixture, 1' x 4', T-8 T-12	Fully operational, lamps are hard to get and expensive.	10		40	40	1973		
	Fluorescent Fixture, 1' x 4', Economy	Fully operational, lamps are hard to get and expensive.	14		40	40	1973		
	Incandescent Fixture, Surface Mounted, Stock	Fully operational, only preventive maintenance required.	4		50	7	2006		
	Incandescent Fixture, Surface Mounted, Stock	Fully operational, consider upgrading lamps to more efficient type.	4		50	40	1973		
	Outdoor fixture, Cobrahead	Fully operational, only preventive maintenance required.	10		40	17	1996		
	Outdoor Fixture, Post Top Luminaire	Internal wiring in the fixture is deteriorated	14		50	40	1973		
	Outdoor Fixture, Surface-Mounted, HID, Stock	Fully operational, some lenses show deterioration.	4		40	40	1973		
	Outdoor Fixture, Surface-Mounted, HID, Stock, Small	Fully operational, some lenses show deterioration.	8		40	40	1973		

**Detailed Component List for One Facility
MINN_RA Valley Springs Rest Area**

10/17/2013

Class	Component	Comment	Quantity	Unit Cost	Lifespan	Age	Installed	Renewal Cost (RC)	Deferred Cost (DC)
	Outdoor Fixture, Surface-Mounted, Incandescent	Fully operational, only preventive maintenance required.	1		50	7	2006		
	Outdoor Fixture, Surface-Mounted, Incandescent	Internal wiring in the fixture is deteriorated	18		50	40	1973		
	CCTV Camera w/Cabling	Fully operational, only preventive maintenance required.	7		20	13	2000		
	Electric Hand Dryer	Fully operational, only preventive maintenance required.	4		40	40	1973		
	Emergency Beacon Well Monitoring System	Understand in good condition.	1		40	40	1973		
	Phone Unit	Floor Mount, replace - Non ADA compliant	1		20	13	2000		

Utilities

Sanitary Sewer System

Lagoons	Both lagoons are scheduled to be re-lined and ripped in the near future. Both are leaking at this time according to maintenance personnel. Maintenance personnel were not sure if the ponds had adequate capacity for peak periods as they have been leaking. They will have a better idea once they are repaired.
Sewage Piping System	No problems have been reported concerning the sewer pipes and manholes.

Water System (Rural Water)

Water Pipe System	System is rural water with meter and UG storage tanks. No problems reported concerning the water system.
-------------------	--

Infrastructure

Parking Area, Non Reinforced Concrete 9.5"	Most of the concrete pavement is in good shape. There is a crack in the middle of the parking spaces that runs the length of the parking lot. This crack and other cracks and joints will need periodic repair and sealing.	154,256S.F.	\$8.50	50	40	1973	\$1,311,176	\$0
Parking Area, Asphalt	Asphalt shoulders have some alligator cracking throughout. Should probably be replaced.							
Sidewalk, Concrete	Concrete walks are generally in good shape. Approximately 10% should be replaced in the next 5-10 years. Most cracking is around the building at the Teepee Sculpture							

Detailed Component List for One Facility
MINN_RA Valley Springs Rest Area

10/17/2013

Class	Component	Comment	Quantity	Unit Cost	Lifespan	Age	Installed	Renewal Cost (RC)	Deferred Cost (DC)
	Sidewalk, Concrete	Concrete walks are generally in good shape. Approximately 10% should be replaced in the next 5-10 years. Most cracking is around the building at the Teepee Sculpture							
	Landscaping	Landscaping consists of grass and mature trees. Many trees were damaged during last year's ice storm. Refreshing of landscaping should be considered at some point. A well supplies the water for the irrigation system. The irrigation system leaks and needs some repair to address the leaks.							
	Wayfinding Signage	Signage is in good shape, but could use modernization.							
	Site Lighting - Parking	Approximately 50% of the lights don't work due to wiring per the maintenance personnel. This needs to be repaired.							

**VALLEY SPRINGS
POINT OF ENTRY
TECHNICAL REVIEW REPORT**

Prepared for:

Mr. Brad Remmich
South Dakota Department of Transportation
Office of Project Development
700 East Broadway Avenue
Pierre, SD 57501-2586
(605) 773-3093

Prepared by:

TSP
600 Kansas City Street
Rapid City, SD 57701-2712
(605) 343-6102

Felsburg Holt & Ullevig
6300 South Syracuse Way, Suite 600
Centennial, CO 80111
(303) 721-1440

FHU Reference No. 113039-01
December 2013



The Interstate Rest Areas Study: Along the I-29 and I-90 Corridors

TABLE OF CONTENTS

	<u>Page</u>
I. INTRODUCTION -----	1
II. GENERAL OVERVIEW -----	2
A. POE Site Area Layout-----	2
B. Field Visit Observations-----	4
C. User Environment -----	5
D. Existing Building Code Conformity-----	5
E. Americans with Disabilities Act (ADA) Survey -----	5
F. Energy and Water Usage Review-----	6
III. BUILDING SYSTEM OVERVIEW -----	7
A. Architectural System-----	7
B. Plumbing System-----	7
C. Mechanical System -----	7
D. Electrical System -----	8
E. Sanitary Sewer System -----	8
F. Water System -----	8
G. Infrastructure -----	9
IV. SUMMARY -----	10

APPENDIX A MAINTENANCE STAFF MEETING MINUTES

APPENDIX B ADA SURVEY RESULTS

APPENDIX C AUDITMATE SUMMARY

LIST OF FIGURES

	<u>Page</u>
Figure 1. Valley Springs Point of Entry Site Layout -----	3



I. INTRODUCTION

The Valley Springs Port of Entry (POE) facility is located along Interstate 90, near the town of Valley Springs, South Dakota. More specifically, the facility is approximately 12 miles east of the Sioux Falls metropolitan area, and adjacent to the Minnesota border line. The POE services westbound truck traffic entering into South Dakota from Minnesota.

The Port of Entry has direct access to and from Interstate 90. The access is shared with the Valley Springs Rest area facilities, which are located to the north of the POE on essentially the same property. The Valley Springs Visitor Center facilities, also located north of the POE, are reviewed in a separate report.

The POE includes the main structure, truck scales, inspections areas, and parking for trucks and employees. The building structure jointly supports the staff operating the scales, and the South Dakota Highway Patrol overseeing the inspections and patrol efforts for the area. The building has no amenities for stopped truck drivers including overnight rest periods. Trucks and their drivers must utilize the facilities at the rest area to the north.

The purpose of this report is to summarize the condition of existing site components and building systems for the facility as a whole. The intent for this report is to define the general status of the existing facilities given their age and use.

The report has been divided into two general areas of focus. The first section includes a general overview of the facility design and operations. Architectural issues, including the general capacity of the facilities and current operations, are reviewed and compared to current facility standards (i.e., building codes, ADA, etc.).

The systems overview section covers the type and condition of the components that make up the facility, and includes a summary evaluation of the site and building infrastructure. The site infrastructure repairs/replacement review includes sidewalks, lighting, signage, landscaping, and picnic shelters. The building systems infrastructure review includes items such as the building shell and structure, mechanical and plumbing systems, electrical, interior finishes, and communications/IT equipment.



II. GENERAL OVERVIEW

A. POE Site Area Layout

The developed portion of the site is bordered by the Visitor Center access road and properties to the north, and to the south by the interstate. The facility is located to the west of the property adjacent to the truck parking area. Sewage ponds supporting the facility are located on the visitor center property roughly 500' to the north east.

Outdoor facilities include:

- Truck scale unit
- Portable storage unit–steel, 12'x12'
- Truck and employee parking / inspection area
- Radio tower

Utilities Include:

- Rural water system with underground storage tank and pump to pressurize the system
- Lawn sprinkler system is supplied from visitor center system (well water)
- Gravity sewer system to lagoons (2) located on visitor center property
- Electric power and transformer
- Telephone service

The 900 square foot facility includes the following:

- Unsecured small stand up lobby
- General observation/scale room
- Office (two work stations) & storage closet
- Unisex restroom
- Shared mechanical, maintenance/lunch room

Building Systems include:

- Heating and cooling including split system air-to-air heat pump
- Exhaust only ventilation, no outside air
- Power is single phase, 120/240 volt, 225 amp

Figure 1 shows the layout of the Valley Springs Point of Entry facility including the rest area's location in relation to major roadways in the area.



Figure 1. Valley Springs Port of Entry Site Layout



B. Field Visit Observations

A field meeting was held with TSP and SDDOT officials on September 18, 2013 to gain initial insights from the SDDOT maintenance team about the operation, history, and condition of the existing on-site facilities at the Valley Springs POE. A copy of the meeting minutes are contained in **Appendix A** of this report and the following summarizes the key points of the meeting:

- Operationally, the main issue is the confusion created by the shared ramps with the Visitor Center. The shared entrance ramp is unusual and unexpected by drivers. This is a main cause for problems and complaints, as truck drivers either bypass the POE unintentionally or mistakenly enter the visitor center entrance. Drivers then require a police escort to travel back to the POE.
- The facility was constructed in 1984 with no major building expansions since construction. Enhancements to the facility have occurred including the metal storage shed, the conversion of the mechanical room to a lunch/break room, and IT electrical upgrades to support the additional workstations in the office and scales room.
- ADA upgrades for this facility are needed and feasible, with the exception of providing for truck driver facilities on site.
- The facility was designed to be minimally occupied. The building structure appears noticeably undersized for its current use, and was designed for staff associated with management of the scales. The current facility is not large enough to support the needs for the State Highway Patrol inspection and patrol functions.
- At the time of our site visit, there were eight people present (moving in and out) plus two truck drivers in the lobby. There was insufficient space to support this activity. In addition, there is no support space for meetings and storage equipment to support general operations.
- Given the age, condition, and limitations of the existing site and facilities, substantial reinvestment in this site may be required. Prior to any investment, studies should be provided to review the option of relocation of some of the patrol functions, expanding the existing facilities, or enhancing how the site is accessed.
- The scale system sometimes freezes in the winter, causing the station to be shut-down. A maintenance person must climb into the scale pit and apply temporary heat to the scale system to make it operational.
- For a multitude of reasons, the Highway Patrol would like to see facility inspection function placed indoors as is in other facilities and for their operations as a whole to be physically separated from the visitor center.



C. User Environment

The facility was originally designed with little amenities, is currently in poor condition and in need of interior and exterior refurbishment. Architecturally, the facilities are not inviting or are the interiors pleasant visually.

The information space is cluttered and dark, there is lack of good ventilation and lighting, and the overall site is nearing its design life. The site is mostly concrete with general lighting and little landscaping.

D. Existing Building Code Conformity

The current facilities were designed and constructed in 1984 to the codes at the time, which lacked consideration for people with disabilities. To quantify the differences in code standards, the existing main building was evaluated per the ICC 2012 International Building Code which has been adopted by the State of South Dakota. Based on the use of the existing facility, the following building classifications were utilized in the comparison:

- Size: 900 square feet
- Occupant Type/use group: Office
- Construction Type: Type 5-b
- Occupant Load: < 15
- Maximum access travel: 75 feet
- Required Exits: 1 (2 provided)

The following outline the major areas where the existing building deviates from the requirements of the current Building Code (IBC 2012):

- The information desk requires additional power outlets.
- Recommend a review of electrical power to address the added workstations.
- The HVAC system does not have an outside air connection for ventilation air.
- The ceiling exhaust fan systems are inadequate or inoperable.
- Several non-major items should be addressed for ADA compliant per ICC A117.1-2009 (outlined in following sections).

It should be noted that per the “Existing” Building Code, unless there are significant safety hazards, the facilities are not required to be modernized as a whole to meet current code standards. However, any repairs or new additions will need to be completed to these standards. The exception concerns ADA requirements, which are a retroactive federal requirement. When the ADA is addressed the project will need to also be completed per building code, which includes accessibility criteria (ICC- A117.1-2009).

E. Americans with Disabilities Act (ADA) Survey

As stated previously, the building was originally constructed prior to the full implementation of ADA standards. To quantify the improvements required for compliance with current ADA standards, a detailed survey was completed utilizing the “ADA Checklist for Readily Achievable Barrier Removal” per the DOJ ADA Standards for Accessible Design - 2010. The survey



identified the following general deficiencies, and more detailed information is referenced in **Appendix B** of this report:

Priority 1 Deficiencies (access to building):

- No accessible parking spaces, signs or pavement markings are provided at this time
- Any accessible spaces would need to be either at the back of the building near the east or west walks or along the east side of the building near the back of the building
- Accessible routes are available along the east and west sides of the building. The ramp along the east side of the building would need some upgrades to meet current ADA standards
- ADA pull handle on entrance door has insufficient clearance
- Door closer takes less than 5 seconds to close from an open position

Priority 2 Deficiencies (Access to Goods and Services):

- Doorways from the lobby to the restroom does not have sufficient corridor width. There is insufficient ADA clearance with the existing 36" wide opening when using operable restroom entrance doors (46-52" min. required depending upon configuration)
- Information Area:
 - Area behind counter - height does not meet ADA clearance or height standards.
 - There is a section of counter that is higher than 36 inches above the floor
 - Signage, provide signs to current ADA standards

Priority 3 (Restroom):

- There is no signage to meet ADA standards
- The door hardware is not located in compliance with ADA standards
- The type of door hardware used is not in compliance with ADA standards
- The door does not have a closer
- Pipes below the lavatory is not insulated or covered
- There is no permanently mounted soap dispenser
- Toilet is more than 18 inches from the side wall or partition
- Grab bars do not meet ADA standards
- Toilet paper holder does not meet ADA standards
- Toilet room is not ADA accessible because door opening is less than 32" wide

Priority 4 (additional access) Deficiencies:

- There is no public access telephone.
- There is no public access drinking fountain.

F. Energy and Water Usage Review

TSP has not received any data to review and comment on.



III. BUILDING SYSTEM OVERVIEW

The following sections include a general review of individual building and site components, starting with site components and then broken down by individual disciplines (Architectural Systems, Mechanical, Electrical, Plumbing, and Civil/Site systems). The discussion generally parallels SDDOT AuditMate database format.

A detailed summary of each discipline section in the current AuditMate format including general comments of individual line items are contained in **Appendix C** included in this report. The table contains both existing line items and recommended updates to the SDDOT database, which are shown in **bold** font.

A. *Architectural System*

The original structure was constructed in 1984 as a four season structure. There have been limited upgrades to support the added personnel inside including the office, the scale team work area, the conversion of the mechanical room to a break room, and the addition of a temporary storage unit outside.

The building structure consists of wood frame construction on concrete foundations and slab. The exterior is brick veneer, with painted textured siding above the eave lines. The roof include wood trusses and asphalt shingle and aluminum gutter system. Interiors include insulated suspended gypsum board ceiling with surface mounted lighting. Walls are painted gypsum board, floors are vinyl tile.

B. *Plumbing System*

Toilet room fixtures, floor mounted water closet and wall hung lavatory sink are vitreous china. The lavatory faucet is manual type and does not meet ADA requirements. The water closet is a tank type, and the service sink in the equipment / break room is wall-hung, enameled cast iron. Plumbing fixtures are original installed in 1984. The electric water cooler has been replaced in 2006 with a filtered water dispenser inside the building.

Waste and vent piping is cast iron and original (1984). Water piping is copper and original equipment, while the piping insulation is original fabric covered pipe type.

Water for domestic use is supplied by a rural water system at the Visitor Center Building which is routed to the Port of Entry building. The system has a water pressure regulator, water meter, and backflow preventer located in the Visitor Center Building. Water for the lawn irrigation system is supplied from a well and a pressure booster pump system that is located in the Visitor Center building. The domestic water is heated with an electric water heater, installed in 1994, located in the equipment / break room.

C. *Mechanical System*

The building is heated and cooled by a split-system air-to-air heat pump system. The supply air is distributed by ducts located under insulation in the attic space, and there is one return air grille, located in the lobby. The system does not keep the building occupants comfortable,



specifically near the windows in the scale room. The system does not provide any outside air for ventilation.

Exhaust ventilation for the toilet room is provided by a small ceiling mounted fan/light that is ducted to the outside of the building. Exhaust ventilation for the equipment / break room is provided by a small ceiling mounted fan/light that is ducted to the outside of the building. This fan was not operable at the time of the inspection. The exhaust systems are original (1984).

D. Electrical System

The building is served by a one phase 240 volt,, 225 amp service. There is one 225 amp panel located the equipment / break room, and the panel is clearly labeled as to what each breaker serves. All wiring is run in conduit, and the panel appears to be original equipment from 1984.

All indoor lighting fixtures are original (1984). All lamps are mainly fluorescent with some incandescent lamps. The lighting fixtures in the building are a mix of surface mounted fluorescent in all rooms except the storage closet, equipment / break room and toilet room which have incandescent fixtures.

Outdoor lighting is primarily high pressure sodium or HID. Surface mounted fixtures are used on the building. Lights on the front of the building for the scale area are incandescent flood lights. Most outdoor lighting is original, installed in 1984.

There is telephone and internet service to the building. Also, there is a large radio antenna system for communication with highway patrol vehicles.

E. Sanitary Sewer System

The sanitary sewer system consists of gravity flow sewer lines to two sewage lagoons located to the north and east end of the site of the POE. Each of the two ponds approximately the same size, with the south pond providing overflow protection for the north pond. Maintenance personal suspect both ponds are leaking and would benefit from re-lining and riprap work in the near future. The adequacy of the capacity of the ponds is not known due to their leaking. The piping to the ponds is adequate and has not caused any problems.

F. Water System

Water is supplied by rural water. No problems were reported. There is a well in the rear of the Rest Area building to the north of the POE that is used for irrigation.



G. Infrastructure

The main parking area and traveled way are concrete pavement. Most of the pavement appears in good shape. (No SDDOT pavement ratings were available for this site.) Approximately 10-15% of the panels will need replacement in the next 5-10 years due mostly to corner cracking. Joint maintenance, repair and sealing may also need to be done.

There is asphalt paving on the east end of the parking area. Approximately 2/3 of this area is in poor condition and will need to be removed and replaced in the next 5 years. The remainder of the area could be chip or slurry sealed to keep it in service for the next 10 years.

Concrete walk consists of walks on the east, west and south sides of the building. Walk on the east side of the building is in good shape. The walks on the west and south side are elevated with a ramp up to them from the north. The railing on the elevated area is in poor condition and needs to be replaced. If this walk is going to be used for accessible access, the ramp will need to be updated to meet ADA requirements.



IV. SUMMARY

The Valley Springs POE is located along Interstate 90 supporting westbound traffic. More specifically, the site is adjacent to the Minnesota border approximately 12 miles east of the Sioux Falls, South Dakota metropolitan area.

The POE has direct access to and from Interstate 90; this same access is shared with the Rest Area Facilities located north of the POE on essentially the same property. Truck drivers must park at the POE and walk to the visitor center to utilize the facilities.

The purpose of this report was to summarize the condition of existing site components and building systems for the facility as a whole, and to define the general status of the existing facilities given their age and use.

Prior to reinvesting in a building refurbishment, it is important to define the long-range plans for this site. The site is limited in area which may hamper future growth options which may possibly include the expansion of the POE building, a new enclosed inspection area, expansion of truck parking, reworking of truck maneuvering, and possible retention pond development (LEED). And most importantly, addressing trucker confusion in accessing the properties is also a priority.

The facility will need to be modified to comply with ADA/building code requirements. The extent of which has yet to be determined, as an additional factor will be in identifying the added space required to modify the restroom entrances, to support increased user loads (if any), and to provide family assist restroom(s).



The Interstate Rest Areas Study: Along the I-29 and I-90 Corridors

APPENDIX A MAINTENANCE STAFF MEETING MINUTES



October 15, 2013

MEETING MINUTES

SDDOT INTERSTATE REST AREA STUDY

FHU Reference No. 113039-01

Valley Springs POE Maintenance Review Meeting

Valley Springs POE Rest Area

Date of Meeting: September 18, 2013

In attendance:

- Brad Remmich – SDDOT
- Jeff Gustafson – SDDOT
- Keith Voegeli – SDDOT
- Sergeant Matt Cole – SD Highway Patrol
- Tim Roach – TSP
- Bob King – TSP
- Todd Schultz - TSP

The purpose of the meeting was to gain initial insights from the SDDOT maintenance team about the operation, history, and condition of the existing on-site facilities at the Valley Springs POE rest area. The following summarizes the key points of the meeting:

FACILITY USE

- The site supports outdoor truck inspections and scales which, and also includes employee parking and State Police parking. There is a consistent year round 24 hours use of the facilities for inspections and for the police functions, but it as an inspection facility it isn't always open. The site size is sufficient for the current needs as there aren't any extreme periods in truck traffic, the quantity of which is more impacted by economics, or weather. It also doesn't appear the current staffing levels will be much impacted for the long-term as traffic/use increases.
- The properties as a whole are uniquely shared with the SDDOT rest area located behind the site. This rest area has consistent flow of travelers all year peaking in the summer months. Highway access and egress to and from both facilities is shared, which creates costly confusion and problems for the POE, and for truckers.
- Truckers do spend the night in their rigs at this location as it is safe with the presence of the Police. The site is most active when bad weather hits and they will stay their during highway closures. There is sufficient space on the site for these functions.
- The facility is small (900sf), worn down, unsightly, and undersized for its current use. It was originally designed for the truck scales function. It also now houses the State Police inspections function, and as a small highway operations center. It has no real space to support these functions and there are insufficient accommodations.

- As no facilities are provided for the truckers at the POE building, they typically walk about 100 yards over from the POE.

USER INFORMATION

- The building interior supports three main functions. The primary function of the facility is to support the scales team which observes and weighs truck passing through on outside scales, and coordinates the paperwork with riders in the waiting area. These roles are supported mostly by citizen employees. The remaining functions are provided by the SD Highway Patrol which supports the outdoor inspections of trucks, and to manage police highway crews that operate from the facility.

FACILITY NEEDS / ISSUES

- There a couple of critical issues at this location.
- As the site ramp entrance and exit is shared with the separate POE, Truck and Camper parking and access is confusing, and is an issue which needs to be further reviewed and addressed. The shared vehicle entrance ramp concept is fairly unique and unexpected which a main cause of problems as truckers often bypass the POE unintentionally. Or, they upon entering the site often mistakenly enter the visitor center entrance and have no way to get back to the POE. They then require an escort to proceed forward on the highway, turn around and return.
- For a multitude of reasons, the Police would like to see facility inspection function placed indoors as is in other facilities and for their operations as a whole to be physically separated from the visitor center.
- The building structure appears to be noticeably undersized for its current use. It has a small office, a scale operations room, one restroom, a mechanical room which is also a lunchroom, a small storage room, and a small lobby (100sf). It appears as it was designed for mostly the staff associated with management of the scales. It is not currently large enough to appropriately support the needs for the State Police inspection and patrol functions. The occupants feel it needs to be at least twice the size, and a very different facility.
- The scale system sometimes freezes in the winter. This causes a shut-down of the station. A maintenance person must climb into the scale pit and apply temporary heat to the scale system to make it operational. A permanent solution should be found.
- There is no immediate safety issues reported. A video monitor system is very successful in reducing vandalism and security problems. However the system, which can be remotely accessed, is old and only about half of the cameras are in working order.
- There is no history of accidents related to current facility and on site circulation.
- Site Systems (landscaping, lighting, trash, ponds, etc.):
 - Sidewalk, stairs, and paving show signs of aging and wear, but otherwise surfaces are in good condition.
 - Lagoon System is being rebuilt at the time of this visit. Piping has not had any leaks at this time. Site is served by the same system as the rest area.
 - The domestic water supply to the building is provided from the adjacent rest stop building. It is supplied by a rural water system.
 - There are no gas lines or propane tanks – the building is heated with electric heat.
 - There is no lawn irrigation system served from this building. Some areas of the site are irrigated from a system that is located in the adjacent rest stop building.

October 15, 2013

Valley Springs POE Maintenance Review Meeting

Page 3

- Site parking, pedestrian, and exterior building lighting systems are original.
- Site drainage is excellent, and there isn't a history of ponding or flooding. Ice and water have built up in the area of the scale in the winter months.
- There is a sump pump in a manhole that serves the scale pit. The pump discharges to a ditch adjacent to the interstate roadway. The age and condition of this pump are unknown. The pump should be evaluated to see if it needs to be replaced.

- Building Systems (shell, interior finishes, MEP):
 - Upgrade to ADA requirements.
 - Replace video camera system.
 - Replace lavatory faucet with an ADA compliant faucet. Insulate or cover exposed piping below lavatory.
 - Ongoing roof leaks in main facility need final repair (5 years old but under warranty and not fixed).
 - Heating, air conditioning, and Ventilation system is not adequate and has no outside air connection for indoor air quality.
 - Electrical power upgrades seems to be adequate for the connected loads. Power system may need to be upgraded for any future additional electrical loads.
 - Interior Lighting outdated and failing – maintenance cost and problems...needs replacement.
 - There is a small bathroom exhaust fan/light that is inadequate for the room.
 - There is a small exhaust fan/light in the ceiling of the equipment room/break room. It is inoperative and is not adequate for the room.
 - Facility infrastructure is ready for a complete renovation.

SDDOT MAINTENANCE STAFF REQUESTS

- Site and Facility infrastructure is ready for a substantial and comprehensive renovation.

These meeting minutes were prepared by Tim Roach (TSP). Please contact me at roachtj@teamtsp.com or 605-343-6102 for corrections or clarifications.



The Interstate Rest Areas Study: Along the I-29 and I-90 Corridors

APPENDIX B ADA SURVEY RESULTS

SDDOT Rest Area Improvements
FHU Reference Number 13-039-01
TSP Project Number 03120855

Building **VALLEY SPRINGS POE**

Location **90 W., MRM 412**

Date **09-18-2013 (Inspection)**

ADA Checklist for Readily Achievable Barrier Removal

Priority 1 – Approach & Entrance



SDDOT Rest Area Improvements

FHU Reference Number 13-039-01

TSP Project Number 03120855

Project

Building

VALLEY SPRINGS POE

Location

90 W., MRM 412

Date

09-18-2013 (Inspection)

Surveyors

Timothy Roach, AIA

Todd Schultz, PE

Robert King, CPD

Contact Information TSP (605) 343-6102

An accessible route from site arrival points and an accessible entrance should be provided for everyone.



Institute for Human Centered Design
www.HumanCenteredDesign.org

November 2011



ADA National Network

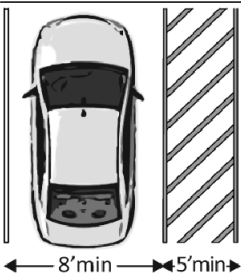
Questions on the ADA 800-949-4232 voice/tty

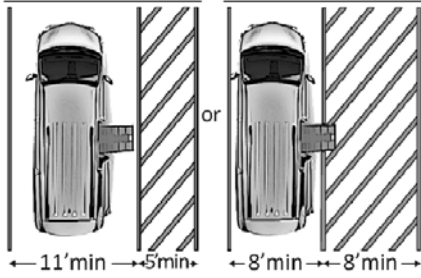
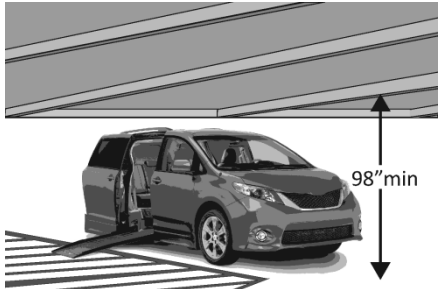
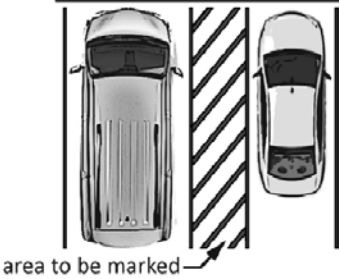
www.ADAchecklist.org


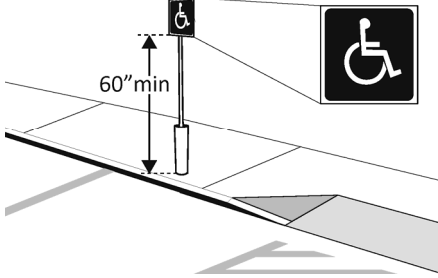


This checklist was produced by the New England ADA Center, a project of the Institute for Human Centered Design and a member of the ADA National Network. This checklist was developed under a grant from the Department of Education, NIDRR grant number H133A060092-09A. However the contents do not necessarily represent the policy of the Department of Education, and you should not assume endorsement by the Federal Government.

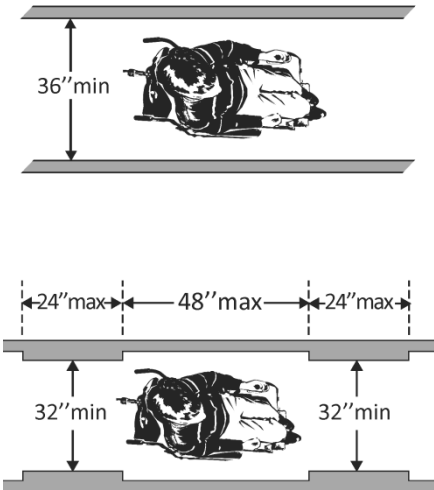
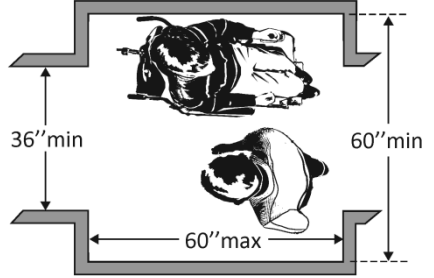
Questions or comments on the checklist contact the New England ADA Center at 617-695-0085 voice/tty or ADAinfo@NewEnglandADA.org

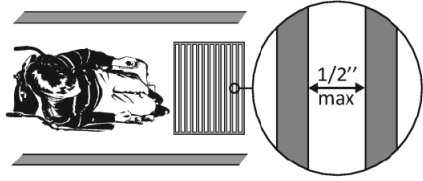
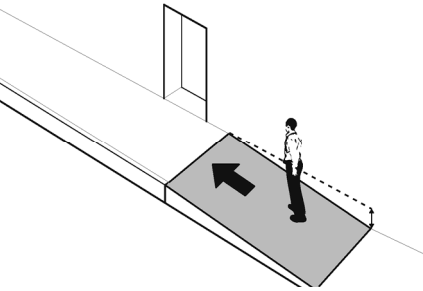
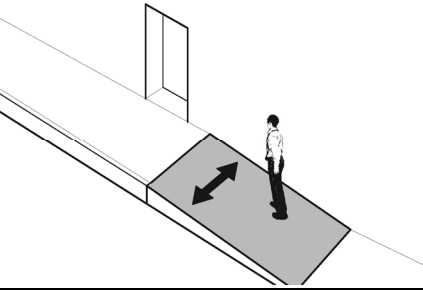
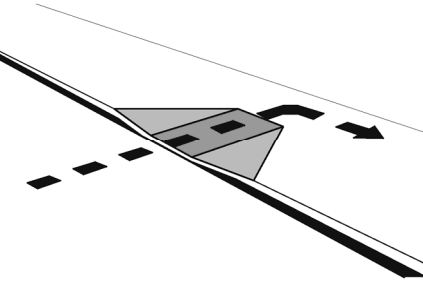
For the full set of checklists, including the checklists for recreation facilities visit www.ADAchecklist.org.

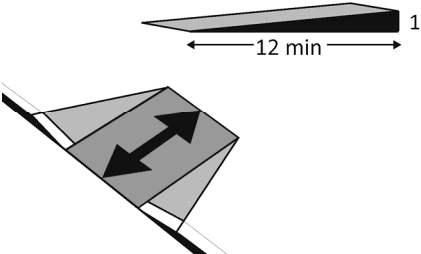
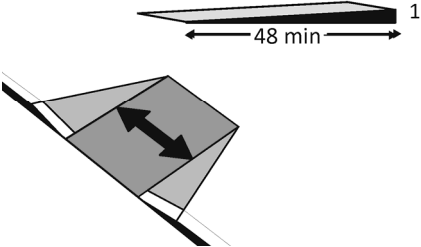
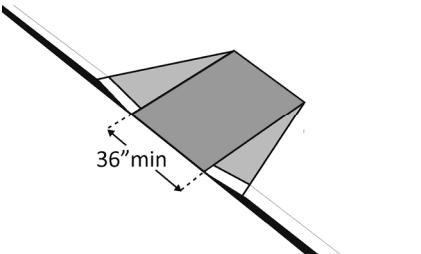
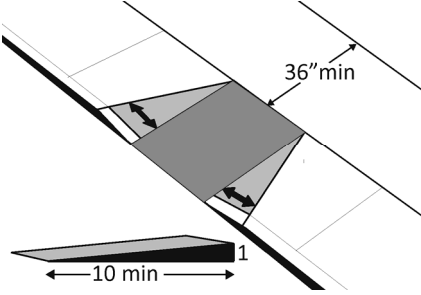
Priority 1 – Approach & Entrance		Comments	Possible Solutions												
<p>1.1 Is there at least one route from site arrival points (parking, passenger loading zones, public sidewalks and public transportation stops) that does not require the use of stairs?</p>	<p><input checked="" type="checkbox"/> Yes <input type="checkbox"/> No</p> <p>If yes, location of route:</p>	<p>EAST AND WEST SIDES</p> <p>Photo #: 1.1</p>	<ul style="list-style-type: none"> • Add a ramp • Regrade to 1:20 maximum slope • Add a lift if site constraints prevent other solutions 												
<p>Parking (2010 Standards – 208 & 502) Note: Accessible parking spaces should be identified by size, access aisle and signage.</p>															
<p>1.2 If parking is provided for the public, are an adequate number of accessible spaces provided?</p>	<p><input type="checkbox"/> Yes <input checked="" type="checkbox"/> No</p> <p>Total #: 7</p> <p>Accessible #: 0</p>	<table border="1"> <thead> <tr> <th>Total Spaces</th> <th>Accessible Spaces</th> </tr> </thead> <tbody> <tr> <td>1 - 25</td> <td>1</td> </tr> <tr> <td>26 - 50</td> <td>2</td> </tr> <tr> <td>51 - 75</td> <td>3</td> </tr> <tr> <td>76 - 100</td> <td>4</td> </tr> <tr> <td colspan="2">100+ see 2010 Standards 208.2</td> </tr> </tbody> </table> <p>Photo #: 1.2</p>	Total Spaces	Accessible Spaces	1 - 25	1	26 - 50	2	51 - 75	3	76 - 100	4	100+ see 2010 Standards 208.2		<ul style="list-style-type: none"> • Reconfigure by repainting lines • •
Total Spaces	Accessible Spaces														
1 - 25	1														
26 - 50	2														
51 - 75	3														
76 - 100	4														
100+ see 2010 Standards 208.2															
<p>1.3 Of the accessible spaces, is at least one a van accessible space?*</p>	<p><input type="checkbox"/> Yes <input checked="" type="checkbox"/> No</p>	<p>*For every 6 or fraction of 6 parking spaces required by the table above, at least 1 should be a van accessible space.</p> <p>Photo #: 1.1</p>	<p>* If constructed before 3/15/2012, parking is compliant if at least 1 in every 8 accessible spaces is van accessible</p> <ul style="list-style-type: none"> • Reconfigure by repainting lines 												
<p>1.4 Are accessible spaces at least 8 feet wide with an access aisle at least 5 feet wide?</p>	<p><input type="checkbox"/> Yes <input type="checkbox"/> No</p> <p>Measurement:</p>	 <p>Photo #: 1.2</p>	<ul style="list-style-type: none"> • Reconfigure by repainting lines <p>Two spaces can share an access aisle (check state requirements; some states, such as Connecticut, require an access aisle for each space)</p>												

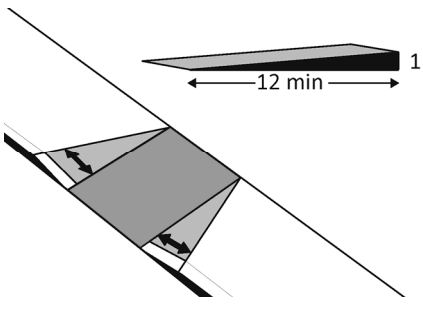
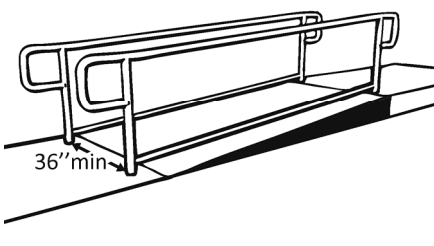
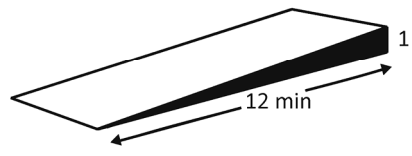
<p>1.5 Is the van accessible space: At least 11 feet wide with an access aisle at least 5 feet wide? Or At least 8 feet wide with an access aisle at least 8 feet wide?</p>	<p><input type="checkbox"/> Yes <input type="checkbox"/> No Measurement: <input type="checkbox"/> Yes <input type="checkbox"/> No Measurement:</p>		<p style="text-align: center;">NA</p> <p>Photo #: 1.2</p>	<ul style="list-style-type: none"> • Reconfigure to provide van-accessible space(s) • •
<p>1.6 Is at least 98 inches of vertical clearance provided for the van accessible space?</p>	<p><input type="checkbox"/> Yes <input type="checkbox"/> No Measurement:</p>		<p style="text-align: center;">NA</p> <p>Photo #:</p>	<ul style="list-style-type: none"> • Reconfigure to provide van-accessible space(s) • •
<p>1.7 Are the access aisles marked so as to discourage parking in them?</p>	<p><input type="checkbox"/> Yes <input type="checkbox"/> No</p>		<p style="text-align: center;">NA</p> <p>Photo #: 1.2</p>	<ul style="list-style-type: none"> • Mark access aisles • • <p>The marking method and color may be addressed by state/local requirements</p>
<p>1.8 Is the slope of the accessible parking spaces and access aisles no steeper than 1:48 in all directions?</p>	<p><input type="checkbox"/> Yes <input type="checkbox"/> No Measurement:</p>		<p style="text-align: center;">SLOPES AROUND BUILDING WOULD MOST LIKELY QUALIFY AS <2%</p> <p style="text-align: center;">NA</p> <p>Photo #:</p>	<ul style="list-style-type: none"> • Regrade surface • •

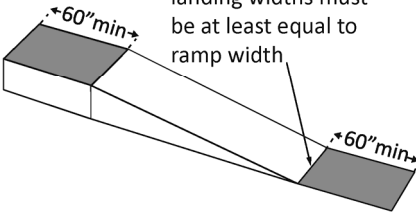
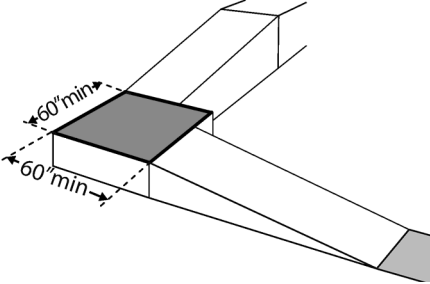
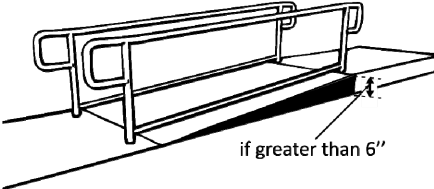
<p>1.9 Do the access aisles adjoin an accessible route?</p>	<p><input type="checkbox"/> Yes <input type="checkbox"/> No</p>		<p style="text-align: center;">NA</p> <p>Photo #: 1.2</p>	<ul style="list-style-type: none"> • Create accessible route • Relocate accessible space •
<p>1.10 Are accessible spaces Identified with a sign that includes the International Symbol of Accessibility?</p> <p>Is the bottom of the sign at least 60 inches above the ground?</p>	<p><input type="checkbox"/> Yes <input type="checkbox"/> No</p> <p><input type="checkbox"/> Yes <input type="checkbox"/> No</p> <p>Measurement:</p>		<p style="text-align: center;">NA</p> <p>Photo #:</p>	<ul style="list-style-type: none"> • Install signs • • <p>The International Symbol of Accessibility is not required on the ground by the 2010 Standards</p>
<p>1.11 Are there signs reading “van accessible” at van accessible spaces?</p>	<p><input type="checkbox"/> Yes <input type="checkbox"/> No</p>		<p style="text-align: center;">NA</p> <p>Photo #:</p>	<ul style="list-style-type: none"> • Install signs • •
<p>1.12 Of the total parking spaces, are the accessible spaces located on the closest accessible route to the accessible entrance(s)?</p>	<p><input type="checkbox"/> Yes <input type="checkbox"/> No</p>		<p style="text-align: center;">NA</p> <p>Photo #: 1.2</p>	<ul style="list-style-type: none"> • Reconfigure spaces • • <p>If parking lot serves multiple entrances, accessible parking should be dispersed</p>

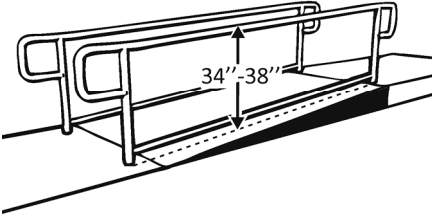
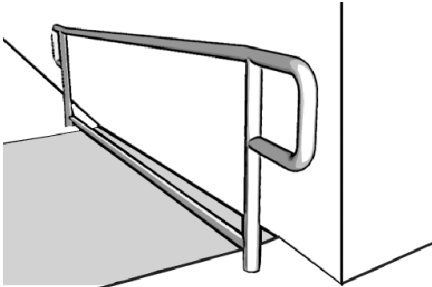
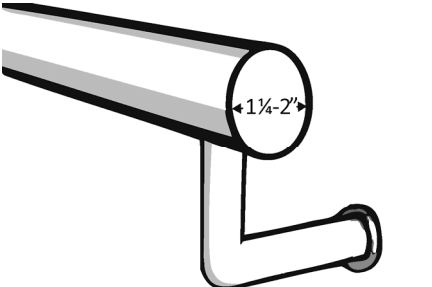
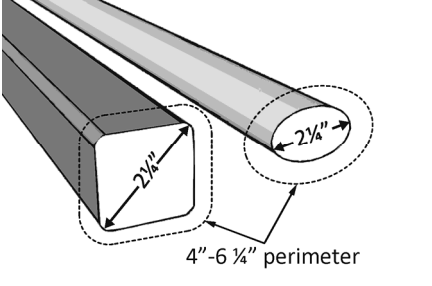
Exterior Accessible Route (2010 Standards – Ch.4)				
<p>1.13 Is the route stable, firm and slip-resistant?</p>	<p><input checked="" type="checkbox"/> Yes <input type="checkbox"/> No</p>		<p>Photo #: 1.13</p>	<ul style="list-style-type: none"> • Repair uneven paving • Fill small bumps and breaks with patches • Replace gravel with asphalt or other surface
<p>1.14 Is the route at least 36 inches wide?</p> <p>Note: The accessible route can narrow to 32 inches min. for a max. of 24 inches. These narrower portions of the route must be at least 48 inches from each other.</p>	<p><input checked="" type="checkbox"/> Yes <input type="checkbox"/> No</p> <p>Measurement: 73"</p>		<p>Photo #: 1.13</p>	<ul style="list-style-type: none"> • Change or move landscaping, furnishings or other items • Widen route •
<p>1.15 If the route is greater than 200 feet in length and no less than 60 inches wide, is there a passing space no less than 60 x 60 inches?</p>	<p><input type="checkbox"/> Yes <input type="checkbox"/> No</p> <p>Measurement:</p>		<p>NA</p> <p>Photo #:</p>	<ul style="list-style-type: none"> • Widen route for passing space • •

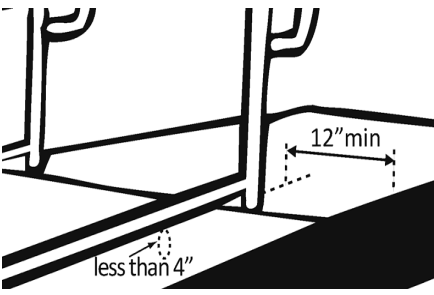
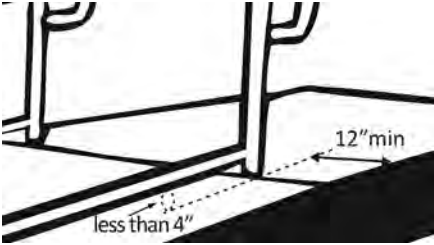
<p>1.16 If there are grates or openings on the route, are the openings no larger than ½ inches to the dominant direction of travel?</p> <p>Is the long dimension perpendicular to the dominant direction of travel?</p>	<p><input type="checkbox"/> Yes <input type="checkbox"/> No</p> <p>Measurement:</p> <p><input type="checkbox"/> Yes <input type="checkbox"/> No</p>		<p style="text-align: center; color: red; font-weight: bold;">NA</p> <p>Photo #:</p>	<ul style="list-style-type: none"> • Replace or move grate • •
<p>1.17 Is the running slope no steeper than 1:20, i.e. for every inch of height change there are at least 20 inches of route run?</p>	<p><input checked="" type="checkbox"/> Yes <input type="checkbox"/> No</p> <p>Measurement:</p>		<p style="color: red; font-weight: bold;"><5% slope</p> <p>Photo #:</p>	<ul style="list-style-type: none"> • Regrade to 1:20 max. • If steeper than 1:20 and no steeper than 1:12, treat as a ramp and add other features such as edge protection and handrails •
<p>1.18 Is the cross slope no steeper than 1:48?</p>	<p><input checked="" type="checkbox"/> Yes <input type="checkbox"/> No</p> <p>Measurement:</p>		<p>Photo #:</p>	<ul style="list-style-type: none"> • Regrade to 1:48 max. • •
<p>Curb Ramps (2010 Standards – 406)</p>				
<p>1.19 If the accessible route crosses a curb, is there a curb ramp?</p>	<p><input type="checkbox"/> Yes <input checked="" type="checkbox"/> No</p>		<p>Photo #: 1.13</p>	<ul style="list-style-type: none"> • Install curb ramp • •




<p>1.20 Is the running slope of the curb ramp no steeper than 1:12, i.e. for every inch of height change there are at least 12 inches of curb ramp run?</p>	<p><input type="checkbox"/> Yes <input type="checkbox"/> No</p> <p>Measurement:</p>		<p style="text-align: center;">NA</p> <p>Photo #:</p>	<ul style="list-style-type: none"> • Regrade curb ramp • •
<p>1.21 Is the cross slope of the curb ramp, excluding flares, no steeper than 1:48?</p>	<p><input type="checkbox"/> Yes <input type="checkbox"/> No</p> <p>Measurement:</p>		<p style="text-align: center;">NA</p> <p>Photo #:</p>	<ul style="list-style-type: none"> • Regrade curb ramp • •
<p>1.22 Is the curb ramp, excluding flares, at least 36 inches wide?</p>	<p><input type="checkbox"/> Yes <input type="checkbox"/> No</p> <p>Measurement:</p>		<p style="text-align: center;">NA</p> <p>Photo #:</p>	<ul style="list-style-type: none"> • Widen curb ramp • •
<p>1.23 At the top of the curb ramp is there a level landing (slope no steeper than 1:48 in all directions) that is at least 36 inches long and at least as wide as the curb ramp? If there are curb ramp flares, are the slopes of the flares no steeper than 1:10, i.e. for every inch of height change there are</p>	<p><input type="checkbox"/> Yes <input type="checkbox"/> No</p> <p>Measurement:</p> <p><input type="checkbox"/> Yes <input type="checkbox"/> No</p> <p>Measurement:</p>		<p style="text-align: center;">NA</p> <p>Photo #:</p>	<ul style="list-style-type: none"> • Reconfigure • Add ramp flares •

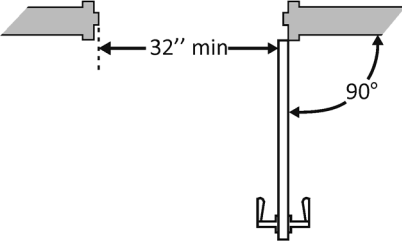
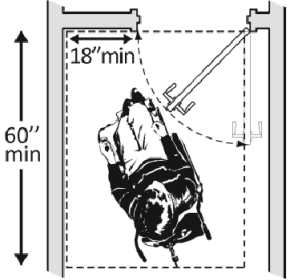
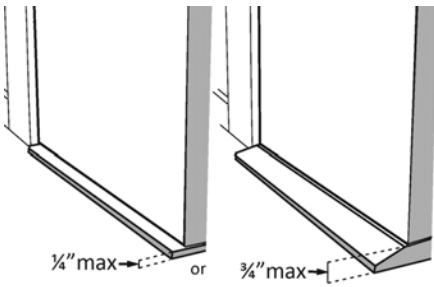
<p>at least 10 inches of flare run?</p>			<p>Photo #:</p>	
<p>1.24 If the landing at the top is less than 36 inches long, are there curb ramp flares?</p> <p>Are the slopes of the flares no greater than 1:12, i.e. for every inch of height change there are at least 12 inches of flare run?</p>	<p><input type="checkbox"/> Yes <input type="checkbox"/> No</p> <p><input type="checkbox"/> Yes <input type="checkbox"/> No</p> <p>Measurement:</p>		<p>NA</p> <p>Photo #:</p>	<ul style="list-style-type: none"> • Add ramp flares • Regrade flares •
<p>Ramps (2010 Standards – 405 & 505) Note: If any portion of the accessible route is steeper than 1:20, it should be treated as a ramp.</p>				
<p>1.25 If there is a ramp (other than curb ramps), is it at least 36 inches wide? If there are handrails, measure between the handrails.</p>	<p><input checked="" type="checkbox"/> Yes <input type="checkbox"/> No</p> <p>Measurement:</p> <p>73"</p>		<p>Photo #: 1.13</p>	<ul style="list-style-type: none"> • Alter ramp • •
<p>1.26 Is the surface stable, firm and slip resistant?</p>	<p><input checked="" type="checkbox"/> Yes <input type="checkbox"/> No</p>		<p>Photo #: 1.1</p>	<ul style="list-style-type: none"> • Resurface ramp • •
<p>1.27 For each section of the ramp, is the running slope no greater than 1:12, i.e. for every inch of height change there are at least 12 inches of ramp run?</p> <p>Note: Rises no greater than 3 inches with a slope no steeper than</p>	<p><input type="checkbox"/> Yes <input type="checkbox"/> No</p> <p>Measurement:</p>		<p>ONLY APPLIES TO WEST SIDE – RAMP SHOULD BE UPGRADED TO ADA REQUIREMENTS</p> <p>Photo #:</p>	<ul style="list-style-type: none"> • Alter or relocate ramp • Lengthen ramp to decrease slope •

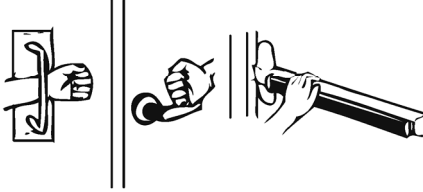
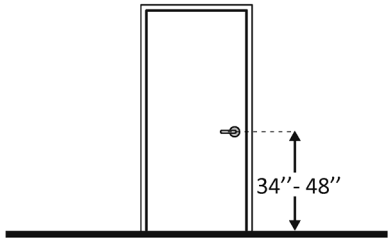
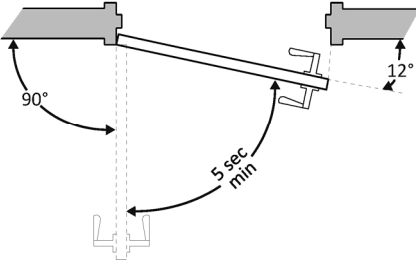
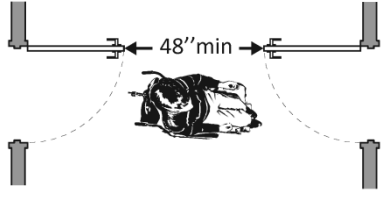

<p>1:8 and rises no greater than 6 inches with a slope no steeper than 1:10 are permitted when such slopes are necessary due to space limitations.</p>			<p>Photo #:</p>	
<p>1.28 Is there a level landing that is at least 60 inches long and at least as wide as the ramp:</p> <p>At the top of the ramp?</p> <p>At the bottom of the ramp?</p>	<p><input checked="" type="checkbox"/> Yes <input type="checkbox"/> No</p> <p>Measurement:</p> <p><input checked="" type="checkbox"/> Yes <input type="checkbox"/> No</p> <p>Measurement:</p>		<p>Photo #:</p>	<ul style="list-style-type: none"> • Alter ramp • •
<p>1.29 Is there a level landing where the ramp changes direction that is at least 60 x 60 inches?</p>	<p><input type="checkbox"/> Yes <input type="checkbox"/> No</p> <p>Measurement:</p>		<p style="text-align: center;">NA</p> <p>Photo #:</p>	<ul style="list-style-type: none"> • Alter ramp • •
<p>1.30 If the ramp has a rise higher than 6 inches, are there handrails on both sides?</p>	<p><input type="checkbox"/> Yes <input checked="" type="checkbox"/> No</p> <p>Measurement:</p>		<p>Photo #: 1.13</p>	<ul style="list-style-type: none"> • Add handrails • • <p>Curb ramps are not required to have handrails</p>

<p>1.31 Is the top of the handrail gripping surface no less than 34 inches and no greater than 38 inches above the ramp surface?</p>	<p><input type="checkbox"/> Yes <input checked="" type="checkbox"/> No</p> <p>Measurement: 33 ½"</p>		<p>Photo #: 1.31</p>	<ul style="list-style-type: none"> • Reconfigure or replace handrails • •
<p>1.32 Is the handrail gripping surface continuous and not obstructed along the top or sides?</p> <p>Is the bottom of the handrail gripping surface obstructed for no more than 20 percent of its length?</p>	<p><input checked="" type="checkbox"/> Yes <input type="checkbox"/> No</p> <p><input checked="" type="checkbox"/> Yes <input type="checkbox"/> No</p> <p>Measurement:</p>		<p>16" OBSTRUCTION 330" LENGTH</p> <p>Photo #: 1.31</p>	<ul style="list-style-type: none"> • Reconfigure or replace handrails • •
<p>1.33 If the handrail gripping surface is circular, is it no less than 1 ¼ inches and no greater than 2 inches in diameter?</p>	<p><input checked="" type="checkbox"/> Yes <input type="checkbox"/> No</p> <p>Measurement: 2" DIAMETER</p>		<p>Photo #: 1.31</p>	<ul style="list-style-type: none"> • Replace handrails • •
<p>1.34 If the handrail gripping surface is non-circular, is it no less than 4 inches and no greater than 6 ½ inches in perimeter and no more than 2 ¼ inches in cross section?</p>	<p><input type="checkbox"/> Yes <input type="checkbox"/> No</p> <p>Measurement:</p>		<p>NA</p> <p>1.31 Photo #:</p>	<ul style="list-style-type: none"> • Replace handrails • •

<p>1.35 Does the handrail:</p> <p>Extend at least 12 inches horizontally beyond the top and bottom of the ramp?</p> <p>Return to a wall, guard, or landing surface?</p>	<p><input type="checkbox"/> Yes <input checked="" type="checkbox"/> No</p> <p>Measurement: 0</p> <p><input type="checkbox"/> Yes <input checked="" type="checkbox"/> No</p>		<p>Photo #: 1.13</p>	<ul style="list-style-type: none"> • Add extensions • Reconfigure handrails •
<p>1.36 To prevent wheelchair casters and crutch tips from falling off:</p> <p>Does the surface of the ramp extend at least 12 inches beyond the inside face of the handrail?</p> <p>Or</p> <p>Is there a curb or barrier that prevents the passage of a 4-inch diameter sphere?</p>	<p><input type="checkbox"/> Yes <input checked="" type="checkbox"/> No</p> <p>Measurement: 5"</p> <p><input type="checkbox"/> Yes <input checked="" type="checkbox"/> No</p> <p>Measurement: 0</p>		<p>Photo #: 1.31</p>	<ul style="list-style-type: none"> • Add curb • Add barrier • Extend ramp width •
<p>Entrance (2010 Standards – 404)</p>				
<p>1.37 Is the main entrance accessible?</p>	<p><input checked="" type="checkbox"/> Yes <input type="checkbox"/> No</p>		<p>Photo #:</p>	<ul style="list-style-type: none"> • Redesign to make it accessible • •

<p>1.38 If the main entrance is not accessible, is there an alternative accessible entrance?</p> <p>Can the alternative accessible entrance be used independently and during the same hours as the main entrance?</p>	<p><input type="checkbox"/> Yes <input type="checkbox"/> No</p> <p><input type="checkbox"/> Yes <input type="checkbox"/> No</p>		<p style="text-align: center; color: red; font-weight: bold;">NA</p> <p>Photo #:</p>	<ul style="list-style-type: none"> • Designate an entrance and make it accessible • Ensure that accessible entrance can be used independently and during the same hours as the main entrance •
<p>1.39 Do all inaccessible entrances have signs indicating the location of the nearest accessible entrance?</p>	<p><input type="checkbox"/> Yes <input checked="" type="checkbox"/> No</p>		<p style="text-align: center; color: red; font-weight: bold;">NA</p> <p>Photo #:</p>	<ul style="list-style-type: none"> • Install signs • Install signs on route before people get to inaccessible entrances so that people do not have to turn around and retrace route •
<p>1.40 If not all entrances are accessible, is there a sign at the accessible entrance with the International Symbol of Accessibility?</p>	<p><input type="checkbox"/> Yes <input type="checkbox"/> No</p>		<p style="text-align: center; color: red; font-weight: bold;">NA</p> <p>Photo #:</p>	<ul style="list-style-type: none"> • Install sign • •

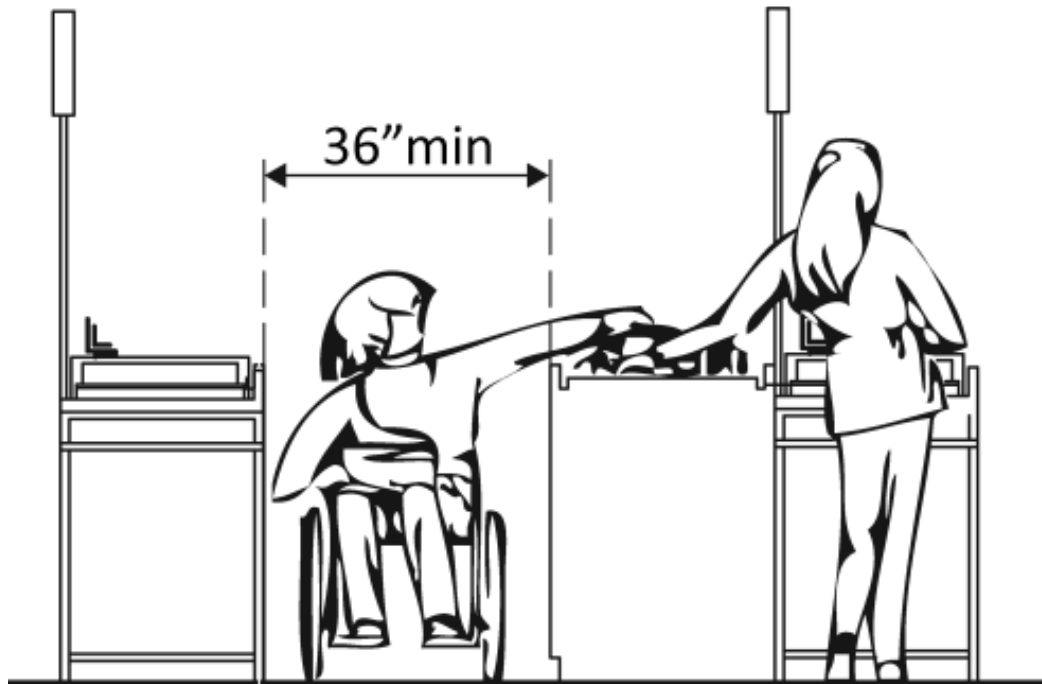
<p>1.41 Is the clear opening width of the accessible entrance door at least 32 inches, between the face of the door and the stop, when the door is open 90 degrees?</p>	<p><input checked="" type="checkbox"/> Yes <input type="checkbox"/> No</p> <p>Measurement:</p> <p>34"</p>		<p>Photo #: 1.41</p>	<ul style="list-style-type: none"> • Alter door • Install offset hinges •
<p>1.42 If there is a front approach to the pull side of the door, is there at least 18 inches of maneuvering clearance beyond the latch side plus at least 60 inches clear depth?</p> <p>On both sides of the door, is the ground or floor surface of the maneuvering clearance level (no steeper than 1:48)?</p>	<p><input checked="" type="checkbox"/> Yes <input type="checkbox"/> No</p> <p>Measurement:</p> <p>48"</p> <p><input checked="" type="checkbox"/> Yes <input type="checkbox"/> No</p> <p>Measurement:</p>		<p>Photo #: 1.41</p>	<p>See 2010 Standards 404.2.4 for maneuvering clearance requirements on the push side of the door and side approaches to the pull side of the door</p> <ul style="list-style-type: none"> • Remove obstructions • Reconfigure walls • Add automatic door opener
<p>1.43 Is the door threshold edge no more than ¼ inch high?</p> <p>Or</p> <p>No more than ¾ inch high if slope is beveled no steeper than 1:2?</p> <p>Note: The first ¼ inch of the threshold may be vertical; the rest must be beveled.</p>	<p><input type="checkbox"/> Yes <input checked="" type="checkbox"/> No</p> <p>Measurement:</p> <p>3"</p> <p><input type="checkbox"/> Yes <input checked="" type="checkbox"/> No</p> <p>Measurement:</p> <p>3"</p>		<p>Photo #: 1.41</p>	<ul style="list-style-type: none"> • Remove or replace threshold • •

<p>1.44 Is the door equipped with hardware, including locks, that is operable with one hand and does not require tight grasping, pinching, or twisting of the wrist?</p>	<p><input type="checkbox"/> Yes <input checked="" type="checkbox"/> No</p>		<p>Photo #: 1.41</p>	<ul style="list-style-type: none"> • Replace inaccessible knob with lever, loop or push hardware • Add automatic door opener •
<p>1.45 Are the operable parts of the door hardware no less than 34 inches and no greater than 48 inches above the floor or ground surface?</p>	<p><input checked="" type="checkbox"/> Yes <input type="checkbox"/> No</p> <p>Measurement: 42"</p>		<p>Photo #: 1.41</p>	<ul style="list-style-type: none"> • Change hardware height • •
<p>1.46 If the door has a closer, does it take at least 5 seconds to close from an open position of 90 degrees to a position of 12 degrees from the latch?</p>	<p><input type="checkbox"/> Yes <input checked="" type="checkbox"/> No</p> <p>Measurement:</p>		<p>Photo #: 1.41</p>	<ul style="list-style-type: none"> • Adjust closer • •
<p>1.47 If there are two doors in a series, e.g. vestibule, is the distance between the doors at least 48 inches plus the width of the doors when swinging into the space?</p>	<p><input type="checkbox"/> Yes <input type="checkbox"/> No</p> <p>Measurement:</p>	 <p style="text-align: center;">or</p> 	<p style="text-align: center;">NA</p>	<ul style="list-style-type: none"> • Remove inner door • Change door swing •

		<p style="text-align: center;">48" min</p> <p style="text-align: center;">or</p> <p style="text-align: center;">48" min</p>	<p>Photo #:</p>	
<p>1.48 If provided at the building entrance, are carpets or mats no higher than ½ inch thick?</p>	<p><input type="checkbox"/> Yes <input type="checkbox"/> No</p> <p>Measurement:</p>	<p style="text-align: center;">½" max</p>	<p style="text-align: center; color: red;">NA</p> <p>Photo #:</p>	<ul style="list-style-type: none"> • Replace or remove mats • •
<p>1.49 Are edges of carpets or mats securely attached to minimize tripping hazards?</p>	<p><input type="checkbox"/> Yes <input type="checkbox"/> No</p>		<p style="text-align: center; color: red;">NA</p> <p>Photo #:</p>	<ul style="list-style-type: none"> • Secure carpeting or mats at edges • •

ADA Checklist for Readily Achievable Barrier Removal

Priority 2 – Access to Goods & Services



Project **SDDOT Rest Area Improvements**
FHU Reference Number 13-039-01
TSP Project Number 03120855

Building **VALLEY SPRINGS POE**

Location **90 W., MRM 412**

Date **09-18-2013 (Inspection)**

Surveyors **Timothy Roach, AIA**
Todd Schultz, PE

Robert King, CPD

Contact Information **TSP – (605) 343-6102**

The layout of the building should allow people with disabilities to obtain goods and services and to participate in activities without assistance.



Institute for Human Centered Design
www.HumanCenteredDesign.org

November 2011



ADA National Network
Questions on the ADA 800-949-4232 voice/tty

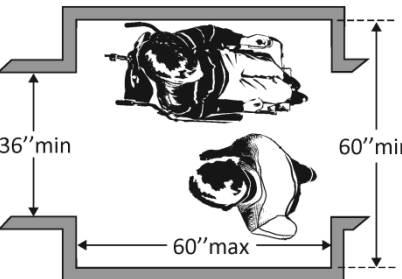
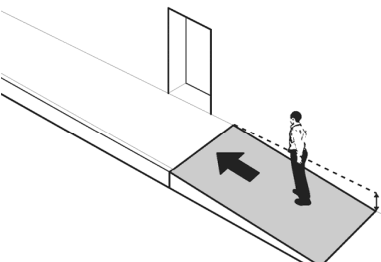
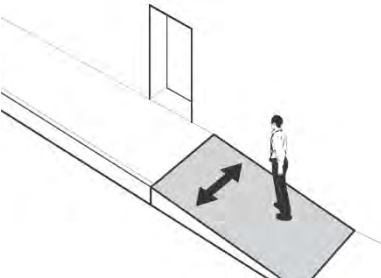

www.ADAchecklist.org

This checklist was produced by the New England ADA Center, a project of the Institute for Human Centered Design and a member of the ADA National Network. This checklist was developed under a grant from the Department of Education, NIDRR grant number H133A060092-09A. However the contents do not necessarily represent the policy of the Department of Education, and you should not assume endorsement by the Federal Government.

Questions or comments on the checklist contact the New England ADA Center at 617-695-0085 voice/tty or ADAinfo@NewEnglandADA.org

For the full set of checklists, including the checklists for recreation facilities visit www.ADAchecklist.org.

Priority 2 – Access to Goods & Services		Comments	Possible Solutions
<p>2.1 Does the accessible entrance provide direct access to the main floor, lobby and elevator?</p>	<p><input checked="" type="checkbox"/> Yes <input type="checkbox"/> No</p>	<p>Photo #: 2.1</p>	<ul style="list-style-type: none"> • Create accessible route • •
Interior Accessible Route (2010 Standards – Ch.4)			
<p>2.2 Are all public spaces on at least one accessible route?</p>	<p><input checked="" type="checkbox"/> Yes <input type="checkbox"/> No</p>	<p>Photo #:</p>	<ul style="list-style-type: none"> • Create accessible route • •
<p>2.3 Is the route stable, firm and slip-resistant?</p>	<p><input checked="" type="checkbox"/> Yes <input type="checkbox"/> No</p>	<p>Photo #:</p>	<ul style="list-style-type: none"> • Repair uneven surfaces • •
<p>2.4 Is the route at least 36 inches wide?</p> <p>Note: The accessible route can narrow to 32 inches min. for a max. of 24 inches. These narrower portions of the route must be at least 48 inches from each other.</p>	<p><input checked="" type="checkbox"/> Yes <input type="checkbox"/> No</p> <p>Measurement:</p>	<p>36" min</p> <p>24" max 48" max 24" max</p> <p>32" min 32" min</p>	<p>Photo #: 2.1</p> <ul style="list-style-type: none"> • Widen route • •

<p>2.5 If the route is greater than 200 feet in length and no less than 36 inches wide, is there a passing space no less than 60 x 60 inches?</p>	<p><input type="checkbox"/> Yes <input type="checkbox"/> No</p> <p>Measurement:</p>		<p style="text-align: center;">NA</p> <p>Photo #:</p>	<ul style="list-style-type: none"> • Widen route for passing space • •
<p>2.6 Is the running slope no steeper than 1:20, i.e. for every inch of height change there are at least 20 inches of route run?</p>	<p><input type="checkbox"/> Yes <input type="checkbox"/> No</p> <p>Measurement:</p>		<p style="text-align: center;">NA</p> <p>Photo #:</p>	<ul style="list-style-type: none"> • Regrade • If steeper than 1:20 and no steeper than 1:12, treat as ramp and add other features such as edge protection and handrails •
<p>2.7 Is the cross slope no steeper than 1:48?</p>	<p><input type="checkbox"/> Yes <input type="checkbox"/> No</p> <p>Measurement:</p>		<p style="text-align: center;">NA</p> <p>Photo #:</p>	<ul style="list-style-type: none"> • Regrade • •
<p>2.8 Do all objects on circulation paths through public areas, e.g. fire extinguishers, drinking fountains, signs, etc., protrude no more than 4 inches into the path? Or If an object protrudes more than 4 inches, is the bottom leading edge at 27 inches or lower above the floor?</p>	<p><input type="checkbox"/> Yes <input checked="" type="checkbox"/> No</p> <p>Measurement: 18" WATER DISPENSER</p> <p><input type="checkbox"/> Yes <input checked="" type="checkbox"/> No</p> <p>Measurement: ON FLOOR</p>	 <p style="text-align: center;">Or</p>	<p style="text-align: center;">NA</p> <p>Photo #:</p>	<ul style="list-style-type: none"> • Remove object • Add tactile warning such as permanent planter or partial walls •

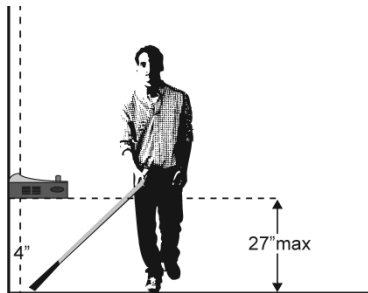
ADA Checklist for Readily Achievable Barrier Removal **Priority 2 – Access to Goods & Services**

Or
Is the bottom leading edge at 80 inches or higher above the floor?

Yes No

Measurement:

**NO
OBSTRUCTION**



Or

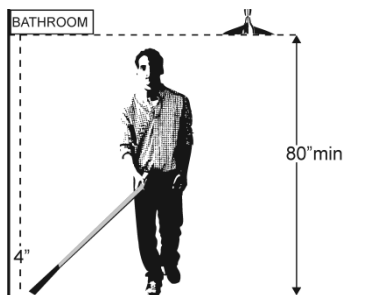
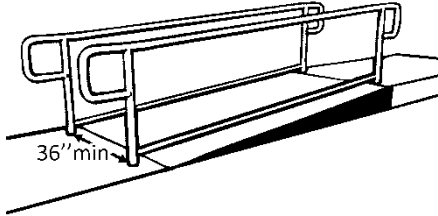
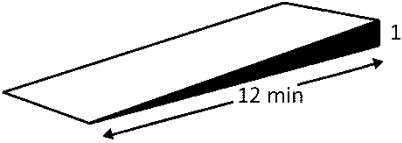


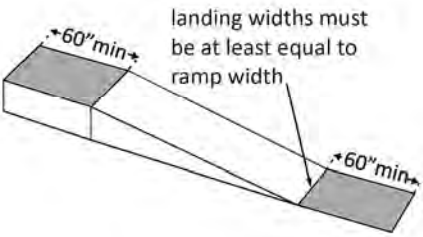
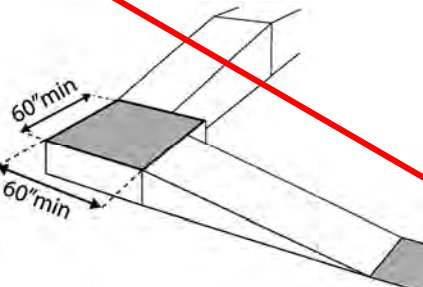
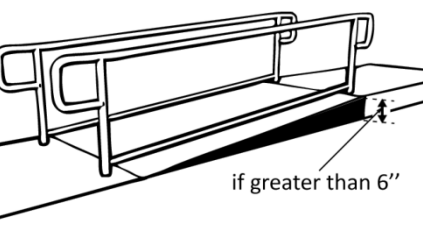
Photo #:

2.9 Are there elevators or platform lifts to all public stories?*

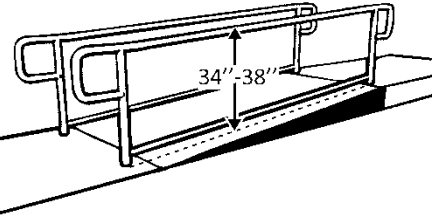
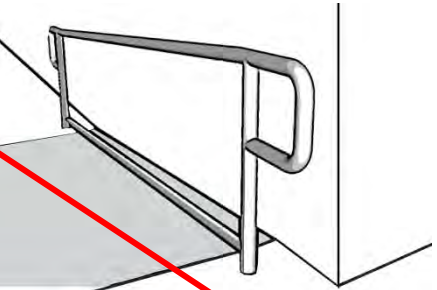
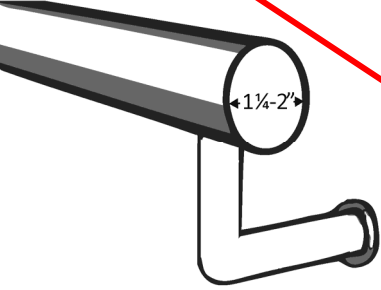
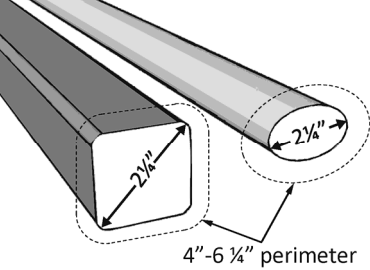
Yes No

*Vertical access is not required in new construction or alterations if a facility is less than three stories or has less than 3,000 square feet per story, unless a facility is a shopping center, shopping mall, professional office of a health care provider, transportation terminal, state facility or government facility

				<ul style="list-style-type: none"> • Install if necessary • Offer goods and services on an accessible story •
Ramps (2010 Standards 404 & 505)				
2.10 If there is a ramp, is it at least 36 inches wide? If there are handrails, measure between the handrails.	<input type="checkbox"/> Yes <input type="checkbox"/> No Measurement:		Photo #:	<ul style="list-style-type: none"> • Alter ramp • •
2.11 Is the surface stable, firm and slip resistant?	<input type="checkbox"/> Yes <input type="checkbox"/> No		Photo #:	<ul style="list-style-type: none"> • Change surface • •
2.12 For each section of the ramp, is the running slope no greater than 1:12, i.e. for every inch of height change there are at least 12 inches of ramp run? Note: Rises no greater than 3 inches with a slope no steeper than 1:8 and rises no greater than 6 inches with a slope no steeper than 1:10 are permitted when due to space limitations.	<input type="checkbox"/> Yes <input type="checkbox"/> No Measurement:		Photo #:	<ul style="list-style-type: none"> • Lengthen ramp to decrease slope • Reconfigure ramp to include switchbacks • Relocate ramp •

<p>2.13 Is there a level landing that is at least 60 inches long and at least as wide as the ramp:</p> <p>At the top of the ramp?</p> <p>At the bottom of the ramp?</p>	<p><input type="checkbox"/> Yes <input type="checkbox"/> No</p> <p>Measurement:</p> <p><input type="checkbox"/> Yes <input type="checkbox"/> No</p> <p>Measurement:</p>		<p>Photo #:</p>	<ul style="list-style-type: none"> • Alter ramp • Relocate ramp •
<p>2.14 Is there a level landing where the ramp changes direction that is at least 60 x 60 inches?</p>	<p><input type="checkbox"/> Yes <input type="checkbox"/> No</p> <p>Measurement:</p>		<p>Photo #:</p>	<ul style="list-style-type: none"> • Increase landing size • •
<p>2.15 If the ramp has a rise higher than 6 inches are there handrails on both sides?</p>	<p><input type="checkbox"/> Yes <input type="checkbox"/> No</p> <p>Measurement:</p>		<p>Photo #:</p>	<ul style="list-style-type: none"> • Add handrails • •

ADA Checklist for Readily Achievable Barrier Removal **Priority 2 – Access to Goods & Services**

<p>2.16 Is the top of the handrail gripping surface no less than 34 inches and no greater than 38 inches above the ramp surface?</p>	<p><input type="checkbox"/> Yes <input type="checkbox"/> No</p> <p>Measurement:</p>		<p>Photo #:</p>	<ul style="list-style-type: none"> • Adjust handrail height • •
<p>2.17 Is the handrail gripping surface continuous and not obstructed along the top or sides?</p> <p>If there are obstructions, is the bottom of the handrail gripping surface obstructed by no more than 20%?</p>	<p><input type="checkbox"/> Yes <input type="checkbox"/> No</p> <p><input type="checkbox"/> Yes <input type="checkbox"/> No</p> <p>Measurement:</p>		<p>Photo #:</p>	<ul style="list-style-type: none"> • Regrade to 1:20 max • If steeper than 1:20 and no steeper than 1:12, treat as a ramp and add other features such as edge protection and handrails •
<p>2.18 If the handrail gripping surface is circular, is it no less than 1 ¼ inches and no greater than 2 inches in diameter?</p>	<p><input type="checkbox"/> Yes <input type="checkbox"/> No</p> <p>Measurement:</p>		<p>Photo #:</p>	<ul style="list-style-type: none"> • Alter handrails • •
<p>2.19 If the handrail gripping surface is non-circular, is it no less than 4 inches and no greater than 6 ½ inches in perimeter and no more than 2 ¼ inches in cross section?</p>	<p><input type="checkbox"/> Yes <input type="checkbox"/> No</p> <p>Measurement:</p>		<p>Photo #:</p>	<ul style="list-style-type: none"> • Alter handrails • •

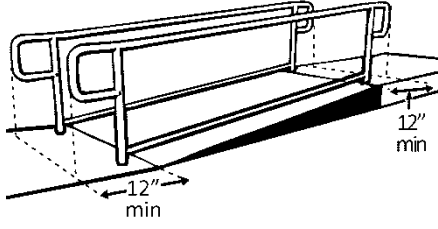
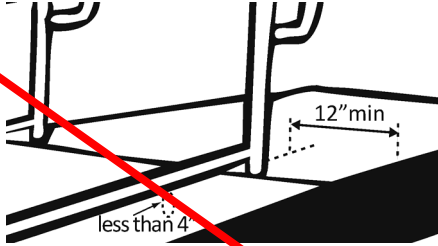
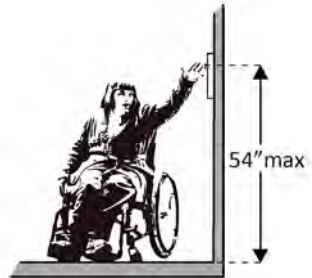
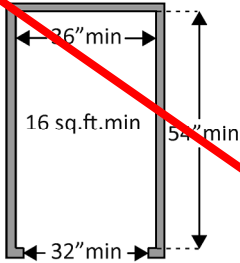
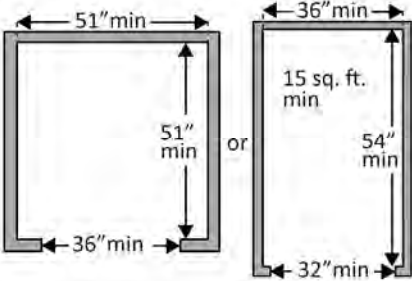
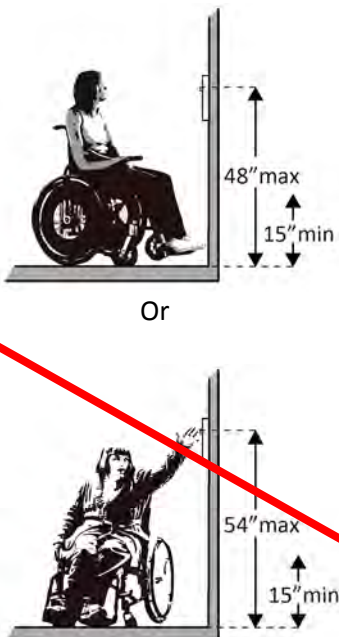

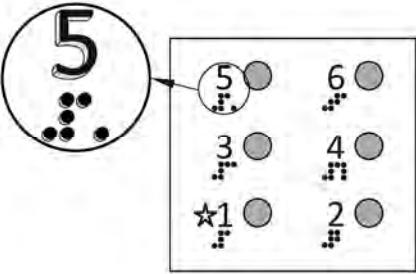
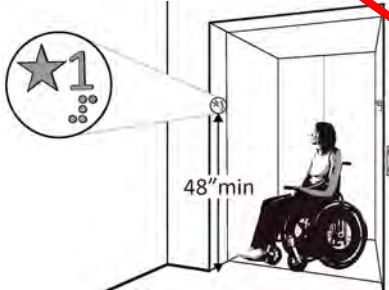
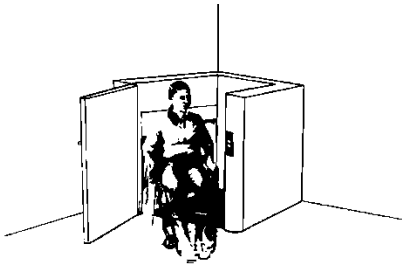
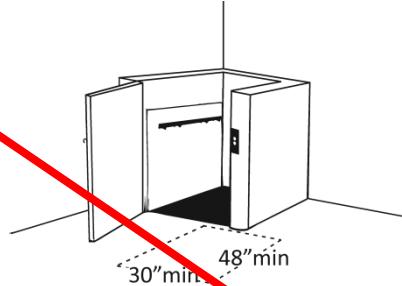
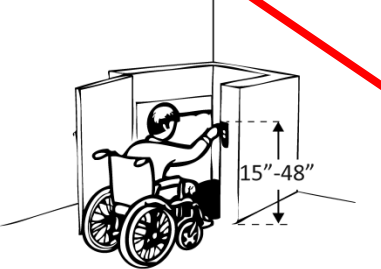
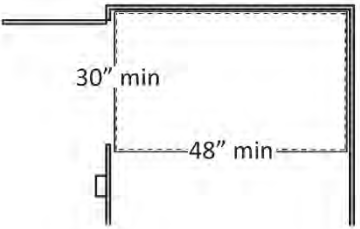
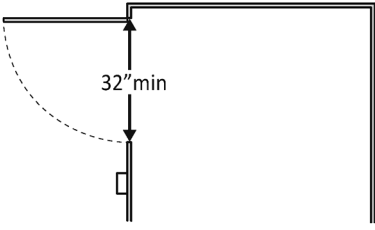
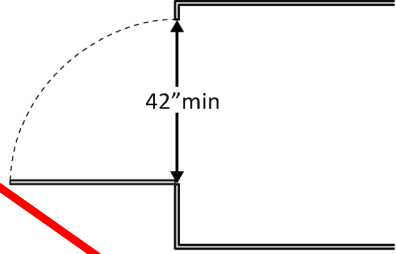
<p>2.20 Does the handrail:</p> <p>Extend at least 12 inches beyond the top and bottom of the ramp?</p> <p>Return to a wall, guard, or landing surface?</p>	<p><input type="checkbox"/> Yes <input type="checkbox"/> No</p> <p>Measurement:</p> <p><input type="checkbox"/> Yes <input type="checkbox"/> No</p>		<p>Photo #:</p>	<ul style="list-style-type: none"> • Alter handrails • • <p>If a 12" extension would be hazardous (in circulation path), it is not required</p>
<p>2.21 To prevent wheelchair casters and crutch tips from falling off:</p> <p>Does the surface of the ramp extend at least 12 inches beyond the inside face of the handrail?</p> <p>Or</p> <p>Is there a curb or barrier that prevents the passage of a 4-inch diameter sphere?</p>	<p><input type="checkbox"/> Yes <input type="checkbox"/> No</p> <p>Measurement:</p> <p><input type="checkbox"/> Yes <input type="checkbox"/> No</p> <p>Measurement:</p>		<p>Photo #:</p>	<ul style="list-style-type: none"> • Add curb • Add barrier • Extend ramp width • •
<p>Elevators – Full Size & LULA (limited use, limited application) (2010 Standards – 407 & 408) Note: LULA elevators are often used in alterations.</p>				
<p>2.22 If there is a full size or LULA elevator, are the call buttons no higher than 54 inches above the floor?</p>	<p><input type="checkbox"/> Yes <input type="checkbox"/> No</p> <p>Measurement:</p>		<p>Photo #:</p>	<ul style="list-style-type: none"> • Change call button height • •
<p>2.23 If there is a full size or LULA elevator, does the sliding door reopen automatically when obstructed by an object or person?*</p>	<p><input type="checkbox"/> Yes <input type="checkbox"/> No</p>			<p>* If constructed before 3/15/2012 and manually operated, the door is not required to reopen automatically</p>

			Photo #:	<ul style="list-style-type: none"> • Install opener •
<p>2.24 If there is a LULA elevator with a swinging door:</p> <p>Is the door power-operated?</p> <p>Does the door remain open for at least 20 seconds when activated?</p>	<p><input type="checkbox"/> Yes <input type="checkbox"/> No</p> <p><input type="checkbox"/> Yes <input type="checkbox"/> No</p> <p>Time:</p>		Photo #:	<ul style="list-style-type: none"> • Add power operated door • Adjust opening time •
<p>2.25 If there is a full size elevator:</p> <p>Is the interior at least 54 inches deep by at least 36 inches wide with at least 16 sq. ft. of clear floor area?</p> <p>Is the door opening width at least 32 inches?</p>	<p><input type="checkbox"/> Yes <input type="checkbox"/> No</p> <p>Measurement:</p> <p><input type="checkbox"/> Yes <input type="checkbox"/> No</p> <p>Measurement:</p>		Photo #:	<ul style="list-style-type: none"> • Replace elevator • •
<p>2.26 If there is a LULA elevator, is the interior:</p> <p>At least 51 x 51 inches with a door opening width of at least 36 inches?</p> <p>Or</p> <p>At least 54 inches deep by at least 36 inches wide with at least 15 sq. ft. of clear floor</p>	<p><input type="checkbox"/> Yes <input type="checkbox"/> No</p> <p>Measurement:</p> <p><input type="checkbox"/> Yes <input type="checkbox"/> No</p> <p>Measurement:</p>		Photo #:	<ul style="list-style-type: none"> • Replace elevator • •

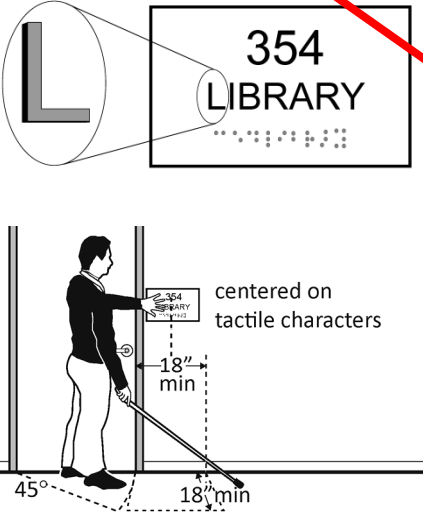
<p>area and a door opening width of at least 32 inches?</p>			Photo #:	
<p>2.27 If there is a full size or LULA elevator, are the in-car controls:</p> <p>No less than 15 inches and no greater 48 inches above the floor? Or Up to 54 inches above the floor for a parallel approach?</p>	<p><input type="checkbox"/> Yes <input type="checkbox"/> No Measurement:</p> <p><input type="checkbox"/> Yes <input type="checkbox"/> No Measurement:</p>	 <p>Or</p>	Photo #:	<ul style="list-style-type: none"> • Change control height • •
<p>2.28 If there is a LULA elevator, are the in-car controls centered on a side wall?</p>	<p><input type="checkbox"/> Yes <input type="checkbox"/> No Measurement:</p>		Photo #:	<ul style="list-style-type: none"> • Reconfigure controls • •

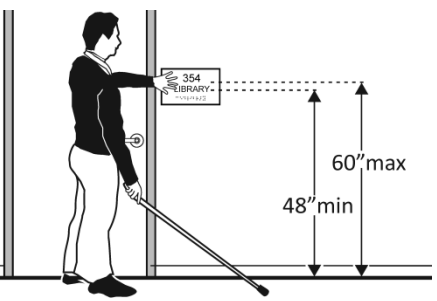
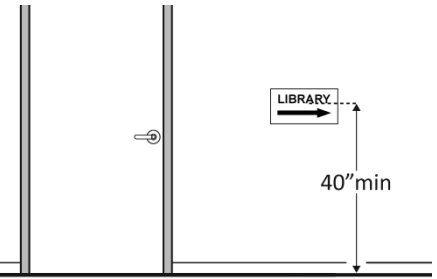
<p>2.29 If there is a full size or LULA elevator:</p> <p>Are the car control buttons designated with raised characters?</p> <p>Are the car control buttons designated with Braille?</p>	<p><input type="checkbox"/> Yes <input type="checkbox"/> No</p> <p><input type="checkbox"/> Yes <input type="checkbox"/> No</p>		<p>Photo #:</p>	<ul style="list-style-type: none"> • Add raised characters • Add Braille •
<p>2.30 If there is a full size or LULA elevator, are there audible signals which sound as the car passes or is about to stop at a floor?</p>	<p><input type="checkbox"/> Yes <input type="checkbox"/> No</p>		<p>Photo #:</p>	<ul style="list-style-type: none"> • Install audible signals • •
<p>2.31 If there is a full size or LULA elevator:</p> <p>Is there a sign on both door jambs at every floor identifying the floor?</p> <p>Is there a tactile star on both jambs at the main entry level?</p> <p>Do text characters contrast with their backgrounds?</p> <p>Are text characters raised?</p> <p>Is there Braille?</p> <p>Is the sign mounted between 48 inches to the baseline of the lowest character and 60 inches to the baseline of the highest character above the floor?*</p>	<p><input type="checkbox"/> Yes <input type="checkbox"/> No</p> <p><input type="checkbox"/> Yes <input type="checkbox"/> No</p> <p><input type="checkbox"/> Yes <input type="checkbox"/> No</p> <p><input type="checkbox"/> Yes <input type="checkbox"/> No</p> <p><input type="checkbox"/> Yes <input type="checkbox"/> No</p> <p><input type="checkbox"/> Yes <input type="checkbox"/> No</p> <p>Measurement:</p>		<p>Photo #:</p>	<ul style="list-style-type: none"> • Install signs • Change sign height • • <p>If constructed before 3/15/2012 and mounted no higher than 60 inches to the centerline of the sign, relocation is not required</p>

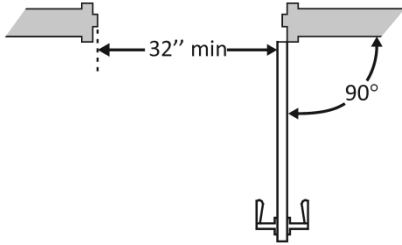
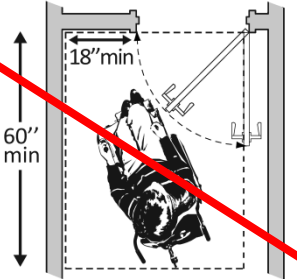
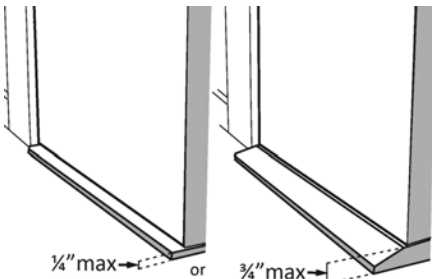
Platform Lifts (2010 Standards – 410)				
<p>2.32 If a lift is provided, can it be used without assistance from others?</p>	<p><input type="checkbox"/> Yes <input type="checkbox"/> No</p>		<p>Photo #:</p>	<ul style="list-style-type: none"> • Reconfigure so independently operable • •
<p>2.33 Is there a clear floor space at least 30 inches wide by at least 48 inches long for a person using a wheelchair to approach and reach the controls to use the lift?</p>	<p><input type="checkbox"/> Yes <input type="checkbox"/> No</p> <p>Measurement:</p>		<p>Photo #:</p>	<ul style="list-style-type: none"> • Remove obstructions • •
<p>2.34 Are the lift controls no less than 15 inches and no greater than 48 inches above the floor?</p>	<p><input type="checkbox"/> Yes <input type="checkbox"/> No</p> <p>Measurement:</p>		<p>Photo #:</p>	<ul style="list-style-type: none"> • Change control height • •
<p>2.35 Is there a clear floor space at least 30 inches wide by at least 48 inches long inside the lift?</p>	<p><input type="checkbox"/> Yes <input type="checkbox"/> No</p> <p>Measurement:</p>		<p>Photo #:</p>	<ul style="list-style-type: none"> • Replace lift • •

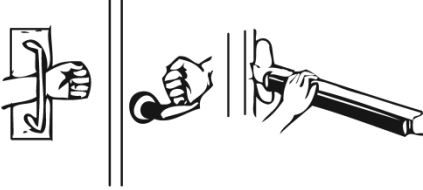
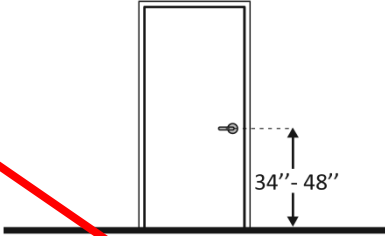

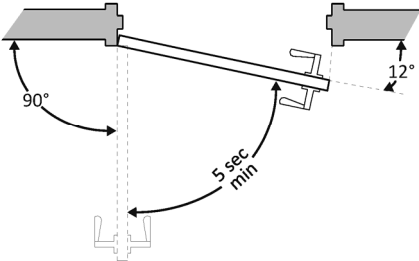
<p>2.36 If there is an end door, is the clear opening width at least 32 inches?</p>	<p><input type="checkbox"/> Yes <input type="checkbox"/> No</p> <p>Measurement:</p>		<p>Photo #:</p>	<ul style="list-style-type: none"> • Alter door width • •
<p>2.37 If there is a side door, is the clear opening width at least 42 inches?</p>	<p><input type="checkbox"/> Yes <input type="checkbox"/> No</p> <p>Measurement:</p>		<p>Photo #:</p>	<ul style="list-style-type: none"> • Alter door width • •

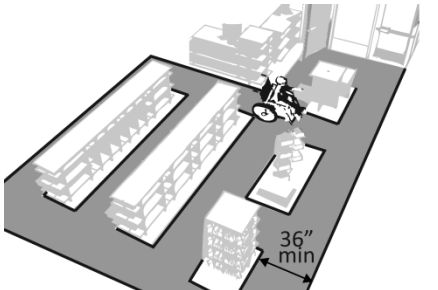

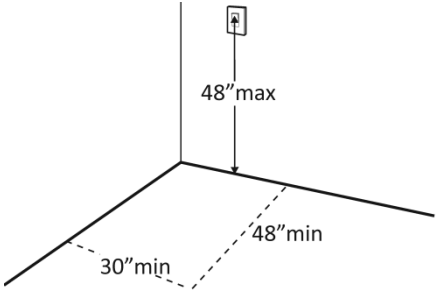
Signs (2010 Standards – 703) Note: “Tactile characters” are read using touch, i.e. raised characters and Braille.

<p>2.38 If there are signs designating permanent rooms and spaces not likely to change over time, e.g. room numbers and letters, room names, and exit signs:</p> <p>Do text characters contrast with their backgrounds? <input type="checkbox"/> Yes <input type="checkbox"/> No</p> <p>Are text characters raised? <input type="checkbox"/> Yes <input type="checkbox"/> No</p> <p>Is there Braille? <input type="checkbox"/> Yes <input type="checkbox"/> No</p> <p>Is the sign mounted: On the wall on the latch side of the door? <input type="checkbox"/> Yes <input type="checkbox"/> No</p>	<p><input type="checkbox"/> Yes <input type="checkbox"/> No</p> <p><input type="checkbox"/> Yes <input type="checkbox"/> No</p> <p><input type="checkbox"/> Yes <input type="checkbox"/> No</p> <p><input type="checkbox"/> Yes <input type="checkbox"/> No</p>		<p>Photo #:</p>	<ul style="list-style-type: none"> • Install tactile sign • Relocate sign •
---	---	---	-----------------	--

<p>Note: Signs are permitted on the push side of doors with closers and without hold-open devices.</p> <p>With clear floor space beyond the arc of the door swing between the closed position and 45-degree open position, at least 18 x 18 inches centered on the tactile characters?*</p> <p>So the baseline of the lowest character is at least 48 inches above the floor and the baseline of the highest character is no more than 60 inches above the floor? *</p> <p>Note: If the sign is at double doors with one active leaf, the sign should be on the inactive leaf; if both leaves are active, the sign should be on the wall to the right of the right leaf.</p>	<p><input type="checkbox"/> Yes <input type="checkbox"/> No</p> <p>Measurement:</p> <p><input type="checkbox"/> Yes <input type="checkbox"/> No</p> <p>Measurement:</p>		<p>Photo #:</p>	<p>*If constructed before 3/15/2010 and a person may approach within 3 inches of the sign without encountering protruding objects or standing within the door swing, relocation not required</p> <p>*If constructed before 3/15/2012 and mounted no higher than 60 inches to the centerline of the sign, relocation not required</p>
<p>2.39 If there are signs that provide direction to or information about interior spaces:</p> <p>Do text characters contrast with their backgrounds?</p> <p>Is the sign mounted so that characters are at least 40 inches above the floor?</p>	<p><input type="checkbox"/> Yes <input type="checkbox"/> No</p> <p><input type="checkbox"/> Yes <input type="checkbox"/> No</p> <p>Measurement:</p>		<p>Photo #:</p>	<ul style="list-style-type: none"> • Install signs with contrasting characters • Change sign height <p>Raised characters and Braille are not required</p>

Interior Doors – to classrooms, medical exam rooms, conference rooms, etc. (2010 Standards – 404)				
<p>2.40 Is the door opening width at least 32 inches clear, between the face of the door and the stop, when the door is open 90 degrees?</p>	<p><input type="checkbox"/> Yes <input type="checkbox"/> No</p> <p>Measurement:</p>		<p>Photo #:</p>	<ul style="list-style-type: none"> • Install offset hinges • Alter the doorway •
<p>2.41 If there is a front approach to the pull side of the door, is there at least 18 inches of maneuvering clearance beyond the latch side plus at least 60 inches clear depth?</p> <p>On both sides of the door, is the floor surface of the maneuvering clearance level (no steeper than 1:48)?</p>	<p><input type="checkbox"/> Yes <input type="checkbox"/> No</p> <p>Measurement:</p> <p><input type="checkbox"/> Yes <input type="checkbox"/> No</p> <p>Measurement:</p>		<p>Photo #:</p>	<ul style="list-style-type: none"> • Remove obstructions • Reconfigure walls • Add automatic door opener <p>See 2010 Standards 404.2.4 for maneuvering clearance requirements on the push side of the door and side approaches to the pull side of the door</p>
<p>2.42 Is the door threshold edge no more than ¼ inch high?</p> <p>Or</p> <p>No more than ¾ inch high if slope is beveled no steeper than 1:2?</p> <p>Note: The first ¼ inch of the threshold may be vertical; the rest must be beveled.</p>	<p><input type="checkbox"/> Yes <input type="checkbox"/> No</p> <p>Measurement:</p> <p><input type="checkbox"/> Yes <input type="checkbox"/> No</p> <p>Measurement:</p>		<p>Photo #:</p>	<ul style="list-style-type: none"> • Remove or replace threshold • •

<p>2.43 Is the door equipped with hardware that is operable with one hand and does not require tight grasping, pinching and twisting of the wrist?</p>	<p><input type="checkbox"/> Yes <input type="checkbox"/> No</p>		<p>Photo #:</p>	<ul style="list-style-type: none"> • Replace inaccessible knob with lever, loop or push hardware • Add automatic door opener •
<p>2.44 Are the operable parts of the hardware no less than 34 inches and no greater than 48 inches above the floor?</p>	<p><input type="checkbox"/> Yes <input type="checkbox"/> No</p> <p>Measurement:</p>		<p>Photo #:</p>	<ul style="list-style-type: none"> • Change hardware height • •
<p>2.45 Can the door be opened easily (5 pounds maximum force)?</p> <p>Note: You can use a pressure gauge or fish scale to measure force. If you do not have a pressure gauge or fish scale you will need to judge whether the door is easy to open.</p>	<p><input type="checkbox"/> Yes <input type="checkbox"/> No</p> <p>Measurement:</p>		<p>Photo #:</p>	<ul style="list-style-type: none"> • Adjust or replace closers • Install lighter doors • Install power-assisted or automatic door openers
<p>2.46 If the door has a closer, does it take at least 5 seconds to close from an open position of 90 degrees to a position of 12 degrees from the latch?</p>	<p><input type="checkbox"/> Yes <input type="checkbox"/> No</p> <p>Measurement:</p>		<p>Photo #:</p>	<ul style="list-style-type: none"> • Adjust closer • •

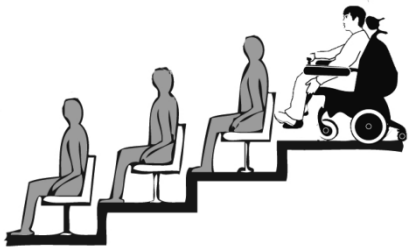
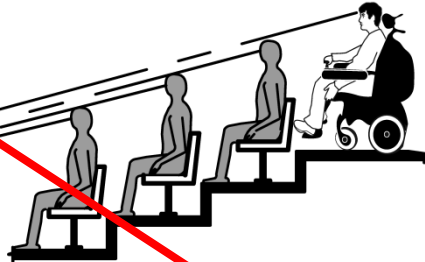
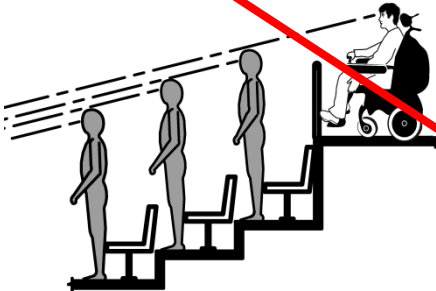

Rooms and Spaces – stores, supermarkets, libraries, etc. (2010 Standards – 302, 304, & 402)				
<p>2.47 Are aisles and pathways to goods and services, and to one of each type of sales and service counters, at least 36 inches wide?</p>	<p><input checked="" type="checkbox"/> Yes <input type="checkbox"/> No</p> <p>Measurement:</p>		<p>Photo #:</p>	<ul style="list-style-type: none"> • Rearrange goods, equipment and furniture • •
<p>2.48 Are floor surfaces stable, firm and slip resistant?</p>	<p><input checked="" type="checkbox"/> Yes <input type="checkbox"/> No</p>		<p>Photo #:</p>	<ul style="list-style-type: none"> • Change floor surface • •
<p>2.49 If there is carpet:</p> <p>Is it no higher than ½ inch?</p> <p>Is it securely attached along the edges?</p>	<p><input type="checkbox"/> Yes <input type="checkbox"/> No</p> <p>Measurement:</p> <p><input type="checkbox"/> Yes <input type="checkbox"/> No</p>		<p style="text-align: center;">NA</p> <p>Photo #:</p>	<ul style="list-style-type: none"> • Replace carpet • •
Controls – light switches, security and intercom systems, emergency/alarm boxes, etc. (2010 Standards – 309)				
<p>2.50 Is there a clear floor space at least 30 inches wide by at least 48 inches long for a forward or parallel approach?</p> <p>Are the operable parts no higher than 48 inches above the floor?*</p>	<p><input type="checkbox"/> Yes <input type="checkbox"/> No</p> <p>Measurement:</p> <p><input type="checkbox"/> Yes <input type="checkbox"/> No</p> <p>Measurement:</p>		<p style="text-align: center;">NA</p>	<ul style="list-style-type: none"> • Change height of control • • <p>*If constructed before 3/15/2012 and a parallel approach is provided, controls can be 54 inches above the floor</p>

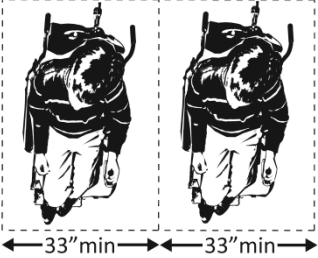
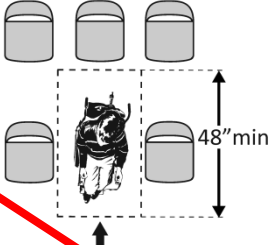
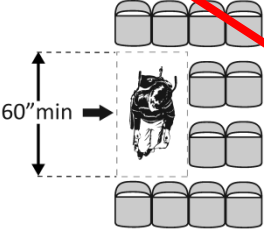
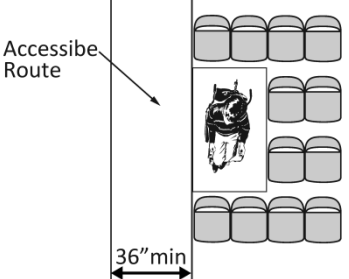
		<p>48" max 48" min 30" min</p>	Photo #:	
--	--	--	----------	--

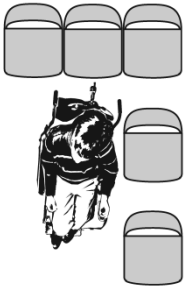

<p>2.51 Can the control be operated with one hand and without tight grasping, pinching, or twisting of the wrist?</p>	<input type="checkbox"/> Yes <input type="checkbox"/> No		Photo #:	<p>NA</p> <ul style="list-style-type: none"> • Replace control • •
--	--	--	----------	--

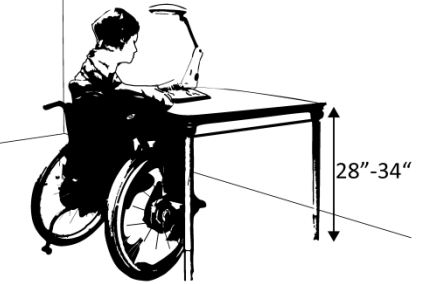
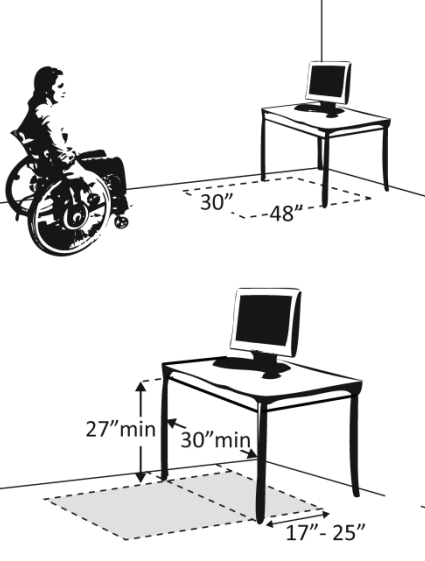
Seating: Assembly Areas – theaters, auditoriums, stadiums, theater style classrooms, etc. (2010 Standards – 221 & 802)

<p>2.52 Are an adequate number of wheelchair spaces provided?</p>	<input type="checkbox"/> Yes <input type="checkbox"/> No	<table border="1"> <thead> <tr> <th># of Seats</th> <th>Wheelchair Spaces</th> </tr> </thead> <tbody> <tr> <td>4 - 25</td> <td>1</td> </tr> <tr> <td>26 - 50</td> <td>2</td> </tr> <tr> <td>51 - 150</td> <td>4</td> </tr> <tr> <td>151 - 300</td> <td>5</td> </tr> <tr> <td colspan="2">300+ see 2010 Standards 221.2.1.</td> </tr> </tbody> </table>	# of Seats	Wheelchair Spaces	4 - 25	1	26 - 50	2	51 - 150	4	151 - 300	5	300+ see 2010 Standards 221.2.1.		Photo #:	<p>NA</p> <ul style="list-style-type: none"> • Reconfigure to add wheelchair spaces • •
# of Seats	Wheelchair Spaces															
4 - 25	1															
26 - 50	2															
51 - 150	4															
151 - 300	5															
300+ see 2010 Standards 221.2.1.																

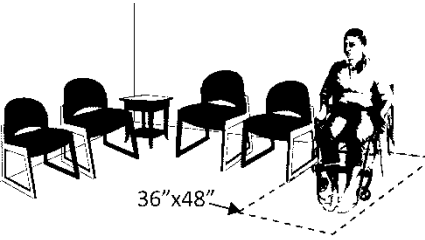
<p>2.53 Are wheelchair spaces dispersed to allow location choices and viewing angles equivalent to other seating, including specialty seating areas that provide distinct services and amenities?</p>	<p><input type="checkbox"/> Yes <input type="checkbox"/> No</p>		<p>Photo #:</p>	<ul style="list-style-type: none"> • Reconfigure to disperse wheelchair spaces • •
<p>2.54 Where people are expected to remain seated, do people in wheelchair spaces have a clear line of sight over and between the heads of others in front of them?</p>	<p><input type="checkbox"/> Yes <input type="checkbox"/> No</p>		<p>Photo #:</p>	<ul style="list-style-type: none"> • Alter for line of sight • •
<p>2.55 Where people are expected to stand, do people in wheelchair spaces have a clear line of sight over and between the heads of others in front of them?</p>	<p><input type="checkbox"/> Yes <input type="checkbox"/> No</p>		<p>Photo #:</p>	<ul style="list-style-type: none"> • Alter for line of sight • •
<p>2.56 If there is a single wheelchair space, is it at least 36 inches wide?</p>	<p><input type="checkbox"/> Yes <input type="checkbox"/> No</p> <p>Measurement:</p>		<p>Photo #:</p>	<ul style="list-style-type: none"> • Alter space • •

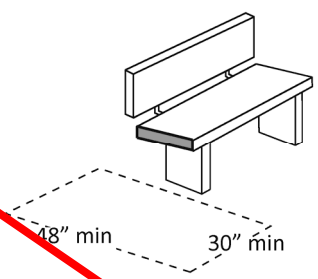
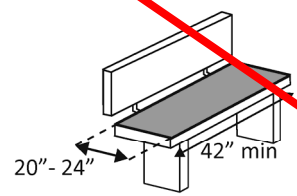
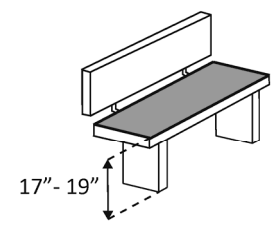
<p>2.57 If there are two adjacent wheelchair spaces, are they each at least 33 inches wide?</p>	<p><input type="checkbox"/> Yes <input type="checkbox"/> No</p> <p>Measurement:</p>		<p>Photo #:</p>	<ul style="list-style-type: none"> • Alter spaces • •
<p>2.58 If the wheelchair space can be entered from the front or rear, is it at least 48 inches deep?</p>	<p><input type="checkbox"/> Yes <input type="checkbox"/> No</p> <p>Measurement:</p>		<p>Photo #:</p>	<ul style="list-style-type: none"> • Alter space • •
<p>2.59 If the wheelchair space can only be entered from the side, is it at least 60 inches deep?</p>	<p><input type="checkbox"/> Yes <input type="checkbox"/> No</p> <p>Measurement:</p>		<p>Photo #:</p>	<ul style="list-style-type: none"> • Alter space • •
<p>2.60 Do wheelchair spaces adjoin, but not overlap, accessible routes?</p>	<p><input type="checkbox"/> Yes <input type="checkbox"/> No</p>		<p>Photo #:</p>	<ul style="list-style-type: none"> • Alter spaces • •

<p>2.61 Is there at least one companion seat for each wheelchair space?</p>	<p><input type="checkbox"/> Yes <input type="checkbox"/> No</p>		<p>Photo #:</p>	<ul style="list-style-type: none"> • Add companion seats • •
<p>2.62 Is the companion seat located so the companion is shoulder-to-shoulder with the person in a wheelchair?</p>	<p><input type="checkbox"/> Yes <input type="checkbox"/> No</p>		<p>Photo #:</p>	<ul style="list-style-type: none"> • Alter seating • •
<p>2.63 Is the companion seat equivalent in size, quality, comfort and amenities to seating in the immediate area?</p>	<p><input type="checkbox"/> Yes <input type="checkbox"/> No</p>		<p>Photo #:</p>	<ul style="list-style-type: none"> • Add equivalent seating • •
<p>Seating: At dining surfaces (restaurants, cafeterias, bars, etc.) and non-employee work surfaces (libraries, conference rooms, etc.) (2010 Standards – 226 & 902)</p>				
<p>2.64 Are at least 5%, but no fewer than one, of seating and standing spaces accessible for people who use wheelchairs?</p>	<p><input type="checkbox"/> Yes <input type="checkbox"/> No</p> <p>Total #:</p> <p>Wheelchair #:</p>		<p>Photo #:</p>	<ul style="list-style-type: none"> • Alter to provide accessible spaces • •
<p>2.65 Is there a route at least 36 inches wide to accessible seating?</p>	<p><input type="checkbox"/> Yes <input type="checkbox"/> No</p> <p>Measurement:</p>		<p>Photo #:</p>	<ul style="list-style-type: none"> • Widen route • •

<p>2.66 At the accessible space(s), is the top of the accessible surface no less than 28 inches and no greater than 34 inches above the floor?</p>	<p><input type="checkbox"/> Yes <input type="checkbox"/> No</p> <p>Measurement:</p>		<p style="text-align: center;">NA</p> <p>Photo #:</p>	<ul style="list-style-type: none"> • Alter surface height • •
<p>2.67 Is there a clear floor space at least 30 inches wide by at least 48 inches long for a forward approach?</p> <p>Does it extend no less than 17 inches and no greater than 25 inches under the surface?</p> <p>Is there knee space at least 27 inches high and at least 30 inches wide?</p>	<p><input type="checkbox"/> Yes <input type="checkbox"/> No</p> <p>Measurement:</p> <p><input type="checkbox"/> Yes <input type="checkbox"/> No</p> <p>Measurement:</p> <p><input type="checkbox"/> Yes <input type="checkbox"/> No</p> <p>Measurement:</p>		<p style="text-align: center;">NA</p> <p>Photo #:</p>	<ul style="list-style-type: none"> • Alter table or work surface • Add accessible table or work surface •

Seating: General – reception areas, waiting rooms, etc. (2010 Standards – 801)

<p>2.68 Is there at least one space at least 36 inches wide by at least 48 inches long for a person in a wheelchair?</p>	<p><input checked="" type="checkbox"/> Yes <input type="checkbox"/> No</p> <p>Measurement:</p>		<p style="text-align: center;">No seating provided</p> <p>Photo #:</p>	<ul style="list-style-type: none"> • Move furniture and equipment to provide space • •
---	--	--	---	---

Benches – In locker rooms, dressing rooms, fitting rooms (2010 Standards – 803 & 903)				
<p>2.69 In locker rooms, dressing rooms and fitting rooms, is there at least one room with a bench?</p>	<p><input type="checkbox"/> Yes <input type="checkbox"/> No</p>		<p>Photo #:</p>	<ul style="list-style-type: none"> • Add bench • •
<p>2.70 Is there a clear floor space at least 30 inches wide by at least 48 inches long at the end of the bench and parallel to the short axis of the bench?</p> <p>Is the bench seat at least 42 inches long and no less than 20 inches and no greater than 24 inches deep?</p> <p>Does the bench have back support or is it affixed to a wall?</p> <p>Is the top of the bench seat no less than 17 inches and no greater than 19 inches above the floor?</p>	<p><input type="checkbox"/> Yes <input type="checkbox"/> No</p> <p>Measurement:</p> <p><input type="checkbox"/> Yes <input type="checkbox"/> No</p> <p>Measurement:</p> <p><input type="checkbox"/> Yes <input type="checkbox"/> No</p> <p>Measurement:</p> <p><input type="checkbox"/> Yes <input type="checkbox"/> No</p> <p>Measurement:</p>	  	<p>Photo #:</p>	<ul style="list-style-type: none"> • Move bench • Replace bench • Affix bench to wall • •

Check-Out Aisles – supermarkets, large retail stores, etc. (2010 Standards – 904)

2.71 Is the aisle at least 36 inches wide?

Yes No

Measurement:

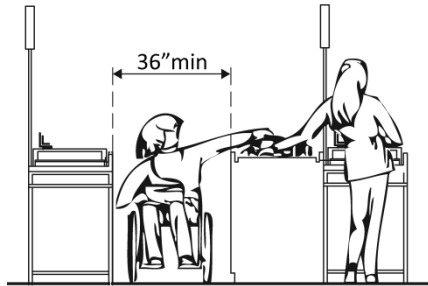


Photo #:

- Widen aisle
-
-

2.72 Is the counter surface of at least one aisle no higher than 38 inches above the floor?

Yes No

Measurement:

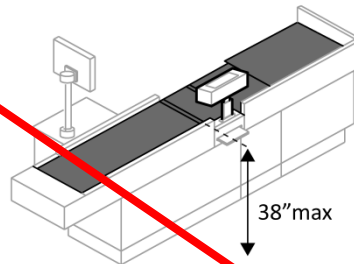


Photo #:

- Lower counter
-
-

2.73 Is the top of the counter edge protection no higher than 2 inches above the counter surface?

Yes No

Measurement:

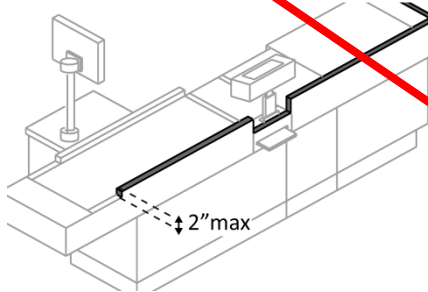


Photo #:

- Lower edge protection
-
-

2.74 If there is a check writing surface, is the top no less than 28 inches and no greater than 34 inches above the floor?

Yes No

Measurement:

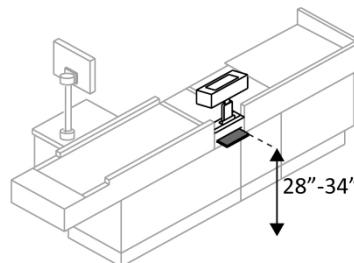

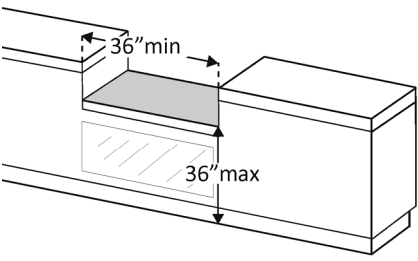
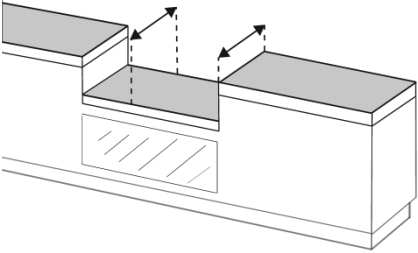
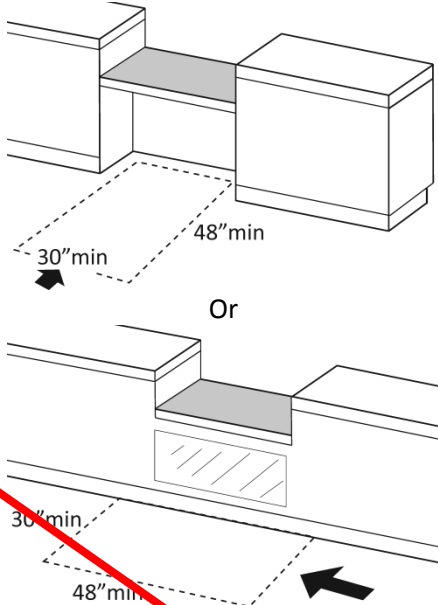
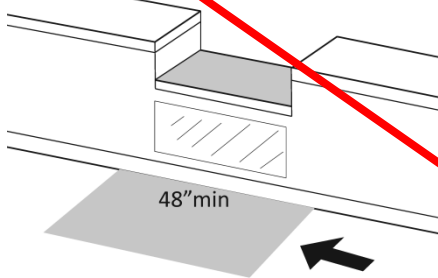
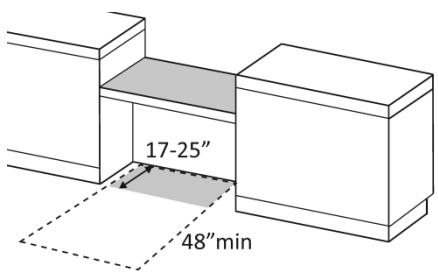
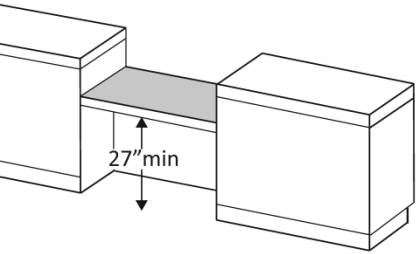
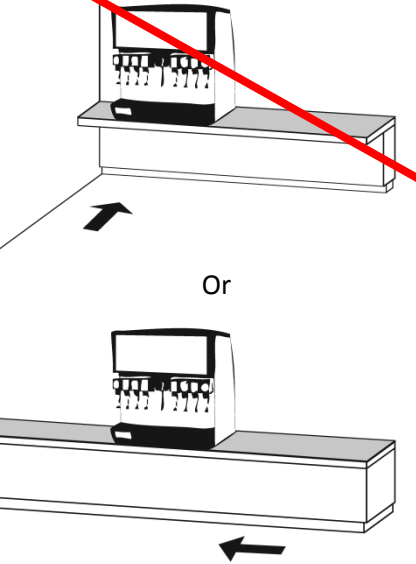


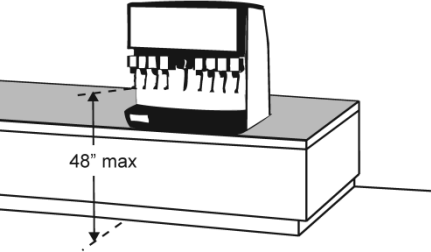
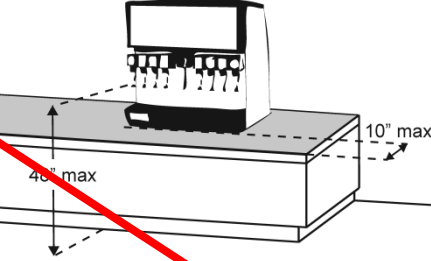
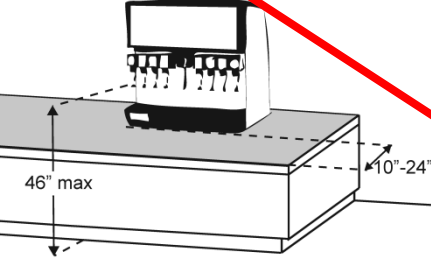
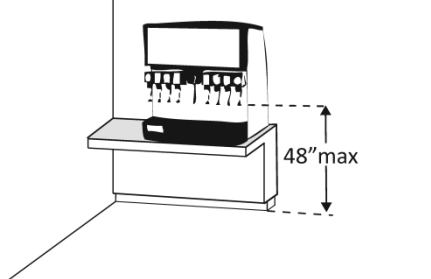
Photo #:

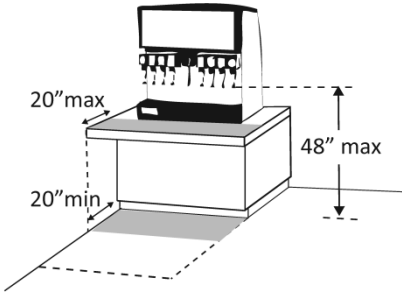
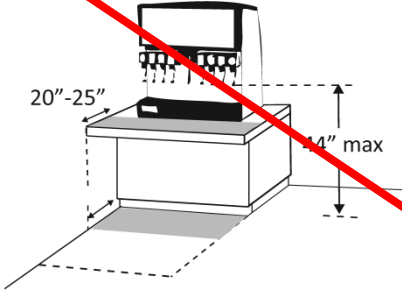
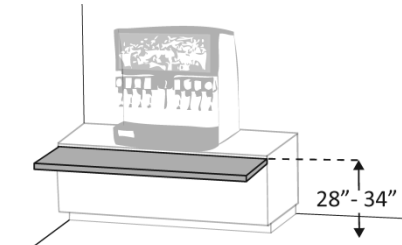
- Alter check writing surface
-
-

<p>2.75 If there is more than one check-out aisle is there a sign with the International Symbol of Accessibility at the accessible aisle?</p>	<p><input type="checkbox"/> Yes <input type="checkbox"/> No</p>		<p style="text-align: center;">NA</p> <p>Photo #:</p>	<ul style="list-style-type: none"> • Add sign • •
<p>Sales & Service Counters – banks, stores, dry cleaners, auto repair shops, fitness clubs, etc. (2010 Standards – 904)</p>				
<p>2.76 Is there a portion of at least one of each type of counter that is: No higher than 36 inches above the floor? At least 36 inches long?</p>	<p><input type="checkbox"/> Yes <input checked="" type="checkbox"/> No Measurement: 42"</p> <p><input checked="" type="checkbox"/> Yes <input type="checkbox"/> No Measurement: 84"</p>		<p>Photo #: 2.76</p>	<ul style="list-style-type: none"> • Lower section of counter • Lengthen section of counter •
<p>2.77 Does the accessible portion of the counter extend the same depth as the counter top?</p>	<p><input type="checkbox"/> Yes <input type="checkbox"/> No Measurement:</p>		<p style="text-align: center;">NA</p> <p>Photo #:</p>	<ul style="list-style-type: none"> • Alter accessible portion • •

<p>2.78 Is there a clear floor space at least 30 inches wide by at least 48 inches long for a forward or parallel approach?</p>	<p><input type="checkbox"/> Yes <input type="checkbox"/> No</p> <p><input type="checkbox"/> Parallel Measurement:</p> <p><input type="checkbox"/> Forward Measurement:</p>		<p>Photo #:</p>	<ul style="list-style-type: none"> • Reconfigure to provide a parallel or forward approach • •
<p>2.79 For a parallel approach, is the clear floor space positioned with the 48 inches adjacent to the accessible length of counter?</p>	<p><input type="checkbox"/> Yes <input type="checkbox"/> No</p> <p>Measurement:</p>		<p>Photo #:</p>	<ul style="list-style-type: none"> • If a parallel approach is not possible, a forward approach is required • •
<p>2.80 For a forward approach:</p> <p>Do no less than 17 and no greater than 25 inches of the clear floor space extend under the accessible length of the counter?</p> <p>Is there at least 27 inches clearance from the floor to the</p>	<p><input type="checkbox"/> Yes <input type="checkbox"/> No</p> <p>Measurement:</p> <p><input type="checkbox"/> Yes <input type="checkbox"/> No</p>		<p>Photo #:</p>	<ul style="list-style-type: none"> • Reconfigure to provide knee clearance • •

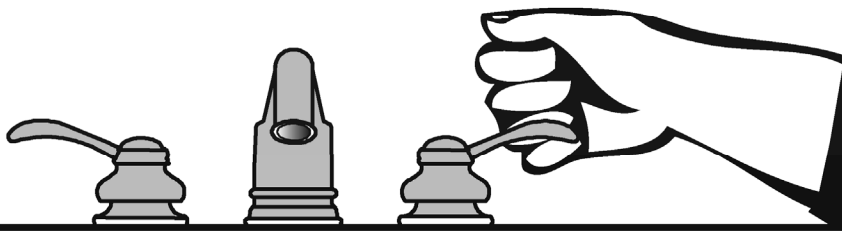
<p>bottom of the counter?</p>	<p>Measurement:</p>		<p>Photo #:</p>	
<p>Food Service Lines – in cafeterias, salad bars, eat-in fast food establishments, etc. (2010 Standards – 904)</p>				
<p>2.81 Does at least one of each type of self-service shelf or dispensing device for tableware, dishware, condiments, food and beverages have a forward or parallel approach?</p>	<p><input type="checkbox"/> Yes <input type="checkbox"/> No</p> <p><input type="checkbox"/> Forward</p> <p><input type="checkbox"/> Parallel</p>		<p>Photo #:</p>	<ul style="list-style-type: none"> • Reconfigure to provide approach • •

<p>2.82 If there is an unobstructed parallel approach, is the shelf or dispensing device no higher than 48 inches above the floor?</p>	<p><input type="checkbox"/> Yes <input type="checkbox"/> No</p> <p>Measurement:</p>		<p>Photo #:</p>	<ul style="list-style-type: none"> • Lower shelf and/or dispensing device • •
<p>2.83 If there is a shallow obstruction no deeper than 10 inches with a parallel approach, is the shelf or dispensing device no higher than 48 inches above the floor?</p>	<p><input type="checkbox"/> Yes <input type="checkbox"/> No</p> <p>Measurement:</p>		<p>Photo #:</p>	<ul style="list-style-type: none"> • Lower shelf and/or dispensing device • •
<p>2.84 If there is an obstruction no less than 10 inches and no greater than 24 inches deep with a parallel approach, is the shelf or dispensing device no higher than 46 inches above the floor?</p>	<p><input type="checkbox"/> Yes <input type="checkbox"/> No</p> <p>Measurement:</p>		<p>Photo #:</p>	<ul style="list-style-type: none"> • Lower shelf and/or dispensing device • •
<p>2.85 If there is an unobstructed forward approach, is the shelf or dispensing device no higher than 48 inches above the floor?</p>	<p><input type="checkbox"/> Yes <input type="checkbox"/> No</p> <p>Measurement:</p>		<p>Photo #:</p>	<ul style="list-style-type: none"> • Lower shelf and/or dispensing device • •

<p>2.86 If there is an obstruction no deeper than 20 inches with a forward approach:</p> <p>Does clear floor space extend under the obstruction that is at least the same depth as the obstruction?</p> <p>Is the shelf or dispensing device no higher than 48 inches above the floor?</p>	<p><input type="checkbox"/> Yes <input type="checkbox"/> No Measurement:</p> <p><input type="checkbox"/> Yes <input type="checkbox"/> No Measurement:</p>		<p>Photo #:</p>	<ul style="list-style-type: none"> • Reconfigure to provide knee space • Lower shelf and/or dispensing device •
<p>2.87 If the obstruction is no less than 20 inches and no greater than 25 inches deep with a forward approach:</p> <p>Does clear floor space extend under the obstruction that is at least the same depth as the obstruction?</p> <p>Is the shelf or dispensing device no higher than 44 inches above the floor?</p>	<p><input type="checkbox"/> Yes <input type="checkbox"/> No Measurement:</p> <p><input type="checkbox"/> Yes <input type="checkbox"/> No Measurement:</p>		<p>Photo #:</p>	<ul style="list-style-type: none"> • Reconfigure to provide knee space • Lower shelf and/or dispensing device •
<p>2.88 If there is a tray slide, is the top no less than 28 inches and no greater than 34 inches above the floor?</p>	<p><input type="checkbox"/> Yes <input type="checkbox"/> No Measurement:</p>		<p>Photo #:</p>	<ul style="list-style-type: none"> • Reconfigure • •

The ADA Checklist for Readily Achievable Barrier Removal

Priority 3 – Toilet Room



Project **SDDOT Rest Area Improvements**
FHU Reference Number 13-039-01
TSP Project Number 03120855

Building **VALLEY SPRINGS POE**

Location **90 W., MRM 412**

Date **09-18-2013 (Inspection)**

Surveyors **Timothy Roach, AIA**
Todd Schultz, PE

Robert King , CPD

Contact Information **TSP – (605) 343-6102**

When toilet rooms are open to the public they should be accessible to people with disabilities.





Institute for Human Centered Design
www.HumanCenteredDesign.org

November 2011



ADA National Network
Questions on the ADA 800-949-4232 voice/tty
www.ADAchecklist.org

Priority 3 – Toilet Rooms		Comments	Possible Solutions
<p>3.1 If toilet rooms are available to the public, is at least one toilet room accessible? (Either one for each sex, or one unisex.)</p> <p><input type="checkbox"/> Yes <input checked="" type="checkbox"/> No</p>		<p>NOT AVAILABLE TO PUBLIC 2' 10" DOOR TO ROOM,</p> <p>Photo #: 3.1</p>	<ul style="list-style-type: none"> • Reconfigure toilet rooms • Combine toilet rooms to create one unisex accessible toilet room
<p>3.2 Are there signs at inaccessible toilet rooms that give directions to accessible toilet rooms?</p> <p><input type="checkbox"/> Yes <input checked="" type="checkbox"/> No</p>		<p>Photo #:</p>	<ul style="list-style-type: none"> • Install signs
<p>3.3 If not all toilet rooms are accessible, is there a sign at the accessible toilet room with the International Symbol of Accessibility?</p> <p><input type="checkbox"/> Yes <input type="checkbox"/> No</p>		<p>Photo #: NA</p>	<ul style="list-style-type: none"> • Install sign
<p>Accessible Route (2010 Standards – Chapter 4)</p>			
<p>3.4 Is there a route to the accessible toilet room(s) that does not include the use of stairs?</p> <p><input checked="" type="checkbox"/> Yes <input type="checkbox"/> No</p>		<p>Route to Restroom blocked – 48" x 48" clearance required at entrance – counter blocks this space</p> <p>Photo #:</p>	<ul style="list-style-type: none"> • Alter route
<p>Is the route accessible? (See Priority 2 Interior Accessible Route for specifics.)</p> <p><input type="checkbox"/> Yes <input checked="" type="checkbox"/> No</p>			

Signs at Toilet Rooms (2010 Standards – 703)

3.5 Do text characters contrast with their backgrounds?

Yes No

Are text characters raised?

Yes No

Is there Braille?

Yes No

Is the sign mounted:
On the wall on the latch side of the door?

Yes No

Note:

Signs are permitted on the push side of doors with closers and without hold-open devices.

With clear floor space beyond the arc of the door swing and 45-degree open position, at least 18 x 18 inches centered on the tactile characters? *

Yes No

Measurement:

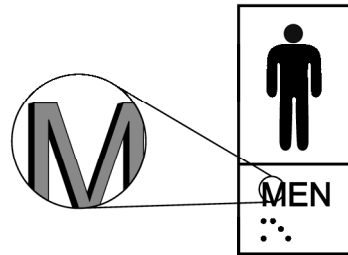
So the baseline of the lowest character is at least 48 inches above the floor and the baseline of the highest character is no more than 60 inches above the floor? *

Yes No

Measurement:

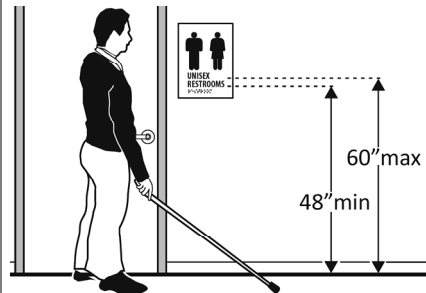
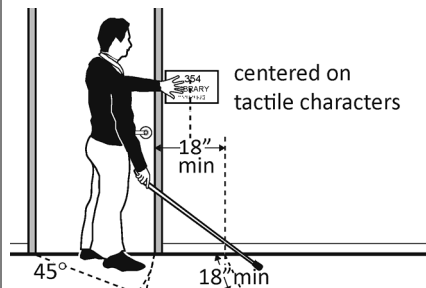
Note:

If the sign is at double doors with one active leaf, the sign should be on the inactive leaf; if both leaves are active, the sign



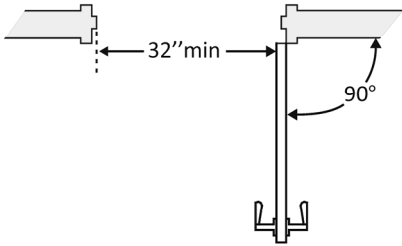
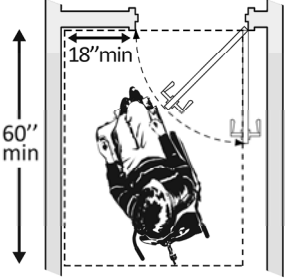
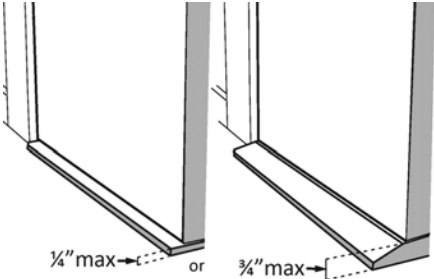
No signs provided.

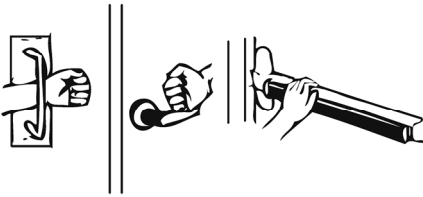
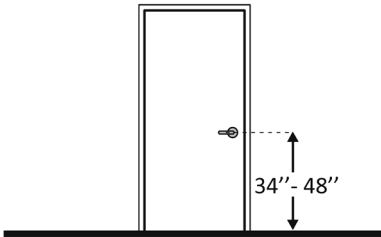

- Install tactile sign
- Relocate sign
-

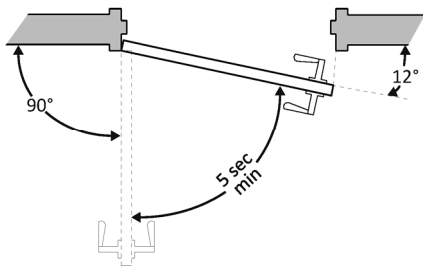
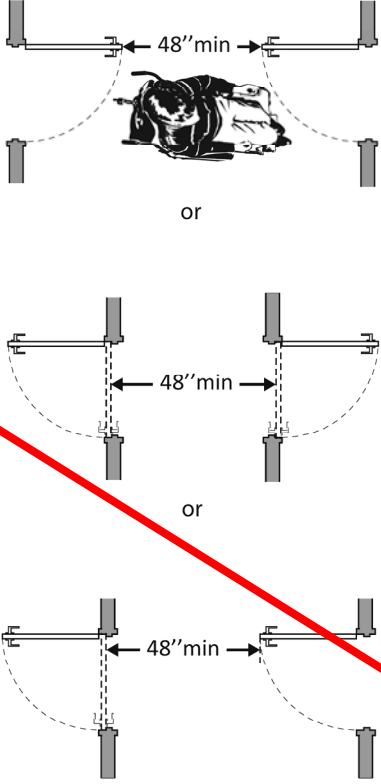


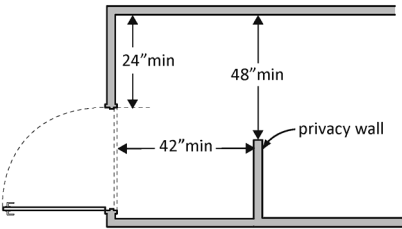
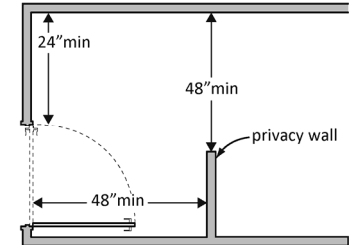

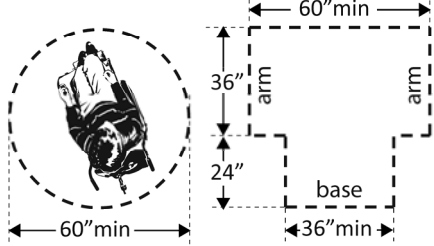
*If constructed before 3/15/2010 and a person may approach within 3 inches of the sign without encountering protruding objects or standing within the door swing, relocation not required

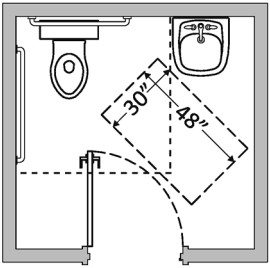
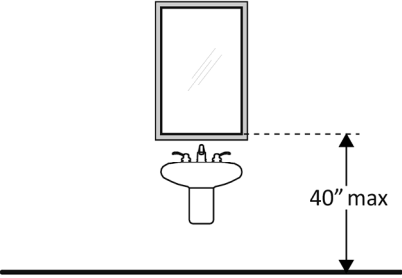
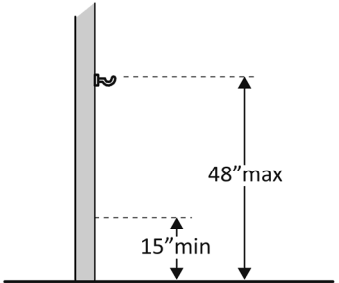
*If constructed before 3/15/2012 and mounted no higher than 60 inches to the centerline of the sign, relocation is not required

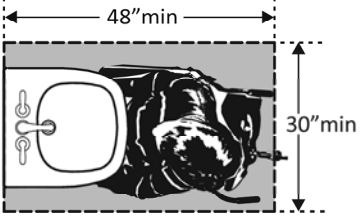
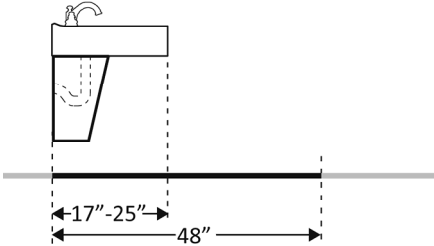
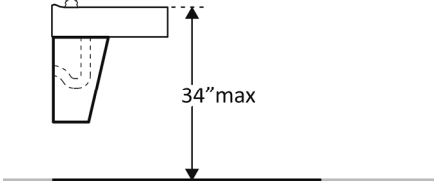
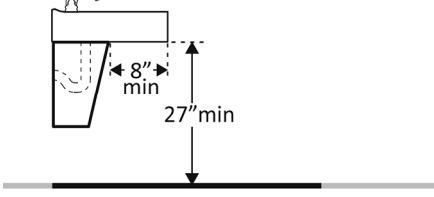
<p>should be on the wall to the right of the right leaf.</p>			<p>Photo #:</p>	
<p>Entrance (2010 Standards – 404)</p>				
<p>3.6 Is the door opening width at least 32 inches clear, between the face of the door and the stop, when the door is open 90 degrees?</p>	<p><input type="checkbox"/> Yes <input checked="" type="checkbox"/> No</p> <p>Measurement:</p>		<p>2"-10" door</p> <p>Photo #:</p>	<ul style="list-style-type: none"> • Install offset hinges • Alter the doorway •
<p>3.7 If there is a front approach to the pull side of the door is there at least 18 inches of maneuvering clearance beyond the latch side plus 60 inches clear depth?</p> <p>On both sides of the door, is the floor surface of the maneuvering clearance level (no steeper than 1:48)?</p>	<p><input checked="" type="checkbox"/> Yes <input type="checkbox"/> No</p> <p>Measurement: 24"</p> <p><input checked="" type="checkbox"/> Yes <input type="checkbox"/> No</p> <p>Measurement:</p>		<p>Photo #: 3.7</p>	<ul style="list-style-type: none"> • Remove obstructions • Reconfigure walls • Add automatic door opener <p>See 2010 Standards 404.2.4 for maneuvering clearance requirements on the push side of the door and side approaches to the pull side of the door</p>
<p>3.8 Is the door threshold edge no more than ¼ inch high?</p> <p>Or</p> <p>No more than ¾ inch high if slope is beveled no steeper than 1:2?</p> <p>Note: The first ¼ inch of the threshold may be vertical; the</p>	<p><input type="checkbox"/> Yes <input type="checkbox"/> No</p> <p>Measurement:</p> <p><input type="checkbox"/> Yes <input type="checkbox"/> No</p> <p>Measurement:</p>		<p>NA – NO THRESHOLD</p>	<ul style="list-style-type: none"> • Remove or replace threshold • •

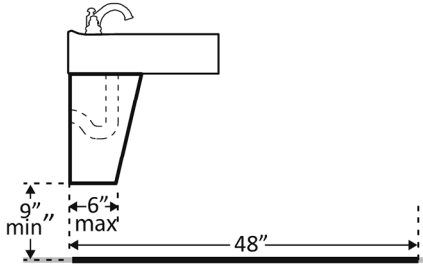
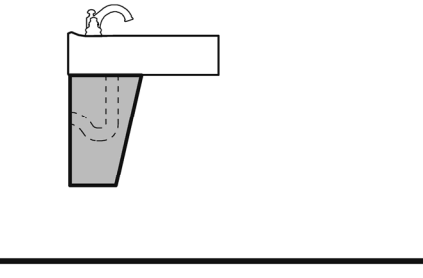
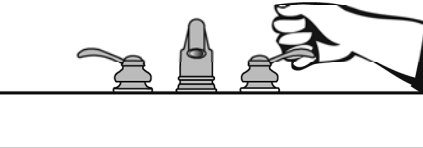
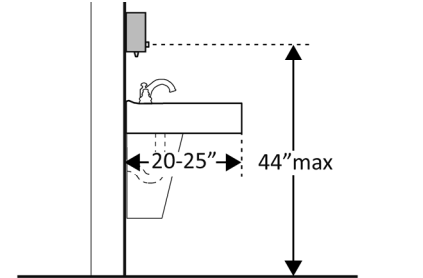
<p>rest must be beveled.</p>			<p>Photo #:</p>	
<p>3.9 Is the door equipped with hardware that is operable with one hand and does not require tight grasping, pinching, or twisting of the wrist? Check door handle and lock (if provided).</p>	<p><input type="checkbox"/> Yes <input checked="" type="checkbox"/> No</p> <p>Measurement:</p>		<p>Photo #: 3.9 (sim.)</p>	<ul style="list-style-type: none"> • Replace knobs or latches with lever or loop handles • Install power-assisted or automatic door openers •
<p>3.10 Are the operable parts of the door hardware mounted no less than 34 inches and no greater than 48 inches above the floor?</p>	<p><input checked="" type="checkbox"/> Yes <input type="checkbox"/> No</p> <p>Measurement:</p> <p>36"</p>		<p>Photo #:</p>	<ul style="list-style-type: none"> • Change hardware height • •
<p>3.11 Can the door be opened easily (5 pounds maximum force)?</p>	<p><input checked="" type="checkbox"/> Yes <input type="checkbox"/> No</p> <p>Measurement:</p>		<p>NO CLOSER</p> <p>Photo #:</p>	<ul style="list-style-type: none"> • Adjust or replace closers • Install lighter doors • Install power-assisted or automatic door openers

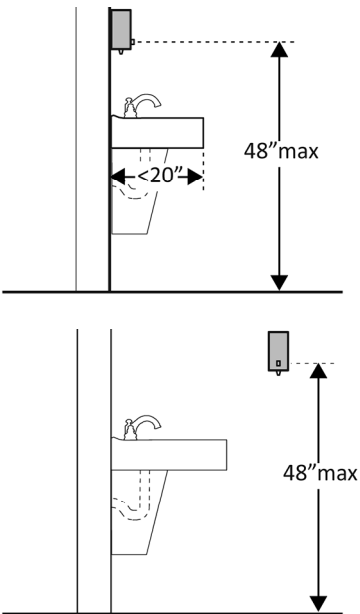
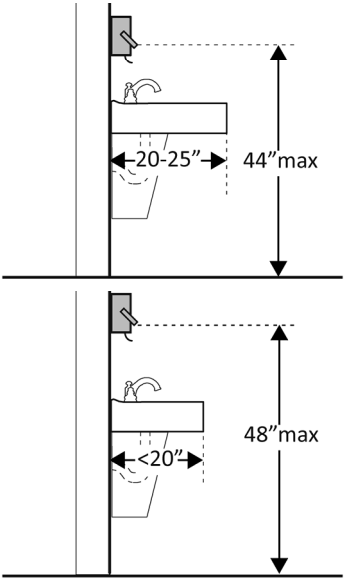
<p>3.12 If the door has a closer, does it take at least 5 seconds to close from an open position of 90 degrees to a position of 12 degrees from the latch?</p>	<p><input type="checkbox"/> Yes <input type="checkbox"/> No</p> <p>Measurement:</p>		<p>NA - NO CLOSER</p> <p>Photo #:</p>	<ul style="list-style-type: none"> • Adjust closer • •
<p>3.13 If there are two doors in a series, e.g. vestibule, is the distance between the doors at least 48 inches plus the width of the doors when swinging into the space?</p>	<p><input type="checkbox"/> Yes <input type="checkbox"/> No</p> <p>Measurement:</p>		<p>Photo #:</p>	<ul style="list-style-type: none"> • Remove inner door • Change door swing •

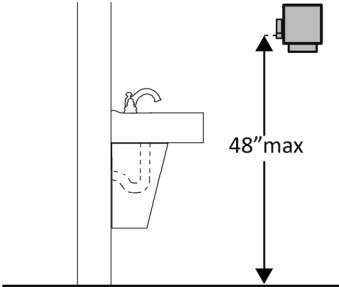
<p>3.14 If there is a privacy wall and the door swings out, is there at least 24 inches of maneuvering clearance beyond the door latch side and 42 inches to the privacy wall?</p>	<p><input type="checkbox"/> Yes <input type="checkbox"/> No</p> <p>Measurement:</p>		<p>Photo #:</p>	<ul style="list-style-type: none"> • Reconfigure space • •
<p>3.15 If there is a privacy wall and the door swings in, is there at least 24 inches of maneuvering clearance beyond the door latch side and at least 48 inches to the privacy wall if there is no door closer or at least 54 inches if there is a door closer?</p>	<p><input type="checkbox"/> Yes <input type="checkbox"/> No</p> <p>Measurement:</p>		<p>Photo #:</p>	<ul style="list-style-type: none"> • Reconfigure space • •
<p>In the Toilet Room</p>				
<p>3.16 Is there a clear path to at least one of each type of fixture, e.g. lavatory, hand dryer, etc., that is at least 36 inches wide?</p>	<p><input checked="" type="checkbox"/> Yes <input type="checkbox"/> No</p> <p>Measurement:</p>		<p>Photo #: 3.16</p>	<ul style="list-style-type: none"> • Remove obstructions • •
<p>3.17 Is there clear floor space available for a person in a wheelchair to turn around, i.e. a circle at least 60 inches in diameter or a T-shaped space within a 60-inch square?*</p>	<p><input checked="" type="checkbox"/> Yes <input type="checkbox"/> No</p> <p>Measurement:</p>		<p>Photo #: 3.1</p>	<ul style="list-style-type: none"> *The door to the toilet room may swing into the required turning space • Move or remove partitions, fixtures or objects such as trash cans

<p>3.18 In a single user toilet room if the door swings in and over a clear floor space at an accessible fixture, is there a clear floor space at least 30 x 48 inches beyond the swing of the door?</p>	<p><input checked="" type="checkbox"/> Yes <input type="checkbox"/> No Measurement:</p>		<p>Photo #: 3.1</p>	<ul style="list-style-type: none"> • Reverse door swing • Alter toilet room •
<p>3.19 If the mirror is over a lavatory or countertop, is the bottom edge of the reflecting surface no higher than 40 inches above the floor? Or If the mirror is not over the lavatory or countertop, is the bottom edge of the reflecting surface no higher than 35 inches above the floor?*</p>	<p><input checked="" type="checkbox"/> Yes <input type="checkbox"/> No Measurement: 40" <input type="checkbox"/> Yes <input type="checkbox"/> No Measurement: NA</p>		<p>Photo #: 3.16</p>	<p>* If installed before 3/15/2012 and the bottom edge of the reflecting surface is no higher than 40 inches above the floor, lowering the mirror to 35 inches is not required</p> <ul style="list-style-type: none"> • Lower the mirror • Add another mirror •
<p>3.20 If there is a coat hook, is it no less than 15 inches and no greater than 48 inches above the floor?</p>	<p><input type="checkbox"/> Yes <input type="checkbox"/> No Measurement: NA</p>		<p>Photo #:</p>	<ul style="list-style-type: none"> • Adjust hook • Replace with or provide additional accessible hook •

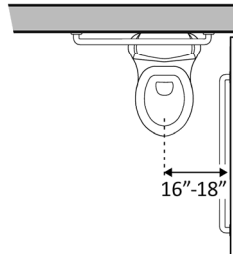
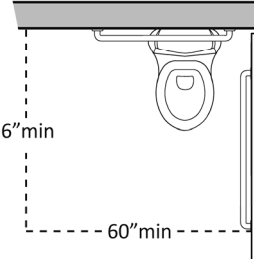
Lavatories (2010 Standards – 606) Note: 2010 Standards refer to sinks in toilet rooms as lavatories.				
<p>3.21 Does at least one lavatory have a clear floor space for a forward approach at least 30 inches wide and 48 inches long?</p>	<p><input checked="" type="checkbox"/> Yes <input type="checkbox"/> No</p> <p>Measurement:</p>		<p>Photo #: 3.21</p>	<ul style="list-style-type: none"> • Alter lavatory • Replace lavatory •
<p>3.22 Do no less than 17 inches and no greater than 25 inches of the clear floor space extend under the lavatory so that a person using a wheelchair can get close enough to reach the faucet?</p>	<p><input checked="" type="checkbox"/> Yes <input type="checkbox"/> No</p> <p>Measurement:</p> <p>18"</p>		<p>Photo #: 3.21</p>	<ul style="list-style-type: none"> • Alter lavatory • Replace lavatory •
<p>3.23 Is the front of the lavatory or counter surface, whichever is higher, no more than 34 inches above the floor?</p>	<p><input checked="" type="checkbox"/> Yes <input type="checkbox"/> No</p> <p>Measurement:</p> <p>32"</p>		<p>Photo #: 3.21</p>	<ul style="list-style-type: none"> • Alter lavatory • Replace lavatory •
<p>3.24 Is there at least 27 inches clearance from the floor to the bottom of the lavatory that extends at least 8 inches under the lav for knee clearance?</p>	<p><input checked="" type="checkbox"/> Yes <input type="checkbox"/> No</p> <p>Measurement:</p> <p>28"</p>		<p>Photo #: 3.21</p>	<ul style="list-style-type: none"> • Alter lavatory • Replace lavatory •

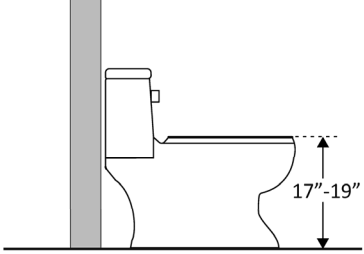
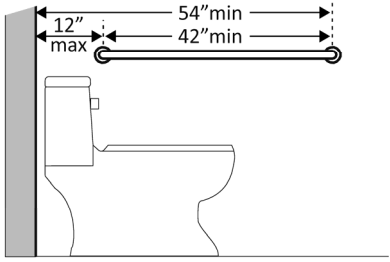
<p>3.25 Is there toe clearance at least 9 inches high? (Space extending greater than 6 inches beyond the available toe clearance at 9 inches above the floor is not considered toe clearance.)</p>	<p><input checked="" type="checkbox"/> Yes <input type="checkbox"/> No</p>		<p>Photo #: 3.21</p>	<ul style="list-style-type: none"> • Alter lavatory • Replace lavatory •
<p>3.26 Are pipes below the lavatory insulated or otherwise configured to protect against contact?</p>	<p><input type="checkbox"/> Yes <input checked="" type="checkbox"/> No</p>		<p>Photo #: 3.21</p>	<ul style="list-style-type: none"> • Install insulation • Install cover panel •
<p>3.27 Can the faucet be operated without tight grasping, pinching, or twisting of the wrist? Is the force required to activate the faucet no greater than 5 pounds?</p>	<p><input type="checkbox"/> Yes <input checked="" type="checkbox"/> No</p> <p><input type="checkbox"/> Yes <input type="checkbox"/> No</p>		<p>Photo #: 3.21</p>	<ul style="list-style-type: none"> • Adjust faucet • Replace faucet •
<p>Soap Dispensers and Hand Dryers (2010 Standards – 603)</p>				
<p>3.28 Are the operable parts of the soap dispenser within one of the following reach ranges: Above lavatories or counters no less than 20 inches and no greater than 25 inches deep; no higher than 44 inches above the</p>	<p><input type="checkbox"/> Yes <input type="checkbox"/> No</p> <p>Measurement:</p>		<p>NA- NO SOAP DISPENSER</p>	<ul style="list-style-type: none"> • Adjust dispensers • Replace with or provide additional accessible dispensers •

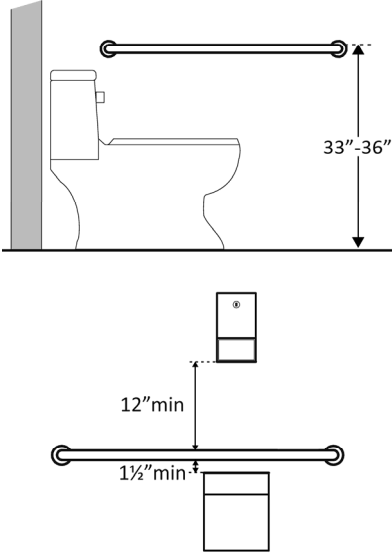
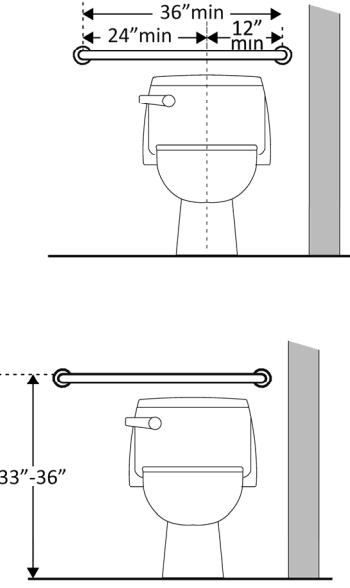
<p>floor?</p> <p>Above lavatories less than 20 inches deep: no higher than 48 inches above the floor?</p> <p>Not over an obstruction: no higher than 48 inches above the floor?</p>	<p><input type="checkbox"/> Yes <input type="checkbox"/> No</p> <p>Measurement:</p> <p><input type="checkbox"/> Yes <input type="checkbox"/> No</p> <p>Measurement:</p>		<p>NA – NO SOAP DISPENSER</p> <p>Photo #:</p>	
<p>3.29 Are the operable parts of the hand dryer or towel dispenser within one of the following reach ranges:</p> <p>Above lavatories or counters no less than 20 inches and no greater than 25 inches deep: no higher than 44 inches above the floor?</p> <p>Above lavatories less than 20 inches deep: no higher than 48 inches above the floor?</p> <p>Not over an obstruction: no higher than 48 inches above the floor?</p>	<p><input type="checkbox"/> Yes <input checked="" type="checkbox"/> No</p> <p>Measurement: 52"</p> <p><input type="checkbox"/> Yes <input type="checkbox"/> No</p> <p>Measurement:</p> <p><input type="checkbox"/> Yes <input type="checkbox"/> No</p> <p>Measurement:</p>			<ul style="list-style-type: none"> • Adjust dispensers • Replace with or provide additional accessible dispensers •

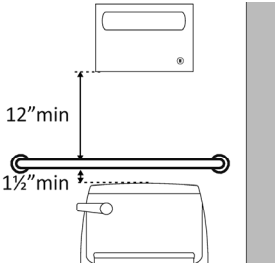
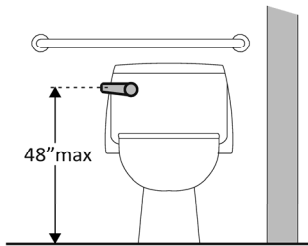
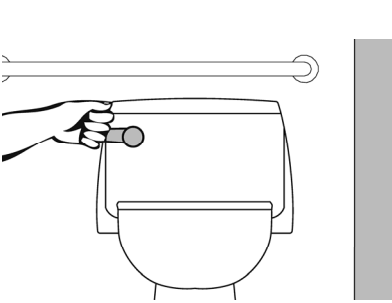
<p>Can the operable parts of the hand dryer or towel dispenser be operated without tight grasping, pinching or twisting of the wrist?</p> <p>Is the force required to activate the hand dryer or towel dispenser no greater than 5 pounds?</p>	<p><input type="checkbox"/> Yes <input type="checkbox"/> No</p> <p><input type="checkbox"/> Yes <input type="checkbox"/> No</p> <p>Measurement:</p>		<p>Photo #: 3.21</p>	
--	---	--	-----------------------------	--

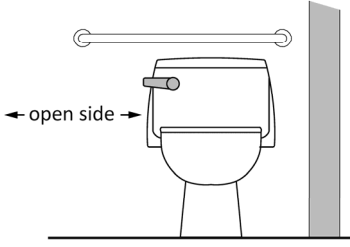
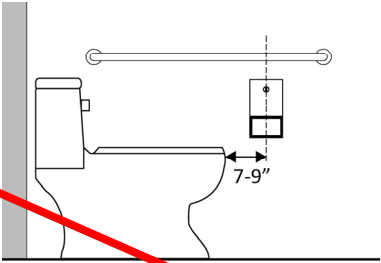
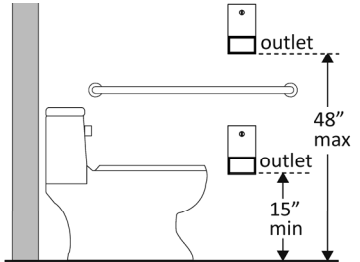
Water Closets in Single-User Toilet Rooms and Compartments (Stalls) (2010 Standards – 603 & 609) Note: 2010 Standards refer to toilets as water closets.

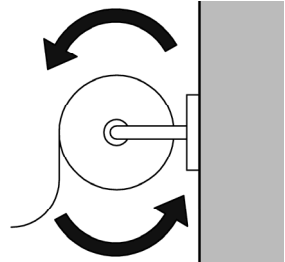
<p>3.30 Is the centerline of the water closet no less than 16 inches and no greater than 18 inches from the side wall or partition?</p>	<p><input type="checkbox"/> Yes <input checked="" type="checkbox"/> No</p> <p>Measurement: 24"</p>		<p>Photo #:</p>	<ul style="list-style-type: none"> • Move toilet • Replace toilet • Move partition •
<p>3.31 Is clearance provided around the water closet measuring at least 60 inches from the side wall and at least 56 inches from the rear wall?*</p>	<p><input type="checkbox"/> Yes <input checked="" type="checkbox"/> No</p> <p>Measurement: 48" FROM SIDE WALL 60" FROM REAR WALL</p>		<p>Photo #:</p>	<p>* If constructed before 3/15/12, clearances around water closets in single user toilet rooms can be 48 inches wide by 66 inches long or 48 inches wide by 56 inches long (depending on the approach to the water closet, see 1991 Standards Figure 28) and the lavatory may overlap that clearance if the door to the room does</p>

				<p>not swing into the required clearances at fixtures (such as lavatories, water closet and urinals) and the edge of the lavatory is at least 18 inches from the centerline of the water closet</p> <ul style="list-style-type: none"> Alter room/compartment for clearance
<p>3.32 Is the height of the water closet no less than 17 inches and no greater than 19 inches above the floor measured to the top of the seat?</p>	<p><input checked="" type="checkbox"/> Yes <input type="checkbox"/> No</p> <p>Measurement: 17"</p>		<p>Photo #: 3.21</p>	<ul style="list-style-type: none"> Adjust toilet height Replace toilet
<p>3.33 Is there a grab bar at least 42 inches long on the side wall?</p> <p>Is it located no more than 12 inches from the rear wall?</p> <p>Does it extend at least 54 inches from the rear wall?</p> <p>Is it mounted no less than 33 inches and no greater than 36 inches above the floor to the</p>	<p><input checked="" type="checkbox"/> Yes <input type="checkbox"/> No</p> <p>Measurement:</p> <p><input checked="" type="checkbox"/> Yes <input type="checkbox"/> No</p> <p>Measurement: 12"</p> <p><input checked="" type="checkbox"/> Yes <input type="checkbox"/> No</p> <p>Measurement: 54"</p> <p><input checked="" type="checkbox"/> Yes <input type="checkbox"/> No</p> <p>Measurement: 33"</p>			<ul style="list-style-type: none"> Install grab bar Relocate grab bar Relocate objects

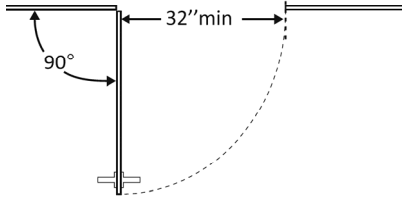
<p>top of the gripping surface?</p> <p>Is there at least 12 inches clearance between the grab bar and protruding objects above?*</p> <p>Is there at least 1½ inches clearance between the grab bar and projecting objects below?*</p> <p>Is the space between the wall and the grab bar 1 ½ inches?</p>	<p><input checked="" type="checkbox"/> Yes <input type="checkbox"/> No Measurement: NO PROTRUDING OBJECTS</p> <p><input checked="" type="checkbox"/> Yes <input type="checkbox"/> No Measurement: 2"</p> <p><input checked="" type="checkbox"/> Yes <input type="checkbox"/> No Measurement: 1 ½"</p>		<p>Photo #: 3.21</p>	<p>* If constructed before 3/15/2012 grab bars do not need to be relocated; there are no space requirements above and below grab bars in the 1991 Standards</p>
<p>3.34 Is there a grab bar at least 36 inches long on the rear wall?</p> <p>Does it extend at least 12 inches from the centerline of the water closet on one side (side wall)?</p> <p>Does it extend at least 24 inches on the other (open) side?</p> <p>Is it mounted no less than 33 inches and no greater than 36 inches above the floor to the top of the gripping surface?</p> <p>Are there at least 12 inches</p>	<p><input type="checkbox"/> Yes <input type="checkbox"/> No Measurement:</p> <p><input type="checkbox"/> Yes <input type="checkbox"/> No Measurement:</p> <p><input type="checkbox"/> Yes <input type="checkbox"/> No Measurement:</p> <p><input type="checkbox"/> Yes <input type="checkbox"/> No Measurement:</p> <p><input type="checkbox"/> Yes <input type="checkbox"/> No</p>		<p>NA</p> <p>Photo #:</p>	<ul style="list-style-type: none"> • Install grab bar • Relocate grab bar • Relocate objects •

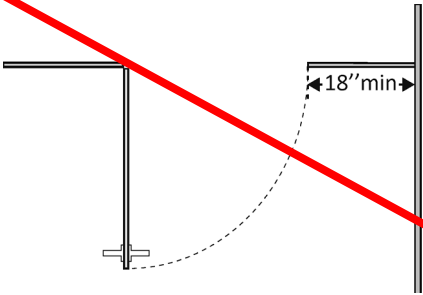
<p>clearance between the grab bar and protruding objects above?*</p> <p>Are there at least 1½ inches clearance between the grab bar and projecting objects below?*</p> <p>Is the space between the wall and the grab bar 1 ½ inches?</p>	<p>Measurement:</p> <p><input type="checkbox"/> Yes <input type="checkbox"/> No</p> <p>Measurement:</p> <p><input type="checkbox"/> Yes <input type="checkbox"/> No</p> <p>Measurement:</p>		<p style="text-align: center; color: red; font-weight: bold;">NA</p> <p>Photo #:</p>	<p>* If constructed before 3/15/2012 grab bars do not need to be relocated; there are no space requirements above and below grab bars in the 1991 Standards</p>
<p>3.35 If the flush control is hand operated, is the operable part located no higher than 48 inches above the floor?</p>	<p><input checked="" type="checkbox"/> Yes <input type="checkbox"/> No</p> <p>Measurement:</p> <p style="color: red; font-weight: bold;">30"</p>		<p>Photo #: 3.21</p>	<ul style="list-style-type: none"> • Move control • Install sensor with override button no higher than 48 inches •
<p>3.36 If the flush control is hand operated, can it be operated with one hand and without tight grasping, pinching, or twisting of the wrist?</p> <p>Is the force required to activate the flush control no greater than 5 pounds?</p>	<p><input checked="" type="checkbox"/> Yes <input type="checkbox"/> No</p> <p><input type="checkbox"/> Yes <input type="checkbox"/> No</p> <p>Measurement:</p>		<p>Photo #: 3.21</p>	<ul style="list-style-type: none"> • Change control • Adjust control •

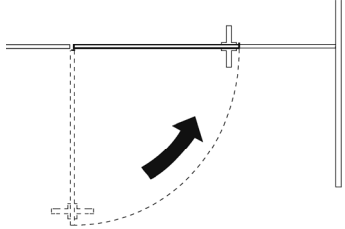
<p>3.37 Is the flush control on the open side of the water closet?</p>	<p><input checked="" type="checkbox"/> Yes <input type="checkbox"/> No</p>		<p>Photo #: 3.21</p>	<ul style="list-style-type: none"> • Move control • •
<p>3.38 Is the toilet paper dispenser located no less than 7 inches and no greater than 9 inches from the front of the water closet to the centerline of the dispenser?*</p>	<p><input type="checkbox"/> Yes <input type="checkbox"/> No</p> <p>Measurement:</p>		<p>Photo #:</p>	<p>* If constructed before 3/15/2012 dispenser does not need to be relocated if it is within reach from the water closet seat; the 1991 Standards do not specify distance from the front of the water closet</p> <ul style="list-style-type: none"> • Relocate dispenser • •
<p>3.39 Is the outlet of the dispenser:</p> <p>Located no less than 15 inches and no greater than 48 inches above the floor?</p> <p>Not located behind grab bars?</p>	<p><input type="checkbox"/> Yes <input type="checkbox"/> No</p> <p>Measurement:</p> <p><input type="checkbox"/> Yes <input type="checkbox"/> No</p>		<p>Photo #:</p>	<ul style="list-style-type: none"> • Relocate dispenser • •

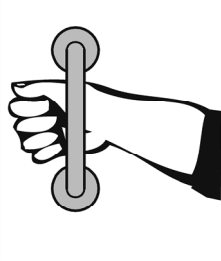
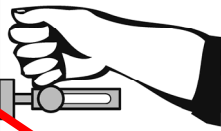
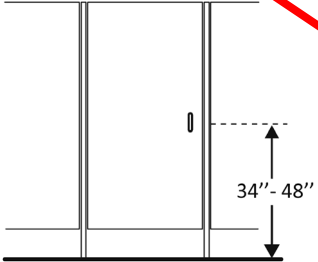
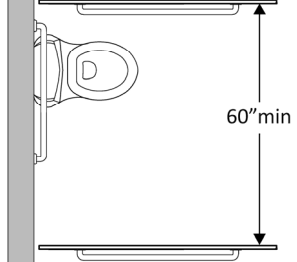
<p>3.40 Does the dispenser allow continuous paper flow?</p>	<p><input checked="" type="checkbox"/> Yes <input type="checkbox"/> No</p>		<p>Photo #: 3.21</p>	<ul style="list-style-type: none"> • Adjust dispenser • Replace dispenser •
--	--	---	-----------------------------	--

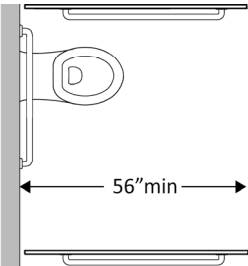
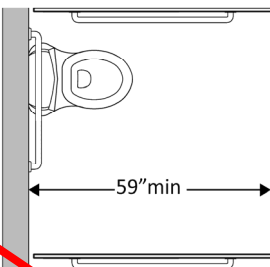
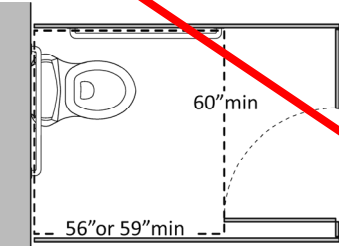
Toilet Compartments (Stalls) (2010 Standards – 604)

<p>3.41 Is the door opening width at least 32 inches clear, between the face of the door and the stop, when the door is open 90 degrees?</p>	<p><input type="checkbox"/> Yes <input type="checkbox"/> No</p> <p>Measurement:</p>		<p>Photo #:</p>	<ul style="list-style-type: none"> • Widen door width • •
---	---	--	-----------------	--

<p>3.42 If there is a front approach to the pull side of the door, is there at least 18 inches of maneuvering clearance beyond the latch side plus 60 inches clear depth?*</p>	<p><input type="checkbox"/> Yes <input type="checkbox"/> No</p> <p>Measurement:</p>		<p>Photo #:</p>	<p>*See 2010 Standards 604.8.1.2 Doors for maneuvering clearance requirements on the push side of the door and side approaches to the pull side of the door</p> <ul style="list-style-type: none"> • Remove obstructions •
---	---	---	-----------------	--

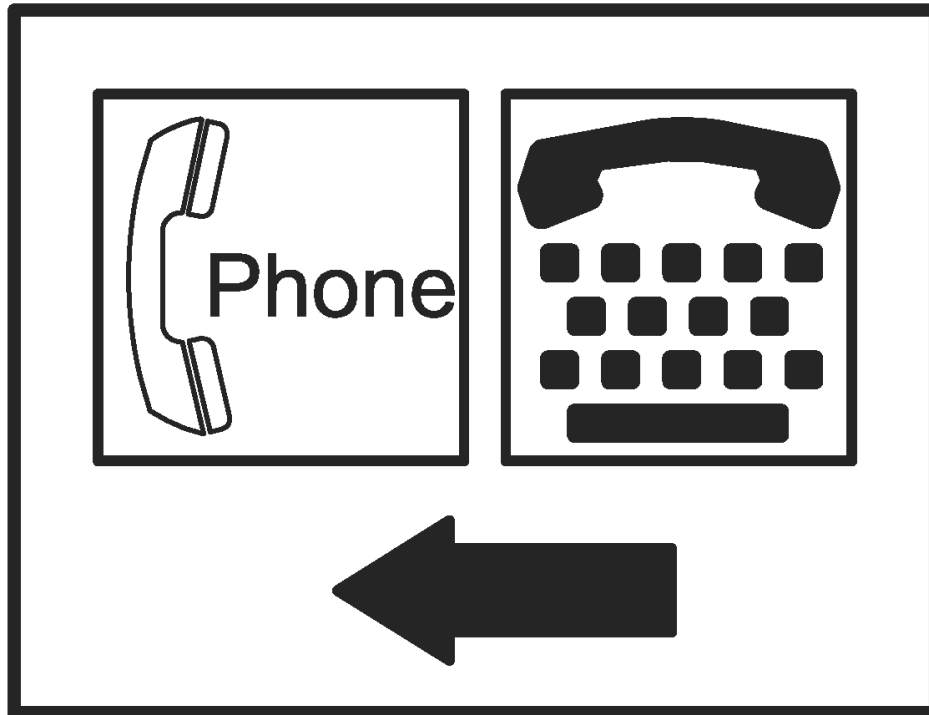
<p>3.43 Is the door self-closing?</p>	<p><input type="checkbox"/> Yes <input type="checkbox"/> No</p>		<p>Photo #:</p>	<ul style="list-style-type: none"> • Add closer • Replace door
--	---	--	-----------------	--

<p>3.44 Are there door pulls on both sides of the door that are operable with one hand and do not require tight grasping pinching or twisting of the wrist?*</p>	<p><input type="checkbox"/> Yes <input type="checkbox"/> No</p>		<p>Photo #:</p>	<p>* If constructed before 3/15/2012 door pulls do not need to be added; door pulls are not required in the 1991 Standards</p> <ul style="list-style-type: none"> • Replace hardware • •
<p>3.45 Is the lock operable with one hand and without tight grasping, pinching or twisting of the wrist?</p>	<p><input type="checkbox"/> Yes <input type="checkbox"/> No</p>		<p>Photo #:</p>	<ul style="list-style-type: none"> • Replace lock • •
<p>3.46 Are the operable parts of the door hardware mounted no less than 34 inches and no greater than 48 inches above the floor?</p>	<p><input type="checkbox"/> Yes <input type="checkbox"/> No Measurement:</p>		<p>Photo #:</p>	<ul style="list-style-type: none"> • Relocate hardware • •
<p>3.47 Is the compartment at least 60 inches wide?</p>	<p><input type="checkbox"/> Yes <input type="checkbox"/> No Measurement:</p>		<p>Photo #:</p>	<ul style="list-style-type: none"> • Widen compartment •

<p>3.48 If the water closet is wall hung, is the compartment at least 56 inches deep?</p>	<p><input type="checkbox"/> Yes <input type="checkbox"/> No Measurement:</p>		<p>Photo #:</p>	<ul style="list-style-type: none"> • Widen compartment • •
<p>3.49 If the water closet is floor mounted, is the compartment at least 59 inches deep?</p>	<p><input type="checkbox"/> Yes <input type="checkbox"/> No Measurement:</p>		<p>Photo #:</p>	<ul style="list-style-type: none"> • Alter compartment • •
<p>3.50 If the door swings in, is the minimum required compartment area provided beyond the swing of the door (60 inches x 56 inches if water closet is wall hung or 59 inches if water closet is floor mounted)?</p>	<p><input type="checkbox"/> Yes <input type="checkbox"/> No Measurement:</p>		<p>Photo #:</p>	<ul style="list-style-type: none"> • Reverse door swing • Alter compartment •
<p></p>	<p><input type="checkbox"/> Yes <input type="checkbox"/> No</p>	<p></p>	<p>Photo #:</p>	<ul style="list-style-type: none"> • • •
<p></p>	<p><input type="checkbox"/> Yes <input type="checkbox"/> No</p>	<p></p>	<p>Photo #:</p>	<ul style="list-style-type: none"> • • •

ADA Checklist for Readily Achievable Barrier Removal

Priority 4 – Additional Access



Project **SDDOT Rest Area Improvements**

FHU Reference Number 13-039-01

TSP Project Number 03120855

Building **VALLEY SPRINGS POE**

Location **90 W., MRM 412**

Date **09-18-2013 (Inspection)**

Surveyors **Timothy Roach, AIA**

Todd Schultz, PE

Robert King, CPD

Contact Information **TSP – (605) 343-6102**

Amenities such as drinking fountains and public telephones should be accessible to people with disabilities.



Institute for Human Centered Design

www.HumanCenteredDesign.org

November 2011



ADA National Network

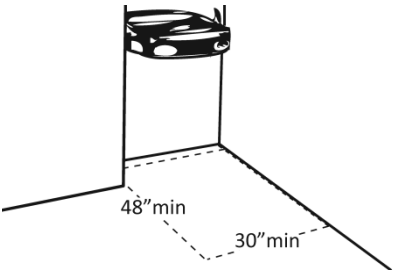
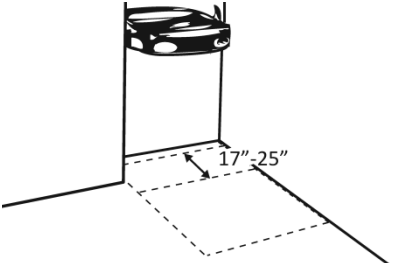
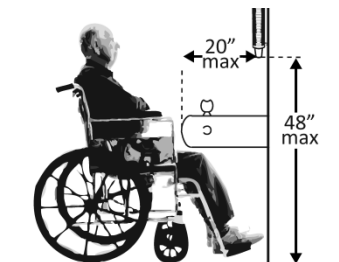
Questions on the ADA 800-949-4232 voice/tty

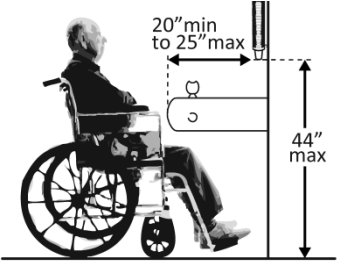

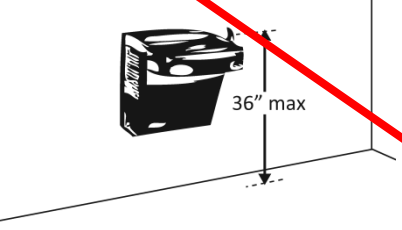
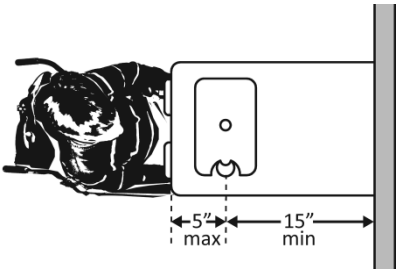
www.ADAchecklist.org

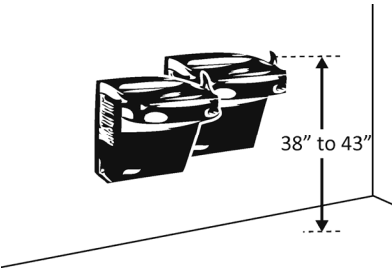
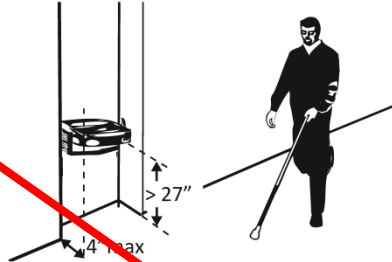
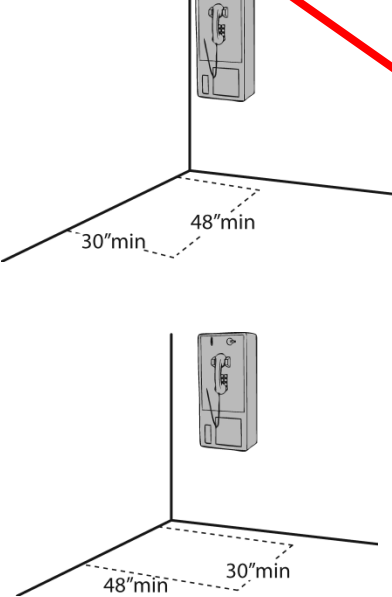
This checklist was produced by the New England ADA Center, a project of the Institute for Human Centered Design and a member of the ADA National Network. This checklist was developed under a grant from the Department of Education, NIDRR grant number H133A060092-09A. However the contents do not necessarily represent the policy of the Department of Education, and you should not assume endorsement by the Federal Government.

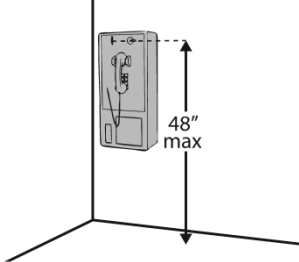
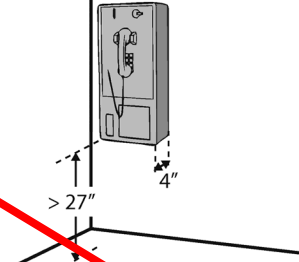


Questions or comments on the checklist contact the New England ADA Center at 617-695-0085 voice/tty or ADAinfo@NewEnglandADA.org




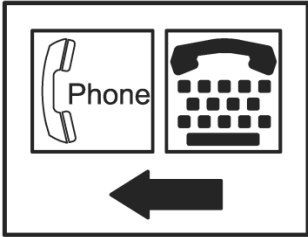
For the full set of checklists, including the checklists for recreation facilities visit www.ADAchecklist.org.




Priority 4 – Additional Access		Comments	Possible Solutions
Drinking Fountains (2010 Standards – 602)			
<p>4.1 Does at least one drinking fountain have a clear floor space at least 30 inches wide x at least 48 inches long centered in front of it for a forward approach?*</p>	<p><input checked="" type="checkbox"/> Yes <input type="checkbox"/> No</p> <p>Measurement: 48x30</p>	 <p>48" min 30" min</p>	<p>CULLIGAN FILTERED WATER DISPENSER. APPROX 12X12X36</p> <p>Photo #: 4.1</p> <p>*If installed before 3/15/2012, a parallel approach is permitted and the clear floor space is not required to be centered</p> <ul style="list-style-type: none"> • Alter space • Relocate drinking fountain • Install a drinking fountain in another location
<p>4.2 If there is a forward approach, do no less than 17 inches and no greater than 25 inches of the clear floor space extend under the drinking fountain?</p>	<p><input type="checkbox"/> Yes <input type="checkbox"/> No</p> <p>Measurement:</p>	 <p>17"-25"</p>	<p>Photo #: NA</p> <ul style="list-style-type: none"> • Alter space • Replace drinking fountain •
<p>4.3 If the drinking fountain is no deeper than 20 inches, are the operable parts no higher than 48 inches above the floor?</p>	<p><input type="checkbox"/> Yes <input type="checkbox"/> No</p> <p>Measurement:</p>	 <p>20" max 48" max</p>	<p>Photo #: NA</p> <ul style="list-style-type: none"> • Adjust drinking fountain • Replace drinking fountain •

<p>4.4 If the drinking fountain is no less than 20 inches and no greater than 25 inches deep, are the operable parts no higher than 44 inches above the floor?</p>	<p><input type="checkbox"/> Yes <input type="checkbox"/> No</p> <p>Measurement:</p>		<p>Photo #:</p>	<ul style="list-style-type: none"> • Adjust drinking fountain • Replace drinking fountain •
<p>4.5 Can the control be operated with one hand and without tight grasping, pinching or twisting of the wrist?</p> <p>Is the force required to activate the control no more than 5 pounds?</p>	<p><input type="checkbox"/> Yes <input type="checkbox"/> No</p> <p><input type="checkbox"/> Yes <input type="checkbox"/> No</p> <p>Measurement:</p>		<p>Photo #:</p>	<ul style="list-style-type: none"> • Change control • Adjust control •
<p>4.6 Is the spout outlet no higher than 36 inches above the floor?</p>	<p><input type="checkbox"/> Yes <input type="checkbox"/> No</p> <p>Measurement:</p>		<p>Photo #:</p>	<ul style="list-style-type: none"> • Adjust drinking fountain • Replace drinking fountain •
<p>4.7 Is the spout:</p> <p>At least 15 inches from the rear of the drinking fountain?</p> <p>No more than 5 inches from the front of the drinking fountain?</p>	<p><input type="checkbox"/> Yes <input type="checkbox"/> No</p> <p>Measurement:</p> <p><input type="checkbox"/> Yes <input type="checkbox"/> No</p> <p>Measurement:</p>		<p>Photo #:</p>	<ul style="list-style-type: none"> • Adjust spout • Replace drinking fountain •

<p>4.8 If there is more than one drinking fountain, is there at least one for standing persons?</p> <p>Is the spout outlet no lower than 38 inches and no higher than 43 inches above the floor?</p>	<p><input type="checkbox"/> Yes <input type="checkbox"/> No</p> <p><input type="checkbox"/> Yes <input type="checkbox"/> No</p> <p>Measurement:</p>		<p>Photo #:</p>	<ul style="list-style-type: none"> • Adjust drinking fountain • Install new drinking fountain for standing height •
<p>4.9 If the leading (bottom) edge of the fountain is higher than 27 inches above the floor, does the front of the fountain protrude no more than 4 inches into the circulation path?</p>	<p><input type="checkbox"/> Yes <input type="checkbox"/> No</p> <p>Measurement:</p>		<p>Photo #:</p>	<ul style="list-style-type: none"> • Adjust drinking fountain • Replace drinking fountain • Add tactile warning such as permanent planter or partial walls
<p>Public Telephones (2010 Standards – 704) TTY's are devices that employ interactive text-based communication through the transmission of coded signals across the telephone network. They are mainly used by people who are deaf and/or cannot speak.</p>				
<p>4.10 Does at least one telephone have a clear floor space at least 30 inches wide x at least 48 inches long for a parallel or forward approach?</p>	<p><input type="checkbox"/> Yes <input type="checkbox"/> No</p>		<p>Photo #:</p>	<ul style="list-style-type: none"> • Move telephone • Install new telephone for clear floor space •

<p>4.11 Is the highest operable part of the telephone no higher than 48 inches above the floor?</p>	<p><input type="checkbox"/> Yes <input type="checkbox"/> No</p> <p>Measurement:</p>		<p>Photo #:</p>	<ul style="list-style-type: none"> • Adjust telephone • •
<p>4.12 If the leading (bottom) edge of the telephone is higher than 27 inches above the floor, does the front of the telephone protrude no more than 4 inches into the circulation path?</p>	<p><input type="checkbox"/> Yes <input type="checkbox"/> No</p> <p>Measurement:</p>		<p>Photo #:</p>	<ul style="list-style-type: none"> • Adjust telephone • •
<p>4.13 Does at least one telephone have a volume control?</p>	<p><input type="checkbox"/> Yes <input type="checkbox"/> No</p>		<p>Photo #:</p>	<ul style="list-style-type: none"> • Install volume control • Replace telephone with one that has volume control •
<p>4.14 Is the volume control identified by a pictogram of a telephone handset with radiating sound waves?</p>	<p><input type="checkbox"/> Yes <input type="checkbox"/> No</p>		<p>Photo #:</p>	<ul style="list-style-type: none"> • Add pictogram • •

<p>4.15 Does at least one telephone have a TTY?</p>	<p><input type="checkbox"/> Yes <input type="checkbox"/> No</p>		<p>Photo #:</p>	<ul style="list-style-type: none"> • Install TTY • •
<p>4.16 Is the touch surface of the TTY keypad at least 34 inches above the floor?</p>	<p><input type="checkbox"/> Yes <input type="checkbox"/> No Measurement:</p>		<p>Photo #:</p>	<ul style="list-style-type: none"> • If a seat is provided, TTY is not required to be 34 inches minimum above the floor • Adjust height of TTY •
<p>4.17 Is the TTY identified by the International Symbol of TTY?</p>	<p><input type="checkbox"/> Yes <input type="checkbox"/> No</p>		<p>Photo #:</p>	<ul style="list-style-type: none"> • Add symbol • •
<p>4.18 Do signs that provide direction to public telephones also provide direction to the TTY?</p>	<p><input type="checkbox"/> Yes <input type="checkbox"/> No</p>		<p>Photo #:</p>	<ul style="list-style-type: none"> • Add signs • •

<p>4.19 Do telephones that do not have a TTY provide direction to the TTY?</p>	<p><input type="checkbox"/> Yes <input type="checkbox"/> No</p>	 	<p>Photo #:</p>	<ul style="list-style-type: none"> • Add signs • •
<p>Fire Alarm Systems (2010 Standards – 702)</p>				
<p>4.20 If there are fire alarm systems, do they have both flashing lights and audible signals?</p>	<p><input type="checkbox"/> Yes <input type="checkbox"/> No</p>		<p>Photo #:</p>	<ul style="list-style-type: none"> • Install audible and visual alarms • •
	<p><input type="checkbox"/> Yes <input type="checkbox"/> No</p>		<p>Photo #:</p>	<ul style="list-style-type: none"> • • •
	<p><input type="checkbox"/> Yes <input type="checkbox"/> No</p>		<p>Photo #:</p>	<ul style="list-style-type: none"> • • •
	<p><input type="checkbox"/> Yes <input type="checkbox"/> No</p>		<p>Photo #:</p>	<ul style="list-style-type: none"> • • •

Valley Springs POE PRIORITY 1



Photo #1.1



Photo #1.1a



Photo #1.2 10-04-2013



Photo #1.13 10-04-2013

Valley Springs POE PRIORITY 1



Photo #1.31 10-04-2013



Photo #1.41 10-04-2013 051

Valley Springs POE PRIORITY 2

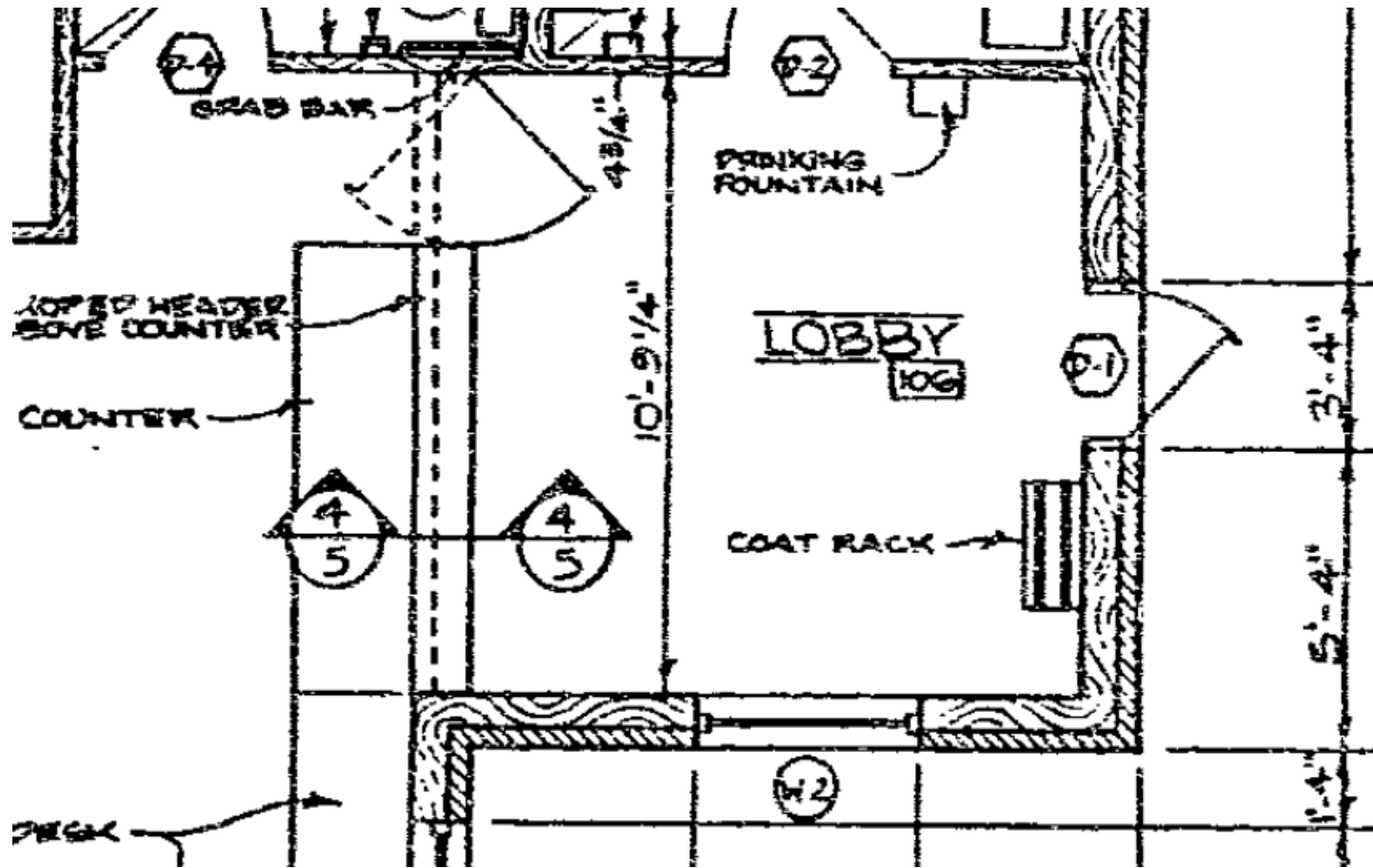


Photo #2.1 Valley Springs POE Lobby

Valley Springs POE PRIORITY 2

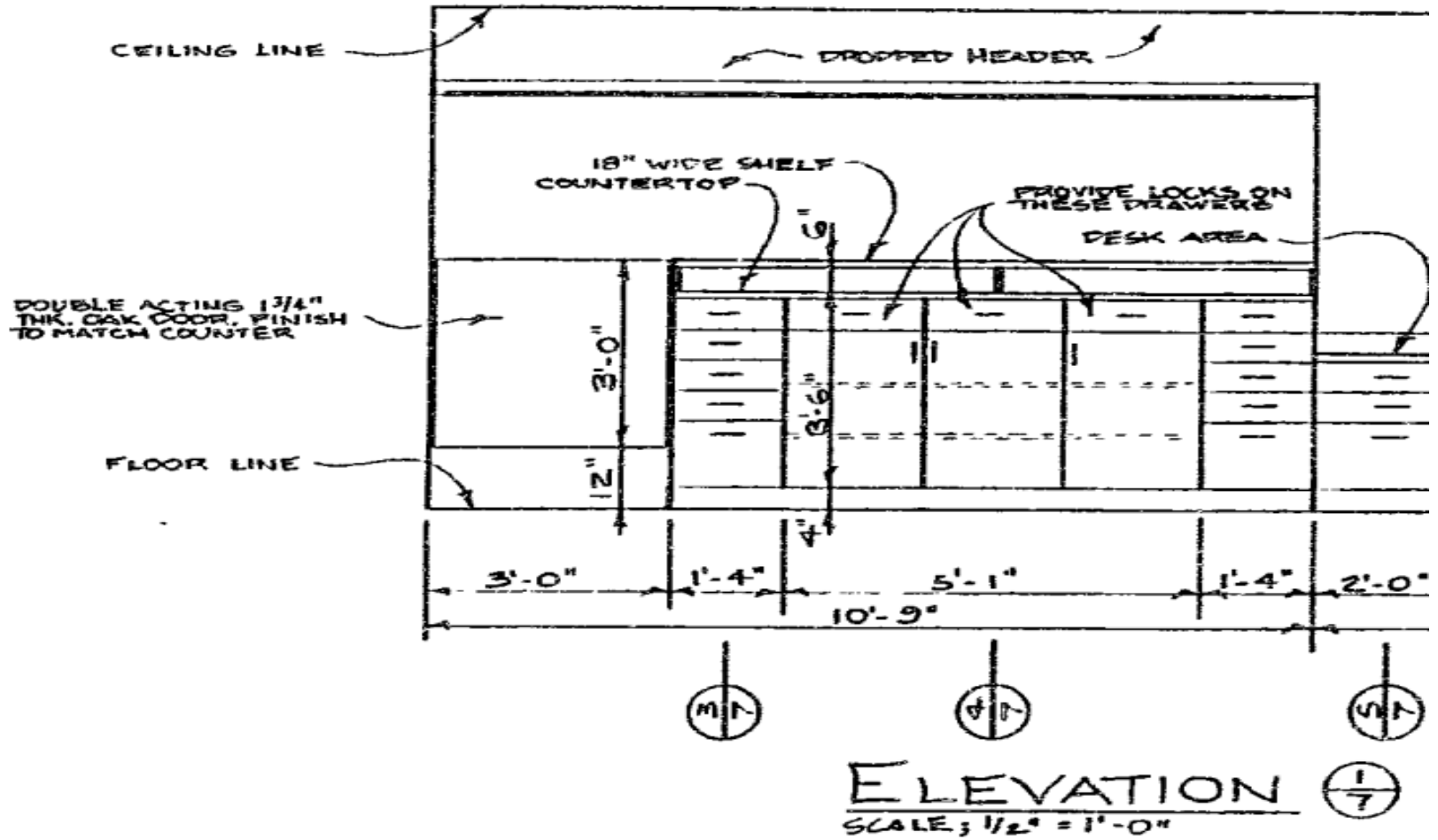


Photo #2.76 Valley Springs POE counter

Valley Springs POE PRIORITY 2



Photo #Valley Springs Site 056

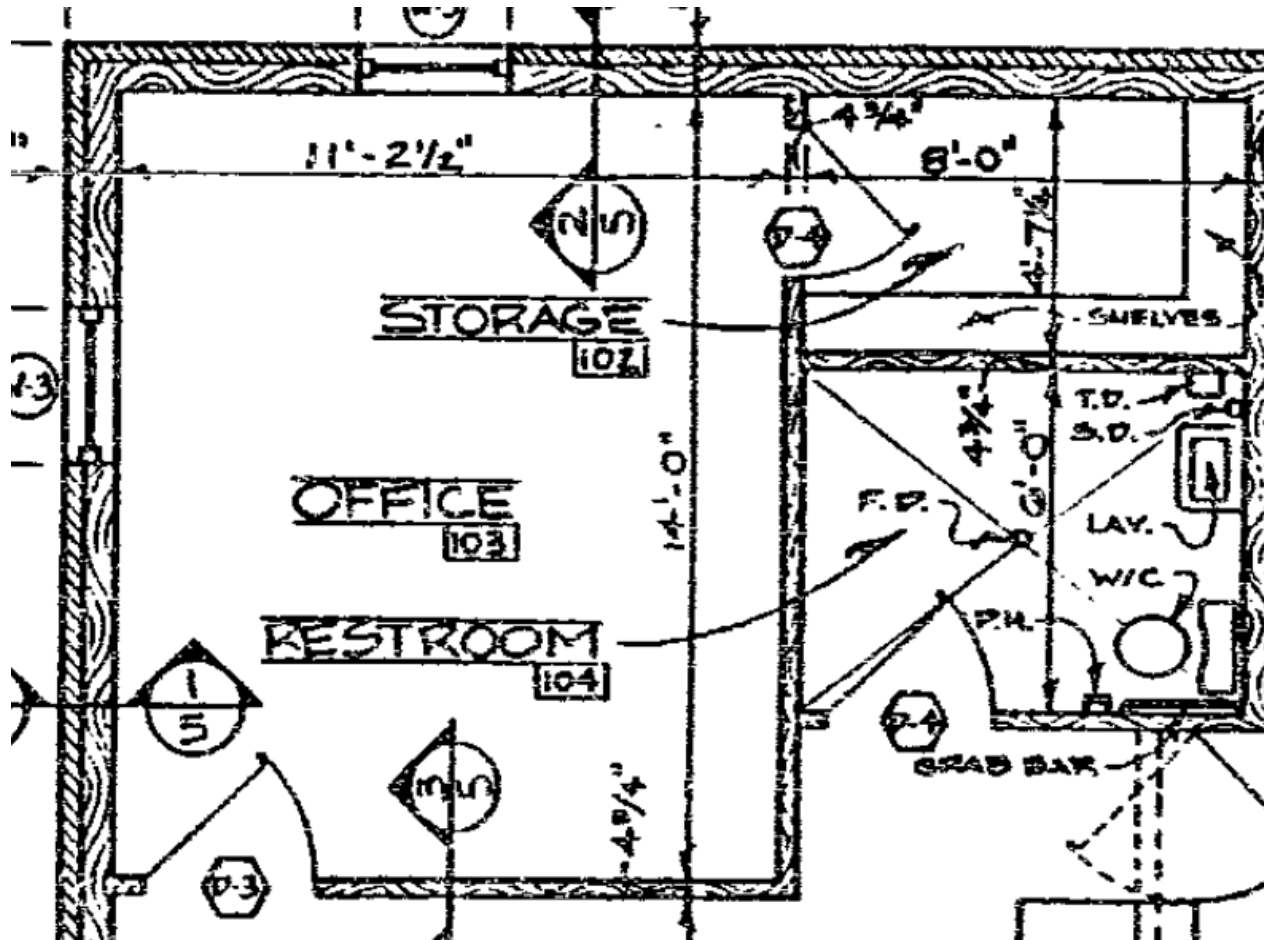


Photo #3.1 Off.-Stor.-Toilet

Valley Springs POE PRIORITY 3

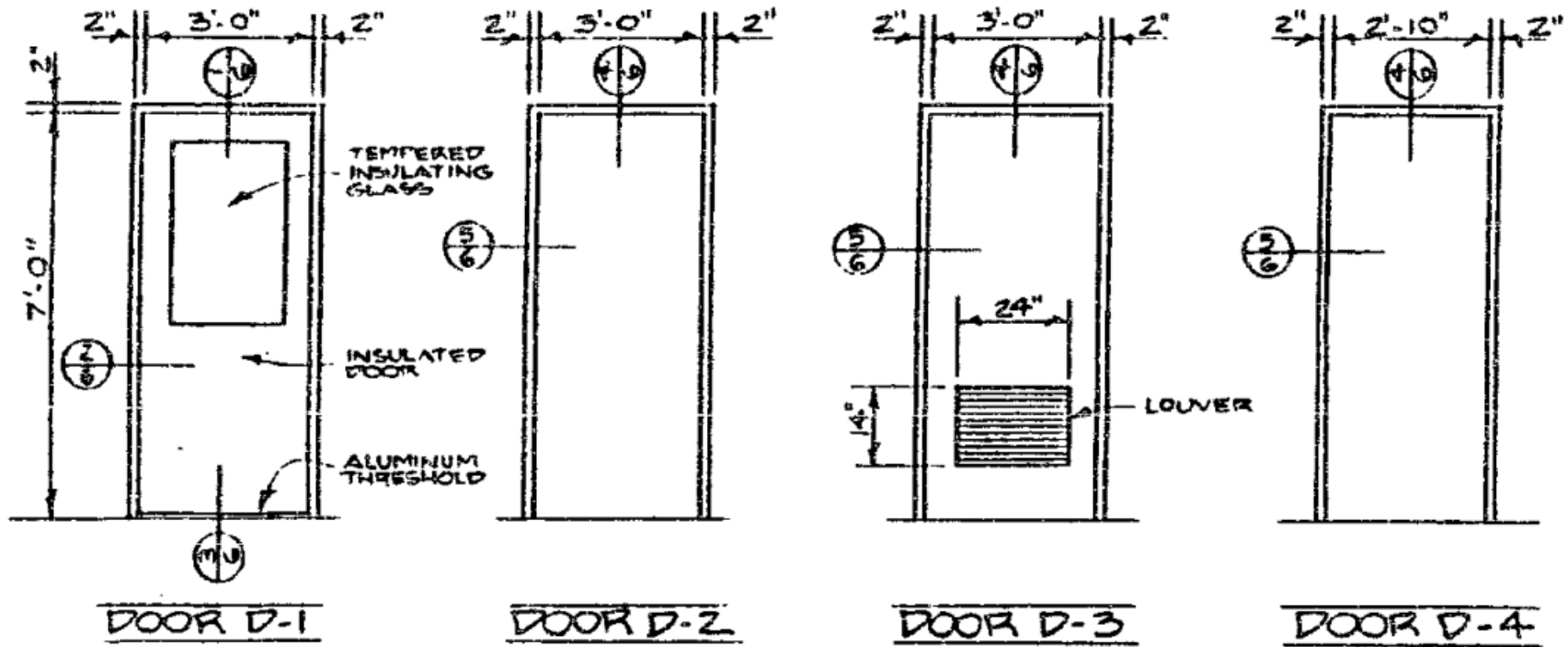


Photo #3.6 Doors

Valley Springs POE PRIORITY 3



Photo #3.6

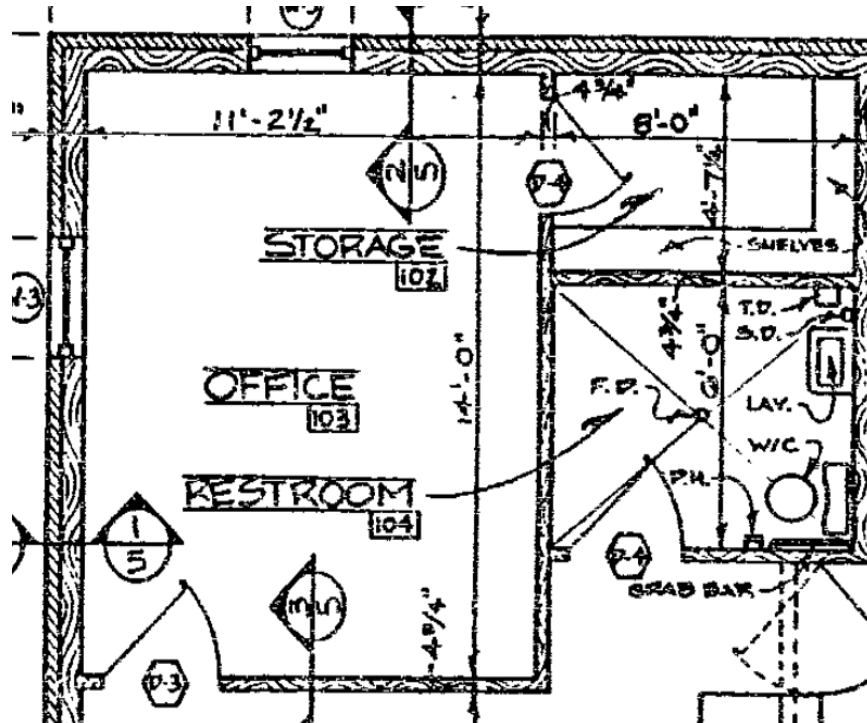


Photo #3.7 Off.-Stor.-Toilet

Valley Springs POE PRIORITY 3



Photo #3.9 IMG_7651



Photo #3.21 7653

Valley Springs POE PRIORITY 4



Photo #4.1 Valley Springs Site 045



The Interstate Rest Areas Study: Along the I-29 and I-90 Corridors

APPENDIX C AUDITMATE SUMMARY

Detailed Component List for One Facility
MINN_WGH Sioux Falls Port of Entry Weigh Station

9/25/2013

Class	Component	Comment	Quantity	Unit Cost	Lifespan	Age	Installed	Renewal Cost (RC)	Deferred Cost (DC)
Site Structures									
	10x10 Steel Storage Unit (exterior)		1						
Exterior Closure									
	Masonry Wall Mortar, Concrete Mortar	Some repairs showing, needs cleaning and tuckpointing							
	Paint or Stain, Exterior	Weathered							
	Steel Single Door								
	Aluminum Frame and Glazing								
	Metal Window, Double Pane, Large Opening w/Hopper								
	Metal Window, Double Pane, Medium Opening								
Roofing and Drainage									
	Asphalt Shingle Roof								
	Downspouts, Aluminum								
	Gutters, Aluminum, Hung								
Interior Construction									
	Painting, Interior, Average Grade	Worn and needs refinishing							
	Carpet, Roll Goods	very worn							
	Vinyl Composition Tile	very worn							
	Acoustical Ceiling Tile, Spline, 12" x 12"	very worn							
	Built in Counters and shelving	very worn							
	Interior Doors and hardware	very worn							
Plumbing									
	Water Heater, Residential, Electric, 10-20 Gallons	Fully operational. However, beyond it's expected service life.			12				
	Faucet (Lavatory)	Faucet is two handle, manual type. Does not meet ADA requirements. It is deteriorated due to age.			20				
	Lavatory Sink, Wall-Hung	Fixture is showing wear and deterioration due to age.			40				
	Slop Sink, Single Bowl, Enamel - Wall mounted	Fully operational. Only preventive maintenance is required.			40				
	Water Closet, Porcelain, Tank type, Floor-Mounted	Fully operational. Replacing unit with a low water consumption fixture will extend the life of the lagoon.	8 each		40				
	Waste and Vent Piping, above floor	Appears to be in good condition, no apparent leaks.			50	29	1984		
	Waste piping - under floor	Fully operational. Waste piping is a combination of cast iron pipe installed in 1980 and PVC plastic pipe installed in 1992			40	33	1980		
	Water Piping	Appears to be in good condition.			50	29	1984		

Detailed Component List for One Facility
MINN_WGH Sioux Falls Port of Entry Weigh Station

9/25/2013

Class	Component	Comment	Quantity	Unit Cost	Lifespan	Age	Installed	Renewal Cost (RC)	Deferred Cost (DC)
	Piping Insulation	Piping insulation is fabric jacketed insulation. Insulation appears to be intact and will only need minor repair if damaged or modified.			30	29	1984		
	Valves	Valves are starting to exhibit some corrosion. Valves may need repair or replacement soon.			50	29	1984		
	Pipe Hangers and Supports	Appears to be in good condition.			50	29	1984		
Mechanical									
	Split System Heat Pump Outdoor Condensing Unit, 02.5-3 Ton	Like new with no defects. Only routine maintenance is needed.	2 each		20	1	2012		
	Air Handling Unit, Split System, Heat Pump, 02.5-3 - Indoor Unit	Like new with no defects. Only routine maintenance is needed.	2 each		20	1	2012		
	Exhaust fan/light - Ceiling (Kitchen or Bathroom)	Operational. Deteriorated due to age.	1 each		25	29	1984		
	Exhaust fan/light - Ceiling (Equipment Room)	Fan/Light is not operational.	1 each		25	29	1984		
	Air Distribution Ducts	Ducts, where visible, seem to be in good condition. No air leakage noted.			50	29	1984		
	Duct Insulation	Ducts are not insulated			50	29	1984		
	Supply and return air outlets/inlets	Units are in operable condition. However, they are showing signs of deterioration.	7 each		50	29	1984		
	Temperature Controls	Like new with ne defects. Only routine maintenance is needed.	1 each		20	1	2012		
Electrical									
	Transformer, 3 PH, 240/480 to 120/208V, 0030 KVA		1 each	\$3,293.67	50	29	1984	\$3,294	\$0
	Panelboard, Main Breaker, 1 PH, 240V, 0200-0250A	Fully operational, only preventive maintenance required	1 each	\$5,253.07	50	29	1984	\$5,253	\$0
	Fluorescent Fixture, 2' x 4', T-12	Fully operational, lamps are hard to get and expensive	2 each	\$296.86	40	29	1984	\$594	\$594
	Fluorescent Fixture, 2' x 4', T-12	Fully operational, lamps are hard to get and expensive	6 each	\$296.86	40	29	1984	\$1,781	\$1,781
	Incandescent Fixture, Recessed	Fully operational, consider upgrading lamps to more efficient type.	1 each	\$160.87	40	29	1984	\$161	\$0
	Incandescent Fixture, Surface Mounted, Stock	Fully operational, consider upgrading lamps to more efficient type.	4 each	\$184.27	40	29	1984	\$737	\$0
	Light Pole, Steel	Fully operational, only preventive maintenance required.	6 each	\$2,129.93	40	29	1984	\$12,780	\$0
	Outdoor fixture, Cobrahead	Fully operational, only preventive maintenance required.	6 each	\$3,600.00	40	29	1984	\$21,600	\$0
	Outdoor Fixture, Surface-Mounted, HID, Stock, Small	Fully operational, some lenses show deterioration.	2 each	\$240.00	40	29	1984	\$480	\$0
	Outdoor Fixture, surface-Mounted, Incandescent	Fully operational, only preventive maintenance required.	1 each		50	29	1984	\$1,399	\$0
	Outdoor Fixture, surface-Mounted, Incandescent	Fully operational, only preventive maintenance required.	5 each	\$279.73	40	8	2005	\$1,399	\$0

Detailed Component List for One Facility
MINN_WGH Sioux Falls Port of Entry Weigh Station

9/25/2013

Class	Component	Comment	Quantity	Unit Cost	Lifespan	Age	Installed	Renewal Cost (RC)	Deferred Cost (DC)
Fire Protection									
	Emergency Exit Light	Fixture lamp is not operational	1 each	\$447.35	40	29	1984	\$447	\$0
Utilities									
Sanitary Sewer System									
	Lagoons	The POE shares the sewage lagoons with the rest area.							
	Sewage Piping System	No problems have been reported concerning the sewer pipes and manholes.							
Water System (Rural Water)									
	Water Pipe System	The POE shares the water system with the rest area. No problems reported concerning the water system.							
Infrastructure									
	Parking Area, Asphalt - 6"	Asphalt parking area is in bad shape. Approximately 2/3 of the asphalt should be removed and replaced. The other 1/3 needs to be chip sealed.							
	Parking Area, Non Reinforced Concrete 9.5"	Most of the concrete pavement is in good shape. Approximately 10-15% of the panels will need to be replaced in the next 5-10 years. Joint repair and sealing needs to be done periodically.							
	Sidewalk, Concrete	Concrete walk generally is in good shape. Maintenance at the back of the building to remove grass and weeds from along the trench drain would help with drainage. The ramp to the east of the building needs some repair and updating to bring it into compliance with ADA							
	Landscaping	Very little landscaping in the POE area. An area of grass inside of the truck turnaround area is basically the extent of landscaping. The grass is in good shape.							
	Wayfinding Signage	Signage is in good shape, but could use modernization.							

**HOMESTEAD
REST AREA**

TECHNICAL REVIEW REPORT

Prepared for:

Mr. Brad Remmich
South Dakota Department of Transportation
Office of Project Development
700 East Broadway Avenue
Pierre, SD 57501-2586
(605) 773-3093

Prepared by:

TSP
600 Kansas City Street
Rapid City, SD 57701-2712
(605) 343-6102

Felsburg Holt & Ullevig
6300 South Syracuse Way, Suite 600
Centennial, CO 80111
(303) 721-1440

FHU Reference No. 113039-01
December 2013



The Interstate Rest Areas Study: Along the I-29 and I-90 Corridors

TABLE OF CONTENTS

	<u>Page</u>
I. INTRODUCTION -----	1
II. GENERAL OVERVIEW -----	2
A. Rest Area Layout -----	2
B. Field Visit Observations -----	4
C. User Environment -----	4
D. Existing Building Code Conformity -----	5
E. Americans with Disabilities Act (ADA) Survey -----	5
F. Energy and Water Usage Review -----	7
III. BUILDING SYSTEM OVERVIEW -----	8
A. Architectural System -----	8
B. Plumbing System -----	8
C. Mechanical System -----	8
D. Electrical System -----	9
E. Sanitary Sewer System -----	9
F. Water System -----	9
G. Infrastructure -----	10
IV. SUMMARY -----	11

APPENDIX A MAINTENANCE STAFF MEETING MINUTES

APPENDIX B ADA SURVEY RESULTS

APPENDIX C AUDITMATE SUMMARY

LIST OF FIGURES

	<u>Page</u>
Figure 1. Homestead Rest Area Site Layout -----	3



I. INTRODUCTION

The Homestead Rest Area is located to the east of the Interstate 29 corridor, off SD50, in the southeast corner of South Dakota. More specifically, the rest area is approximately 50 miles south of Sioux Falls and 7 miles east of Vermillion on SD50. The facility does not directly access Interstate 29, and services both northbound and southbound Interstate 29 and SD50 traffic.

The site includes the main rest area facility, teepee tower/sculpture, picnic structures, a small state police facility / storage garage, a dump station (closed), and segregated truck and passenger vehicle parking. The main facility includes restrooms, and a manned information counter that is staffed during summer months. The facility also includes a partial basement used for mechanical equipment, workshop, and storage.

The purpose of this report is to summarize the condition of existing site components and building systems for the facility as a whole. The intent for this report is to define the general status of the existing facilities given their age and use.

The report has been divided into two general areas of focus. The first section includes a general overview of the facility design and operations. Architectural issues, including the general capacity of the facilities and current operations, are reviewed and compared to current facility standards (i.e., building codes, ADA, etc.).

The systems overview section covers the type and condition of the components that make up the facility, and includes a summary evaluation of the site and building infrastructure. The site infrastructure repairs/replacement review includes sidewalks, lighting, signage, landscaping, and picnic shelters. The building systems infrastructure review includes items such as the building shell and structure, mechanical and plumbing systems, electrical, interior finishes, and communications/IT equipment.



II. GENERAL OVERVIEW

A. Rest Area Layout

The rest area is accessed from SD50, just east of the I-29 interchange. The main facility is centered within the site and bordered by the parking lot and access road. Picnic areas are located both north and south of the main visitor center building. The rest area provides one centralized parking lot, with separate areas for passenger vehicles and trucks. On the south east end of the parking lot is a state police structure (approximately 1,000 square feet) and small garage, which were not reviewed in this report. On the north east end of the parking lot is a small storage garage for maintenance equipment, and long term storage of marketing materials. Two sewage ponds which support the facility are located to the south of the main parking lot.

Outdoor facilities include:

- One 20'x32' framed storage garage
- Nine dual picnic shelters (2 concrete tables ea.) approx. 14'x27'
- One exterior visitor display structure
- Exterior uncovered vending machines and advertising equipment
- One lodgepole/teepee sculpture
- Dumping station
- Flag pole

Utilities Include:

- Rural water system with underground steel tank and pump
- Gravity sewer system with lagoons with pump at manhole just upstream of lagoons
- No city gas or propane tanks
- Electric power and transformer
- Telephone service

The main structure is 1,773 square feet. On the north side of the structure, under the men's restroom and storage room, is a 700 square foot basement. Including the basement, the total area of the facility is approximately 2,473 square feet. The main level includes:

- Lobby, and secured visitor center
- Men's and women's restrooms
- Storage area with access stairs to basement

Building Systems include:

- Heating and cooling including split system gas heating and electric cooling units
- Ventilation is exhaust with make-up air
- Power is three phase, 120/240 volt, 225 amp

Figure 1 shows the layout of the Homestead Rest Area facility including the rest area's location in relation to major roadways in the area.



Figure 1. Homestead Rest Area Site Layout



B. Field Visit Observations

A field meeting was held with TSP and SDDOT officials on September 17, 2013 to gain initial insights from the SDDOT maintenance team about the operation, history, and condition of the existing on-site facilities. A copy of the meeting minutes are contained in **Appendix A** of this report, and the following summarizes the key points of the meeting:

- The facility was designed and constructed in 1977. There have not been major alterations to the facilities since the construction.
- SDDOT staff estimate the visitor's center and the parking lots are appropriately sized for the current use/demand. Note the following:
 - The maneuvering area for truck parking is limited and should be reviewed.
 - The structure provides limited interior circulation space for the restrooms and visitor's area.
 - The restrooms comfortably support between three to four people at a time.
 - The picnic shelters are used regularly during the summer months (June – August) and estimate only half are used at any one time.
- The dumping station was used regularly by the public, when opened. The facility required closure due to excessive trash being dumped which routinely clogged the system. Alternative low maintenance solutions should be reviewed (refer to Tilford West report).
- The facility includes an insulated ceiling, masonry exterior walls, and glass windows. The insulation suggests the facility was designed for year round use.
- ADA requirements have not been addressed. Major compliance issues include reworking the lobby entrances, and updating toilet rooms with appropriate sinks and five foot stalls.

C. User Environment

The rest area requires users exiting Interstate 29 at SD50 to access the facility. Within the rest area, vehicles are served by a $\frac{3}{4}$ mile single direction access road around the quiet and landscaped site.

The facility was designed by Ward Whitwam, AIA a prominent State of SD Architect, as a somewhat rustic modern facility. Architecturally, the stone faced visitor center and picnic structures are inviting. The facility is modern looking with stone ends near the toilet rooms, and includes a large hipped roof with a glassed in/transparent lobby. The roof originally appears to have been built up, and now looks out of place with the updated white single-ply membrane roof. The interior spaces are inviting, noticeably worn, and in need of better ventilation, lighting, and general refurbishment.

The lodge pole teepee structure can be seen from I-29, originally intended to attract visitors to the rest area. The structure is not an organizing element on the site, nor is anything more provided concerning a further message or function associated with South Dakota history.



D. Existing Building Code Conformity

The current facilities were designed and constructed in 1979 to the codes at the time, which lacked consideration for people with disabilities. To quantify the differences in code standards, the existing main building was evaluated per the ICC 2012 International Building Code which has been adopted by the State of South Dakota. Based on the use of the existing facility, the following building classifications were utilized in the comparison:

- Size: 1,773 square feet
- Occupant Type: Mercantile
- Construction Type: Type 5-b (or 3-b)
- Occupant Load: < 50
- Maximum access travel: 75 feet
- Required Exits: 1

The following outline the major areas where the existing building deviates from the requirements of the current Building Code (IBC 2012):

- GFI power outlets are not present in restrooms, and the information desk requires additional power outlet boxes.
- Facility does not include a family / assisted-use restroom.
- Several areas are not ADA compliant per ICC A117.1-2009 (outlined in following sections).

It should be noted that per the “Existing” Building Code, unless there are significant safety hazards, the facilities are not required to be modernized as a whole to meet current code standards. However, any repairs or new additions will need to be completed to these standards. The exception concerns ADA requirements, which are a retroactive federal requirement. When the ADA is addressed the project will need to also be completed per building code, which includes accessibility criteria (ICC- A117.1-2009).

E. Americans with Disabilities Act (ADA) Survey

As stated previously, the building was originally constructed prior to the ADA and does not meet these requirements. To quantify the improvements required to the current facility for compliance with ADA standards, a detailed survey was completed utilizing the “ADA Checklist for Readily Achievable Barrier Removal” per the DOJ ADA Standards for Accessible Design - 2010. The survey identified the following general deficiencies, and more detailed information is referenced in **Appendix B** of this report:



Priority 1 Deficiencies (access to building):

- Accessible parking spaces at the front of the building are within maximum allowable slope limitations
- The accessible ramp adjacent to the accessible spaces is on a 1:10.9 slope (1:12 is the maximum allowable). The slab adjacent to the front door of the building has been built up with a currently slope of 6.2%
- Curb ramps are not provided at accessible spaces
- Parking signs do not meet current MUTCD standards and the Van Accessible space is not indicated. The accessible parking striping is not in accordance with current standards (11' space and 5' aisle)
- ADA pull handle on entrance door has insufficient clearance
- Door closer takes less than 5 seconds to close from and open position

Priority 2 Deficiencies (Access to Goods and Services):

- Doorways from the lobby to each of the restrooms do not have sufficient corridor width. There is insufficient ADA clearance with the existing 44" wide corridor when using operable restroom entrance doors (46-52" min. required depending upon configuration)
- Information Area
 - Area behind counter and information desks / map counter height does not meet ADA clearance or height standards
 - There is not a section of front counter that is no higher than 36 inches above the floor
 - Signage, upgrade existing signs to current ADA standards

Priority 3 (Restrooms):

- Stall doors not self-closing
- The sign on the wall, located on the push side of the door does not meet ADA standards
- There is not adequate clearance on the pull side of the doors
- Door hardware is not located in compliance with ADA standards
- Entrance doors cannot be opened with 5 lbs. or less of force
- Entrance doors do not take more than 5 seconds to close from an open position
- Pipes below the lavatories are not insulated or covered
- Soap dispensers above the lavatory counter are more than 44 inches above the floor
- Men's and women's toilet is more than 18 inches from the side wall or partition
- Men's and women's toilet does not have adequate clearance to meet ADA standards
- Grab bars do not meet ADA standards
- Toilet paper holders in men's and women's stalls do not meet standards
- Entrance doors to stalls do not meet closure pressure or ADA pull handle standards
- Toilet compartment is less than 60 inches wide



The Interstate Rest Areas Study: Along the I-29 and I-90 Corridors

Priority 4 (additional access) Deficiencies:

- Phone is wall mounted and does not meet ADA standards for sound control, TTY plug in, and shelf.
- Bottom leading edge of the electric water cooler is less than 27 inches above the floor and protrudes more than 4 inches into the circulation path.

F. Energy and Water Usage Review

TSP has not received any data concerning this information:



III. BUILDING SYSTEM OVERVIEW

The following sections include a general review of individual building and site components, starting with site components and then broken down by individual disciplines (Architectural Systems, Mechanical, Electrical, Plumbing, and Civil/Site systems). The discussion generally parallels SDDOT AuditMate database format.

A detailed summary of each discipline section in the current AuditMate format including general comments of individual line items are contained in **Appendix C** of this report. The table contains both existing line items and recommended updates to the SDDOT database, which are shown in **bold** font.

A. *Architectural System*

The building structure includes exterior and interior bearing walls of reinforced masonry and stone. The interior and exterior stone walls are in excellent condition and require cleaning and minor repairs. The roof is a framed hipped type running the long axis and includes a rubber membrane. There are also small copper roofs that cover the front and rear face of the building on the long sides of the facility. The interior finishes are durable and overall in good shape given their age.

The detached equipment garage is weathered and needs paint and roof repairs.

B. *Plumbing System*

All wall hung water closets, urinals, and lavatory sinks are vitreous china and were installed in 1993. The mop sink is enameled cast iron and was installed in 1980. The lavatory faucets and water closet flush valves are electronic / battery operated. The electric wall hung water cooler which was installed in 1993.

Underground or concealed waste and vent piping is cast iron and installed in 1979. Exposed waste and vent piping is PVC plastic and also installed in 1979. Water piping insulation is a mix of original fabric covering or partially closed cell foam insulation.

Water for domestic use is supplied by a rural water system. The system has a water pressure regulator, water meter, backflow preventer, pressure booster system and a 6000 gallon underground fiberglass holding tank. Water is pumped from the storage tank to all plumbing fixtures in the building. The water system that supplies the domestic water supply system was installed 1992 and some of the components may have been replaced over time. The lawn irrigation system, installed in 1979, also draws water from the holding tank and has a separate water pressure booster system.

C. *Mechanical System*

The building is heated and cooled by (2) split-system air-to-air heat pumps installed in 2000. Electric unit heaters, installed in 1979 in the equipment / storage rooms provide heating to those rooms. There are outside air duct connections to both systems for ventilation.



Exhaust ventilation for each of the toilet rooms is ducted to small utility fan set. Exhaust grilles are wall mounted on the water closet wall in each toilet room. There is also a utility fan set for exhaust ventilation of the basement equipment room. This system, installed in 1979, was not operable at the time of the inspection.

D. Electrical System

The building is served by a 120/208 volt, 3 phase, 200 amp service. There are two circuit breaker panels located the main floor equipment room. Panels are clearly labeled as to what each breaker serves. All wiring is run in conduit and panel boards appeared to be original equipment, installed in 1997.

Lighting fixtures in the building are a mix of recessed and surface mounted type, and were installed in 1979. All lamps in the fixtures have been changed to fluorescent.

Outdoor lighting is primarily high pressure sodium or HID. Recessed and surface mounted fixtures are used on the building. Some fixtures have signs of moisture inside the lens, indicating the lens no longer seals properly. Most outdoor lighting has been in service since 1979.

Hand dryers are electric and operating properly.

CCTV is installed in the lobby. There is also an emergency beacon system, the operation of which was not immediately observable, but confirmed by staff.

Telephone and internet services are installed in the building.

E. Sanitary Sewer System

The sanitary sewer system consists of gravity flow sewer lines to two sewage lagoons located at the south end of the site. A lift station is used to pump water into the lagoons. The north lagoon is approximately twice as large as the south lagoon.

According to maintenance personnel, the ponds provide adequate capacity. The only problem mentioned was occasional clogging that is cleared at the last manhole or at the pump in that manhole. There have been no problems with the pipes upstream of that manhole.

When in operation, the pipes from the dump station clogged frequently. The chronic clogging issue led to the closing of the dump station, and there are no plans to re-open the facility in the future.

F. Water System

The water for the site is supplied by Clay Rural Water. A steel underground tank is used for storage and a pump is used to pressurize the system. There has been no problem with this system outside of the building.



G. Infrastructure

The parking area is all concrete. The general condition of the concrete for the ramps and the parking area is good, with observed deterioration being in the joints. There is extreme cracking in the southeast corner of the lot near the sewage lagoons, and is confirmed by the latest paving ratings done by the SDDOT. In these ratings, joint seals are the lowest rated followed by joint spalling. The ratings also indicate some punchout damage in the long entrance ramp which may reflect the extreme cracking mentioned above, and will need to be replaced in the near future. Joint repair and sealing should continue to be done to extend the life of the pavement.

Maintenance personnel stated that the slope where the exit ramp meets SD50 can be too steep for icy conditions. In addition, trucks are running over the curb and gutter as they turn west onto highway SD50. Staff also mentioned that the parking area may not be wide enough for trucks to turn into the marked parking spaces. Re-stripping the parking spaces should be reviewed.

Concrete walk extends along the parking spaces, around the building and to picnic shelters located around the site. The majority of the concrete sidewalk is in good shape. Approximately 20% of the sidewalk has cracks that may require replacement in the future. The cracked sidewalk is located around the building and in the area of the teepee sculpture.



IV. SUMMARY

The Homestead Rest Area is located aside northbound Interstate 29, off of highway SD50, in the southeast corner of the State of SD. The site is approximately 50 miles south of Sioux Falls and 7 miles east of Vermillion, SD, on route SD50. The facility is unique as it is not directly accessible from Interstate 29 but from highway SD50 connecting west to Vermillion. As such, the facility services northbound and southbound Interstate 29 and SD50 traffic.

The purpose of this report was to summarize the condition of existing site components and building systems for the facility as a whole, and to define the general status of the existing facilities given their age and use.

It is our understanding the facility services a high percentage of local travelers, and tourists coming from or through Iowa and Nebraska, as well as truckers. The site is substantial and there is adequate space for expansion in the future. The site as a whole is in fair condition and will require repairs and improvements to certain systems (lighting, sidewalks, sprinkler, etc.).

The site and facility meets current needs. The facility is architecturally attractive but is weathered and worn. The main building structure was built in 1979 and is reaching its design life. General refurbishment of some mechanical, plumbing and electrical systems would be required moving forward.

The facility will need to be modified to comply with ADA/building code requirements. The extent of which has yet to be determined, as an additional factor will be in identifying the added space required to modify the restroom entrances, to support increased user loads (if any), and to provide family assist restroom(s).



The Interstate Rest Areas Study: Along the I-29 and I-90 Corridors

APPENDIX A MAINTENANCE STAFF MEETING MINUTES



October 15, 2013

MEETING MINUTES

SDDOT INTERSTATE REST AREA STUDY

FHU Reference No. 113039-01

Homestead Maintenance Review Meeting
Homestead Rest Area

Date of Meeting: September 17, 2013

In attendance:

- Brad Remmich – SDDOT
- Jerry Hanson – SDDOT
- Jeff Gustafson - SDDOT
- Tim Roach – TSP
- Bob King – TSP
- Todd Schultz - TSP

The purpose of the meeting was to gain initial insights from the SDDOT maintenance team about the operation, history, and condition of the existing on-site facilities at the Homestead rest area. The following summarizes the key points of the meeting:

FACILITY USE

- There is a consistent year round use of the facilities by truckers, and local commuters, however in the summer months the highest amount of use is by tourists. The site is shared with a separate small state police building (which is outside the scope of this review).
- The site is unique as it is not directly accessed from the highway. One must exit the highway to an intersection, and proceed to an entrance. This makes the site accessible to/from the highway from both north and south directions. This added step/distance does not seem to impact travelers/truckers according to the maintenance team. It is nice having one larger facility to maintain rather than two.
- Per the SDDOT, at this time the visitor's center facility seems to be appropriately sized for the current use as does truck and auto parking.
- There is a visitor's area within the facility which is manned in the summer months – it is somewhat larger than most in the state. The work area is separated from the lobby (where exhibits are placed) by a wall and information counter with a rolling door. The lobby is not designed for floor displays which clutter up the area.
- Adjacent from the information areas is a large shared storage /equipment/mechanical room, and a partial 700sf basement (under the storage and men's restroom) which are also used for lawn equipment and brochure storage, etc.
- On site there is a garage structure which is used for equipment storage and some tourist information brochure storage as well.

- The structure itself seems to be limited in interior circulation space for both the restrooms and the visitor's area. The restrooms comfortably support perhaps 3-4 people at a time, but there is little maneuvering space.
- The picnic shelters are used regularly during the summer months (June – August) but we understand are never more than ½ used.
- The dumping station was fairly often used, more by locals, until closed off – apparently much trash is dumped in clogging and shutting down the system. Alternative solutions are needed.

USER INFORMATION

- There are a higher proportion of general travelers and truckers at this location. Truckers do overnight at this location. A lot of local travelers use this facility.

FACILITY NEEDS / ISSUES

- There have been some consistent comments from travelers at this location which include:
 - Poor lighting in restrooms.
 - Visitor Center – poor ventilation and heat.
 - Plumbing Fixtures non- functioning often
- There is no immediate safety issues reported. A video monitor system is very successful in reducing vandalism and security problems.
- There is no history of accidents related to current facility and on site circulation.
- Truck maneuvering is a bit tight from parking stalls.
- Site Systems (landscaping, lighting, trash, ponds, etc.):
 - Sidewalk and paving maintenance repairs needed but otherwise surfaces are in good condition.
 - Lagoon System was re-lined in 1998. Could use re-lining and riprap soon. Capacity is adequate with 2 ponds; the north pond is approximately twice the size of the south pond. Piping system consists of manholes with a pump at the last manhole. They have had some problems with the manhole and the pump clogging in the past. Dump Station was removed due to pipe clogging problems. The staff really doesn't want to replace it.
 - Water supply is from Clay Rural Water. There is a steel underground tank. System has had no problems at this time.
 - The lawn sprinkler system will need replacement.
 - Site parking, pedestrian, and exterior building lighting systems are original and are becoming unruly and expensive to maintain.
 - Site drainage is adequate, and there isn't a history of ponding or flooding. Downspout system could use repair or replacement as it does not drain well at the front of the building. This may cause some walk cracking.
 - Dog walk area has heavy use, could use baggie stand to assist and encourage user pick up and disposal of dog waste.
- Building Systems (shell, interior finishes, MEP):
 - Upgrade to ADA.
 - Replace video camera system.

October 15, 2013

Homestead Maintenance Review Meeting

Page 3

- Replace aged plumbing fixture valves/sensors.
- Membrane roof system on main building is 10yr warranty, and will need replacement.
- Picnic shelters need some repairs & refurbishing. They are dark, a little musty, and several have standing water.
- Heat, cooling, and Ventilation system replacement/modernization is past due.
- Electrical power upgrades in support of the visitor station desk are needed.
- Interior Lighting outdated and failing – maintenance cost and problems...needs replacement.
- Bathroom exhaust fans should be replaced, due to age/condition.
- Basement exhaust fan is not operational and should be replaced.
- Domestic water pressure booster system is leaking and should be replaced.
- Heating, cooling, and ventilation are marginal at best at this facility.
- Domestic water heater should be replaced, due to age/condition.
- Portable dehumidifier in basement should be replaced, due to age/condition

SDDOT MAINTENANCE STAFF REQUESTS

- Small size and old age of facility are limiting factors.

These meeting minutes were prepared by Tim Roach (TSP). Please contact me at roachtj@teamtsp.com or 605-343-6102 for corrections or clarifications.



The Interstate Rest Areas Study: Along the I-29 and I-90 Corridors

APPENDIX B ADA SURVEY RESULTS

SDDOT Rest Area Improvements
FHU Reference Number 13-039-01
TSP Project Number 03120855

Building **HOMESTEAD**

Location **29 N/S., MRM 26**

Date **09-17-2013 (Inspection)**

ADA Checklist for Readily Achievable Barrier Removal

Priority 1 – Approach & Entrance



SDDOT Rest Area Improvements

FHU Reference Number 13-039-01

TSP Project Number 03120855

Project

Building

HOMESTEAD

Location

29 N/S., MRM 26

Date

09-17-2013 (Inspection)

Surveyors

Timothy Roach, AIA

Todd Schultz, PE

Robert King, CPD

Contact Information **TSP (605) 343-6102**

An accessible route from site arrival points and an accessible entrance should be provided for everyone.



Institute for Human Centered Design
www.HumanCenteredDesign.org

November 2011



ADA National Network

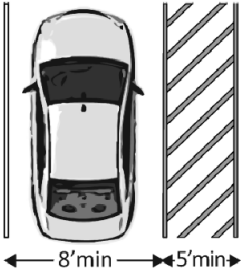
Questions on the ADA 800-949-4232 voice/tty

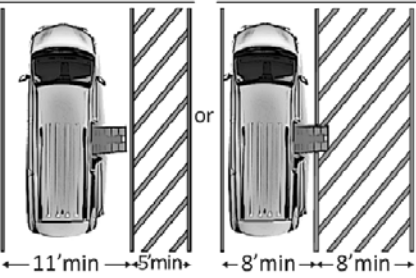
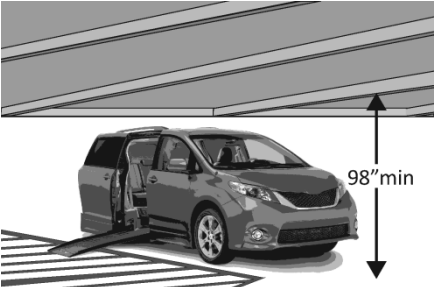
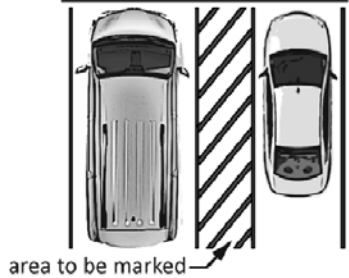
www.ADAchecklist.org


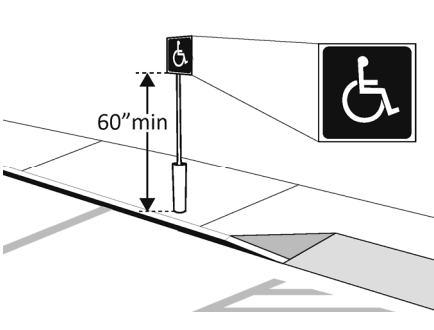
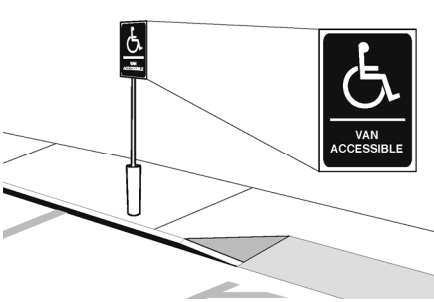
This checklist was produced by the New England ADA Center, a project of the Institute for Human Centered Design and a member of the ADA National Network. This checklist was developed under a grant from the Department of Education, NIDRR grant number H133A060092-09A. However the contents do not necessarily represent the policy of the Department of Education, and you should not assume endorsement by the Federal Government.

Questions or comments on the checklist contact the New England ADA Center at 617-695-0085 voice/tty or ADAinfo@NewEnglandADA.org

For the full set of checklists, including the checklists for recreation facilities visit www.ADAchecklist.org.

Priority 1 – Approach & Entrance		Comments	Possible Solutions												
<p>1.1 Is there at least one route from site arrival points (parking, passenger loading zones, public sidewalks and public transportation stops) that does not require the use of stairs?</p>	<p><input checked="" type="checkbox"/> Yes <input type="checkbox"/> No</p> <p>If yes, location of route:</p>	<p>Photo #: 1.1</p>	<ul style="list-style-type: none"> • Add a ramp • Regrade to 1:20 maximum slope • Add a lift if site constraints prevent other solutions 												
<p>Parking (2010 Standards – 208 & 502) Note: Accessible parking spaces should be identified by size, access aisle and signage.</p>															
<p>1.2 If parking is provided for the public, are an adequate number of accessible spaces provided?</p>	<p><input checked="" type="checkbox"/> Yes <input type="checkbox"/> No</p> <p>Total #: 38</p> <p>Accessible #: 2</p>	<table border="1"> <thead> <tr> <th>Total Spaces</th> <th>Accessible Spaces</th> </tr> </thead> <tbody> <tr> <td>1 - 25</td> <td>1</td> </tr> <tr> <td>26 - 50</td> <td>2</td> </tr> <tr> <td>51 - 75</td> <td>3</td> </tr> <tr> <td>76 - 100</td> <td>4</td> </tr> <tr> <td colspan="2">100+ see 2010 Standards 208.2</td> </tr> </tbody> </table> <p>Photo #: 1.2</p>	Total Spaces	Accessible Spaces	1 - 25	1	26 - 50	2	51 - 75	3	76 - 100	4	100+ see 2010 Standards 208.2		<ul style="list-style-type: none"> • Reconfigure by repainting lines • •
Total Spaces	Accessible Spaces														
1 - 25	1														
26 - 50	2														
51 - 75	3														
76 - 100	4														
100+ see 2010 Standards 208.2															
<p>1.3 Of the accessible spaces, is at least one a van accessible space?*</p>	<p><input type="checkbox"/> Yes <input checked="" type="checkbox"/> No</p>	<p>*For every 6 or fraction of 6 parking spaces required by the table above, at least 1 should be a van accessible space.</p> <p>NEEDS TO BE SIGNED AS VAN ACCESSIBLE. RESTRIPE SO 8' X 8' SPACE/ACCESS AISLE</p> <p>Photo #: 1.3</p>	<p>* If constructed before 3/15/2012, parking is compliant if at least 1 in every 8 accessible spaces is van accessible</p> <ul style="list-style-type: none"> • Reconfigure by repainting lines 												
<p>1.4 Are accessible spaces at least 8 feet wide with an access aisle at least 5 feet wide?</p>	<p><input checked="" type="checkbox"/> Yes <input type="checkbox"/> No</p> <p>Measurement: 10 FT SPACE 6 FT AISLE</p>	 <p>Photo #: 1.4</p>	<ul style="list-style-type: none"> • Reconfigure by repainting lines <p>Two spaces can share an access aisle (check state requirements; some states, such as Connecticut, require an access aisle for</p>												

<p>1.5 Is the van accessible space: At least 11 feet wide with an access aisle at least 5 feet wide? Or At least 8 feet wide with an access aisle at least 8 feet wide?</p>	<p><input type="checkbox"/> Yes <input checked="" type="checkbox"/> No Measurement:</p> <p><input type="checkbox"/> Yes <input checked="" type="checkbox"/> No Measurement: 10' SPACE 6' AISLE</p>		<p>Photo #: 1.5</p>	<p>each space)</p> <ul style="list-style-type: none"> • Reconfigure to provide van-accessible space(s) • •
<p>1.6 Is at least 98 inches of vertical clearance provided for the van accessible space?</p>	<p><input type="checkbox"/> Yes <input type="checkbox"/> No Measurement:</p>		<p>Photo #: NA</p>	<ul style="list-style-type: none"> • Reconfigure to provide van-accessible space(s) • •
<p>1.7 Are the access aisles marked so as to discourage parking in them?</p>	<p><input checked="" type="checkbox"/> Yes <input type="checkbox"/> No</p>		<p>Photo #: 1.1</p>	<ul style="list-style-type: none"> • Mark access aisles • • <p>The marking method and color may be addressed by state/local requirements</p>
<p>1.8 Is the slope of the accessible parking spaces and access aisles no steeper than 1:48 in all directions?</p>	<p><input checked="" type="checkbox"/> Yes <input type="checkbox"/> No Measurement: <2%</p>		<p>Photo #:</p>	<ul style="list-style-type: none"> • Regrade surface • •

<p>1.9 Do the access aisles adjoin an accessible route?</p>	<p><input checked="" type="checkbox"/> Yes <input type="checkbox"/> No</p>		<p>Photo #: 1.1</p>	<ul style="list-style-type: none"> • Create accessible route • Relocate accessible space •
<p>1.10 Are accessible spaces Identified with a sign that includes the International Symbol of Accessibility?</p> <p>Is the bottom of the sign at least 60 inches above the ground?</p>	<p><input checked="" type="checkbox"/> Yes <input type="checkbox"/> No</p> <p><input checked="" type="checkbox"/> Yes <input type="checkbox"/> No</p> <p>Measurement: 88"</p>		<p>Photo #: 1.10</p>	<ul style="list-style-type: none"> • Install signs • • <p>The International Symbol of Accessibility is not required on the ground by the 2010 Standards</p>
<p>1.11 Are there signs reading “van accessible” at van accessible spaces?</p>	<p><input type="checkbox"/> Yes <input checked="" type="checkbox"/> No</p>		<p>NA</p> <p>Photo #:</p>	<ul style="list-style-type: none"> • Install signs • •
<p>1.12 Of the total parking spaces, are the accessible spaces located on the closest accessible route to the accessible entrance(s)?</p>	<p><input checked="" type="checkbox"/> Yes <input type="checkbox"/> No</p>		<p>Photo #: 1.1</p>	<ul style="list-style-type: none"> • Reconfigure spaces • • If parking lot serves multiple entrances, accessible parking should be dispersed

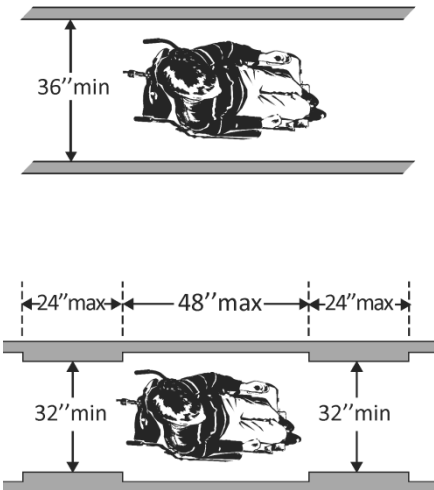
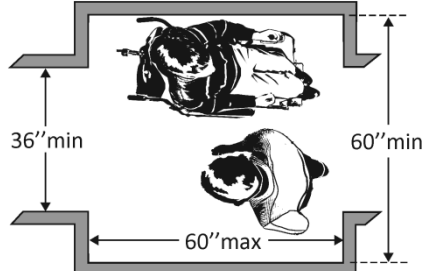
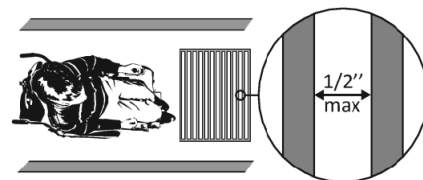
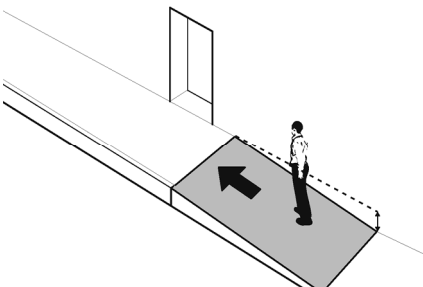
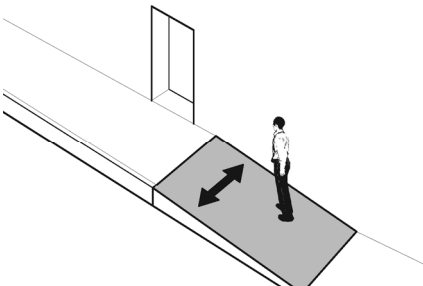
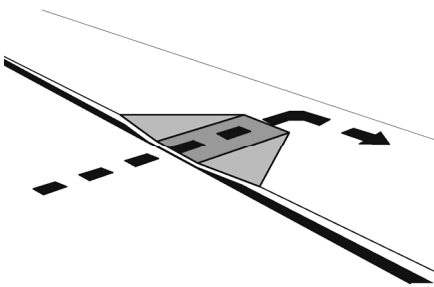
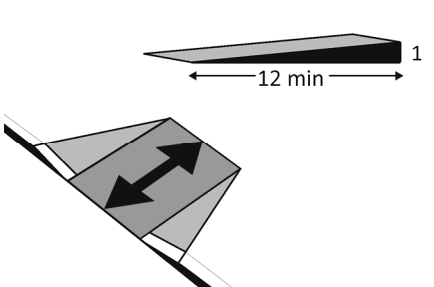
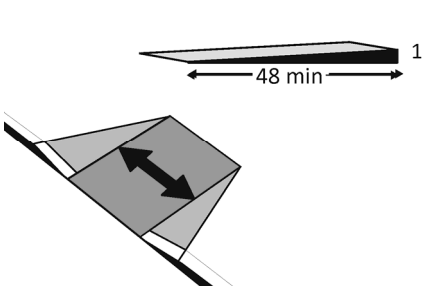
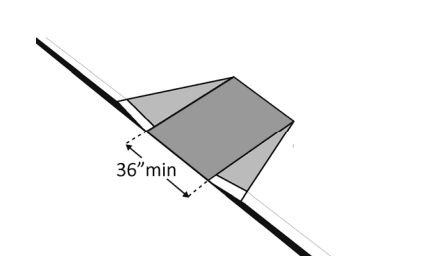
Exterior Accessible Route (2010 Standards – Ch.4)				
<p>1.13 Is the route stable, firm and slip-resistant?</p>	<p><input checked="" type="checkbox"/> Yes <input type="checkbox"/> No</p>		<p>Photo #: 1.13</p>	<ul style="list-style-type: none"> • Repair uneven paving • Fill small bumps and breaks with patches • Replace gravel with asphalt or other surface
<p>1.14 Is the route at least 36 inches wide?</p> <p>Note: The accessible route can narrow to 32 inches min. for a max. of 24 inches. These narrower portions of the route must be at least 48 inches from each other.</p>	<p><input checked="" type="checkbox"/> Yes <input type="checkbox"/> No</p> <p>Measurement: 108"</p>		<p>Photo 1.1</p>	<ul style="list-style-type: none"> • Change or move landscaping, furnishings or other items • Widen route •
<p>1.15 If the route is greater than 200 feet in length and no less than 60 inches wide, is there a passing space no less than 60 x 60 inches?</p>	<p><input type="checkbox"/> Yes <input type="checkbox"/> No</p> <p>Measurement: NA</p>		<p>NA</p>	<ul style="list-style-type: none"> • Widen route for passing space • •

			Photo #:	
<p>1.16 If there are grates or openings on the route, are the openings no larger than ½ inches to the dominant direction of travel?</p> <p>Is the long dimension perpendicular to the dominant direction of travel?</p>	<p><input type="checkbox"/> Yes <input type="checkbox"/> No</p> <p>Measurement:</p> <p><input type="checkbox"/> Yes <input type="checkbox"/> No</p> <p>NA</p>		Photo #:	<ul style="list-style-type: none"> • Replace or move grate • •
<p>1.17 Is the running slope no steeper than 1:20, i.e. for every inch of height change there are at least 20 inches of route run?</p>	<p><input checked="" type="checkbox"/> Yes <input type="checkbox"/> No</p> <p>Measurement:</p> <p>6.7% AT DOOR</p>		Photo #:	<ul style="list-style-type: none"> • Regrade to 1:20 max. • If steeper than 1:20 and no steeper than 1:12, treat as a ramp and add other features such as edge protection and handrails •
<p>1.18 Is the cross slope no steeper than 1:48?</p>	<p><input checked="" type="checkbox"/> Yes <input type="checkbox"/> No</p> <p>Measurement:</p> <p><2%</p>		Photo #:	<ul style="list-style-type: none"> • Regrade to 1:48 max. • •

Curb Ramps (2010 Standards – 406)

<p>1.19 If the accessible route crosses a curb, is there a curb ramp?</p>	<p><input checked="" type="checkbox"/> Yes <input type="checkbox"/> No</p>		<p>Photo #: 1.2</p>	<ul style="list-style-type: none"> • Install curb ramp • •
<p>1.20 Is the running slope of the curb ramp no steeper than 1:12, i.e. for every inch of height change there are at least 12 inches of curb ramp run?</p>	<p><input type="checkbox"/> Yes <input checked="" type="checkbox"/> No</p> <p>Measurement: 1:10.9 (9.2%)</p>		<p>Photo #: 0025</p>	<ul style="list-style-type: none"> • Regrade curb ramp • •
<p>1.21 Is the cross slope of the curb ramp, excluding flares, no steeper than 1:48?</p>	<p><input checked="" type="checkbox"/> Yes <input type="checkbox"/> No</p> <p>Measurement: NA</p>		<p>Photo #: 0027 & 0028</p>	<ul style="list-style-type: none"> • Regrade curb ramp • •
<p>1.22 Is the curb ramp, excluding flares, at least 36 inches wide?</p>	<p><input checked="" type="checkbox"/> Yes <input type="checkbox"/> No</p> <p>Measurement:</p>		<p>Photo #: 0027</p>	<ul style="list-style-type: none"> • Widen curb ramp • •

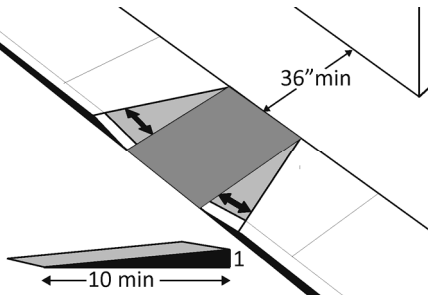
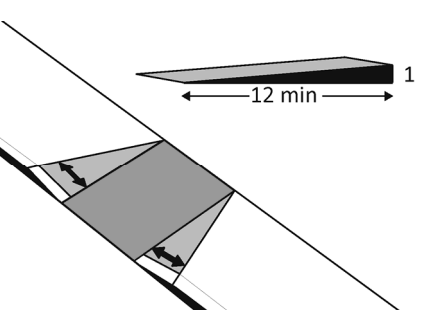
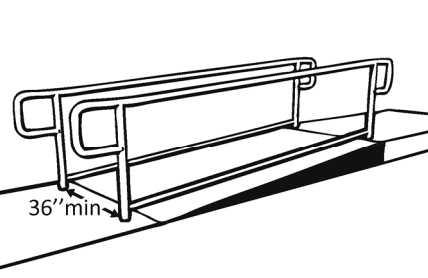
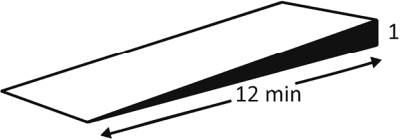
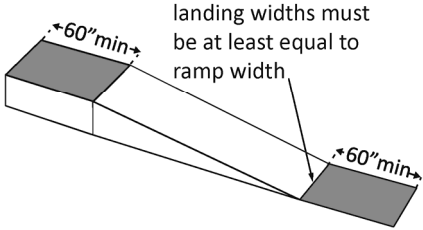
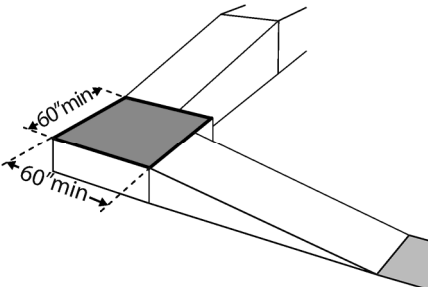
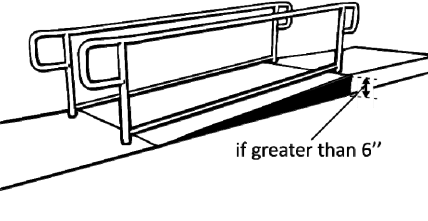
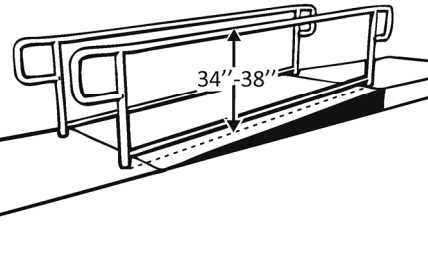
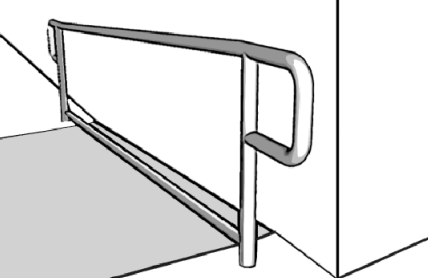
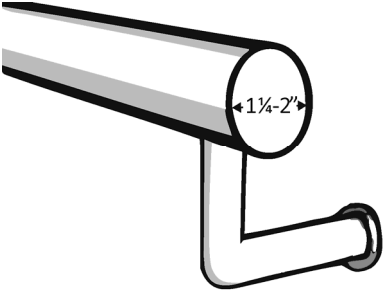
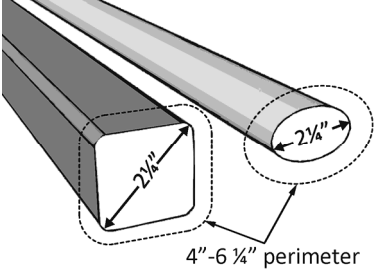
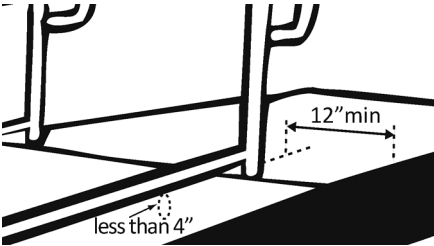
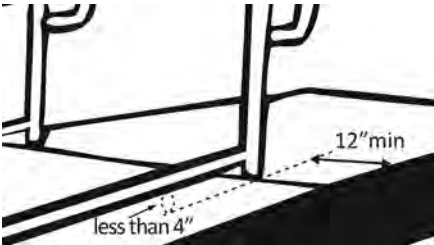



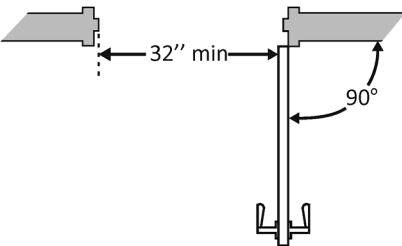
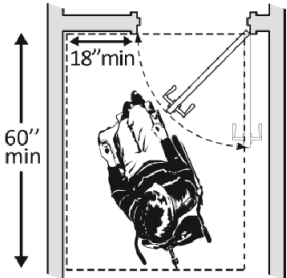
<p>1.23 At the top of the curb ramp is there a level landing (slope no steeper than 1:48 in all directions) that is at least 36 inches long and at least as wide as the curb ramp? If there are curb ramp flares, are the slopes of the flares no steeper than 1:10, i.e. for every inch of height change there are at least 10 inches of flare run?</p>	<p><input checked="" type="checkbox"/> Yes <input type="checkbox"/> No Measurement:</p> <p><input checked="" type="checkbox"/> Yes <input type="checkbox"/> No Measurement:</p>		<p>Photo #: 0027</p>	<ul style="list-style-type: none"> • Reconfigure • Add ramp flares •
<p>1.24 If the landing at the top is less than 36 inches long, are there curb ramp flares? Are the slopes of the flares no greater than 1:12, i.e. for every inch of height change there are at least 12 inches of flare run?</p>	<p><input type="checkbox"/> Yes <input type="checkbox"/> No Measurement:</p> <p><input type="checkbox"/> Yes <input type="checkbox"/> No Measurement:</p>		<p>Photo #: NA</p>	<ul style="list-style-type: none"> • Add ramp flares • Regrade flares •
<p>Ramps (2010 Standards – 405 & 505) Note: If any portion of the accessible route is steeper than 1:20, it should be treated as a ramp.</p>				
<p>1.25 If there is a ramp (other than curb ramps), is it at least 36 inches wide? If there are handrails, measure between the handrails.</p>	<p><input type="checkbox"/> Yes <input type="checkbox"/> No Measurement:</p> <p>NA</p>		<p>Photo #: NA</p>	<ul style="list-style-type: none"> • Alter ramp • •
<p>1.26 Is the surface stable, firm and slip resistant?</p>	<p><input type="checkbox"/> Yes <input type="checkbox"/> No NA</p>		<p>NA</p>	<ul style="list-style-type: none"> • Resurface ramp • •

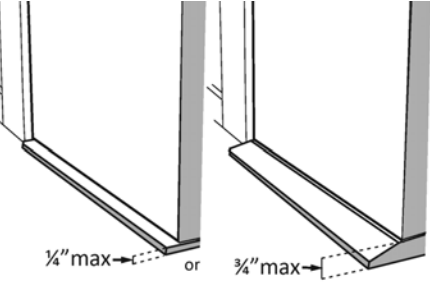
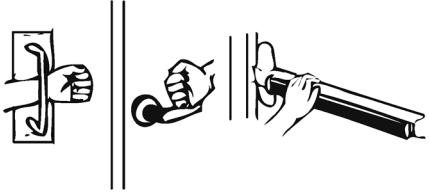
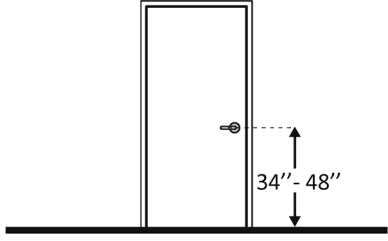
			Photo #:	
<p>1.27 For each section of the ramp, is the running slope no greater than 1:12, i.e. for every inch of height change there are at least 12 inches of ramp run? Note: Rises no greater than 3 inches with a slope no steeper than 1:8 and rises no greater than 6 inches with a slope no steeper than 1:10 are permitted when such slopes are necessary due to space limitations.</p>	<p><input type="checkbox"/> Yes <input type="checkbox"/> No Measurement: NA</p>		<p>NA</p> <p>Photo #:</p>	<ul style="list-style-type: none"> • Alter or relocate ramp • Lengthen ramp to decrease slope •
<p>1.28 Is there a level landing that is at least 60 inches long and at least as wide as the ramp: At the top of the ramp? At the bottom of the ramp?</p>	<p><input type="checkbox"/> Yes <input type="checkbox"/> No Measurement: <input type="checkbox"/> Yes <input type="checkbox"/> No Measurement:</p>		<p>NA</p> <p>Photo #:</p>	<ul style="list-style-type: none"> • Alter ramp • •

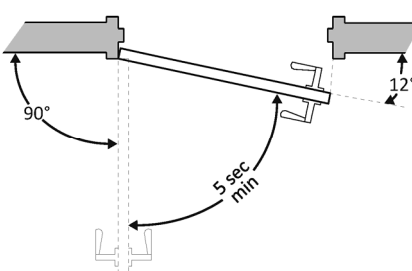
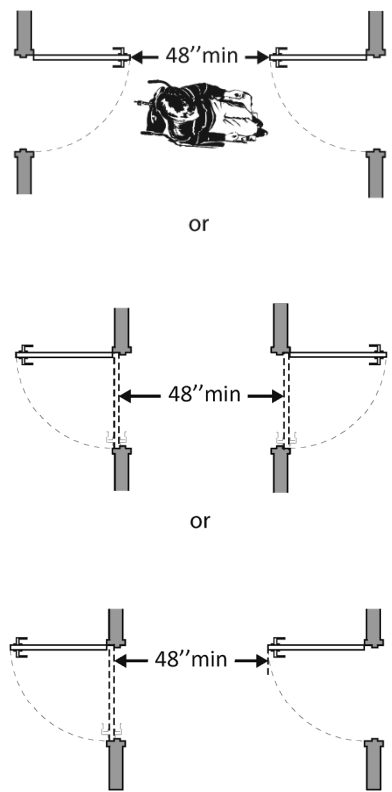
<p>1.29 Is there a level landing where the ramp changes direction that is at least 60 x 60 inches?</p>	<p><input type="checkbox"/> Yes <input type="checkbox"/> No</p> <p>Measurement:</p>	 <p>A perspective diagram of a ramp with a rectangular landing area. Dashed lines and arrows indicate the landing is at least 60 inches wide and 60 inches deep.</p>	<p style="text-align: center;">NA</p> <p>Photo #:</p>	<ul style="list-style-type: none"> • Alter ramp • •
<p>1.30 If the ramp has a rise higher than 6 inches, are there handrails on both sides?</p>	<p><input type="checkbox"/> Yes <input type="checkbox"/> No</p> <p>Measurement:</p>	 <p>A perspective diagram of a ramp with handrails on both sides. A note below the ramp says "if greater than 6''".</p>	<p style="text-align: center;">NA</p> <p>Photo #:</p>	<ul style="list-style-type: none"> • Add handrails • • <p>Curb ramps are not required to have handrails</p>
<p>1.31 Is the top of the handrail gripping surface no less than 34 inches and no greater than 38 inches above the ramp surface?</p>	<p><input type="checkbox"/> Yes <input type="checkbox"/> No</p> <p>Measurement:</p>	 <p>A perspective diagram of a handrail. A vertical double-headed arrow indicates the height from the ramp surface to the top of the gripping surface is 34"-38".</p>	<p style="text-align: center;">NA</p> <p>Photo #:</p>	<ul style="list-style-type: none"> • Reconfigure or replace handrails • •
<p>1.32 Is the handrail gripping surface continuous and not obstructed along the top or sides?</p> <p>Is the bottom of the handrail gripping surface obstructed for no more than 20 percent of its length?</p>	<p><input type="checkbox"/> Yes <input type="checkbox"/> No</p> <p><input type="checkbox"/> Yes <input type="checkbox"/> No</p> <p>Measurement:</p>	 <p>A perspective diagram of a handrail. The bottom of the handrail is shown with a gap where it meets the ramp surface, illustrating an obstruction.</p>	<p style="text-align: center;">NA</p> <p>Photo #:</p>	<ul style="list-style-type: none"> • Reconfigure or replace handrails • •


<p>1.33 If the handrail gripping surface is circular, is it no less than 1 ¼ inches and no greater than 2 inches in diameter?</p>	<p><input type="checkbox"/> Yes <input type="checkbox"/> No</p> <p>Measurement:</p>		<p style="text-align: center;">NA</p> <p>Photo #:</p>	<ul style="list-style-type: none"> • Replace handrails • •
<p>1.34 If the handrail gripping surface is non-circular, is it no less than 4 inches and no greater than 6 ½ inches in perimeter and no more than 2 ¼ inches in cross section?</p>	<p><input type="checkbox"/> Yes <input type="checkbox"/> No</p> <p>Measurement:</p>		<p style="text-align: center;">NA</p> <p>Photo #:</p>	<ul style="list-style-type: none"> • Replace handrails • •
<p>1.35 Does the handrail:</p> <p>Extend at least 12 inches horizontally beyond the top and bottom of the ramp?</p> <p>Return to a wall, guard, or landing surface?</p>	<p><input type="checkbox"/> Yes <input type="checkbox"/> No</p> <p>Measurement:</p> <p><input type="checkbox"/> Yes <input type="checkbox"/> No</p>		<p style="text-align: center;">NA</p> <p>Photo #:</p>	<ul style="list-style-type: none"> • Add extensions • Reconfigure handrails •
<p>1.36 To prevent wheelchair casters and crutch tips from falling off:</p> <p>Does the surface of the ramp extend at least 12 inches beyond the inside face of the handrail?</p> <p>Or</p> <p>Is there a curb or barrier that</p>	<p><input type="checkbox"/> Yes <input type="checkbox"/> No</p> <p>Measurement:</p> <p><input type="checkbox"/> Yes <input type="checkbox"/> No</p>		<p style="text-align: center;">NA</p> <p>Photo #:</p>	<ul style="list-style-type: none"> • Add curb • Add barrier • Extend ramp width •

<p>prevents the passage of a 4-inch diameter sphere?</p>	<p>Measurement:</p>		<p>Photo #:</p>	
<p>Entrance (2010 Standards – 404)</p>				
<p>1.37 Is the main entrance accessible?</p>	<p><input checked="" type="checkbox"/> Yes <input type="checkbox"/> No</p>		<p>Photo #: 1.37</p>	<ul style="list-style-type: none"> • Redesign to make it accessible • •
<p>1.38 If the main entrance is not accessible, is there an alternative accessible entrance?</p> <p>Can the alternative accessible entrance be used independently and during the same hours as the main entrance?</p>	<p><input type="checkbox"/> Yes <input type="checkbox"/> No</p> <p><input type="checkbox"/> Yes <input type="checkbox"/> No</p>		<p>NA</p> <p>Photo #:</p>	<ul style="list-style-type: none"> • Designate an entrance and make it accessible • Ensure that accessible entrance can be used independently and during the same hours as the main entrance •

<p>1.39 Do all inaccessible entrances have signs indicating the location of the nearest accessible entrance?</p>	<p><input type="checkbox"/> Yes <input type="checkbox"/> No</p>		<p style="text-align: center;">NA</p> <p>Photo #:</p>	<ul style="list-style-type: none"> • Install signs • Install signs on route before people get to inaccessible entrances so that people do not have to turn around and retrace route •
<p>1.40 If not all entrances are accessible, is there a sign at the accessible entrance with the International Symbol of Accessibility?</p>	<p><input type="checkbox"/> Yes <input type="checkbox"/> No</p>		<p style="text-align: center;">NA</p> <p>Photo #:</p>	<ul style="list-style-type: none"> • Install sign • •
<p>1.41 Is the clear opening width of the accessible entrance door at least 32 inches, between the face of the door and the stop, when the door is open 90 degrees?</p>	<p><input checked="" type="checkbox"/> Yes <input type="checkbox"/> No</p> <p>Measurement:</p> <p style="text-align: center;">32"</p>		<p>Photo #: 1.41</p>	<ul style="list-style-type: none"> • Alter door • Install offset hinges •
<p>1.42 If there is a front approach to the pull side of the door, is there at least 18 inches of maneuvering clearance beyond the latch side plus at least 60 inches clear depth?</p> <p>On both sides of the door, is the</p>	<p><input checked="" type="checkbox"/> Yes <input type="checkbox"/> No</p> <p>Measurement:</p> <p style="text-align: center;">32"</p> <p><input checked="" type="checkbox"/> Yes <input type="checkbox"/> No</p>		<p>Photo #:</p>	<p>See 2010 Standards 404.2.4 for maneuvering clearance requirements on the push side of the door and side approaches to the pull side of the door</p> <ul style="list-style-type: none"> • Remove obstructions

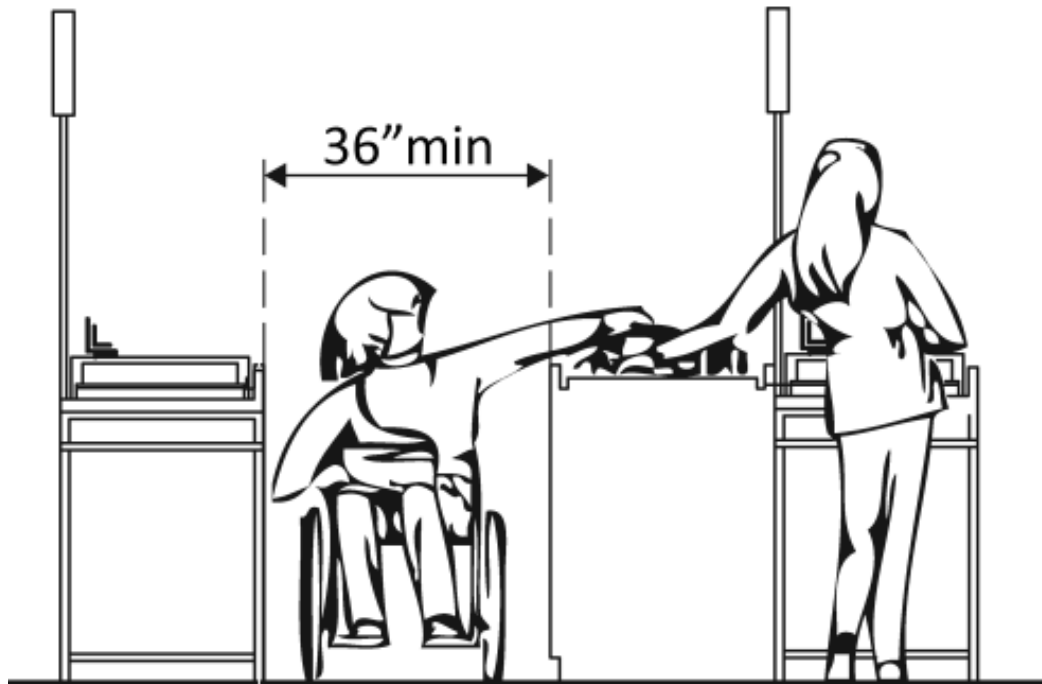
<p>ground or floor surface of the maneuvering clearance level (no steeper than 1:48)?</p>	<p>Measurement:</p>		<p>Photo #: 1.42</p>	<ul style="list-style-type: none"> • Reconfigure walls • Add automatic door opener
<p>1.43 Is the door threshold edge no more than ¼ inch high?</p> <p>Or</p> <p>No more than ¾ inch high if slope is beveled no steeper than 1:2?</p> <p>Note: The first ¼ inch of the threshold may be vertical; the rest must be beveled.</p>	<p><input type="checkbox"/> Yes <input type="checkbox"/> No</p> <p>Measurement: ¾"</p> <p><input checked="" type="checkbox"/> Yes <input type="checkbox"/> No</p> <p>Measurement: ¾"</p>		<p>Photo #: 1.41</p>	<ul style="list-style-type: none"> • Remove or replace threshold • •
<p>1.44 Is the door equipped with hardware, including locks, that is operable with one hand and does not require tight grasping, pinching, or twisting of the wrist?</p>	<p><input type="checkbox"/> Yes <input checked="" type="checkbox"/> No</p>		<p>Photo #: 1.42</p>	<ul style="list-style-type: none"> • Replace inaccessible knob with lever, loop or push hardware • Add automatic door opener •
<p>1.45 Are the operable parts of the door hardware no less than 34 inches and no greater than 48 inches above the floor or ground surface?</p>	<p><input type="checkbox"/> Yes <input type="checkbox"/> No</p> <p>Measurement: 37" BOTTOM 47" TOP</p>		<p>Photo #: 1.45</p>	<ul style="list-style-type: none"> • Change hardware height • •

<p>1.46 If the door has a closer, does it take at least 5 seconds to close from an open position of 90 degrees to a position of 12 degrees from the latch?</p>	<p><input checked="" type="checkbox"/> Yes <input type="checkbox"/> No</p> <p>Measurement: 5 SEC.</p>		<p>Photo #:</p>	<ul style="list-style-type: none"> • Adjust closer • •
<p>1.47 If there are two doors in a series, e.g. vestibule, is the distance between the doors at least 48 inches plus the width of the doors when swinging into the space?</p>	<p><input type="checkbox"/> Yes <input type="checkbox"/> No</p> <p>Measurement:</p>		<p>Photo #:</p> <p style="text-align: center; color: red; font-weight: bold;">NA</p>	<ul style="list-style-type: none"> • Remove inner door • Change door swing •

<p>1.48 If provided at the building entrance, are carpets or mats no higher than ½ inch thick?</p>	<p><input type="checkbox"/> Yes <input type="checkbox"/> No</p> <p>Measurement:</p>		<p style="text-align: center;">NA</p> <p>Photo #:</p>	<ul style="list-style-type: none"> • Replace or remove mats • •
<p>1.49 Are edges of carpets or mats securely attached to minimize tripping hazards?</p>	<p><input type="checkbox"/> Yes <input type="checkbox"/> No</p>		<p style="text-align: center;">NA</p> <p>Photo #:</p>	<ul style="list-style-type: none"> • Secure carpeting or mats at edges • •

ADA Checklist for Readily Achievable Barrier Removal

Priority 2 – Access to Goods & Services



Project **SDDOT Rest Area Improvements**
FHU Reference Number 13-039-01
TSP Project Number 03120855

Building **HOMESTEAD**

Location **29 N/S., MRM 26**

Date **09-17-2013 (Inspection)**

Surveyors **Timothy Roach, AIA**
Todd Schultz, PE

Robert King, CPD

Contact Information **TSP – (605) 343-6102**

The layout of the building should allow people with disabilities to obtain goods and services and to participate in activities without assistance.



Institute for Human Centered Design
www.HumanCenteredDesign.org

November 2011



ADA National Network
Questions on the ADA 800-949-4232 voice/tty

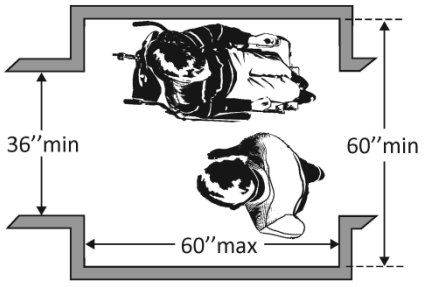
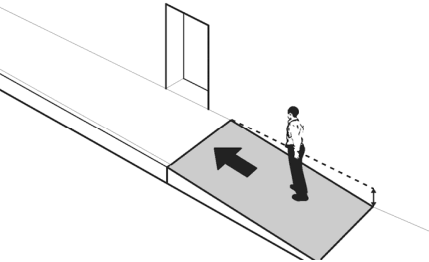
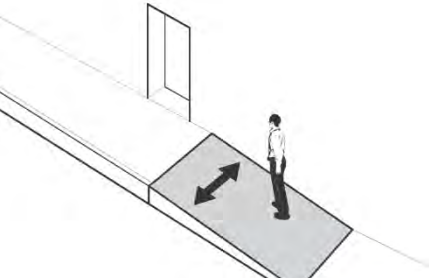

www.ADAchecklist.org

This checklist was produced by the New England ADA Center, a project of the Institute for Human Centered Design and a member of the ADA National Network. This checklist was developed under a grant from the Department of Education, NIDRR grant number H133A060092-09A. However the contents do not necessarily represent the policy of the Department of Education, and you should not assume endorsement by the Federal Government.

Questions or comments on the checklist contact the New England ADA Center at 617-695-0085 voice/tty or ADAinfo@NewEnglandADA.org

For the full set of checklists, including the checklists for recreation facilities visit www.ADAchecklist.org.

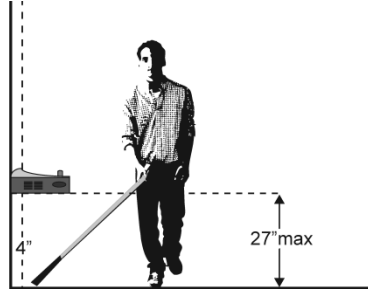
Priority 2 – Access to Goods & Services		Comments	Possible Solutions
<p>2.1 Does the accessible entrance provide direct access to the main floor, lobby and elevator?</p> <p><input checked="" type="checkbox"/> Yes <input type="checkbox"/> No</p>		Photo #:	<ul style="list-style-type: none"> • Create accessible route • •
Interior Accessible Route (2010 Standards – Ch.4)			
<p>2.2 Are all public spaces on at least one accessible route?</p> <p><input checked="" type="checkbox"/> Yes <input type="checkbox"/> No</p>		Photo #: 2.8	<ul style="list-style-type: none"> • Create accessible route • •
<p>2.3 Is the route stable, firm and slip-resistant?</p> <p><input checked="" type="checkbox"/> Yes <input type="checkbox"/> No</p>		Photo #: 2.8	<ul style="list-style-type: none"> • Repair uneven surfaces • •
<p>2.4 Is the route at least 36 inches wide?</p> <p>Note: The accessible route can narrow to 32 inches min. for a max. of 24 inches. These narrower portions of the route must be at least 48 inches from each other.</p>	<p><input checked="" type="checkbox"/> Yes <input type="checkbox"/> No</p> <p>Measurement:</p>	<p>36" min</p> <p>24" max 48" max 24" max</p> <p>32" min 32" min</p>	<p>Photo #:</p> <ul style="list-style-type: none"> • Widen route • •

<p>2.5 If the route is greater than 200 feet in length and no less than 36 inches wide, is there a passing space no less than 60 x 60 inches?</p>	<p><input type="checkbox"/> Yes <input type="checkbox"/> No</p> <p>Measurement:</p>		<p style="text-align: center;">NA</p> <p>Photo #:</p>	<ul style="list-style-type: none"> • Widen route for passing space • •
<p>2.6 Is the running slope no steeper than 1:20, i.e. for every inch of height change there are at least 20 inches of route run?</p>	<p><input type="checkbox"/> Yes <input type="checkbox"/> No</p> <p>Measurement:</p>		<p style="text-align: center;">NA</p> <p>Photo #:</p>	<ul style="list-style-type: none"> • Regrade • If steeper than 1:20 and no steeper than 1:12, treat as ramp and add other features such as edge protection and handrails •
<p>2.7 Is the cross slope no steeper than 1:48?</p>	<p><input type="checkbox"/> Yes <input type="checkbox"/> No</p> <p>Measurement:</p>		<p style="text-align: center;">NA</p> <p>Photo #:</p>	<ul style="list-style-type: none"> • Regrade • •
<p>2.8 Do all objects on circulation paths through public areas, e.g. fire extinguishers, drinking fountains, signs, etc., protrude no more than 4 inches into the path? Or If an object protrudes more than 4 inches, is the bottom leading edge at 27 inches or lower above the floor?</p>	<p><input type="checkbox"/> Yes <input checked="" type="checkbox"/> No</p> <p>Measurement: 18 1/2"</p> <p><input checked="" type="checkbox"/> Yes <input type="checkbox"/> No</p> <p>Measurement: 25 1/2" ABOVE FLOOR & 19" PROJ. FROM WALL</p>	 <p style="text-align: center;">Or</p>	<p style="text-align: center;">ELECTRIC WATER COOLER</p> <p>Photo #: 2.8</p>	<ul style="list-style-type: none"> • Remove object • Add tactile warning such as permanent planter or partial walls •

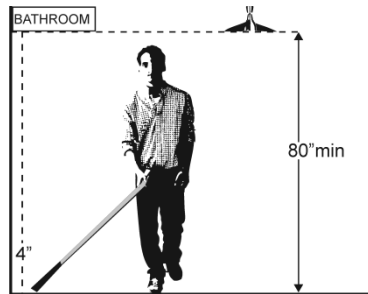
Or
Is the bottom leading edge at 80 inches or higher above the floor?

Yes No

Measurement:
87"



Or



**SECURITY CAMERA –
87" ABOVE FLOOR**

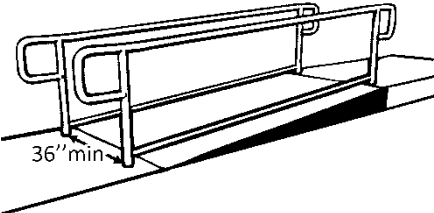
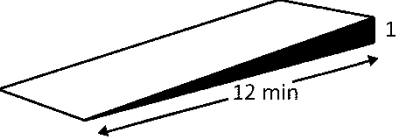
Photo #:

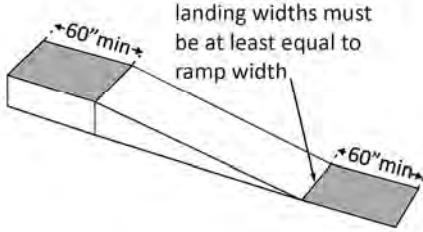
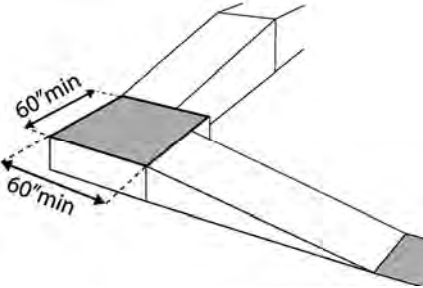
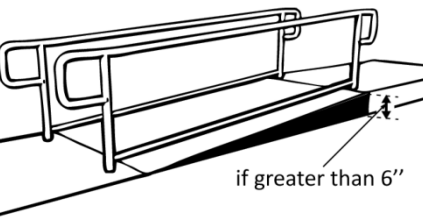
2.9 Are there elevators or platform lifts to all public stories?*

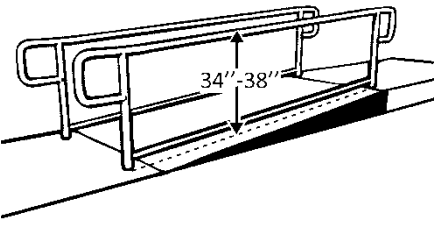
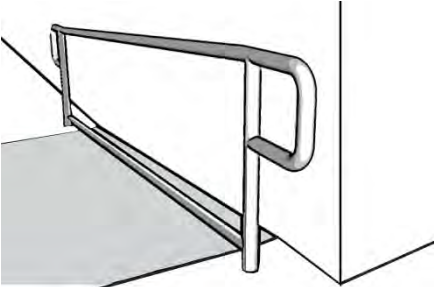
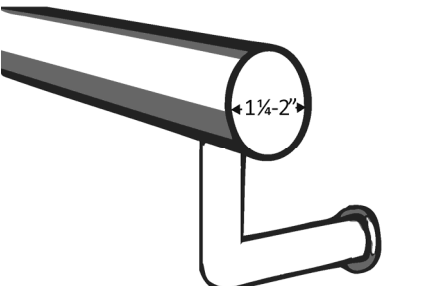
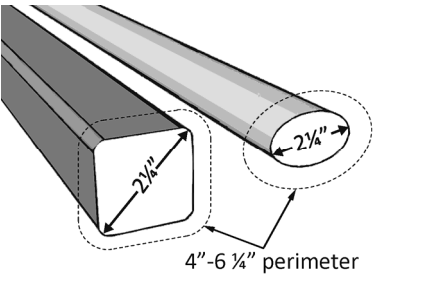
Yes No

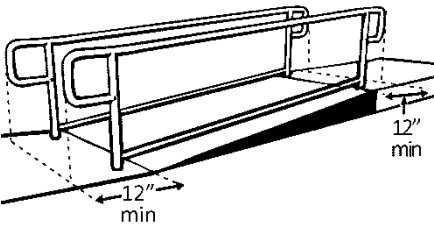
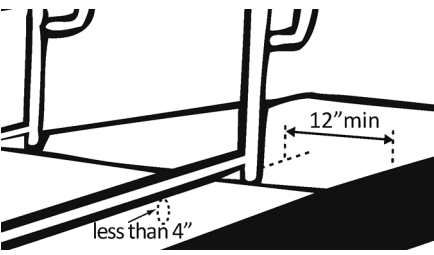
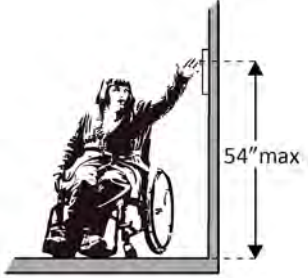
NA

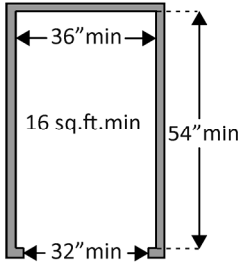
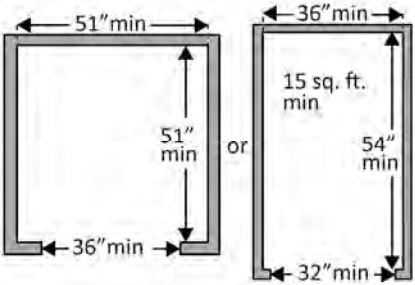
*Vertical access is not required in new construction or alterations if a facility is less than three stories or has less than 3,000 square feet per story, unless a facility is a shopping center, shopping mall, professional office of a health care provider, transportation terminal, state facility or government facility

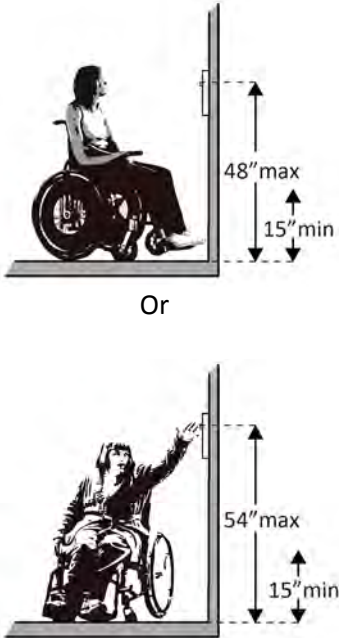

				<ul style="list-style-type: none"> • Install if necessary • Offer goods and services on an accessible story •
			Photo #:	
Ramps (2010 Standards 404 & 505)				
<p>2.10 If there is a ramp, is it at least 36 inches wide? If there are handrails, measure between the handrails.</p>	<input type="checkbox"/> Yes <input type="checkbox"/> No Measurement:		<p style="text-align: center; color: red; font-weight: bold;">NA</p>	<ul style="list-style-type: none"> • Alter ramp • •
			Photo #:	
<p>2.11 Is the surface stable, firm and slip resistant?</p>	<input type="checkbox"/> Yes <input type="checkbox"/> No		<p style="text-align: center; color: red; font-weight: bold;">NA</p>	<ul style="list-style-type: none"> • Change surface • •
			Photo #:	
<p>2.12 For each section of the ramp, is the running slope no greater than 1:12, i.e. for every inch of height change there are at least 12 inches of ramp run?</p> <p>Note: Rises no greater than 3 inches with a slope no steeper than 1:8 and rises no greater than 6 inches with a slope no steeper than 1:10 are permitted when due to space limitations.</p>	<input type="checkbox"/> Yes <input type="checkbox"/> No Measurement:		<p style="text-align: center; color: red; font-weight: bold;">NA</p>	<ul style="list-style-type: none"> • Lengthen ramp to decrease slope • Reconfigure ramp to include switchbacks • Relocate ramp •
			Photo #:	

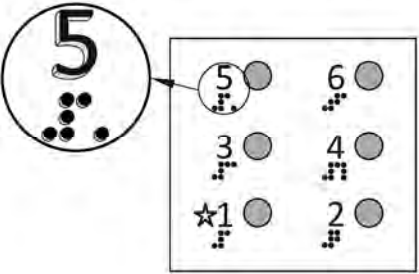
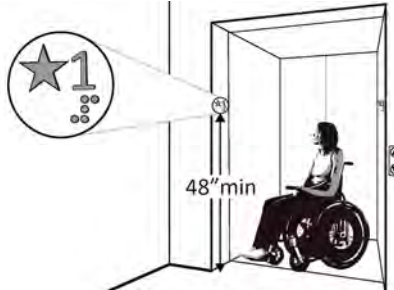
<p>2.13 Is there a level landing that is at least 60 inches long and at least as wide as the ramp:</p> <p>At the top of the ramp?</p> <p>At the bottom of the ramp?</p>	<p><input type="checkbox"/> Yes <input type="checkbox"/> No</p> <p>Measurement:</p> <p><input type="checkbox"/> Yes <input type="checkbox"/> No</p> <p>Measurement:</p>		<p style="text-align: center; color: red; font-weight: bold;">NA</p> <p>Photo #:</p>	<ul style="list-style-type: none"> • Alter ramp • Relocate ramp •
<p>2.14 Is there a level landing where the ramp changes direction that is at least 60 x 60 inches?</p>	<p><input type="checkbox"/> Yes <input type="checkbox"/> No</p> <p>Measurement:</p>		<p style="text-align: center; color: red; font-weight: bold;">NA</p> <p>Photo #:</p>	<ul style="list-style-type: none"> • Increase landing size • •
<p>2.15 If the ramp has a rise higher than 6 inches are there handrails on both sides?</p>	<p><input type="checkbox"/> Yes <input type="checkbox"/> No</p> <p>Measurement:</p>		<p style="text-align: center; color: red; font-weight: bold;">NA</p> <p>Photo #:</p>	<ul style="list-style-type: none"> • Add handrails • •


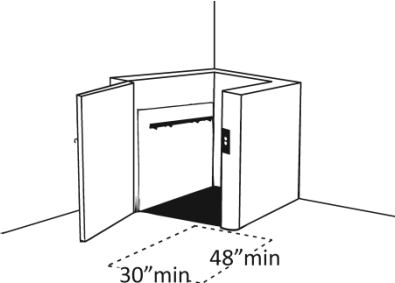
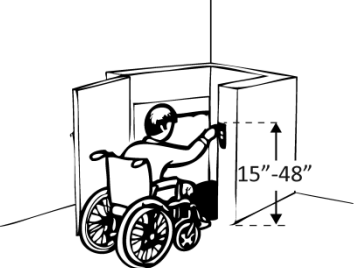
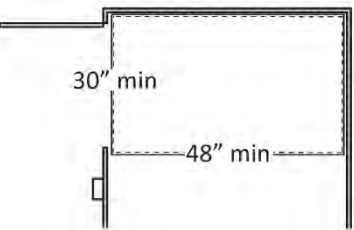
<p>2.16 Is the top of the handrail gripping surface no less than 34 inches and no greater than 38 inches above the ramp surface?</p>	<p><input type="checkbox"/> Yes <input type="checkbox"/> No</p> <p>Measurement:</p>		<p style="text-align: center;">NA</p> <p>Photo #:</p>	<ul style="list-style-type: none"> • Adjust handrail height • •
<p>2.17 Is the handrail gripping surface continuous and not obstructed along the top or sides?</p> <p>If there are obstructions, is the bottom of the handrail gripping surface obstructed by no more than 20%?</p>	<p><input type="checkbox"/> Yes <input type="checkbox"/> No</p> <p><input type="checkbox"/> Yes <input type="checkbox"/> No</p> <p>Measurement:</p>		<p style="text-align: center;">NA</p> <p>Photo #:</p>	<ul style="list-style-type: none"> • Regrade to 1:20 max • If steeper than 1:20 and no steeper than 1:12, treat as a ramp and add other features such as edge protection and handrails •
<p>2.18 If the handrail gripping surface is circular, is it no less than 1 ¼ inches and no greater than 2 inches in diameter?</p>	<p><input type="checkbox"/> Yes <input type="checkbox"/> No</p> <p>Measurement:</p>		<p style="text-align: center;">NA</p> <p>Photo #:</p>	<ul style="list-style-type: none"> • Alter handrails • •
<p>2.19 If the handrail gripping surface is non-circular, is it no less than 4 inches and no greater than 6 ½ inches in perimeter and no more than 2 ¼ inches in cross section?</p>	<p><input type="checkbox"/> Yes <input type="checkbox"/> No</p> <p>Measurement:</p>		<p style="text-align: center;">NA</p> <p>Photo #:</p>	<ul style="list-style-type: none"> • Alter handrails • •

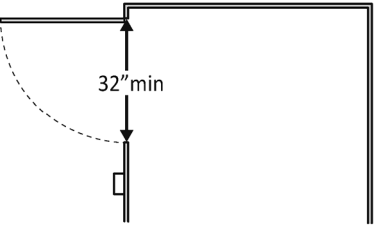
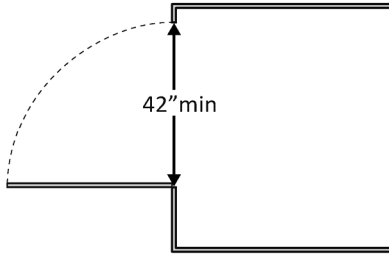
<p>2.20 Does the handrail:</p> <p>Extend at least 12 inches beyond the top and bottom of the ramp?</p> <p>Return to a wall, guard, or landing surface?</p>	<p><input type="checkbox"/> Yes <input type="checkbox"/> No</p> <p>Measurement:</p> <p><input type="checkbox"/> Yes <input type="checkbox"/> No</p>		<p style="text-align: center;">NA</p> <p>Photo #:</p>	<ul style="list-style-type: none"> • Alter handrails • • <p>If a 12" extension would be hazardous (in circulation path), it is not required</p>
<p>2.21 To prevent wheelchair casters and crutch tips from falling off:</p> <p>Does the surface of the ramp extend at least 12 inches beyond the inside face of the handrail?</p> <p>Or</p> <p>Is there a curb or barrier that prevents the passage of a 4-inch diameter sphere?</p>	<p><input type="checkbox"/> Yes <input type="checkbox"/> No</p> <p>Measurement:</p> <p><input type="checkbox"/> Yes <input type="checkbox"/> No</p> <p>Measurement:</p>		<p style="text-align: center;">NA</p> <p>Photo #:</p>	<ul style="list-style-type: none"> • Add curb • Add barrier • Extend ramp width • •
<p>Elevators – Full Size & LULA (limited use, limited application) (2010 Standards – 407 & 408) Note: LULA elevators are often used in alterations.</p>				
<p>2.22 If there is a full size or LULA elevator, are the call buttons no higher than 54 inches above the floor?</p>	<p><input type="checkbox"/> Yes <input type="checkbox"/> No</p> <p>Measurement:</p>		<p style="text-align: center;">NA</p> <p>Photo #:</p>	<ul style="list-style-type: none"> • Change call button height • •
<p>2.23 If there is a full size or LULA elevator, does the sliding door reopen automatically when obstructed by an object or person?*</p>	<p><input type="checkbox"/> Yes <input type="checkbox"/> No</p>		<p style="text-align: center;">NA</p>	<p>* If constructed before 3/15/2012 and manually operated, the door is not required to reopen automatically</p>

			<p>Photo #:</p>	<ul style="list-style-type: none"> • Install opener •
<p>2.24 If there is a LULA elevator with a swinging door:</p> <p>Is the door power- operated? <input type="checkbox"/> Yes <input type="checkbox"/> No</p> <p>Does the door remain open for at least 20 seconds when activated? <input type="checkbox"/> Yes <input type="checkbox"/> No</p> <p>Time:</p>			<p>Photo #:</p> <p style="text-align: center;">NA</p>	<ul style="list-style-type: none"> • Add power operated door • Adjust opening time •
<p>2.25 If there is a full size elevator:</p> <p>Is the interior at least 54 inches deep by at least 36 inches wide with at least 16 sq. ft. of clear floor area? <input type="checkbox"/> Yes <input type="checkbox"/> No</p> <p>Measurement:</p> <p>Is the door opening width at least 32 inches? <input type="checkbox"/> Yes <input type="checkbox"/> No</p> <p>Measurement:</p>			<p>Photo #:</p> <p style="text-align: center;">NA</p>	<ul style="list-style-type: none"> • Replace elevator • •
<p>2.26 If there is a LULA elevator, is the interior:</p> <p>At least 51 x 51 inches with a door opening width of at least 36 inches? <input type="checkbox"/> Yes <input type="checkbox"/> No</p> <p>Measurement:</p> <p>Or</p> <p>At least 54 inches deep by at least 36 inches wide with at least 15 sq. ft. of clear floor <input type="checkbox"/> Yes <input type="checkbox"/> No</p> <p>Measurement:</p>			<p>Photo #:</p> <p style="text-align: center;">NA</p>	<ul style="list-style-type: none"> • Replace elevator • •

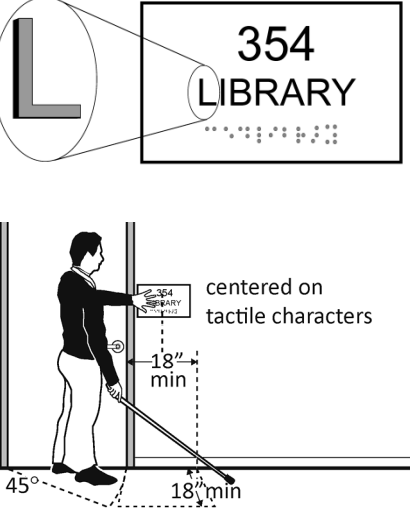
<p>area and a door opening width of at least 32 inches?</p>			<p>Photo #:</p>	
<p>2.27 If there is a full size or LULA elevator, are the in-car controls:</p> <p>No less than 15 inches and no greater 48 inches above the floor? Or Up to 54 inches above the floor for a parallel approach?</p>	<p><input type="checkbox"/> Yes <input type="checkbox"/> No Measurement:</p> <p><input type="checkbox"/> Yes <input type="checkbox"/> No Measurement:</p>	 <p>Or</p>	<p style="text-align: center;">NA</p> <p>Photo #:</p>	<ul style="list-style-type: none"> • Change control height • •
<p>2.28 If there is a LULA elevator, are the in-car controls centered on a side wall?</p>	<p><input type="checkbox"/> Yes <input type="checkbox"/> No Measurement:</p>		<p style="text-align: center;">NA</p> <p>Photo #:</p>	<ul style="list-style-type: none"> • Reconfigure controls • •

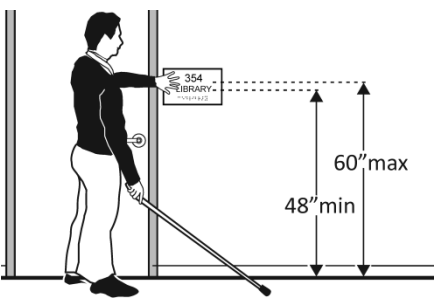
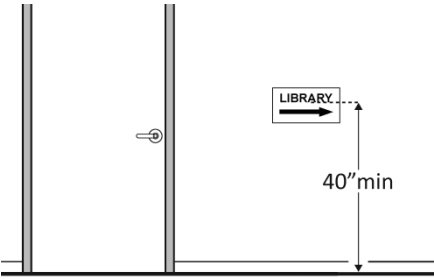
<p>2.29 If there is a full size or LULA elevator:</p> <p>Are the car control buttons designated with raised characters?</p> <p>Are the car control buttons designated with Braille?</p>	<p><input type="checkbox"/> Yes <input type="checkbox"/> No</p> <p><input type="checkbox"/> Yes <input type="checkbox"/> No</p>		<p style="text-align: center;">NA</p> <p>Photo #:</p>	<ul style="list-style-type: none"> • Add raised characters • Add Braille •
<p>2.30 If there is a full size or LULA elevator, are there audible signals which sound as the car passes or is about to stop at a floor?</p>	<p><input type="checkbox"/> Yes <input type="checkbox"/> No</p>		<p style="text-align: center;">NA</p> <p>Photo #:</p>	<ul style="list-style-type: none"> • Install audible signals • •
<p>2.31 If there is a full size or LULA elevator:</p> <p>Is there a sign on both door jambs at every floor identifying the floor?</p> <p>Is there a tactile star on both jambs at the main entry level?</p> <p>Do text characters contrast with their backgrounds?</p> <p>Are text characters raised?</p> <p>Is there Braille?</p> <p>Is the sign mounted between 48 inches to the baseline of the lowest character and 60 inches to the baseline of the highest character above the floor?*</p>	<p><input type="checkbox"/> Yes <input type="checkbox"/> No</p> <p><input type="checkbox"/> Yes <input type="checkbox"/> No</p> <p><input type="checkbox"/> Yes <input type="checkbox"/> No</p> <p><input type="checkbox"/> Yes <input type="checkbox"/> No</p> <p><input type="checkbox"/> Yes <input type="checkbox"/> No</p> <p><input type="checkbox"/> Yes <input type="checkbox"/> No</p> <p>Measurement:</p>		<p style="text-align: center;">NA</p> <p>Photo #:</p>	<ul style="list-style-type: none"> • Install signs • Change sign height • • <p>* If constructed before 3/15/2012 and mounted no higher than 60 inches to the centerline of the sign, relocation is not required</p>

Platform Lifts (2010 Standards – 410)				
<p>2.32 If a lift is provided, can it be used without assistance from others?</p>	<p><input type="checkbox"/> Yes <input type="checkbox"/> No</p>		<p style="text-align: center;">NA</p> <p>Photo #:</p>	<ul style="list-style-type: none"> • Reconfigure so independently operable • •
<p>2.33 Is there a clear floor space at least 30 inches wide by at least 48 inches long for a person using a wheelchair to approach and reach the controls to use the lift?</p>	<p><input type="checkbox"/> Yes <input type="checkbox"/> No</p> <p>Measurement:</p>		<p style="text-align: center;">NA</p> <p>Photo #:</p>	<ul style="list-style-type: none"> • Remove obstructions • •
<p>2.34 Are the lift controls no less than 15 inches and no greater than 48 inches above the floor?</p>	<p><input type="checkbox"/> Yes <input type="checkbox"/> No</p> <p>Measurement:</p>		<p style="text-align: center;">NA</p> <p>Photo #:</p>	<ul style="list-style-type: none"> • Change control height • •
<p>2.35 Is there a clear floor space at least 30 inches wide by at least 48 inches long inside the lift?</p>	<p><input type="checkbox"/> Yes <input type="checkbox"/> No</p> <p>Measurement:</p>		<p style="text-align: center;">NA</p> <p>Photo #:</p>	<ul style="list-style-type: none"> • Replace lift • •

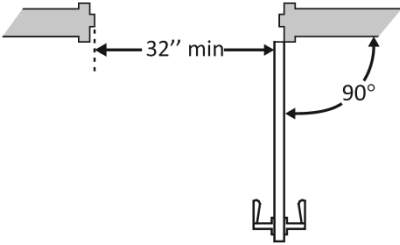
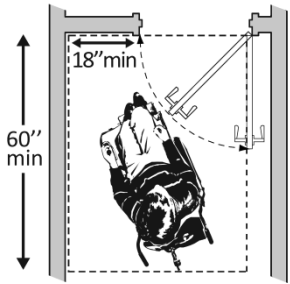
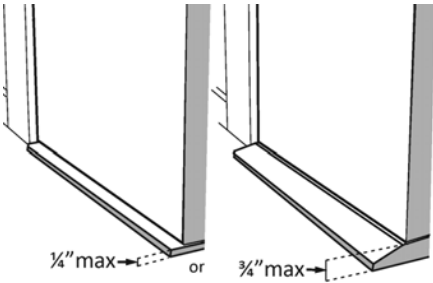
<p>2.36 If there is an end door, is the clear opening width at least 32 inches?</p>	<p><input type="checkbox"/> Yes <input type="checkbox"/> No</p> <p>Measurement:</p>		<p style="text-align: center; color: red; font-weight: bold;">NA</p> <p>Photo #:</p>	<ul style="list-style-type: none"> • Alter door width • •
<p>2.37 If there is a side door, is the clear opening width at least 42 inches?</p>	<p><input type="checkbox"/> Yes <input type="checkbox"/> No</p> <p>Measurement:</p>		<p style="text-align: center; color: red; font-weight: bold;">NA</p> <p>Photo #:</p>	<ul style="list-style-type: none"> • Alter door width • •

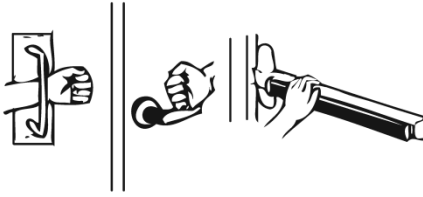
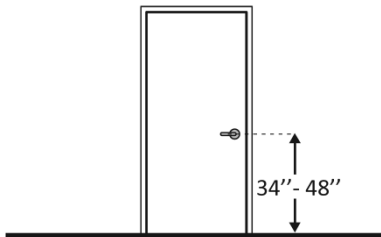
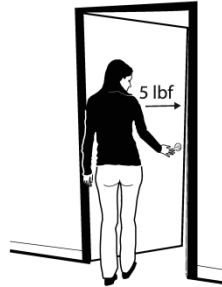
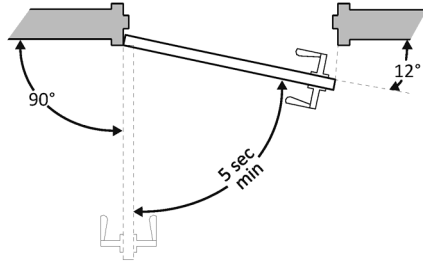
Signs (2010 Standards – 703) Note: “Tactile characters” are read using touch, i.e. raised characters and Braille.

<p>2.38 If there are signs designating permanent rooms and spaces not likely to change over time, e.g. room numbers and letters, room names, and exit signs:</p> <p>Do text characters contrast with their backgrounds?</p> <p>Are text characters raised?</p> <p>Is there Braille?</p> <p>Is the sign mounted: On the wall on the latch side of the door?</p>	<p><input checked="" type="checkbox"/> Yes <input type="checkbox"/> No</p> <p><input checked="" type="checkbox"/> Yes <input type="checkbox"/> No</p> <p><input checked="" type="checkbox"/> Yes <input type="checkbox"/> No</p> <p><input checked="" type="checkbox"/> Yes <input type="checkbox"/> No</p>		<p>Photo #:</p>	<ul style="list-style-type: none"> • Install tactile sign • Relocate sign •
---	---	---	-----------------	--

<p>Note: Signs are permitted on the push side of doors with closers and without hold-open devices.</p> <p>With clear floor space beyond the arc of the door swing between the closed position and 45-degree open position, at least 18 x 18 inches centered on the tactile characters?*</p> <p>So the baseline of the lowest character is at least 48 inches above the floor and the baseline of the highest character is no more than 60 inches above the floor? *</p> <p>Note: If the sign is at double doors with one active leaf, the sign should be on the inactive leaf; if both leaves are active, the sign should be on the wall to the right of the right leaf.</p>	<p><input type="checkbox"/> Yes <input type="checkbox"/> No</p> <p>Measurement: NA</p> <p><input checked="" type="checkbox"/> Yes <input type="checkbox"/> No</p> <p>Measurement: 53" BOTTOM 60" TOP</p>		<p>Photo #: 2.38</p>	<p>*If constructed before 3/15/2010 and a person may approach within 3 inches of the sign without encountering protruding objects or standing within the door swing, relocation not required</p> <p>*If constructed before 3/15/2012 and mounted no higher than 60 inches to the centerline of the sign, relocation not required</p>
<p>2.39 If there are signs that provide direction to or information about interior spaces:</p> <p>Do text characters contrast with their backgrounds?</p> <p>Is the sign mounted so that characters are at least 40 inches above the floor?</p>	<p><input type="checkbox"/> Yes <input type="checkbox"/> No</p> <p><input type="checkbox"/> Yes <input type="checkbox"/> No</p> <p>Measurement:</p>		<p>Photo #: NA</p>	<ul style="list-style-type: none"> • Install signs with contrasting characters • Change sign height • <p>Raised characters and Braille are not required</p>

Interior Doors – to classrooms, medical exam rooms, conference rooms, etc. (2010 Standards – 404)

<p>2.40 Is the door opening width at least 32 inches clear, between the face of the door and the stop, when the door is open 90 degrees?</p>	<p><input type="checkbox"/> Yes <input type="checkbox"/> No</p> <p>Measurement:</p>		<p style="text-align: center;">NA</p> <p>Photo #:</p>	<ul style="list-style-type: none"> • Install offset hinges • Alter the doorway •
<p>2.41 If there is a front approach to the pull side of the door, is there at least 18 inches of maneuvering clearance beyond the latch side plus at least 60 inches clear depth?</p> <p>On both sides of the door, is the floor surface of the maneuvering clearance level (no steeper than 1:48)?</p>	<p><input type="checkbox"/> Yes <input type="checkbox"/> No</p> <p>Measurement:</p> <p><input type="checkbox"/> Yes <input type="checkbox"/> No</p> <p>Measurement:</p>		<p style="text-align: center;">NA</p> <p>Photo #:</p>	<ul style="list-style-type: none"> • Remove obstructions • Reconfigure walls • Add automatic door opener <p>See 2010 Standards 404.2.4 for maneuvering clearance requirements on the push side of the door and side approaches to the pull side of the door</p>
<p>2.42 Is the door threshold edge no more than ¼ inch high?</p> <p>Or</p> <p>No more than ¾ inch high if slope is beveled no steeper than 1:2?</p> <p>Note: The first ¼ inch of the threshold may be vertical; the rest must be beveled.</p>	<p><input type="checkbox"/> Yes <input type="checkbox"/> No</p> <p>Measurement:</p> <p><input type="checkbox"/> Yes <input type="checkbox"/> No</p> <p>Measurement:</p>		<p style="text-align: center;">NA</p> <p>Photo #:</p>	<ul style="list-style-type: none"> • Remove or replace threshold • •

<p>2.43 Is the door equipped with hardware that is operable with one hand and does not require tight grasping, pinching and twisting of the wrist?</p>	<p><input type="checkbox"/> Yes <input type="checkbox"/> No</p>		<p style="text-align: center;">NA</p> <p>Photo #:</p>	<ul style="list-style-type: none"> • Replace inaccessible knob with lever, loop or push hardware • Add automatic door opener •
<p>2.44 Are the operable parts of the hardware no less than 34 inches and no greater than 48 inches above the floor?</p>	<p><input type="checkbox"/> Yes <input type="checkbox"/> No</p> <p>Measurement:</p>		<p style="text-align: center;">NA</p> <p>Photo #:</p>	<ul style="list-style-type: none"> • Change hardware height • •
<p>2.45 Can the door be opened easily (5 pounds maximum force)?</p> <p>Note: You can use a pressure gauge or fish scale to measure force. If you do not have a pressure gauge or fish scale you will need to judge whether the door is easy to open.</p>	<p><input type="checkbox"/> Yes <input type="checkbox"/> No</p> <p>Measurement:</p>		<p style="text-align: center;">NA</p> <p>Photo #:</p>	<ul style="list-style-type: none"> • Adjust or replace closers • Install lighter doors • Install power-assisted or automatic door openers
<p>2.46 If the door has a closer, does it take at least 5 seconds to close from an open position of 90 degrees to a position of 12 degrees from the latch?</p>	<p><input type="checkbox"/> Yes <input type="checkbox"/> No</p> <p>Measurement:</p>		<p style="text-align: center;">NA</p> <p>Photo #:</p>	<ul style="list-style-type: none"> • Adjust closer • •

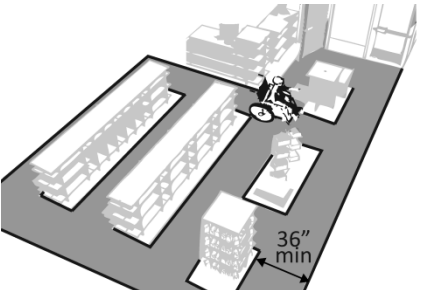

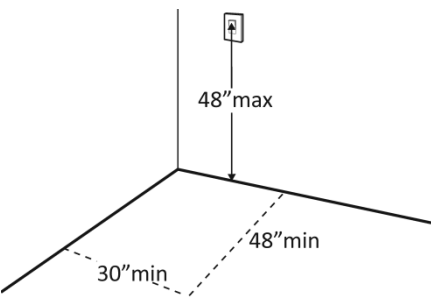
Rooms and Spaces – stores, supermarkets, libraries, etc. (2010 Standards – 302, 304, & 402)				
<p>2.47 Are aisles and pathways to goods and services, and to one of each type of sales and service counters, at least 36 inches wide?</p>	<p><input checked="" type="checkbox"/> Yes <input type="checkbox"/> No</p> <p>Measurement: 80"</p>		<p>Photo #: 2.47</p>	<ul style="list-style-type: none"> • Rearrange goods, equipment and furniture • •
<p>2.48 Are floor surfaces stable, firm and slip resistant?</p>	<p><input checked="" type="checkbox"/> Yes <input type="checkbox"/> No</p>		<p>Photo #: 2.48</p>	<ul style="list-style-type: none"> • Change floor surface • •
<p>2.49 If there is carpet:</p> <p>Is it no higher than ½ inch?</p> <p>Is it securely attached along the edges?</p>	<p><input type="checkbox"/> Yes <input type="checkbox"/> No</p> <p>Measurement:</p> <p><input type="checkbox"/> Yes <input type="checkbox"/> No</p>		<p>NA</p> <p>Photo #:</p>	<ul style="list-style-type: none"> • Replace carpet • •
Controls – light switches, security and intercom systems, emergency/alarm boxes, etc. (2010 Standards – 309)				
<p>2.50 Is there a clear floor space at least 30 inches wide by at least 48 inches long for a forward or parallel approach?</p> <p>Are the operable parts no higher than 48 inches above the floor?*</p>	<p><input type="checkbox"/> Yes <input type="checkbox"/> No</p> <p>Measurement:</p> <p><input type="checkbox"/> Yes <input type="checkbox"/> No</p> <p>Measurement:</p>		<p>NA</p>	<ul style="list-style-type: none"> • Change height of control • • <p>*If constructed before 3/15/2012 and a parallel approach is provided, controls can be 54 inches above the floor</p>

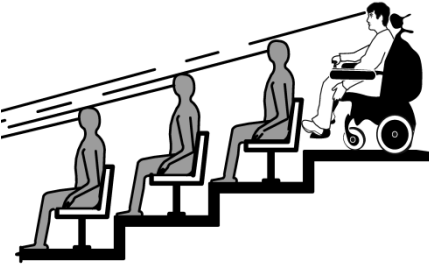
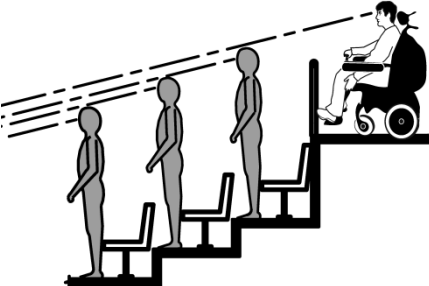

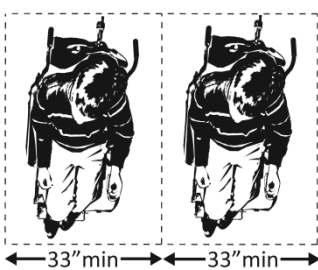
			Photo #:	
--	--	--	----------	--

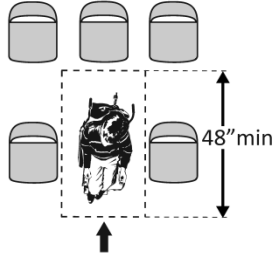
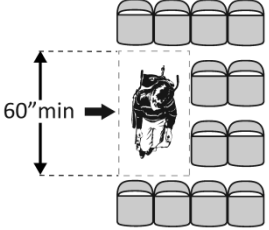
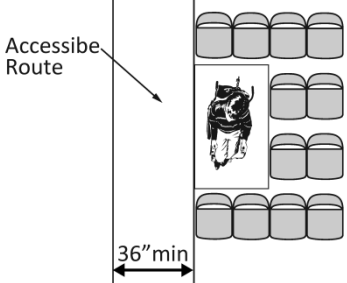
<p>2.51 Can the control be operated with one hand and without tight grasping, pinching, or twisting of the wrist?</p>	<input type="checkbox"/> Yes <input type="checkbox"/> No		<p>Photo #:</p> <p style="text-align: center;">NA</p>	<ul style="list-style-type: none"> • Replace control • •
--	--	--	--	---

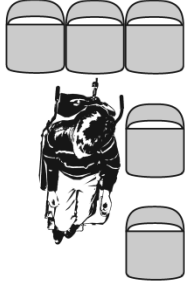

Seating: Assembly Areas – theaters, auditoriums, stadiums, theater style classrooms, etc. (2010 Standards – 221 & 802)

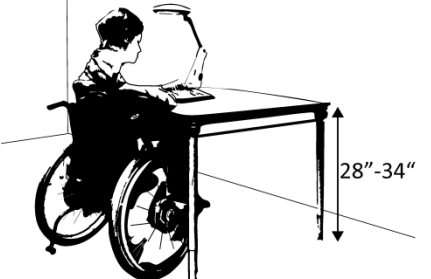
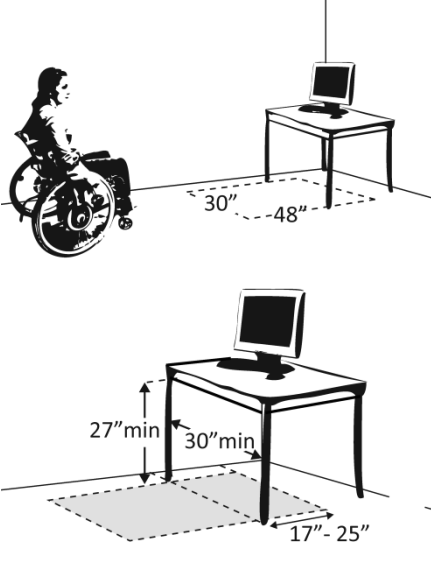
<p>2.52 Are an adequate number of wheelchair spaces provided?</p>	<input type="checkbox"/> Yes <input type="checkbox"/> No	<table border="1"> <thead> <tr> <th># of Seats</th> <th>Wheelchair Spaces</th> </tr> </thead> <tbody> <tr> <td>4 - 25</td> <td>1</td> </tr> <tr> <td>26 - 50</td> <td>2</td> </tr> <tr> <td>51 - 150</td> <td>4</td> </tr> <tr> <td>151 - 300</td> <td>5</td> </tr> <tr> <td colspan="2">300+ see 2010 Standards 221.2.1.</td> </tr> </tbody> </table>	# of Seats	Wheelchair Spaces	4 - 25	1	26 - 50	2	51 - 150	4	151 - 300	5	300+ see 2010 Standards 221.2.1.		<p>Photo #:</p> <p style="text-align: center;">NA</p>	<ul style="list-style-type: none"> • Reconfigure to add wheelchair spaces • •
# of Seats	Wheelchair Spaces															
4 - 25	1															
26 - 50	2															
51 - 150	4															
151 - 300	5															
300+ see 2010 Standards 221.2.1.																

<p>2.53 Are wheelchair spaces dispersed to allow location choices and viewing angles equivalent to other seating, including specialty seating areas that provide distinct services and amenities?</p>	<input type="checkbox"/> Yes <input type="checkbox"/> No		<p>Photo #:</p> <p style="text-align: center;">NA</p>	<ul style="list-style-type: none"> • Reconfigure to disperse wheelchair spaces • •
--	--	--	--	---

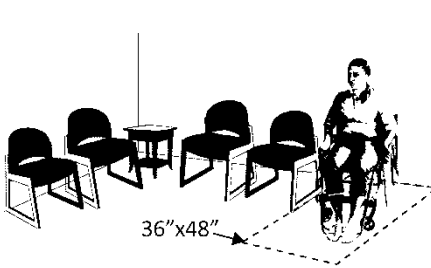
<p>2.54 Where people are expected to remain seated, do people in wheelchair spaces have a clear line of sight over and between the heads of others in front of them?</p>	<p><input type="checkbox"/> Yes <input type="checkbox"/> No</p>		<p style="text-align: center;">NA</p> <p>Photo #:</p>	<ul style="list-style-type: none"> • Alter for line of sight • •
<p>2.55 Where people are expected to stand, do people in wheelchair spaces have a clear line of sight over and between the heads of others in front of them?</p>	<p><input type="checkbox"/> Yes <input type="checkbox"/> No</p>		<p style="text-align: center;">NA</p> <p>Photo #:</p>	<ul style="list-style-type: none"> • Alter for line of sight • •
<p>2.56 If there is a single wheelchair space, is it at least 36 inches wide?</p>	<p><input type="checkbox"/> Yes <input type="checkbox"/> No</p> <p>Measurement:</p>		<p style="text-align: center;">NA</p> <p>Photo #:</p>	<ul style="list-style-type: none"> • Alter space • •
<p>2.57 If there are two adjacent wheelchair spaces, are they each at least 33 inches wide?</p>	<p><input type="checkbox"/> Yes <input type="checkbox"/> No</p> <p>Measurement:</p>		<p style="text-align: center;">NA</p> <p>Photo #:</p>	<ul style="list-style-type: none"> • Alter spaces • •

<p>2.58 If the wheelchair space can be entered from the front or rear, is it at least 48 inches deep?</p>	<p><input type="checkbox"/> Yes <input type="checkbox"/> No</p> <p>Measurement:</p>		<p style="text-align: center;">NA</p> <p>Photo #:</p>	<ul style="list-style-type: none"> • Alter space • •
<p>2.59 If the wheelchair space can only be entered from the side, is it at least 60 inches deep?</p>	<p><input type="checkbox"/> Yes <input type="checkbox"/> No</p> <p>Measurement:</p>		<p style="text-align: center;">NA</p> <p>Photo #:</p>	<ul style="list-style-type: none"> • Alter space • •
<p>2.60 Do wheelchair spaces adjoin, but not overlap, accessible routes?</p>	<p><input type="checkbox"/> Yes <input type="checkbox"/> No</p>		<p style="text-align: center;">NA</p> <p>Photo #:</p>	<ul style="list-style-type: none"> • Alter spaces • •
<p>2.61 Is there at least one companion seat for each wheelchair space?</p>	<p><input type="checkbox"/> Yes <input type="checkbox"/> No</p>		<p style="text-align: center;">NA</p> <p>Photo #:</p>	<ul style="list-style-type: none"> • Add companion seats • •

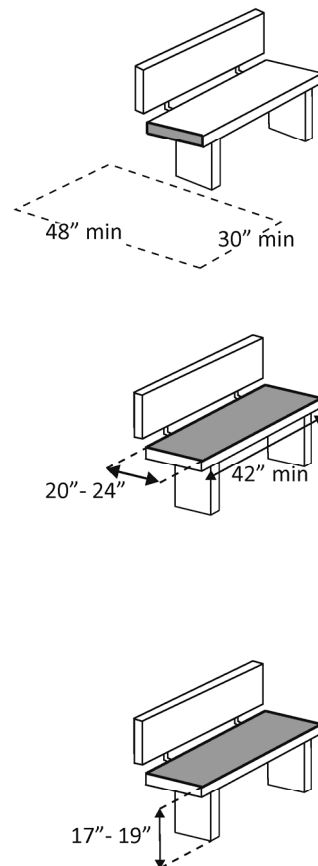
<p>2.62 Is the companion seat located so the companion is shoulder-to-shoulder with the person in a wheelchair?</p>	<p><input type="checkbox"/> Yes <input type="checkbox"/> No</p>		<p style="text-align: center;">NA</p> <p>Photo #:</p>	<ul style="list-style-type: none"> • Alter seating • •
<p>2.63 Is the companion seat equivalent in size, quality, comfort and amenities to seating in the immediate area?</p>	<p><input type="checkbox"/> Yes <input type="checkbox"/> No</p>		<p style="text-align: center;">NA</p> <p>Photo #:</p>	<ul style="list-style-type: none"> • Add equivalent seating • •
<p>Seating: At dining surfaces (restaurants, cafeterias, bars, etc.) and non-employee work surfaces (libraries, conference rooms, etc.) (2010 Standards – 226 & 902)</p>				
<p>2.64 Are at least 5%, but no fewer than one, of seating and standing spaces accessible for people who use wheelchairs?</p>	<p><input type="checkbox"/> Yes <input type="checkbox"/> No</p> <p>Total #:</p> <p>Wheelchair #:</p>		<p style="text-align: center;">NA</p> <p>Photo #:</p>	<ul style="list-style-type: none"> • Alter to provide accessible spaces • •
<p>2.65 Is there a route at least 36 inches wide to accessible seating?</p>	<p><input type="checkbox"/> Yes <input type="checkbox"/> No</p> <p>Measurement:</p>		<p style="text-align: center;">NA</p> <p>Photo #:</p>	<ul style="list-style-type: none"> • Widen route • •

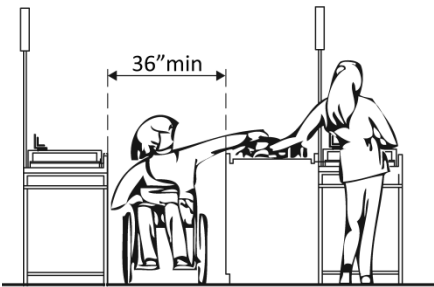
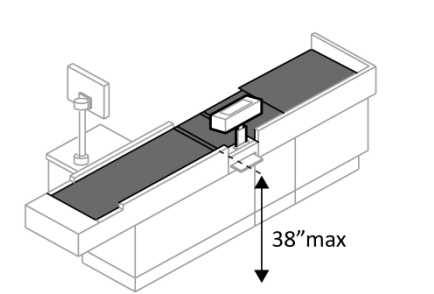
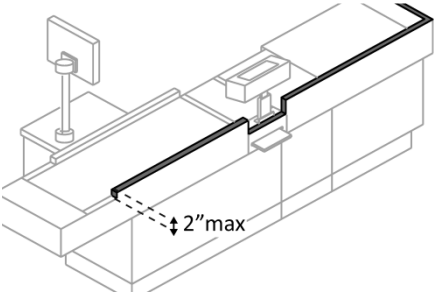
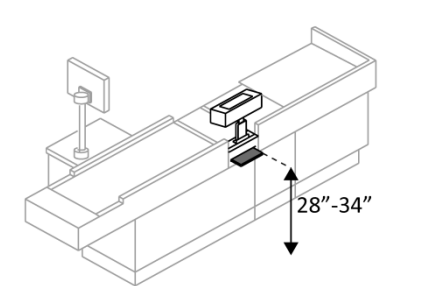
<p>2.66 At the accessible space(s), is the top of the accessible surface no less than 28 inches and no greater than 34 inches above the floor?</p>	<p><input type="checkbox"/> Yes <input type="checkbox"/> No</p> <p>Measurement:</p>		<p style="text-align: center;">NA</p> <p>Photo #:</p>	<ul style="list-style-type: none"> • Alter surface height • •
<p>2.67 Is there a clear floor space at least 30 inches wide by at least 48 inches long for a forward approach?</p> <p>Does it extend no less than 17 inches and no greater than 25 inches under the surface?</p> <p>Is there knee space at least 27 inches high and at least 30 inches wide?</p>	<p><input type="checkbox"/> Yes <input type="checkbox"/> No</p> <p>Measurement:</p> <p><input type="checkbox"/> Yes <input type="checkbox"/> No</p> <p>Measurement:</p> <p><input type="checkbox"/> Yes <input type="checkbox"/> No</p> <p>Measurement:</p>		<p style="text-align: center;">NA</p> <p>Photo #:</p>	<ul style="list-style-type: none"> • Alter table or work surface • Add accessible table or work surface •

Seating: General – reception areas, waiting rooms, etc. (2010 Standards – 801)

<p>2.68 Is there at least one space at least 36 inches wide by at least 48 inches long for a person in a wheelchair?</p>	<p><input type="checkbox"/> Yes <input type="checkbox"/> No</p> <p>Measurement:</p>		<p style="text-align: center;">NA</p> <p>Photo #:</p>	<ul style="list-style-type: none"> • Move furniture and equipment to provide space • •
---	---	--	--	---

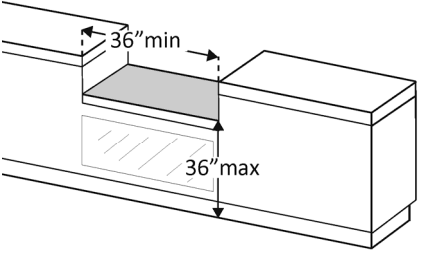
Benches – In locker rooms, dressing rooms, fitting rooms (2010 Standards – 803 & 903)

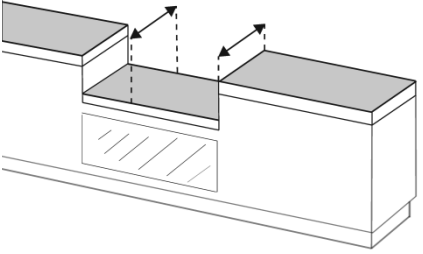
<p>2.69 In locker rooms, dressing rooms and fitting rooms, is there at least one room with a bench?</p>	<p><input type="checkbox"/> Yes <input type="checkbox"/> No</p>		<p style="text-align: center;">NA</p> <p>Photo #:</p>	<ul style="list-style-type: none"> • Add bench • •
<p>2.70 Is there a clear floor space at least 30 inches wide by at least 48 inches long at the end of the bench and parallel to the short axis of the bench?</p> <p>Is the bench seat at least 42 inches long and no less than 20 inches and no greater than 24 inches deep?</p> <p>Does the bench have back support or is it affixed to a wall?</p> <p>Is the top of the bench seat no less than 17 inches and no greater than 19 inches above the floor?</p>	<p><input type="checkbox"/> Yes <input type="checkbox"/> No Measurement:</p> <p><input type="checkbox"/> Yes <input type="checkbox"/> No Measurement:</p> <p><input type="checkbox"/> Yes <input type="checkbox"/> No</p> <p><input type="checkbox"/> Yes <input type="checkbox"/> No Measurement:</p>		<p style="text-align: center;">NA</p> <p>Photo #:</p>	<ul style="list-style-type: none"> • Move bench • Replace bench • Affix bench to wall • •

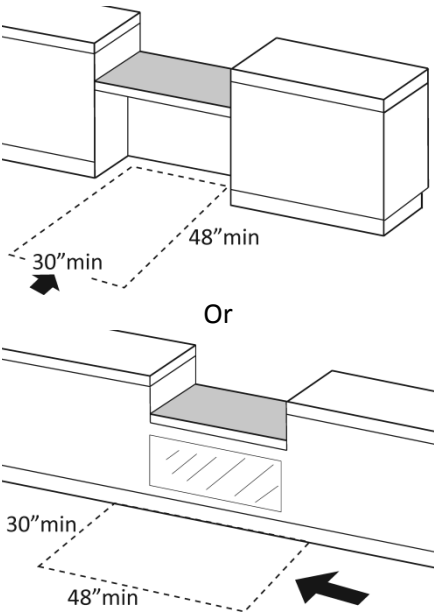
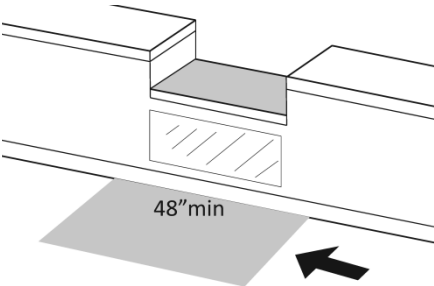
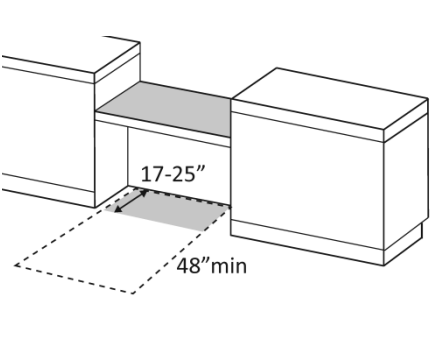
Check-Out Aisles – supermarkets, large retail stores, etc. (2010 Standards – 904)				
<p>2.71 Is the aisle at least 36 inches wide?</p>	<p><input type="checkbox"/> Yes <input type="checkbox"/> No</p> <p>Measurement:</p>		<p>NA</p> <p>Photo #:</p>	<ul style="list-style-type: none"> • Widen aisle • •
<p>2.72 Is the counter surface of at least one aisle no higher than 38 inches above the floor?</p>	<p><input type="checkbox"/> Yes <input type="checkbox"/> No</p> <p>Measurement:</p>		<p>NA</p> <p>Photo #:</p>	<ul style="list-style-type: none"> • Lower counter • •
<p>2.73 Is the top of the counter edge protection no higher than 2 inches above the counter surface?</p>	<p><input type="checkbox"/> Yes <input type="checkbox"/> No</p> <p>Measurement:</p>		<p>NA</p> <p>Photo #:</p>	<ul style="list-style-type: none"> • Lower edge protection • •
<p>2.74 If there is a check writing surface, is the top no less than 28 inches and no greater than 34 inches above the floor?</p>	<p><input type="checkbox"/> Yes <input type="checkbox"/> No</p> <p>Measurement:</p>		<p>NA</p> <p>Photo #:</p>	<ul style="list-style-type: none"> • Alter check writing surface • •

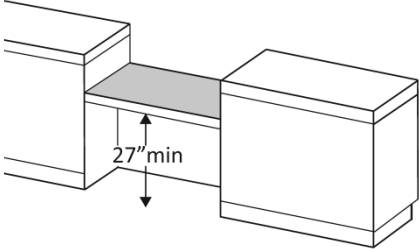
<p>2.75 If there is more than one check-out aisle is there a sign with the International Symbol of Accessibility at the accessible aisle?</p>	<p><input type="checkbox"/> Yes <input type="checkbox"/> No</p>		<p style="text-align: center;">NA</p> <p>Photo #:</p>	<ul style="list-style-type: none"> • Add sign • •
--	---	---	--	--

Sales & Service Counters – banks, stores, dry cleaners, auto repair shops, fitness clubs, etc. (2010 Standards – 904)

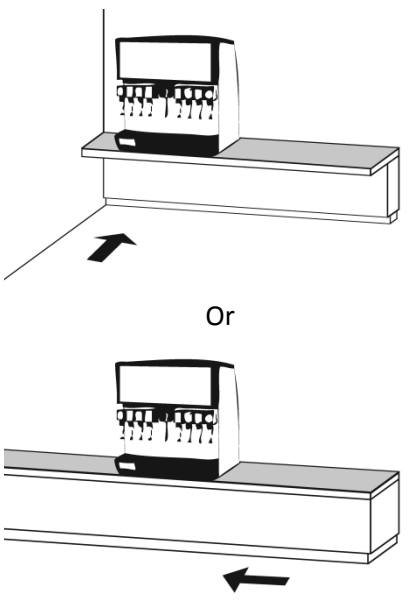
<p>2.76 Is there a portion of at least one of each type of counter that is:</p> <p>No higher than 36 inches above the floor?</p> <p>At least 36 inches long?</p>	<p><input type="checkbox"/> Yes <input checked="" type="checkbox"/> No Measurement: 42 ½"</p> <p><input checked="" type="checkbox"/> Yes <input type="checkbox"/> No Measurement: 15' 0"</p>		<p>Photo #: 2.76</p>	<ul style="list-style-type: none"> • Lower section of counter • Lengthen section of counter •
---	--	--	-----------------------------	--

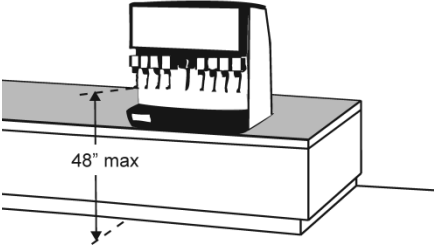
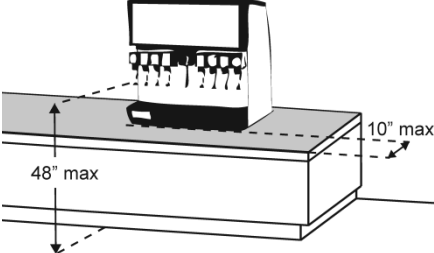
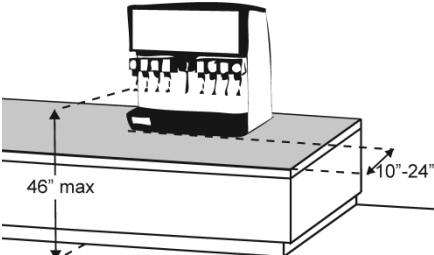
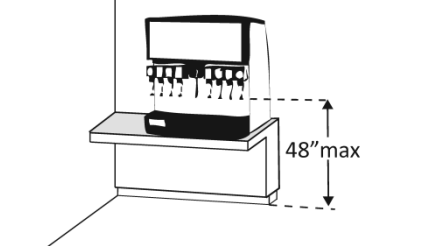
<p>2.77 Does the accessible portion of the counter extend the same depth as the counter top?</p>	<p><input type="checkbox"/> Yes <input type="checkbox"/> No Measurement:</p>		<p style="text-align: center;">NA</p> <p>Photo #:</p>	<ul style="list-style-type: none"> • Alter accessible portion • •
---	--	---	--	--

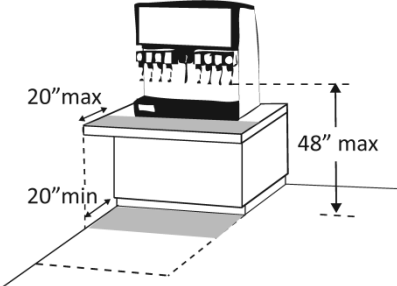
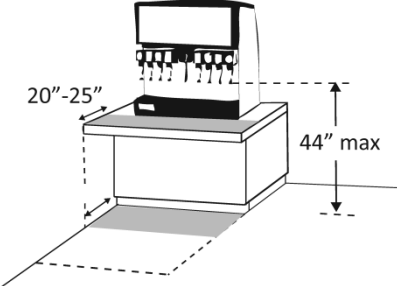
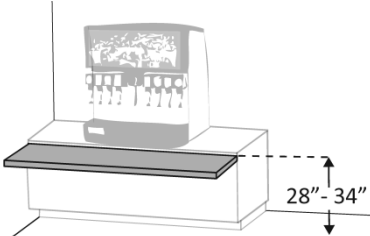
<p>2.78 Is there a clear floor space at least 30 inches wide by at least 48 inches long for a forward or parallel approach?</p>	<p><input type="checkbox"/> Yes <input type="checkbox"/> No</p> <p><input type="checkbox"/> Parallel Measurement:</p> <p><input type="checkbox"/> Forward Measurement:</p>		<p style="text-align: center; color: red; font-weight: bold;">NA</p> <p>Photo #:</p>	<ul style="list-style-type: none"> • Reconfigure to provide a parallel or forward approach • •
<p>2.79 For a parallel approach, is the clear floor space positioned with the 48 inches adjacent to the accessible length of counter?</p>	<p><input type="checkbox"/> Yes <input type="checkbox"/> No</p> <p>Measurement:</p>		<p style="text-align: center; color: red; font-weight: bold;">NA</p> <p>Photo #:</p>	<ul style="list-style-type: none"> • If a parallel approach is not possible, a forward approach is required • •
<p>2.80 For a forward approach:</p> <p>Do no less than 17 and no greater than 25 inches of the clear floor space extend under the accessible length of the counter?</p> <p>Is there at least 27 inches clearance from the floor to the</p>	<p><input type="checkbox"/> Yes <input type="checkbox"/> No</p> <p>Measurement:</p> <p><input type="checkbox"/> Yes <input type="checkbox"/> No</p>		<p style="text-align: center; color: red; font-weight: bold;">NA</p> <p>Photo #:</p>	<ul style="list-style-type: none"> • Reconfigure to provide knee clearance • •

<p>bottom of the counter?</p>	<p>Measurement:</p>		<p>Photo #:</p>	
-------------------------------	---------------------	--	-----------------	--

Food Service Lines – in cafeterias, salad bars, eat-in fast food establishments, etc. (2010 Standards – 904)

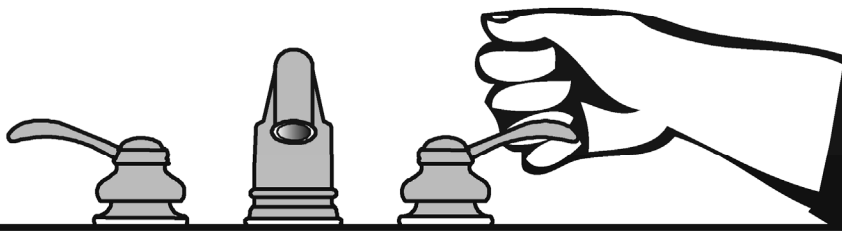
<p>2.81 Does at least one of each type of self-service shelf or dispensing device for tableware, dishware, condiments, food and beverages have a forward or parallel approach?</p>	<p><input type="checkbox"/> Yes <input type="checkbox"/> No</p> <p><input type="checkbox"/> Forward</p> <p><input type="checkbox"/> Parallel</p>		<p style="color: red; text-align: center;">NA</p> <p>Photo #:</p>	<ul style="list-style-type: none"> • Reconfigure to provide approach • •
---	--	---	---	---

<p>2.82 If there is an unobstructed parallel approach, is the shelf or dispensing device no higher than 48 inches above the floor?</p>	<p><input type="checkbox"/> Yes <input type="checkbox"/> No</p> <p>Measurement:</p>		<p>Photo #:</p> <p style="text-align: center;">NA</p>	<ul style="list-style-type: none"> • Lower shelf and/or dispensing device • •
<p>2.83 If there is a shallow obstruction no deeper than 10 inches with a parallel approach, is the shelf or dispensing device no higher than 48 inches above the floor?</p>	<p><input type="checkbox"/> Yes <input type="checkbox"/> No</p> <p>Measurement:</p>		<p>Photo #:</p> <p style="text-align: center;">NA</p>	<ul style="list-style-type: none"> • Lower shelf and/or dispensing device • •
<p>2.84 If there is an obstruction no less than 10 inches and no greater than 24 inches deep with a parallel approach, is the shelf or dispensing device no higher than 46 inches above the floor?</p>	<p><input type="checkbox"/> Yes <input type="checkbox"/> No</p> <p>Measurement:</p>		<p>Photo #:</p> <p style="text-align: center;">NA</p>	<ul style="list-style-type: none"> • Lower shelf and/or dispensing device • •
<p>2.85 If there is an unobstructed forward approach, is the shelf or dispensing device no higher than 48 inches above the floor?</p>	<p><input type="checkbox"/> Yes <input type="checkbox"/> No</p> <p>Measurement:</p>		<p>Photo #:</p> <p style="text-align: center;">NA</p>	<ul style="list-style-type: none"> • Lower shelf and/or dispensing device • •

<p>2.86 If there is an obstruction no deeper than 20 inches with a forward approach:</p> <p>Does clear floor space extend under the obstruction that is at least the same depth as the obstruction?</p> <p>Is the shelf or dispensing device no higher than 48 inches above the floor?</p>	<p><input type="checkbox"/> Yes <input type="checkbox"/> No Measurement:</p> <p><input type="checkbox"/> Yes <input type="checkbox"/> No Measurement:</p>		<p style="text-align: center;">NA</p> <p>Photo #:</p>	<ul style="list-style-type: none"> • Reconfigure to provide knee space • Lower shelf and/or dispensing device •
<p>2.87 If the obstruction is no less than 20 inches and no greater than 25 inches deep with a forward approach:</p> <p>Does clear floor space extend under the obstruction that is at least the same depth as the obstruction?</p> <p>Is the shelf or dispensing device no higher than 44 inches above the floor?</p>	<p><input type="checkbox"/> Yes <input type="checkbox"/> No Measurement:</p> <p><input type="checkbox"/> Yes <input type="checkbox"/> No Measurement:</p>		<p style="text-align: center;">NA</p> <p>Photo #:</p>	<ul style="list-style-type: none"> • Reconfigure to provide knee space • Lower shelf and/or dispensing device •
<p>2.88 If there is a tray slide, is the top no less than 28 inches and no greater than 34 inches above the floor?</p>	<p><input type="checkbox"/> Yes <input type="checkbox"/> No Measurement:</p>		<p style="text-align: center;">NA</p> <p>Photo #:</p>	<ul style="list-style-type: none"> • Reconfigure • •

The ADA Checklist for Readily Achievable Barrier Removal

Priority 3 – Men's Toilet Rooms



Project **SDDOT Rest Area Improvements**
FHU Reference Number 13-039-01
TSP Project Number 03120855

Building **HOMESTEAD**

Location **29 N/S., MRM 26**

Date **09-17-2013 (Inspection)**

Surveyors **Timothy Roach, AIA**
Todd Schultz, PE

Robert King, CPD

Contact Information **TSP – (605) 343-6102**

When toilet rooms are open to the public they should be accessible to people with disabilities.





Institute for Human Centered Design
www.HumanCenteredDesign.org

November 2011



ADA National Network
Questions on the ADA 800-949-4232 voice/tty
www.ADAchecklist.org

Priority 3 – Toilet Rooms		Comments	Possible Solutions
<p>3.1 If toilet rooms are available to the public, is at least one toilet room accessible? (Either one for each sex, or one unisex.)</p> <p><input checked="" type="checkbox"/> Yes <input type="checkbox"/> No</p>		Photo #:	<ul style="list-style-type: none"> • Reconfigure toilet rooms • Combine toilet rooms to create one unisex accessible toilet room •
<p>3.2 Are there signs at inaccessible toilet rooms that give directions to accessible toilet rooms?</p> <p><input type="checkbox"/> Yes <input type="checkbox"/> No</p>		<p>NA</p> <p>Photo #: 3.2</p>	<ul style="list-style-type: none"> • Install signs • •
<p>3.3 If not all toilet rooms are accessible, is there a sign at the accessible toilet room with the International Symbol of Accessibility?</p> <p><input type="checkbox"/> Yes <input type="checkbox"/> No</p>		<p>NA</p> <p>Photo #:</p>	<ul style="list-style-type: none"> • Install sign • •
<p>Accessible Route (2010 Standards – Chapter 4)</p>			
<p>3.4 Is there a route to the accessible toilet room(s) that does not include the use of stairs?</p> <p><input checked="" type="checkbox"/> Yes <input type="checkbox"/> No</p>			<ul style="list-style-type: none"> • Alter route • •
<p>Is the route accessible? (See Priority 2 Interior Accessible Route for specifics.)</p> <p><input checked="" type="checkbox"/> Yes <input type="checkbox"/> No</p>		Photo #: 3.4	

Signs at Toilet Rooms (2010 Standards – 703)

3.5 Do text characters contrast with their backgrounds?

Yes No

Are text characters raised?

Yes No

Is there Braille?

Yes No

Is the sign mounted:
On the wall on the latch side of the door?

Yes No

Note:

Signs are permitted on the push side of doors with closers and without hold-open devices.

With clear floor space beyond the arc of the door swing and 45-degree open position, at least 18 x 18 inches centered on the tactile characters? *

Yes No

Measurement:

NA

So the baseline of the lowest character is at least 48 inches above the floor and the baseline of the highest character is no more than 60 inches above the floor? *

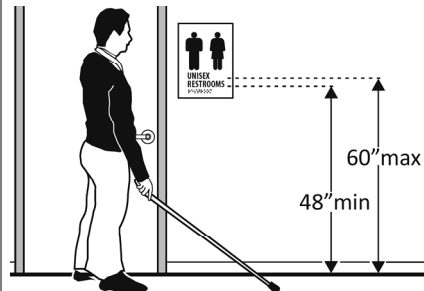
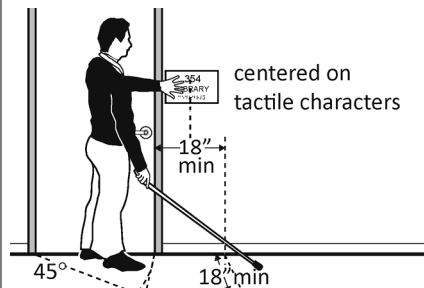
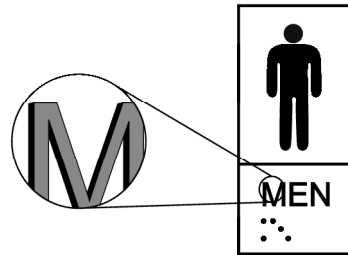
Yes No

Measurement:

NA

Note:

If the sign is at double doors with one active leaf, the sign should be on the inactive leaf; if both leaves are active, the sign

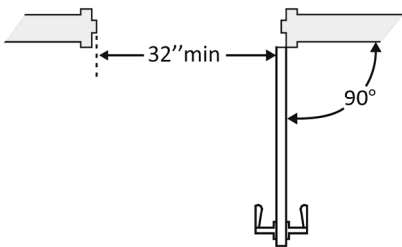
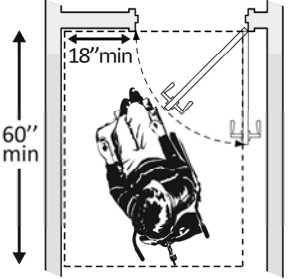
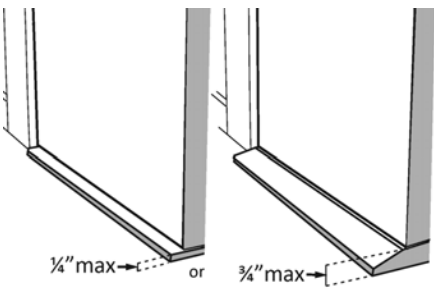


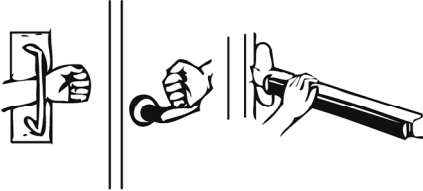
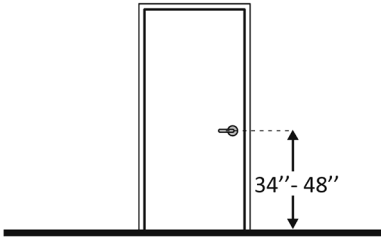

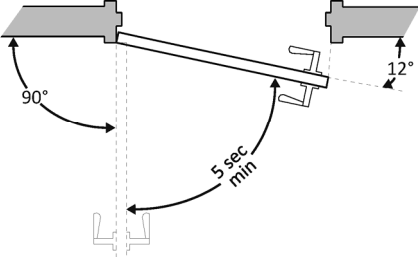
- Install tactile sign
- Relocate sign
-

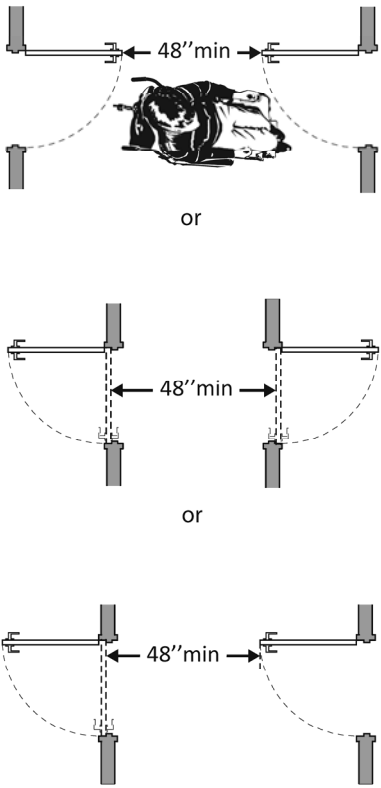
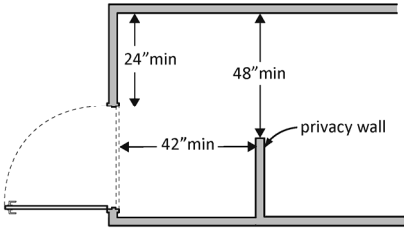
*If constructed before 3/15/2010 and a person may approach within 3 inches of the sign without encountering protruding objects or standing within the door swing, relocation not required

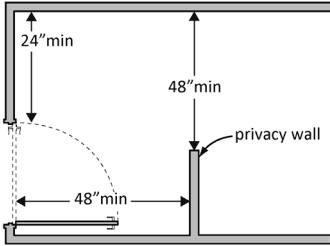

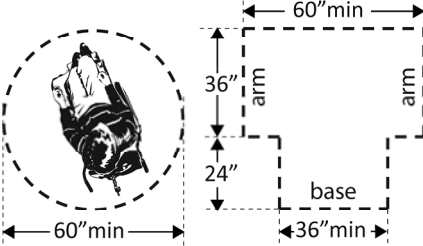
*If constructed before 3/15/2012 and mounted no higher than 60 inches to the centerline of the sign, relocation is not required

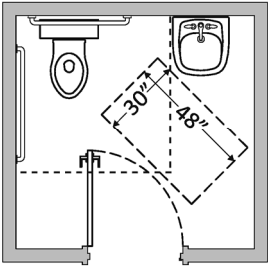
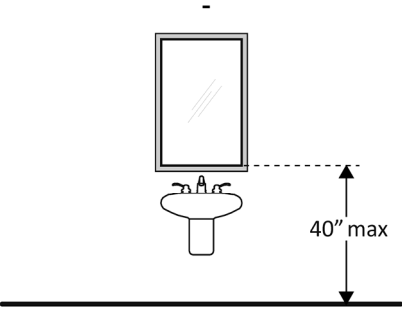
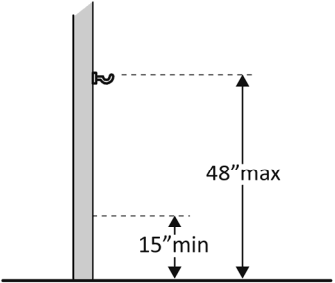
Photo #:

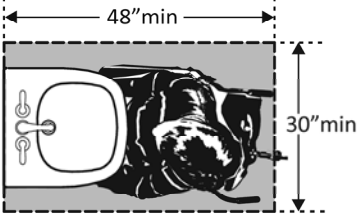
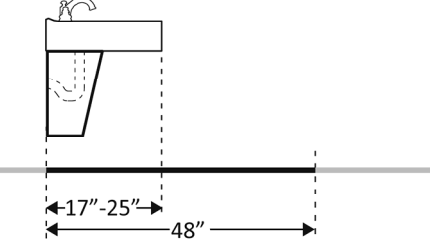
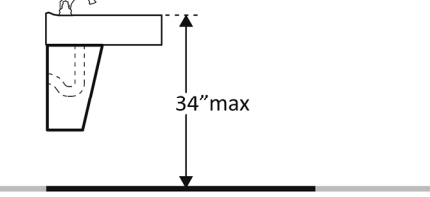
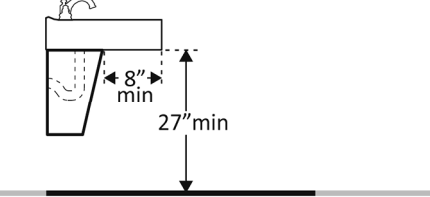
<p>should be on the wall to the right of the right leaf.</p>				
<p>Entrance (2010 Standards – 404)</p>				
<p>3.6 Is the door opening width at least 32 inches clear, between the face of the door and the stop, when the door is open 90 degrees?</p>	<p><input checked="" type="checkbox"/> Yes <input type="checkbox"/> No</p> <p>Measurement:</p> <p>32"</p>		<p>NA</p> <p>Photo #:</p>	<ul style="list-style-type: none"> • Install offset hinges • Alter the doorway •
<p>3.7 If there is a front approach to the pull side of the door is there at least 18 inches of maneuvering clearance beyond the latch side plus 60 inches clear depth?</p> <p>On both sides of the door, is the floor surface of the maneuvering clearance level (no steeper than 1:48)?</p>	<p><input type="checkbox"/> Yes <input checked="" type="checkbox"/> No</p> <p>Measurement:</p> <p>14" SIDE 48" FRONT</p> <p><input checked="" type="checkbox"/> Yes <input type="checkbox"/> No</p> <p>Measurement:</p>		<p>NA</p> <p>Photo #:</p>	<ul style="list-style-type: none"> • Remove obstructions • Reconfigure walls • Add automatic door opener <p>See 2010 Standards 404.2.4 for maneuvering clearance requirements on the push side of the door and side approaches to the pull side of the door</p>
<p>3.8 Is the door threshold edge no more than ¼ inch high?</p> <p>Or</p> <p>No more than ¾ inch high if slope is beveled no steeper than 1:2?</p> <p>Note: The first ¼ inch of the threshold may be vertical; the rest must be beveled.</p>	<p><input type="checkbox"/> Yes <input type="checkbox"/> No</p> <p>Measurement:</p> <p><input type="checkbox"/> Yes <input type="checkbox"/> No</p> <p>Measurement:</p>		<p>NA</p> <p>Photo #:</p>	<ul style="list-style-type: none"> • Remove or replace threshold • •

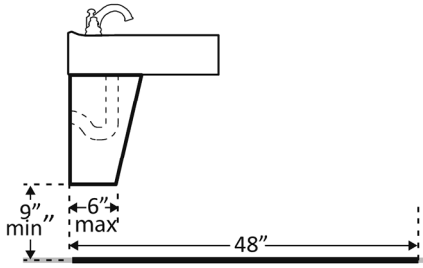
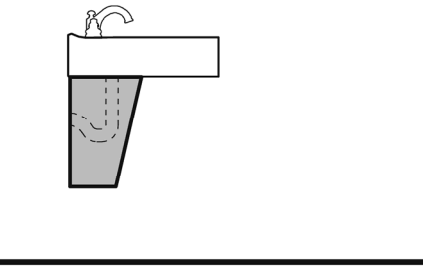
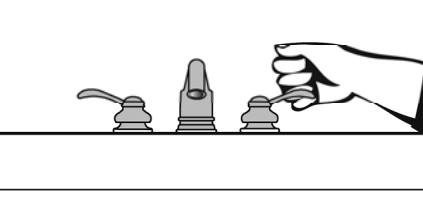
<p>3.9 Is the door equipped with hardware that is operable with one hand and does not require tight grasping, pinching, or twisting of the wrist? Check door handle and lock (if provided).</p>	<p><input checked="" type="checkbox"/> Yes <input type="checkbox"/> No</p> <p>Measurement: 41" BOTTOM 51" TOP</p>		<p>Photo #: 3.11</p>	<ul style="list-style-type: none"> • Replace knobs or latches with lever or loop handles • Install power-assisted or automatic door openers •
<p>3.10 Are the operable parts of the door hardware mounted no less than 34 inches and no greater than 48 inches above the floor?</p>	<p><input type="checkbox"/> Yes <input checked="" type="checkbox"/> No</p> <p>Measurement: 41" BOTTOM 51" TOP</p>		<p>Photo #: 3.11</p>	<ul style="list-style-type: none"> • Change hardware height • •
<p>3.11 Can the door be opened easily (5 pounds maximum force)?</p>	<p><input type="checkbox"/> Yes <input checked="" type="checkbox"/> No</p> <p>Measurement: 7 LB</p>		<p>Photo # 3.11</p>	<ul style="list-style-type: none"> • Adjust or replace closers • Install lighter doors • Install power-assisted or automatic door openers
<p>3.12 If the door has a closer, does it take at least 5 seconds to close from an open position of 90 degrees to a position of 12 degrees from the latch?</p>	<p><input checked="" type="checkbox"/> Yes <input type="checkbox"/> No</p> <p>Measurement: 5 SEC.</p>		<p>Photo #: 3.11</p>	<ul style="list-style-type: none"> • Adjust closer • •

<p>3.13 If there are two doors in a series, e.g. vestibule, is the distance between the doors at least 48 inches plus the width of the doors when swinging into the space?</p>	<p><input type="checkbox"/> Yes <input type="checkbox"/> No</p> <p>Measurement:</p>		<p style="text-align: center; color: red; font-weight: bold;">NA</p> <p>Photo #:</p>	<ul style="list-style-type: none"> • Remove inner door • Change door swing •
<p>3.14 If there is a privacy wall and the door swings out, is there at least 24 inches of maneuvering clearance beyond the door latch side and 42 inches to the privacy wall?</p>	<p><input type="checkbox"/> Yes <input type="checkbox"/> No</p> <p>Measurement:</p>		<p style="text-align: center; color: red; font-weight: bold;">NA</p> <p>Photo #:</p>	<ul style="list-style-type: none"> • Reconfigure space • •

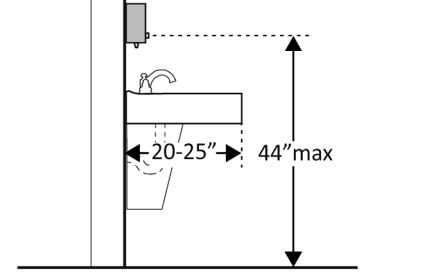
<p>3.15 If there is a privacy wall and the door swings in, is there at least 24 inches of maneuvering clearance beyond the door latch side and at least 48 inches to the privacy wall if there is no door closer or at least 54 inches if there is a door closer?</p>	<p><input type="checkbox"/> Yes <input type="checkbox"/> No</p> <p>Measurement:</p>		<p style="text-align: center; color: red; font-weight: bold;">NA</p> <p>Photo #:</p>	<ul style="list-style-type: none"> • Reconfigure space • •
In the Toilet Room				
<p>3.16 Is there a clear path to at least one of each type of fixture, e.g. lavatory, hand dryer, etc., that is at least 36 inches wide?</p>	<p><input checked="" type="checkbox"/> Yes <input type="checkbox"/> No</p> <p>Measurement:</p> <p style="color: red; font-weight: bold; text-align: center;">47"</p>		<p>Photo #: 3.17</p>	<ul style="list-style-type: none"> • Remove obstructions • •
<p>3.17 Is there clear floor space available for a person in a wheelchair to turn around, i.e. a circle at least 60 inches in diameter or a T-shaped space within a 60-inch square?*</p>	<p><input checked="" type="checkbox"/> Yes <input type="checkbox"/> No</p> <p>Measurement:</p> <p style="color: red; font-weight: bold; text-align: center;">60" x 111"</p>		<p>Photo #: 3.17</p>	<p>*The door to the toilet room may swing into the required turning space</p> <ul style="list-style-type: none"> • Move or remove partitions, fixtures or objects such as trash cans • •

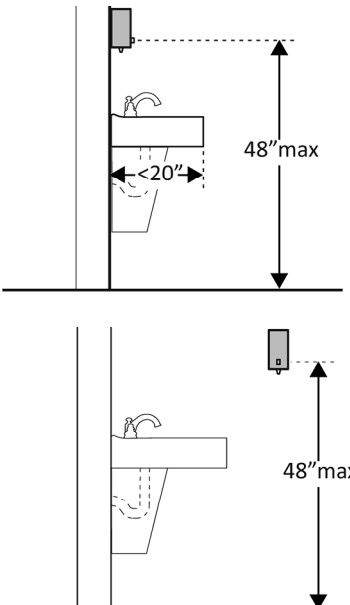
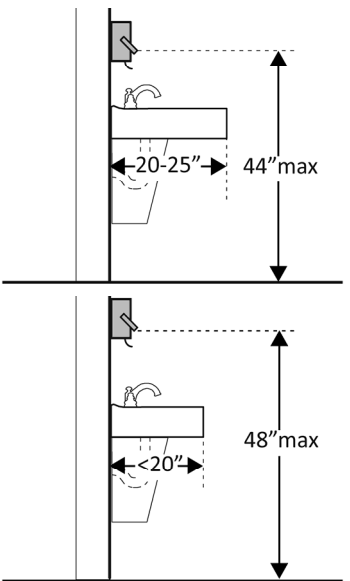
<p>3.18 In a single user toilet room if the door swings in and over a clear floor space at an accessible fixture, is there a clear floor space at least 30 x 48 inches beyond the swing of the door?</p>	<p><input type="checkbox"/> Yes <input type="checkbox"/> No</p> <p>Measurement:</p>		<p style="text-align: center;">NA</p> <p>Photo #:</p>	<ul style="list-style-type: none"> • Reverse door swing • Alter toilet room •
<p>3.19 If the mirror is over a lavatory or countertop, is the bottom edge of the reflecting surface no higher than 40 inches above the floor? Or If the mirror is not over the lavatory or countertop, is the bottom edge of the reflecting surface no higher than 35 inches above the floor?*</p>	<p><input checked="" type="checkbox"/> Yes <input type="checkbox"/> No</p> <p>Measurement:</p> <p style="text-align: center;">39 ½"</p> <p><input type="checkbox"/> Yes <input type="checkbox"/> No</p> <p>Measurement:</p> <p style="text-align: center;">NA</p>		<p>Photo #: 3.19</p>	<p>* If installed before 3/15/2012 and the bottom edge of the reflecting surface is no higher than 40 inches above the floor, lowering the mirror to 35 inches is not required</p> <ul style="list-style-type: none"> • Lower the mirror • Add another mirror •
<p>3.20 If there is a coat hook, is it no less than 15 inches and no greater than 48 inches above the floor?</p>	<p><input type="checkbox"/> Yes <input checked="" type="checkbox"/> No</p> <p>Measurement:</p> <p style="text-align: center;">62"</p>		<p>Photo #: 3.20</p>	<ul style="list-style-type: none"> • Adjust hook • Replace with or provide additional accessible hook •

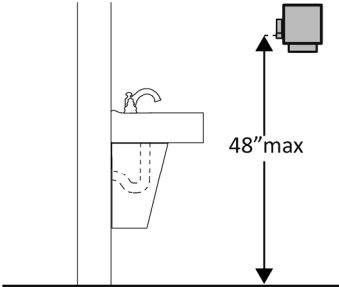
Lavatories (2010 Standards – 606) Note: 2010 Standards refer to sinks in toilet rooms as lavatories.				
<p>3.21 Does at least one lavatory have a clear floor space for a forward approach at least 30 inches wide and 48 inches long?</p>	<p><input checked="" type="checkbox"/> Yes <input type="checkbox"/> No</p> <p>Measurement:</p> <p>30" x 60"</p>		<p>Photo #: 3.17</p>	<ul style="list-style-type: none"> • Alter lavatory • Replace lavatory •
<p>3.22 Do no less than 17 inches and no greater than 25 inches of the clear floor space extend under the lavatory so that a person using a wheelchair can get close enough to reach the faucet?</p>	<p><input checked="" type="checkbox"/> Yes <input type="checkbox"/> No</p> <p>Measurement:</p> <p>17"</p>		<p>Photo #: 3.22</p>	<ul style="list-style-type: none"> • Alter lavatory • Replace lavatory •
<p>3.23 Is the front of the lavatory or counter surface, whichever is higher, no more than 34 inches above the floor?</p>	<p><input checked="" type="checkbox"/> Yes <input type="checkbox"/> No</p> <p>Measurement:</p> <p>32 1/2"</p>		<p>Photo #: 3.22</p>	<ul style="list-style-type: none"> • Alter lavatory • Replace lavatory •
<p>3.24 Is there at least 27 inches clearance from the floor to the bottom of the lavatory that extends at least 8 inches under the lav for knee clearance?</p>	<p><input checked="" type="checkbox"/> Yes <input type="checkbox"/> No</p> <p>Measurement:</p> <p>28 1/2"</p>		<p>Photo #: 3.22</p>	<ul style="list-style-type: none"> • Alter lavatory • Replace lavatory •

<p>3.25 Is there toe clearance at least 9 inches high? (Space extending greater than 6 inches beyond the available toe clearance at 9 inches above the floor is not considered toe clearance.)</p>	<p><input checked="" type="checkbox"/> Yes <input type="checkbox"/> No 13"</p>		<p>Photo #: 3.22</p>	<ul style="list-style-type: none"> • Alter lavatory • Replace lavatory •
<p>3.26 Are pipes below the lavatory insulated or otherwise configured to protect against contact?</p>	<p><input type="checkbox"/> Yes <input checked="" type="checkbox"/> No</p>		<p>Photo #: 3.22</p>	<ul style="list-style-type: none"> • Install insulation • Install cover panel •
<p>3.27 Can the faucet be operated without tight grasping, pinching, or twisting of the wrist? Is the force required to activate the faucet no greater than 5 pounds?</p>	<p><input type="checkbox"/> Yes <input type="checkbox"/> No <input type="checkbox"/> Yes <input type="checkbox"/> No</p>		<p>NA – SENSOR OPERATED</p> <p>Photo #:</p>	<ul style="list-style-type: none"> • Adjust faucet • Replace faucet •

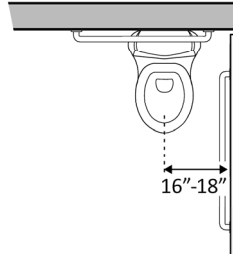
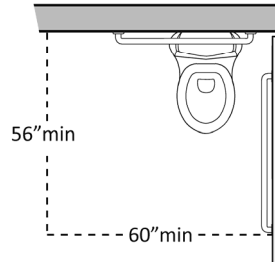
Soap Dispensers and Hand Dryers (2010 Standards – 603)

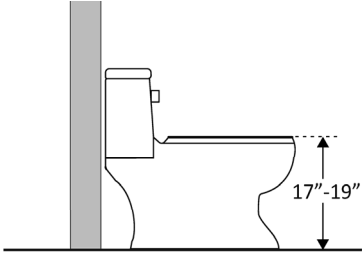
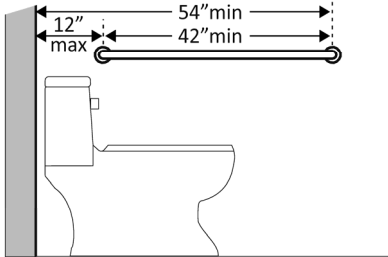
<p>3.28 Are the operable parts of the soap dispenser within one of the following reach ranges: Above lavatories or counters no less than 20 inches and no greater than 25 inches deep; no higher than 44 inches above the floor?</p>	<p><input type="checkbox"/> Yes <input checked="" type="checkbox"/> No Measurement: 52"</p>		<p>Photo #:</p>	<ul style="list-style-type: none"> • Adjust dispensers • Replace with or provide additional accessible dispensers •
--	---	--	-----------------	--

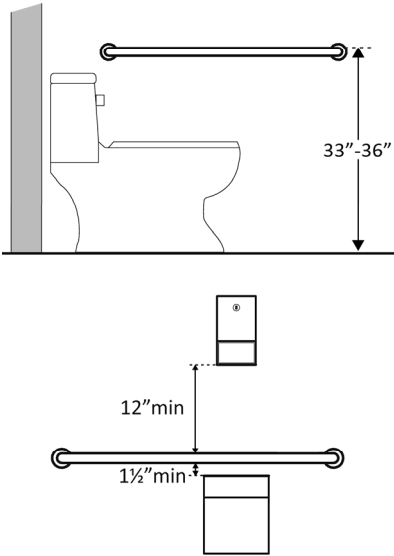
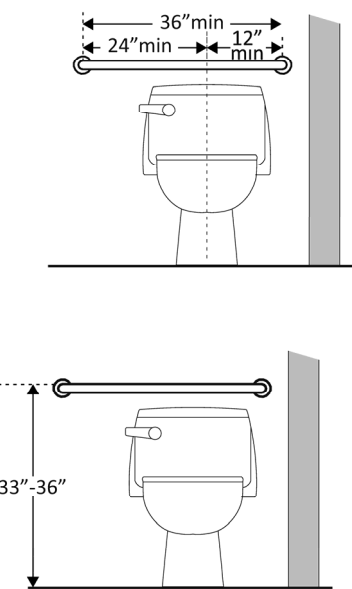
<p>Above lavatories less than 20 inches deep: no higher than 48 inches above the floor?</p> <p>Not over an obstruction: no higher than 48 inches above the floor?</p>	<p><input type="checkbox"/> Yes <input type="checkbox"/> No Measurement: NA</p> <p><input type="checkbox"/> Yes <input checked="" type="checkbox"/> No Measurement: 52"</p>		<p>Photo #: 3.19</p>	
<p>3.29 Are the operable parts of the hand dryer or towel dispenser within one of the following reach ranges:</p> <p>Above lavatories or counters no less than 20 inches and no greater than 25 inches deep: no higher than 44 inches above the floor?</p> <p>Above lavatories less than 20 inches deep: no higher than 48 inches above the floor?</p> <p>Not over an obstruction: no higher than 48 inches above the floor?</p>	<p><input type="checkbox"/> Yes <input type="checkbox"/> No Measurement: NA</p> <p><input type="checkbox"/> Yes <input type="checkbox"/> No Measurement: NA</p> <p><input checked="" type="checkbox"/> Yes <input type="checkbox"/> No Measurement: 48"</p>			<ul style="list-style-type: none"> • Adjust dispensers • Replace with or provide additional accessible dispensers •

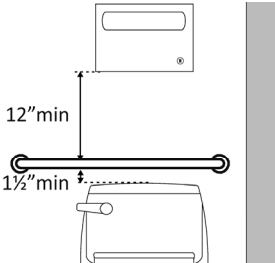
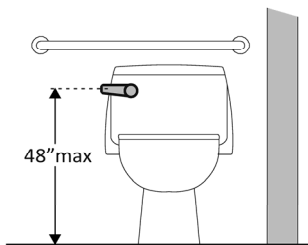
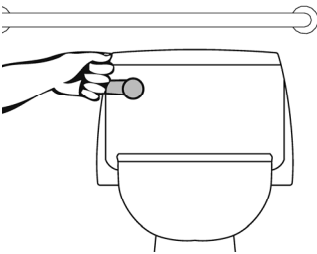
<p>Can the operable parts of the hand dryer or towel dispenser be operated without tight grasping, pinching or twisting of the wrist?</p> <p>Is the force required to activate the hand dryer or towel dispenser no greater than 5 pounds?</p>	<p><input checked="" type="checkbox"/> Yes <input type="checkbox"/> No</p> <p>48"</p> <p><input checked="" type="checkbox"/> Yes <input type="checkbox"/> No</p> <p>Measurement: 5lbs</p>		<p>Photo #: 3.29</p>	
--	---	--	-----------------------------	--

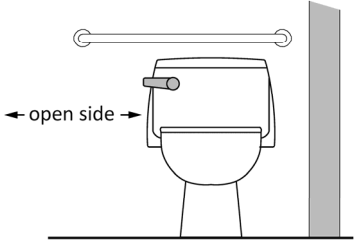
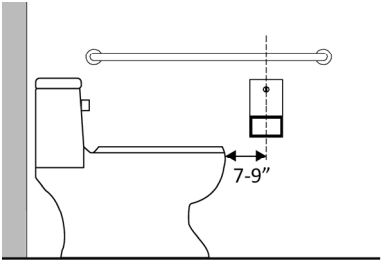
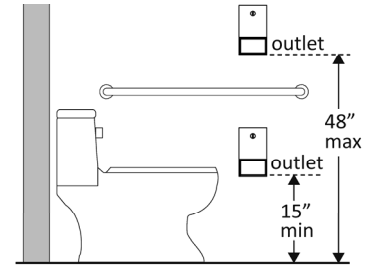
Water Closets in Single-User Toilet Rooms and Compartments (Stalls) (2010 Standards – 603 & 609) Note: 2010 Standards refer to toilets as water closets.

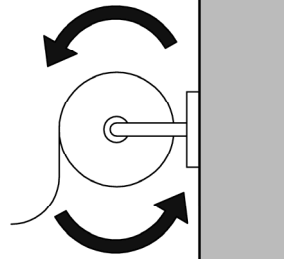
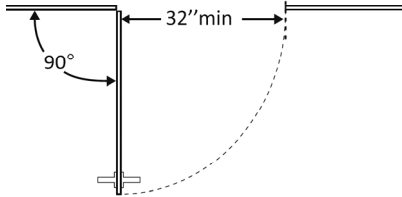
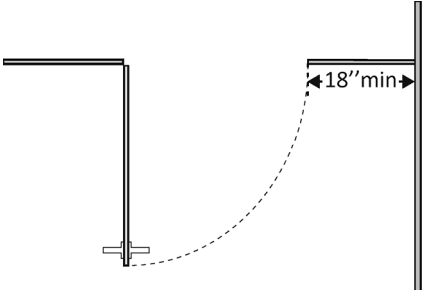
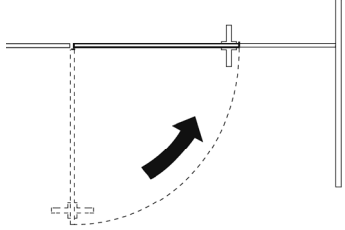
<p>3.30 Is the centerline of the water closet no less than 16 inches and no greater than 18 inches from the side wall or partition?</p>	<p><input type="checkbox"/> Yes <input checked="" type="checkbox"/> No</p> <p>Measurement: 20"</p>		<p>Photo #: 3.30</p>	<ul style="list-style-type: none"> • Move toilet • Replace toilet • Move partition •
<p>3.31 Is clearance provided around the water closet measuring at least 60 inches from the side wall and at least 56 inches from the rear wall?*</p>	<p><input type="checkbox"/> Yes <input checked="" type="checkbox"/> No</p> <p>Measurement: 20"</p>		<p>Photo #: 3.30</p>	<p>* If constructed before 3/15/12, clearances around water closets in single user toilet rooms can be 48 inches wide by 66 inches long or 48 inches wide by 56 inches long (depending on the approach to the water closet, see 1991 Standards Figure 28) and the lavatory may overlap that clearance if the door to the room does not swing into the</p>

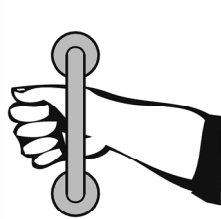
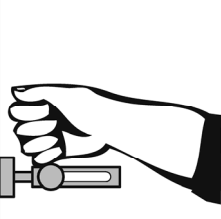
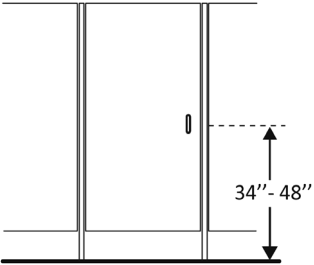
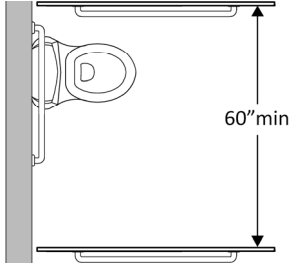
				<p>required clearances at fixtures (such as lavatories, water closet and urinals) and the edge of the lavatory is at least 18 inches from the centerline of the water closet</p> <ul style="list-style-type: none"> Alter room/compartment for clearance
<p>3.32 Is the height of the water closet no less than 17 inches and no greater than 19 inches above the floor measured to the top of the seat?</p>	<p><input checked="" type="checkbox"/> Yes <input type="checkbox"/> No</p> <p>Measurement:</p> <p>19"</p>		<p>Photo #: 3.30</p>	<ul style="list-style-type: none"> Adjust toilet height Replace toilet
<p>3.33 Is there a grab bar at least 42 inches long on the side wall?</p> <p>Is it located no more than 12 inches from the rear wall?</p> <p>Does it extend at least 54 inches from the rear wall?</p> <p>Is it mounted no less than 33 inches and no greater than 36 inches above the floor to the top of the gripping surface?</p>	<p><input type="checkbox"/> Yes <input checked="" type="checkbox"/> No</p> <p>Measurement:</p> <p>24"</p> <p><input checked="" type="checkbox"/> Yes <input type="checkbox"/> No</p> <p>Measurement:</p> <p>6"</p> <p><input type="checkbox"/> Yes <input checked="" type="checkbox"/> No</p> <p>Measurement:</p> <p>24"</p> <p><input checked="" type="checkbox"/> Yes <input type="checkbox"/> No</p> <p>Measurement:</p> <p>33"</p>			<ul style="list-style-type: none"> Install grab bar Relocate grab bar Relocate objects

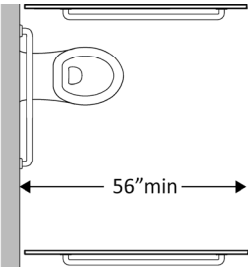
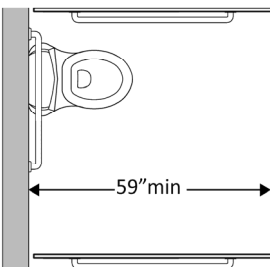
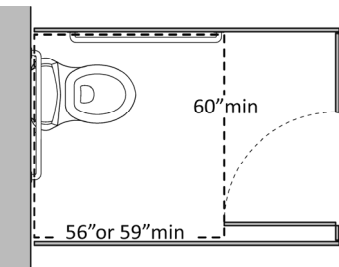
<p>Is there at least 12 inches clearance between the grab bar and protruding objects above?*</p> <p>Is there at least 1½ inches clearance between the grab bar and projecting objects below?*</p> <p>Is the space between the wall and the grab bar 1 ½ inches?</p>	<p><input type="checkbox"/> Yes <input checked="" type="checkbox"/> No Measurement: 8"</p> <p><input checked="" type="checkbox"/> Yes <input type="checkbox"/> No Measurement: NO PROTRUDING OBJECTS BELOW</p> <p><input checked="" type="checkbox"/> Yes <input type="checkbox"/> No Measurement: 8"</p>		<p>Photo #: 3.30</p>	<p>* If constructed before 3/15/2012 grab bars do not need to be relocated; there are no space requirements above and below grab bars in the 1991 Standards</p>
<p>3.34 Is there a grab bar at least 36 inches long on the rear wall?</p> <p>Does it extend at least 12 inches from the centerline of the water closet on one side (side wall)?</p> <p>Does it extend at least 24 inches on the other (open) side?</p> <p>Is it mounted no less than 33 inches and no greater than 36 inches above the floor to the top of the gripping surface?</p> <p>Are there at least 12 inches clearance between the grab bar and protruding objects above?*</p>	<p><input type="checkbox"/> Yes <input checked="" type="checkbox"/> No Measurement: 24"</p> <p><input checked="" type="checkbox"/> Yes <input type="checkbox"/> No Measurement: 12"</p> <p><input type="checkbox"/> Yes <input checked="" type="checkbox"/> No Measurement: 12"</p> <p><input checked="" type="checkbox"/> Yes <input type="checkbox"/> No Measurement: 33"</p> <p><input checked="" type="checkbox"/> Yes <input type="checkbox"/> No Measurement: NO PROTRUDING OBJECTS BELOW</p>		<p>Photo #: 3.34</p> <p>Photo #:</p>	<ul style="list-style-type: none"> • Install grab bar • Relocate grab bar • Relocate objects •

<p>Are there at least 1½ inches clearance between the grab bar and projecting objects below?*</p> <p>Is the space between the wall and the grab bar 1 ½ inches?</p>	<p><input checked="" type="checkbox"/> Yes <input type="checkbox"/> No</p> <p>Measurement: NO PROTRUDING OBJECTS</p> <p><input type="checkbox"/> Yes <input type="checkbox"/> No</p> <p>Measurement: 5 ½"</p>		<p>Photo #:</p>	<p>* If constructed before 3/15/2012 grab bars do not need to be relocated; there are no space requirements above and below grab bars in the 1991 Standards</p>
<p>3.35 If the flush control is hand operated, is the operable part located no higher than 48 inches above the floor?</p>	<p><input type="checkbox"/> Yes <input type="checkbox"/> No</p> <p>Measurement:</p>		<p>Photo #:</p> <p style="text-align: center;">NA</p>	<ul style="list-style-type: none"> • Move control • Install sensor with override button no higher than 48 inches •
<p>3.36 If the flush control is hand operated, can it be operated with one hand and without tight grasping, pinching, or twisting of the wrist?</p> <p>Is the force required to activate the flush control no greater than 5 pounds?</p>	<p><input type="checkbox"/> Yes <input type="checkbox"/> No</p> <p><input type="checkbox"/> Yes <input type="checkbox"/> No</p> <p>Measurement:</p>		<p>Photo #:</p> <p style="text-align: center;">NA</p>	<ul style="list-style-type: none"> • Change control • Adjust control •

<p>3.37 Is the flush control on the open side of the water closet?</p>	<p><input type="checkbox"/> Yes <input checked="" type="checkbox"/> No</p> <p>20"</p>		<p>Photo #: 3.30</p>	<ul style="list-style-type: none"> • Move control • •
<p>3.38 Is the toilet paper dispenser located no less than 7 inches and no greater than 9 inches from the front of the water closet to the centerline of the dispenser?*</p>	<p><input type="checkbox"/> Yes <input checked="" type="checkbox"/> No</p> <p>Measurement:</p> <p>15"</p>		<p>Photo #: 3.38</p>	<p>* If constructed before 3/15/2012 dispenser does not need to be relocated if it is within reach from the water closet seat; the 1991 Standards do not specify distance from the front of the water closet</p> <ul style="list-style-type: none"> • Relocate dispenser • •
<p>3.39 Is the outlet of the dispenser:</p> <p>Located no less than 15 inches and no greater than 48 inches above the floor?</p> <p>Not located behind grab bars?</p>	<p><input checked="" type="checkbox"/> Yes <input type="checkbox"/> No</p> <p>Measurement:</p> <p>29 ½"</p> <p><input checked="" type="checkbox"/> Yes <input type="checkbox"/> No</p>		<p>Photo #: 3.39</p>	<ul style="list-style-type: none"> • Relocate dispenser • •

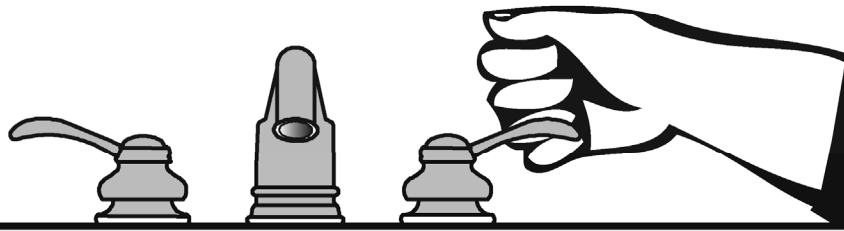
<p>3.40 Does the dispenser allow continuous paper flow?</p>	<p><input checked="" type="checkbox"/> Yes <input type="checkbox"/> No</p>		<p>Photo 3.39</p>	<ul style="list-style-type: none"> • Adjust dispenser • Replace dispenser •
<p>Toilet Compartments (Stalls) (2010 Standards – 604)</p>				
<p>3.41 Is the door opening width at least 32 inches clear, between the face of the door and the stop, when the door is open 90 degrees?</p>	<p><input checked="" type="checkbox"/> Yes <input type="checkbox"/> No</p> <p>Measurement: 32"</p>		<p>Photo #: 3.41</p>	<ul style="list-style-type: none"> • Widen door width • •
<p>3.42 If there is a front approach to the pull side of the door, is there at least 18 inches of maneuvering clearance beyond the latch side plus 60 inches clear depth?*</p>	<p><input type="checkbox"/> Yes <input checked="" type="checkbox"/> No</p> <p>Measurement: 6"</p>		<p>Photo #: 3.41</p>	<p>*See 2010 Standards 604.8.1.2 Doors for maneuvering clearance requirements on the push side of the door and side approaches to the pull side of the door</p> <ul style="list-style-type: none"> • Remove obstructions •
<p>3.43 Is the door self-closing?</p>	<p><input type="checkbox"/> Yes <input checked="" type="checkbox"/> No</p>		<p>Photo #: 3.43</p>	<ul style="list-style-type: none"> • Add closer • Replace door •

<p>3.44 Are there door pulls on both sides of the door that are operable with one hand and do not require tight grasping pinching or twisting of the wrist?*</p>	<p><input type="checkbox"/> Yes <input checked="" type="checkbox"/> No</p>		<p>Photo #: 3.41</p>	<p>* If constructed before 3/15/2012 door pulls do not need to be added; door pulls are not required in the 1991 Standards</p> <ul style="list-style-type: none"> • Replace hardware • •
<p>3.45 Is the lock operable with one hand and without tight grasping, pinching or twisting of the wrist?</p>	<p><input checked="" type="checkbox"/> Yes <input type="checkbox"/> No</p>		<p>Photo #: 3.41</p>	<ul style="list-style-type: none"> • Replace lock • •
<p>3.46 Are the operable parts of the door hardware mounted no less than 34 inches and no greater than 48 inches above the floor?</p>	<p><input checked="" type="checkbox"/> Yes <input type="checkbox"/> No</p> <p>Measurement:</p> <p>41"</p>		<p>Photo #: 3.41</p>	<ul style="list-style-type: none"> • Relocate hardware • •
<p>3.47 Is the compartment at least 60 inches wide?</p>	<p><input type="checkbox"/> Yes <input checked="" type="checkbox"/> No</p> <p>Measurement:</p> <p>38"</p>		<p>Photo #: 3.3</p>	<ul style="list-style-type: none"> • Widen compartment • •

<p>3.48 If the water closet is wall hung, is the compartment at least 56 inches deep?</p>	<p><input checked="" type="checkbox"/> Yes <input type="checkbox"/> No</p> <p>Measurement:</p> <p>65"</p>		<p>Photo #: 3.3</p>	<ul style="list-style-type: none"> • Widen compartment • •
<p>3.49 If the water closet is floor mounted, is the compartment at least 59 inches deep?</p>	<p><input type="checkbox"/> Yes <input type="checkbox"/> No</p> <p>Measurement:</p>		<p>Photo #: NA</p>	<ul style="list-style-type: none"> • Alter compartment • •
<p>3.50 If the door swings in, is the minimum required compartment area provided beyond the swing of the door (60 inches x 56 inches if water closet is wall hung or 59 inches if water closet is floor mounted)?</p>	<p><input type="checkbox"/> Yes <input type="checkbox"/> No</p> <p>Measurement:</p>		<p>Photo #: NA</p>	<ul style="list-style-type: none"> • Reverse door swing • Alter compartment •
	<p><input type="checkbox"/> Yes <input type="checkbox"/> No</p>		<p>Photo #:</p>	<ul style="list-style-type: none"> • • •
	<p><input type="checkbox"/> Yes <input type="checkbox"/> No</p>		<p>Photo #:</p>	<ul style="list-style-type: none"> • • •

The ADA Checklist for Readily Achievable Barrier Removal

Priority 3 – Women’s Toilet Rooms



Project **SDDOT Rest Area Improvements**
FHU Reference Number 13-039-01
TSP Project Number 03120855

Building **HOMESTEAD**

Location **29 N/S., MRM 26**

Date **09-17-2013 (Inspection)**

Surveyors **Timothy Roach, AIA**
Todd Schultz, PE

Robert King, CPD

Contact Information **TSP – (605) 343-6102**



When toilet rooms are open to the public they should be accessible to people with disabilities.



Institute for Human Centered Design
www.HumanCenteredDesign.org
November 2011



ADA National Network
Questions on the ADA 800-949-4232 voice/tty
www.ADAchecklist.org

Priority 3 – Toilet Rooms		Comments	Possible Solutions
<p>3.1 If toilet rooms are available to the public, is at least one toilet room accessible? (Either one for each sex, or one unisex.)</p>	<input checked="" type="checkbox"/> Yes <input type="checkbox"/> No	<p>Photo #:</p>	<ul style="list-style-type: none"> • Reconfigure toilet rooms • Combine toilet rooms to create one unisex accessible toilet room
<p>3.2 Are there signs at inaccessible toilet rooms that give directions to accessible toilet rooms?</p>	<input type="checkbox"/> Yes <input type="checkbox"/> No	 <p>Photo #:</p>	<p>NA</p> <ul style="list-style-type: none"> • Install signs • •
<p>3.3 If not all toilet rooms are accessible, is there a sign at the accessible toilet room with the International Symbol of Accessibility?</p>	<input type="checkbox"/> Yes <input type="checkbox"/> No	 <p>Photo #:</p>	<p>NA</p> <ul style="list-style-type: none"> • Install sign • •
<p>Accessible Route (2010 Standards – Chapter 4)</p>			
<p>3.4 Is there a route to the accessible toilet room(s) that does not include the use of stairs?</p>	<input checked="" type="checkbox"/> Yes <input type="checkbox"/> No		<ul style="list-style-type: none"> • Alter route • •
<p>Is the route accessible? (See Priority 2 Interior Accessible Route for specifics.)</p>	<input checked="" type="checkbox"/> Yes <input type="checkbox"/> No	<p>Photo #: 3.4</p>	

Signs at Toilet Rooms (2010 Standards – 703)

3.5 Do text characters contrast with their backgrounds?

Yes No

Are text characters raised?

Yes No

Is there Braille?

Yes No

Is the sign mounted:
On the wall on the latch side of the door?

Yes No

Note:

Signs are permitted on the push side of doors with closers and without hold-open devices.

With clear floor space beyond the arc of the door swing and 45-degree open position, at least 18 x 18 inches centered on the tactile characters? *

Yes No

Measurement:

NA

So the baseline of the lowest character is at least 48 inches above the floor and the baseline of the highest character is no more than 60 inches above the floor? *

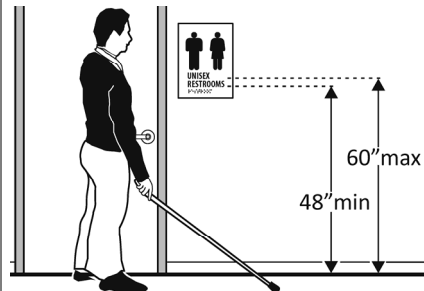
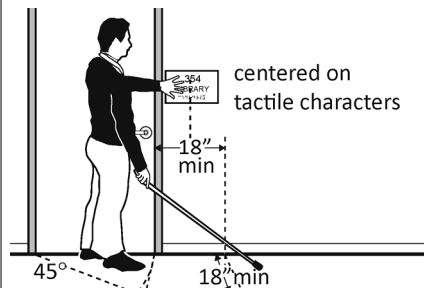
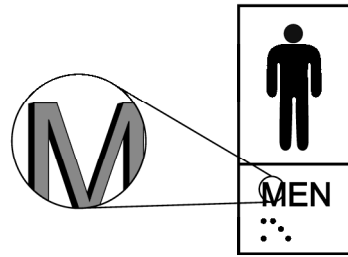
Yes No

Measurement:

NA

Note:

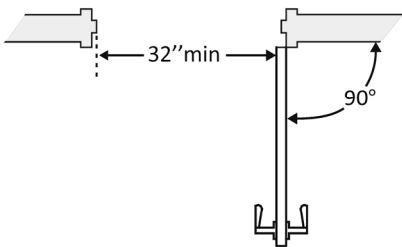
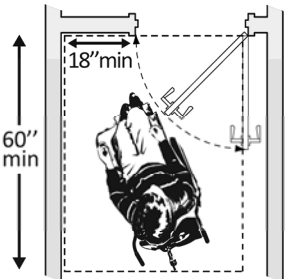
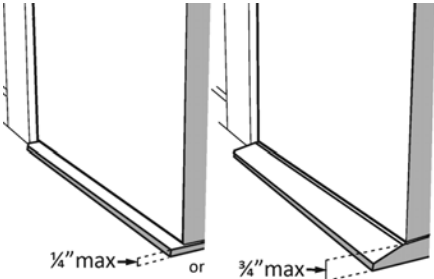
If the sign is at double doors with one active leaf, the sign should be on the inactive leaf; if both leaves are active, the sign

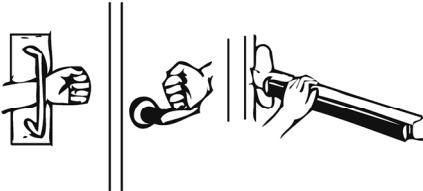
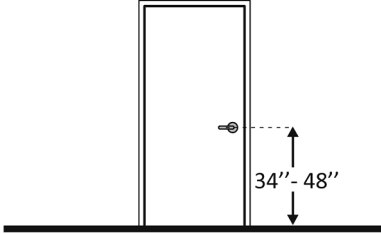

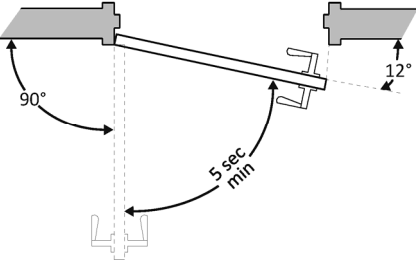


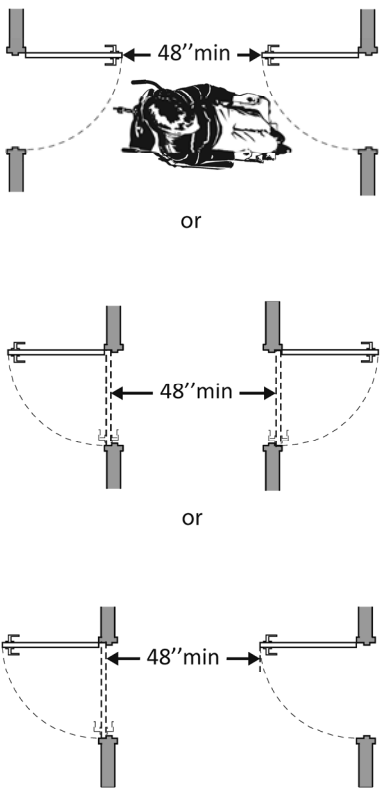
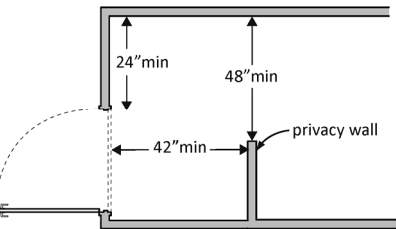
- Install tactile sign
- Relocate sign
-

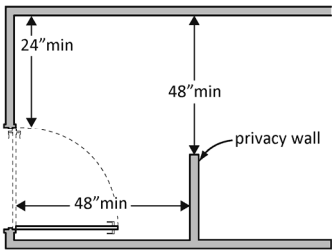

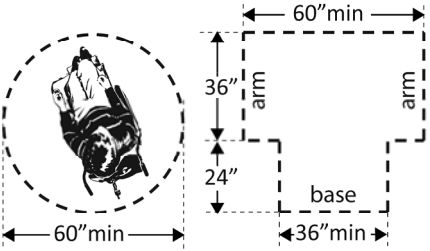
*If constructed before 3/15/2010 and a person may approach within 3 inches of the sign without encountering protruding objects or standing within the door swing, relocation not required

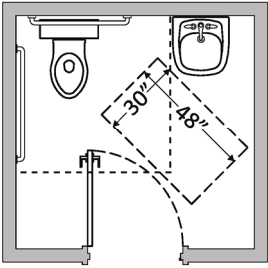
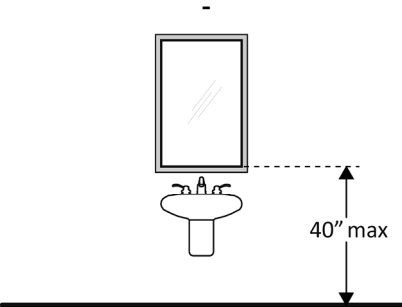
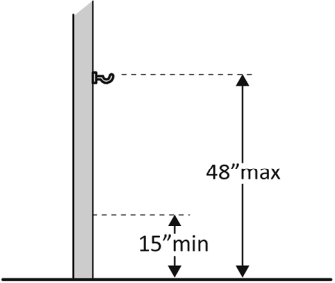
*If constructed before 3/15/2012 and mounted no higher than 60 inches to the centerline of the sign, relocation is not required

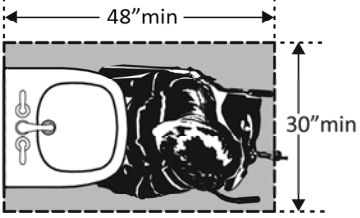
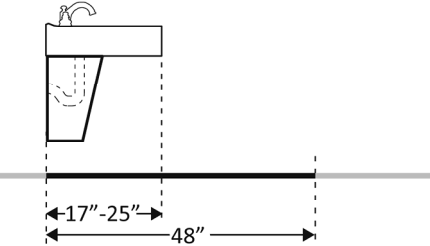
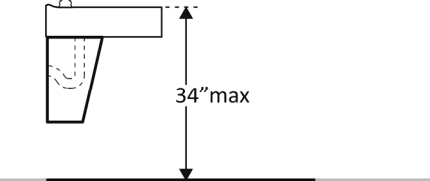
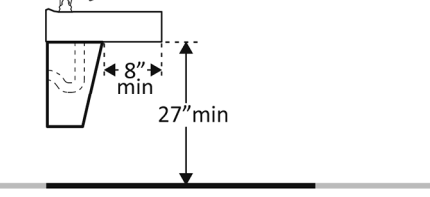
<p>should be on the wall to the right of the right leaf.</p>			<p>Photo #: 3.5</p>	
<p>Entrance (2010 Standards – 404)</p>				
<p>3.6 Is the door opening width at least 32 inches clear, between the face of the door and the stop, when the door is open 90 degrees?</p>	<p><input checked="" type="checkbox"/> Yes <input type="checkbox"/> No Measurement: 32"</p>		<p>Photo #: 3.6</p>	<ul style="list-style-type: none"> • Install offset hinges • Alter the doorway •
<p>3.7 If there is a front approach to the pull side of the door is there at least 18 inches of maneuvering clearance beyond the latch side plus 60 inches clear depth?</p> <p>On both sides of the door, is the floor surface of the maneuvering clearance level (no steeper than 1:48)?</p>	<p><input type="checkbox"/> Yes <input checked="" type="checkbox"/> No Measurement: 14" SIDE 48" FRONT</p> <p><input type="checkbox"/> Yes <input type="checkbox"/> No Measurement:</p>		<p>Photo #: 3.7</p>	<ul style="list-style-type: none"> • Remove obstructions • Reconfigure walls • Add automatic door opener <p>See 2010 Standards 404.2.4 for maneuvering clearance requirements on the push side of the door and side approaches to the pull side of the door</p>
<p>3.8 Is the door threshold edge no more than ¼ inch high? Or No more than ¾ inch high if slope is beveled no steeper than 1:2? Note: The first ¼ inch of the threshold may be vertical; the rest must be beveled.</p>	<p><input type="checkbox"/> Yes <input type="checkbox"/> No Measurement:</p> <p><input type="checkbox"/> Yes <input type="checkbox"/> No Measurement:</p>		<p>NA</p> <p>Photo #:</p>	<ul style="list-style-type: none"> • Remove or replace threshold • •

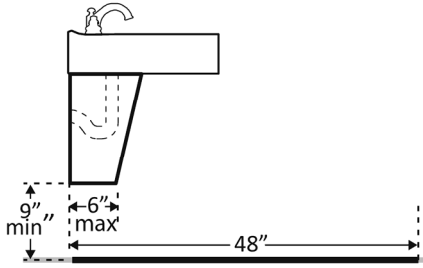
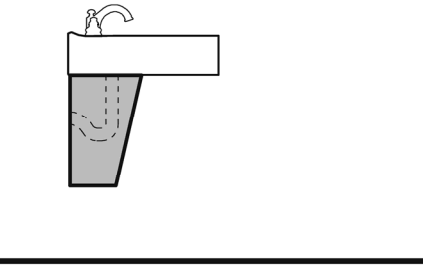
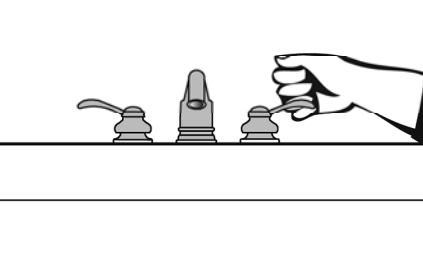
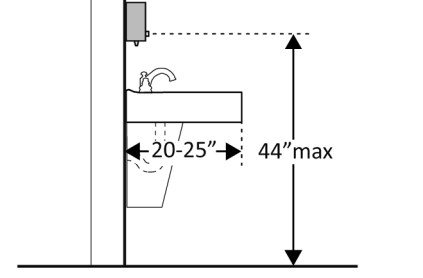
<p>3.9 Is the door equipped with hardware that is operable with one hand and does not require tight grasping, pinching, or twisting of the wrist? Check door handle and lock (if provided).</p>	<p><input checked="" type="checkbox"/> Yes <input type="checkbox"/> No</p> <p>Measurement:</p>		<p>Photo #:</p>	<ul style="list-style-type: none"> • Replace knobs or latches with lever or loop handles • Install power-assisted or automatic door openers •
<p>3.10 Are the operable parts of the door hardware mounted no less than 34 inches and no greater than 48 inches above the floor?</p>	<p><input type="checkbox"/> Yes <input checked="" type="checkbox"/> No</p> <p>Measurement: 41" Bottom 51" Top</p>		<p>Photo #: 3.10</p>	<ul style="list-style-type: none"> • Change hardware height • •
<p>3.11 Can the door be opened easily (5 pounds maximum force)?</p>	<p><input type="checkbox"/> Yes <input type="checkbox"/> No</p> <p>Measurement:</p>		<p>Photo #: 3.6</p>	<ul style="list-style-type: none"> • Adjust or replace closers • Install lighter doors • Install power-assisted or automatic door openers
<p>3.12 If the door has a closer, does it take at least 5 seconds to close from an open position of 90 degrees to a position of 12 degrees from the latch?</p>	<p><input type="checkbox"/> Yes <input type="checkbox"/> No</p> <p>Measurement:</p>		<p>Photo #: 3.6</p>	<ul style="list-style-type: none"> • Adjust closer • •

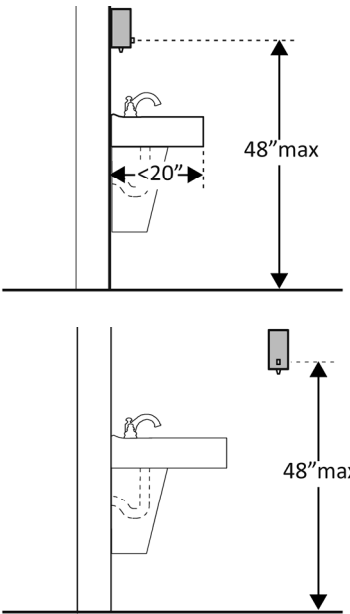
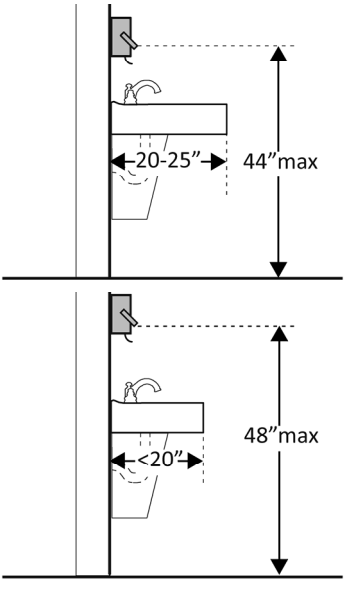
<p>3.13 If there are two doors in a series, e.g. vestibule, is the distance between the doors at least 48 inches plus the width of the doors when swinging into the space?</p>	<p><input type="checkbox"/> Yes <input type="checkbox"/> No</p> <p>Measurement:</p>		<p style="text-align: center; color: red; font-weight: bold;">NA</p> <p>Photo #:</p>	<ul style="list-style-type: none"> • Remove inner door • Change door swing •
<p>3.14 If there is a privacy wall and the door swings out, is there at least 24 inches of maneuvering clearance beyond the door latch side and 42 inches to the privacy wall?</p>	<p><input type="checkbox"/> Yes <input type="checkbox"/> No</p> <p>Measurement:</p>		<p style="text-align: center; color: red; font-weight: bold;">NA</p> <p>Photo #:</p>	<ul style="list-style-type: none"> • Reconfigure space • •

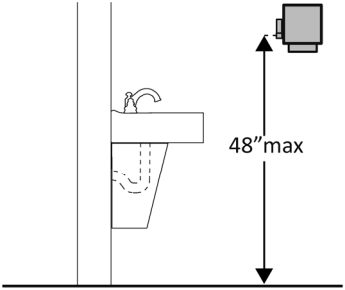
<p>3.15 If there is a privacy wall and the door swings in, is there at least 24 inches of maneuvering clearance beyond the door latch side and at least 48 inches to the privacy wall if there is no door closer or at least 54 inches if there is a door closer?</p>	<p><input type="checkbox"/> Yes <input type="checkbox"/> No</p> <p>Measurement:</p>		<p style="text-align: center; color: red; font-weight: bold;">NA</p> <p>Photo #:</p>	<ul style="list-style-type: none"> • Reconfigure space • •
<p>In the Toilet Room</p>				
<p>3.16 Is there a clear path to at least one of each type of fixture, e.g. lavatory, hand dryer, etc., that is at least 36 inches wide?</p>	<p><input checked="" type="checkbox"/> Yes <input type="checkbox"/> No</p> <p>Measurement:</p> <p style="color: red; font-weight: bold;">47"</p>		<p>Photo #: 3.6</p>	<ul style="list-style-type: none"> • Remove obstructions • •
<p>3.17 Is there clear floor space available for a person in a wheelchair to turn around, i.e. a circle at least 60 inches in diameter or a T-shaped space within a 60-inch square?*</p>	<p><input checked="" type="checkbox"/> Yes <input type="checkbox"/> No</p> <p>Measurement:</p>		<p>Photo #:</p>	<p>*The door to the toilet room may swing into the required turning space</p> <ul style="list-style-type: none"> • Move or remove partitions, fixtures or objects such as trash cans • •

<p>3.18 In a single user toilet room if the door swings in and over a clear floor space at an accessible fixture, is there a clear floor space at least 30 x 48 inches beyond the swing of the door?</p>	<p><input type="checkbox"/> Yes <input type="checkbox"/> No</p> <p>Measurement:</p>		<p style="text-align: center;">NA</p> <p>Photo #:</p>	<ul style="list-style-type: none"> • Reverse door swing • Alter toilet room •
<p>3.19 If the mirror is over a lavatory or countertop, is the bottom edge of the reflecting surface no higher than 40 inches above the floor? Or If the mirror is not over the lavatory or countertop, is the bottom edge of the reflecting surface no higher than 35 inches above the floor?*</p>	<p><input checked="" type="checkbox"/> Yes <input type="checkbox"/> No</p> <p>Measurement:</p> <p style="text-align: center;">39 ½"</p> <p><input type="checkbox"/> Yes <input type="checkbox"/> No</p> <p>Measurement:</p> <p style="text-align: center;">NA</p>		<p>Photo #: 3.19</p>	<p>* If installed before 3/15/2012 and the bottom edge of the reflecting surface is no higher than 40 inches above the floor, lowering the mirror to 35 inches is not required</p> <ul style="list-style-type: none"> • Lower the mirror • Add another mirror •
<p>3.20 If there is a coat hook, is it no less than 15 inches and no greater than 48 inches above the floor?</p>	<p><input type="checkbox"/> Yes <input checked="" type="checkbox"/> No</p> <p>Measurement:</p> <p style="text-align: center;">62"</p>		<p>Photo #: 3.20</p>	<ul style="list-style-type: none"> • Adjust hook • Replace with or provide additional accessible hook •

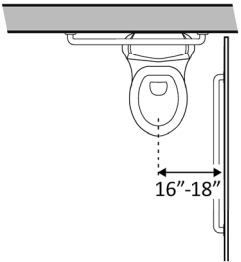
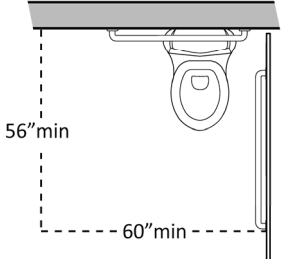
Lavatories (2010 Standards – 606) Note: 2010 Standards refer to sinks in toilet rooms as lavatories.				
<p>3.21 Does at least one lavatory have a clear floor space for a forward approach at least 30 inches wide and 48 inches long?</p>	<p><input checked="" type="checkbox"/> Yes <input type="checkbox"/> No</p> <p>Measurement: 30" X 60"</p>		<p>Photo #: 3.19</p>	<ul style="list-style-type: none"> • Alter lavatory • Replace lavatory •
<p>3.22 Do no less than 17 inches and no greater than 25 inches of the clear floor space extend under the lavatory so that a person using a wheelchair can get close enough to reach the faucet?</p>	<p><input checked="" type="checkbox"/> Yes <input type="checkbox"/> No</p> <p>Measurement:</p>		<p>Photo #: 3.19</p>	<ul style="list-style-type: none"> • Alter lavatory • Replace lavatory •
<p>3.23 Is the front of the lavatory or counter surface, whichever is higher, no more than 34 inches above the floor?</p>	<p><input checked="" type="checkbox"/> Yes <input type="checkbox"/> No</p> <p>Measurement:</p>		<p>Photo #: 3.19</p>	<ul style="list-style-type: none"> • Alter lavatory • Replace lavatory •
<p>3.24 Is there at least 27 inches clearance from the floor to the bottom of the lavatory that extends at least 8 inches under the lav for knee clearance?</p>	<p><input checked="" type="checkbox"/> Yes <input type="checkbox"/> No</p> <p>Measurement:</p>		<p>Photo #: 3.19</p>	<ul style="list-style-type: none"> • Alter lavatory • Replace lavatory •

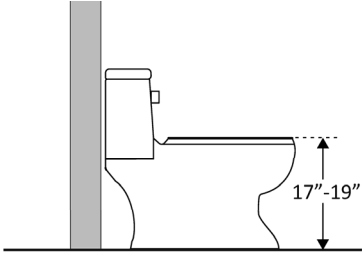
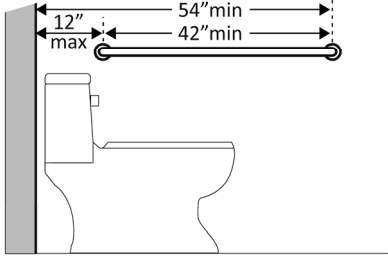
<p>3.25 Is there toe clearance at least 9 inches high? (Space extending greater than 6 inches beyond the available toe clearance at 9 inches above the floor is not considered toe clearance.)</p>	<p><input checked="" type="checkbox"/> Yes <input type="checkbox"/> No</p>		<p>Photo #: 3.25</p>	<ul style="list-style-type: none"> • Alter lavatory • Replace lavatory •
<p>3.26 Are pipes below the lavatory insulated or otherwise configured to protect against contact?</p>	<p><input type="checkbox"/> Yes <input checked="" type="checkbox"/> No</p>		<p>Photo #: 3.25</p>	<ul style="list-style-type: none"> • Install insulation • Install cover panel •
<p>3.27 Can the faucet be operated without tight grasping, pinching, or twisting of the wrist? Is the force required to activate the faucet no greater than 5 pounds?</p>	<p><input type="checkbox"/> Yes <input type="checkbox"/> No <input type="checkbox"/> Yes <input type="checkbox"/> No</p>		<p>NA – SENSOR ACTIVATED</p> <p>Photo #:</p>	<ul style="list-style-type: none"> • Adjust faucet • Replace faucet •
<p>Soap Dispensers and Hand Dryers (2010 Standards – 603)</p>				
<p>3.28 Are the operable parts of the soap dispenser within one of the following reach ranges: Above lavatories or counters no less than 20 inches and no greater than 25 inches deep: no higher than 44 inches above the floor?</p>	<p><input type="checkbox"/> Yes <input type="checkbox"/> No Measurement:</p>			<ul style="list-style-type: none"> • Adjust dispensers • Replace with or provide additional accessible dispensers •

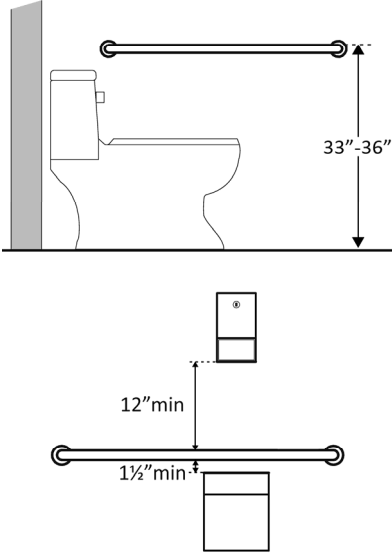
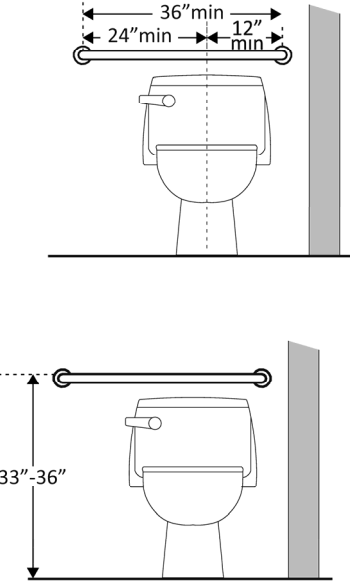
<p>Above lavatories less than 20 inches deep: no higher than 48 inches above the floor?</p> <p>Not over an obstruction: no higher than 48 inches above the floor?</p>	<p><input type="checkbox"/> Yes <input type="checkbox"/> No Measurement:</p> <p><input type="checkbox"/> Yes <input type="checkbox"/> No Measurement: NA</p>		<p>NA</p> <p>Photo #: 3.28</p>	
<p>3.29 Are the operable parts of the hand dryer or towel dispenser within one of the following reach ranges:</p> <p>Above lavatories or counters no less than 20 inches and no greater than 25 inches deep: no higher than 44 inches above the floor?</p> <p>Above lavatories less than 20 inches deep: no higher than 48 inches above the floor?</p> <p>Not over an obstruction: no higher than 48 inches above the floor?</p>	<p><input type="checkbox"/> Yes <input type="checkbox"/> No Measurement: NA</p> <p><input type="checkbox"/> Yes <input type="checkbox"/> No Measurement: NA</p> <p><input checked="" type="checkbox"/> Yes <input type="checkbox"/> No Measurement:</p>			<ul style="list-style-type: none"> • Adjust dispensers • Replace with or provide additional accessible dispensers •

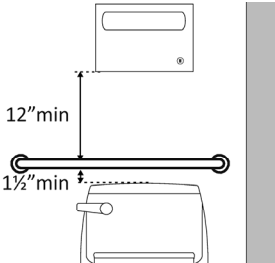
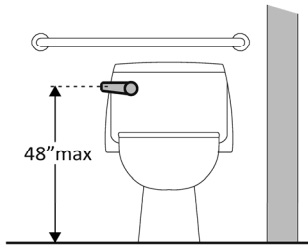
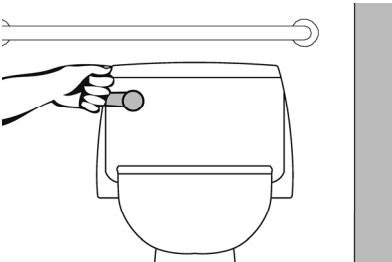
<p>Can the operable parts of the hand dryer or towel dispenser be operated without tight grasping, pinching or twisting of the wrist?</p> <p>Is the force required to activate the hand dryer or towel dispenser no greater than 5 pounds?</p>	<p><input checked="" type="checkbox"/> Yes <input type="checkbox"/> No</p> <p><input checked="" type="checkbox"/> Yes <input type="checkbox"/> No</p> <p>Measurement: 5 LB</p>		<p>Photo #: 3.29</p>	
--	---	--	-----------------------------	--

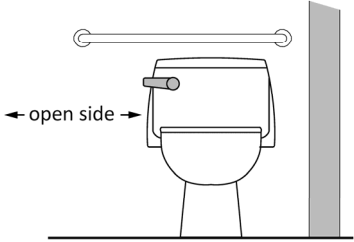
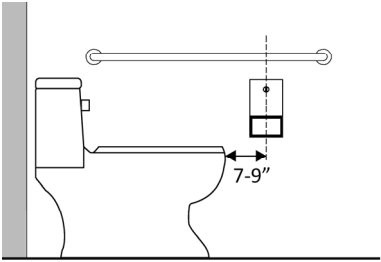
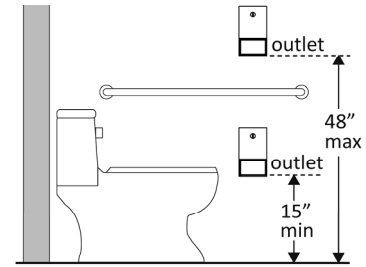
Water Closets in Single-User Toilet Rooms and Compartments (Stalls) (2010 Standards – 603 & 609) Note: 2010 Standards refer to toilets as water closets.

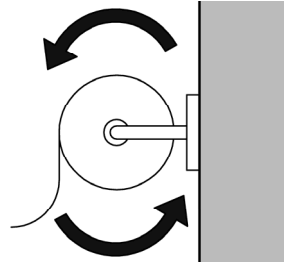
<p>3.30 Is the centerline of the water closet no less than 16 inches and no greater than 18 inches from the side wall or partition?</p>	<p><input type="checkbox"/> Yes <input checked="" type="checkbox"/> No</p> <p>Measurement: 20"</p>		<p>Photo #: 3.30</p>	<ul style="list-style-type: none"> • Move toilet • Replace toilet • Move partition •
<p>3.31 Is clearance provided around the water closet measuring at least 60 inches from the side wall and at least 56 inches from the rear wall?*</p>	<p><input type="checkbox"/> Yes <input checked="" type="checkbox"/> No</p> <p>Measurement: 20"</p>		<p>Photo #: 3.30</p>	<p>* If constructed before 3/15/12, clearances around water closets in single user toilet rooms can be 48 inches wide by 66 inches long or 48 inches wide by 56 inches long (depending on the approach to the water closet, see 1991 Standards Figure 28) and the lavatory may overlap that clearance if the door to the room does</p>

			<p>Photo #: 3.30</p>	<p>not swing into the required clearances at fixtures (such as lavatories, water closet and urinals) and the edge of the lavatory is at least 18 inches from the centerline of the water closet</p> <ul style="list-style-type: none"> Alter room/compartment for clearance
<p>3.32 Is the height of the water closet no less than 17 inches and no greater than 19 inches above the floor measured to the top of the seat?</p>	<p><input checked="" type="checkbox"/> Yes <input type="checkbox"/> No</p> <p>Measurement:</p> <p>19"</p>		<p>Photo #: 3.30</p>	<ul style="list-style-type: none"> Adjust toilet height Replace toilet
<p>3.33 Is there a grab bar at least 42 inches long on the side wall?</p> <p>Is it located no more than 12 inches from the rear wall?</p> <p>Does it extend at least 54 inches from the rear wall?</p> <p>Is it mounted no less than 33 inches and no greater than 36 inches above the floor to the</p>	<p><input type="checkbox"/> Yes <input checked="" type="checkbox"/> No</p> <p>Measurement:</p> <p>24"</p> <p><input checked="" type="checkbox"/> Yes <input type="checkbox"/> No</p> <p>Measurement:</p> <p>6"</p> <p><input checked="" type="checkbox"/> Yes <input type="checkbox"/> No</p> <p>Measurement:</p> <p>24"</p> <p><input checked="" type="checkbox"/> Yes <input type="checkbox"/> No</p> <p>Measurement:</p>		<p>Photo #: 3.30</p>	<ul style="list-style-type: none"> Install grab bar Relocate grab bar Relocate objects

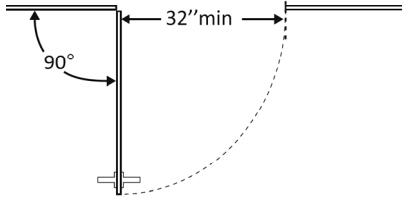
<p>top of the gripping surface?</p> <p>Is there at least 12 inches clearance between the grab bar and protruding objects above?*</p> <p>Is there at least 1½ inches clearance between the grab bar and projecting objects below?*</p> <p>Is the space between the wall and the grab bar 1 ½ inches?</p>	<p style="text-align: center;">33"</p> <p><input type="checkbox"/> Yes <input checked="" type="checkbox"/> No Measurement:</p> <p><input type="checkbox"/> Yes <input checked="" type="checkbox"/> No Measurement:</p> <p><input type="checkbox"/> Yes <input checked="" type="checkbox"/> No Measurement:</p> <p style="text-align: center;">8"</p>		<p>Photo #: 3.30</p>	<p>* If constructed before 3/15/2012 grab bars do not need to be relocated; there are no space requirements above and below grab bars in the 1991 Standards</p>
<p>3.34 Is there a grab bar at least 36 inches long on the rear wall?</p> <p>Does it extend at least 12 inches from the centerline of the water closet on one side (side wall)?</p> <p>Does it extend at least 24 inches on the other (open) side?</p> <p>Is it mounted no less than 33 inches and no greater than 36 inches above the floor to the top of the gripping surface?</p> <p>Are there at least 12 inches</p>	<p><input type="checkbox"/> Yes <input type="checkbox"/> No Measurement:</p> <p><input type="checkbox"/> Yes <input type="checkbox"/> No Measurement:</p> <p><input type="checkbox"/> Yes <input type="checkbox"/> No Measurement:</p> <p><input type="checkbox"/> Yes <input type="checkbox"/> No Measurement:</p> <p><input type="checkbox"/> Yes <input type="checkbox"/> No</p>		<p>Photo #:</p> <p>Photo #: 3.34</p>	<ul style="list-style-type: none"> • Install grab bar • Relocate grab bar • Relocate objects •

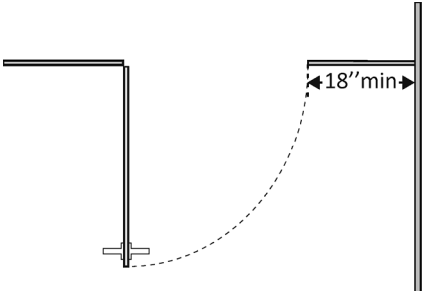
<p>clearance between the grab bar and protruding objects above?*</p> <p>Are there at least 1½ inches clearance between the grab bar and projecting objects below?*</p> <p>Is the space between the wall and the grab bar 1 ½ inches?</p>	<p>Measurement:</p> <p><input type="checkbox"/> Yes <input type="checkbox"/> No</p> <p>Measurement:</p> <p><input type="checkbox"/> Yes <input type="checkbox"/> No</p> <p>Measurement:</p> <p><input type="checkbox"/> Yes <input type="checkbox"/> No</p>		<p>Photo #: 3.34</p>	<p>* If constructed before 3/15/2012 grab bars do not need to be relocated; there are no space requirements above and below grab bars in the 1991 Standards</p>
<p>3.35 If the flush control is hand operated, is the operable part located no higher than 48 inches above the floor?</p>	<p><input type="checkbox"/> Yes <input type="checkbox"/> No</p> <p>Measurement:</p>		<p>Photo #: NA</p>	<ul style="list-style-type: none"> • Move control • Install sensor with override button no higher than 48 inches •
<p>3.36 If the flush control is hand operated, can it be operated with one hand and without tight grasping, pinching, or twisting of the wrist?</p> <p>Is the force required to activate the flush control no greater than 5 pounds?</p>	<p><input type="checkbox"/> Yes <input type="checkbox"/> No</p> <p><input type="checkbox"/> Yes <input type="checkbox"/> No</p> <p>Measurement:</p>		<p>Photo #: NA</p>	<ul style="list-style-type: none"> • Change control • Adjust control •

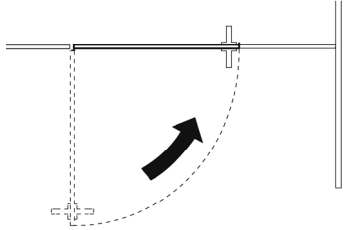
<p>3.37 Is the flush control on the open side of the water closet?</p>	<p><input type="checkbox"/> Yes <input checked="" type="checkbox"/> No</p> <p>20"</p>		<p>Photo #: 3.37</p>	<ul style="list-style-type: none"> • Move control • •
<p>3.38 Is the toilet paper dispenser located no less than 7 inches and no greater than 9 inches from the front of the water closet to the centerline of the dispenser?*</p>	<p><input type="checkbox"/> Yes <input checked="" type="checkbox"/> No</p> <p>Measurement:</p> <p>15"</p>		<p>Photo #: 3.38</p>	<p>* If constructed before 3/15/2012 dispenser does not need to be relocated if it is within reach from the water closet seat; the 1991 Standards do not specify distance from the front of the water closet</p> <ul style="list-style-type: none"> • Relocate dispenser • •
<p>3.39 Is the outlet of the dispenser:</p> <p>Located no less than 15 inches and no greater than 48 inches above the floor?</p> <p>Not located behind grab bars?</p>	<p><input checked="" type="checkbox"/> Yes <input type="checkbox"/> No</p> <p>Measurement:</p> <p><input checked="" type="checkbox"/> Yes <input type="checkbox"/> No</p>		<p>Photo #: 3.38</p>	<ul style="list-style-type: none"> • Relocate dispenser • •

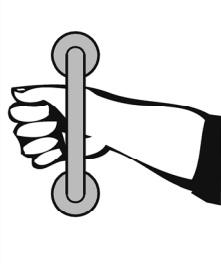
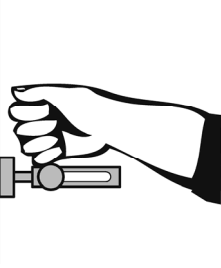
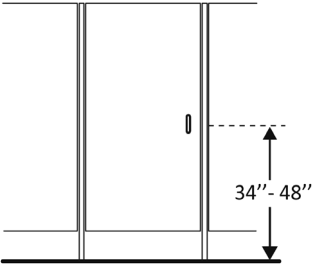
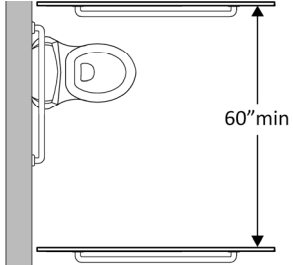
<p>3.40 Does the dispenser allow continuous paper flow?</p>	<p><input checked="" type="checkbox"/> Yes <input type="checkbox"/> No</p>		<p>Photo #: 3.38</p>	<ul style="list-style-type: none"> • Adjust dispenser • Replace dispenser •
--	--	---	-----------------------------	--

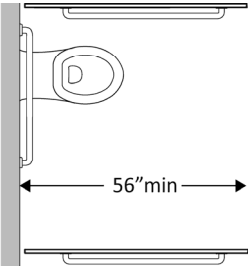
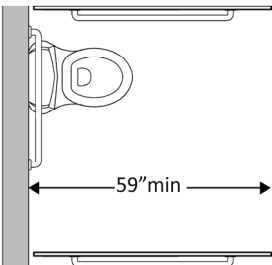
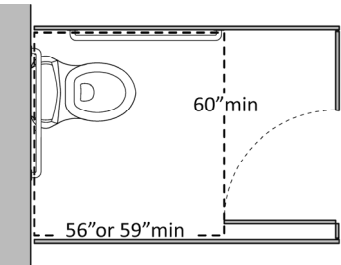
Toilet Compartments (Stalls) (2010 Standards – 604)

<p>3.41 Is the door opening width at least 32 inches clear, between the face of the door and the stop, when the door is open 90 degrees?</p>	<p><input checked="" type="checkbox"/> Yes <input type="checkbox"/> No</p> <p>Measurement: 32"</p>		<p>Photo #: 3.41</p>	<ul style="list-style-type: none"> • Widen door width • •
---	---	--	-----------------------------	--

<p>3.42 If there is a front approach to the pull side of the door, is there at least 18 inches of maneuvering clearance beyond the latch side plus 60 inches clear depth?*</p>	<p><input type="checkbox"/> Yes <input checked="" type="checkbox"/> No</p> <p>Measurement: 6"</p>		<p>Photo #: 3.41</p>	<p>*See 2010 Standards 604.8.1.2 Doors for maneuvering clearance requirements on the push side of the door and side approaches to the pull side of the door</p> <ul style="list-style-type: none"> • Remove obstructions •
---	--	---	-----------------------------	--

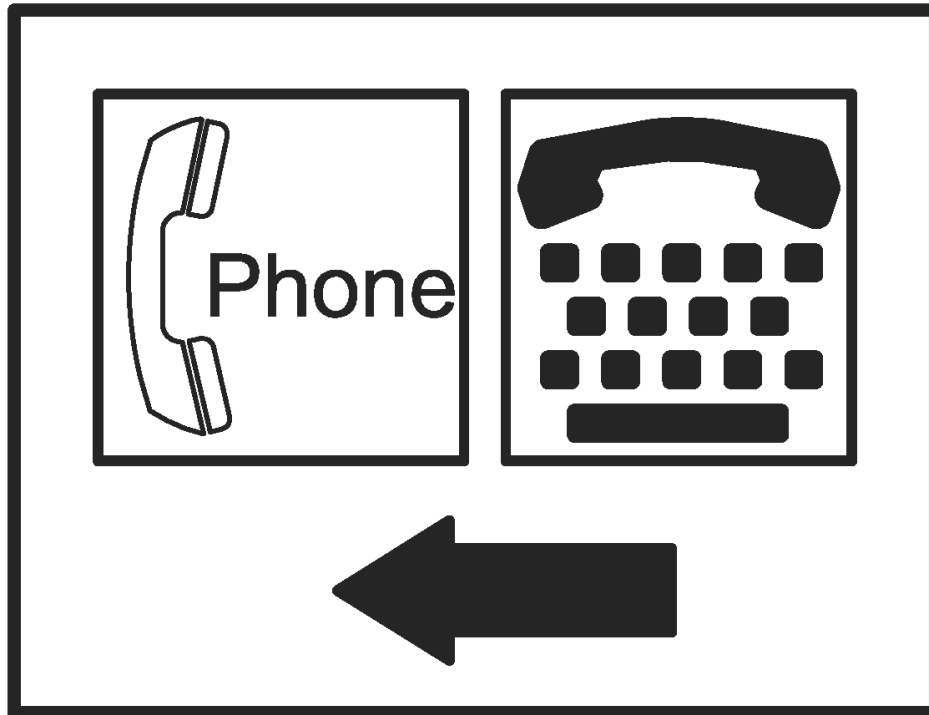
<p>3.43 Is the door self-closing?</p>	<p><input type="checkbox"/> Yes <input checked="" type="checkbox"/> No</p>		<p>Photo #: 3.41</p>	<ul style="list-style-type: none"> • Add closer • Replace door •
--	--	--	-----------------------------	---

<p>3.44 Are there door pulls on both sides of the door that are operable with one hand and do not require tight grasping pinching or twisting of the wrist?*</p>	<p><input type="checkbox"/> Yes <input checked="" type="checkbox"/> No</p>		<p>Photo #: 3.41</p>	<p>* If constructed before 3/15/2012 door pulls do not need to be added; door pulls are not required in the 1991 Standards</p> <ul style="list-style-type: none"> • Replace hardware • •
<p>3.45 Is the lock operable with one hand and without tight grasping, pinching or twisting of the wrist?</p>	<p><input checked="" type="checkbox"/> Yes <input type="checkbox"/> No</p>		<p>Photo #: 3.41</p>	<ul style="list-style-type: none"> • Replace lock • •
<p>3.46 Are the operable parts of the door hardware mounted no less than 34 inches and no greater than 48 inches above the floor?</p>	<p><input checked="" type="checkbox"/> Yes <input type="checkbox"/> No</p> <p>Measurement: 41"</p>		<p>Photo #: 3.41</p>	<ul style="list-style-type: none"> • Relocate hardware • •
<p>3.47 Is the compartment at least 60 inches wide?</p>	<p><input type="checkbox"/> Yes <input checked="" type="checkbox"/> No</p> <p>Measurement: 38"</p>		<p>Photo #: 3.37</p>	<ul style="list-style-type: none"> • Widen compartment • •

<p>3.48 If the water closet is wall hung, is the compartment at least 56 inches deep?</p>	<p><input checked="" type="checkbox"/> Yes <input type="checkbox"/> No</p> <p>Measurement: 66"</p>		<p>Photo #: 3.37</p>	<ul style="list-style-type: none"> • Widen compartment • •
<p>3.49 If the water closet is floor mounted, is the compartment at least 59 inches deep?</p>	<p><input type="checkbox"/> Yes <input type="checkbox"/> No</p> <p>Measurement:</p>		<p>Photo #: NA</p>	<ul style="list-style-type: none"> • Alter compartment • •
<p>3.50 If the door swings in, is the minimum required compartment area provided beyond the swing of the door (60 inches x 56 inches if water closet is wall hung or 59 inches if water closet is floor mounted)?</p>	<p><input type="checkbox"/> Yes <input type="checkbox"/> No</p> <p>Measurement:</p>		<p>Photo #: NA</p>	<ul style="list-style-type: none"> • Reverse door swing • Alter compartment •
	<p><input type="checkbox"/> Yes <input type="checkbox"/> No</p>		<p>Photo #:</p>	<ul style="list-style-type: none"> • • •
	<p><input type="checkbox"/> Yes <input type="checkbox"/> No</p>		<p>Photo #:</p>	<ul style="list-style-type: none"> • • •

ADA Checklist for Readily Achievable Barrier Removal

Priority 4 – Additional Access



Project **SDDOT Rest Area Improvements**

FHU Reference Number 13-039-01

TSP Project Number 03120855

Building **HOMESTEAD**

Location **29 N/S., MRM 26**

Date **09-17-2013 (Inspection)**

Surveyors **Timothy Roach, AIA**

Todd Schultz, PE

Robert King, CPD

Contact Information **TSP – (605) 343-6102**

Amenities such as drinking fountains and public telephones should be accessible to people with disabilities.



Institute for Human Centered Design
www.HumanCenteredDesign.org

November 2011



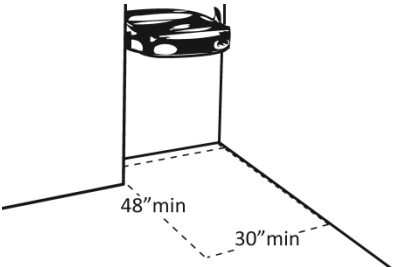
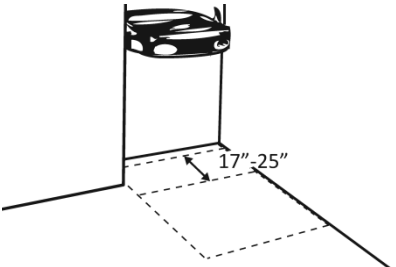
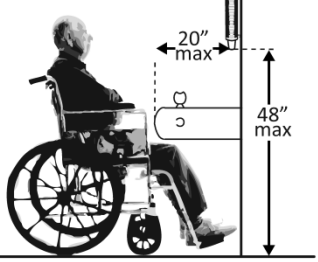
ADA National Network
Questions on the ADA 800-949-4232 voice/tty

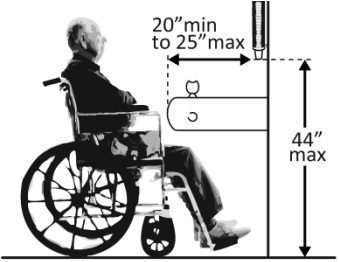

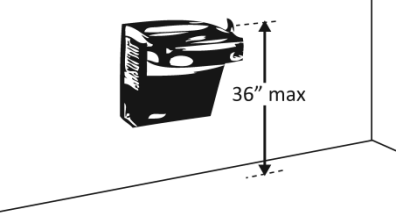
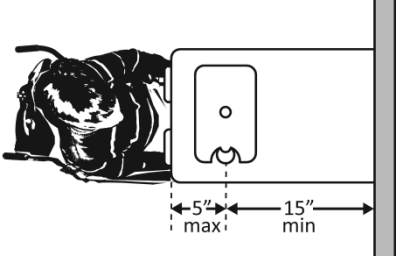
www.ADAchecklist.org

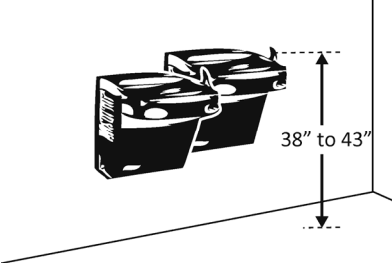
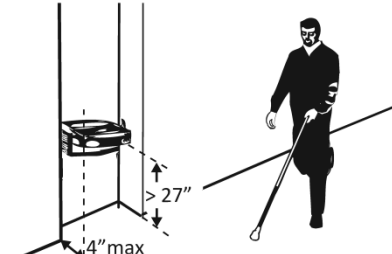
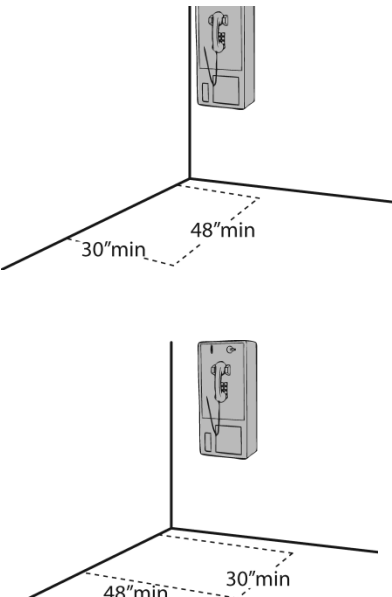
This checklist was produced by the New England ADA Center, a project of the Institute for Human Centered Design and a member of the ADA National Network. This checklist was developed under a grant from the Department of Education, NIDRR grant number H133A060092-09A. However the contents do not necessarily represent the policy of the Department of Education, and you should not assume endorsement by the Federal Government.

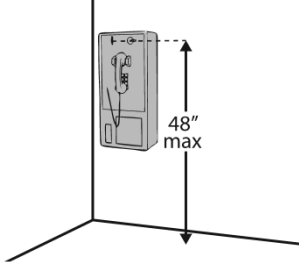
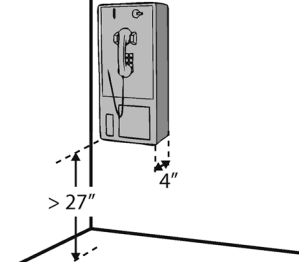


Questions or comments on the checklist contact the New England ADA Center at 617-695-0085 voice/tty or ADAinfo@NewEnglandADA.org




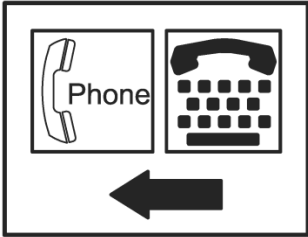
For the full set of checklists, including the checklists for recreation facilities visit www.ADAchecklist.org.

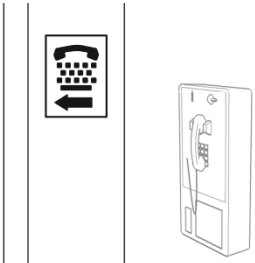

Priority 4 – Additional Access		Comments	Possible Solutions
Drinking Fountains (2010 Standards – 602)			
<p>4.1 Does at least one drinking fountain have a clear floor space at least 30 inches wide x at least 48 inches long centered in front of it for a forward approach?*</p>	<p><input checked="" type="checkbox"/> Yes <input type="checkbox"/> No</p> <p>Measurement: 30 X 48</p>	 <p>48" min 30" min</p>	<p>Photo #: 4.1</p> <p>*If installed before 3/15/2012, a parallel approach is permitted and the clear floor space is not required to be centered</p> <ul style="list-style-type: none"> • Alter space • Relocate drinking fountain • Install a drinking fountain in another location
<p>4.2 If there is a forward approach, do no less than 17 inches and no greater than 25 inches of the clear floor space extend under the drinking fountain?</p>	<p><input checked="" type="checkbox"/> Yes <input type="checkbox"/> No</p> <p>Measurement: 19"</p>	 <p>17"-25"</p>	<p>Photo #: 4.1</p> <ul style="list-style-type: none"> • Alter space • Replace drinking fountain •
<p>4.3 If the drinking fountain is no deeper than 20 inches, are the operable parts no higher than 48 inches above the floor?</p>	<p><input checked="" type="checkbox"/> Yes <input type="checkbox"/> No</p> <p>Measurement: 19"</p>	 <p>20" max 48" max</p>	<p>Photo #: 4.1</p> <ul style="list-style-type: none"> • Adjust drinking fountain • Replace drinking fountain •

<p>4.4 If the drinking fountain is no less than 20 inches and no greater than 25 inches deep, are the operable parts no higher than 44 inches above the floor?</p>	<p><input checked="" type="checkbox"/> Yes <input type="checkbox"/> No Measurement: 29 ½"</p>		<p>NA</p> <p>Photo #: 4.1</p>	<ul style="list-style-type: none"> • Adjust drinking fountain • Replace drinking fountain •
<p>4.5 Can the control be operated with one hand and without tight grasping, pinching or twisting of the wrist?</p> <p>Is the force required to activate the control no more than 5 pounds?</p>	<p><input checked="" type="checkbox"/> Yes <input type="checkbox"/> No Measurement: 1 LB</p>		<p>Photo #: 4.1</p>	<ul style="list-style-type: none"> • Change control • Adjust control •
<p>4.6 Is the spout outlet no higher than 36 inches above the floor?</p>	<p><input checked="" type="checkbox"/> Yes <input type="checkbox"/> No Measurement: 31 ½"</p>		<p>Photo #: 4.1</p>	<ul style="list-style-type: none"> • Adjust drinking fountain • Replace drinking fountain •
<p>4.7 Is the spout:</p> <p>At least 15 inches from the rear of the drinking fountain?</p> <p>No more than 5 inches from the front of the drinking fountain?</p>	<p><input checked="" type="checkbox"/> Yes <input type="checkbox"/> No Measurement: 17"</p> <p><input checked="" type="checkbox"/> Yes <input type="checkbox"/> No Measurement: 2"</p>		<p>Photo #: 4.1</p>	<ul style="list-style-type: none"> • Adjust spout • Replace drinking fountain •

<p>4.8 If there is more than one drinking fountain, is there at least one for standing persons?</p> <p>Is the spout outlet no lower than 38 inches and no higher than 43 inches above the floor?</p>	<p><input type="checkbox"/> Yes <input type="checkbox"/> No</p> <p><input type="checkbox"/> Yes <input type="checkbox"/> No</p> <p>Measurement:</p>		<p style="text-align: center; color: red; font-weight: bold;">NA</p> <p>Photo #:</p>	<ul style="list-style-type: none"> • Adjust drinking fountain • Install new drinking fountain for standing height •
<p>4.9 If the leading (bottom) edge of the fountain is higher than 27 inches above the floor, does the front of the fountain protrude no more than 4 inches into the circulation path?</p>	<p><input type="checkbox"/> Yes <input checked="" type="checkbox"/> No</p> <p>Measurement:</p> <p style="color: red; font-weight: bold;">25 ½"</p>		<p>Photo #: 4.1</p>	<ul style="list-style-type: none"> • Adjust drinking fountain • Replace drinking fountain • Add tactile warning such as permanent planter or partial walls
<p>Public Telephones (2010 Standards – 704) TTY's are devices that employ interactive text-based communication through the transmission of coded signals across the telephone network. They are mainly used by people who are deaf and/or cannot speak.</p>				
<p>4.10 Does at least one telephone have a clear floor space at least 30 inches wide x at least 48 inches long for a parallel or forward approach?</p>	<p><input checked="" type="checkbox"/> Yes <input type="checkbox"/> No</p> <p style="color: red; font-weight: bold;">30" X 48"</p>		<p>Photo #: 4.10</p>	<ul style="list-style-type: none"> • Move telephone • Install new telephone for clear floor space •

<p>4.11 Is the highest operable part of the telephone no higher than 48 inches above the floor?</p>	<p><input checked="" type="checkbox"/> Yes <input type="checkbox"/> No Measurement: 46"</p>		<p>Photo #: 4.10</p>	<ul style="list-style-type: none"> • Adjust telephone • •
<p>4.12 If the leading (bottom) edge of the telephone is higher than 27 inches above the floor, does the front of the telephone protrude no more than 4 inches into the circulation path?</p>	<p><input checked="" type="checkbox"/> Yes <input type="checkbox"/> No Measurement: 27"</p>		<p>Photo #: 4.10</p>	<ul style="list-style-type: none"> • Adjust telephone • •
<p>4.13 Does at least one telephone have a volume control?</p>	<p><input type="checkbox"/> Yes <input type="checkbox"/> No</p>		<p>Photo #: NA</p>	<ul style="list-style-type: none"> • Install volume control • Replace telephone with one that has volume control •
<p>4.14 Is the volume control identified by a pictogram of a telephone handset with radiating sound waves?</p>	<p><input type="checkbox"/> Yes <input type="checkbox"/> No</p>		<p>Photo #: NA</p>	<ul style="list-style-type: none"> • Add pictogram • •

<p>4.15 Does at least one telephone have a TTY?</p>	<p><input type="checkbox"/> Yes <input type="checkbox"/> No</p>		<p style="text-align: center;">NA</p> <p>Photo #:</p>	<ul style="list-style-type: none"> • Install TTY • •
<p>4.16 Is the touch surface of the TTY keypad at least 34 inches above the floor?</p>	<p><input type="checkbox"/> Yes <input type="checkbox"/> No</p> <p>Measurement:</p>		<p style="text-align: center;">NA</p> <p>Photo #:</p>	<ul style="list-style-type: none"> • If a seat is provided, TTY is not required to be 34 inches minimum above the floor • Adjust height of TTY •
<p>4.17 Is the TTY identified by the International Symbol of TTY?</p>	<p><input type="checkbox"/> Yes <input type="checkbox"/> No</p>		<p style="text-align: center;">NA</p> <p>Photo #:</p>	<ul style="list-style-type: none"> • Add symbol • •
<p>4.18 Do signs that provide direction to public telephones also provide direction to the TTY?</p>	<p><input type="checkbox"/> Yes <input type="checkbox"/> No</p>		<p style="text-align: center;">NA</p> <p>Photo #:</p>	<ul style="list-style-type: none"> • Add signs • •

<p>4.19 Do telephones that do not have a TTY provide direction to the TTY?</p>	<p><input type="checkbox"/> Yes <input type="checkbox"/> No</p>		<p style="text-align: center;">NA</p> <p>Photo #:</p>	<ul style="list-style-type: none"> • Add signs • •
<p>Fire Alarm Systems (2010 Standards – 702)</p>				
<p>4.20 If there are fire alarm systems, do they have both flashing lights and audible signals?</p>	<p><input type="checkbox"/> Yes <input type="checkbox"/> No</p>		<p style="text-align: center;">NA</p> <p>Photo #:</p>	<ul style="list-style-type: none"> • Install audible and visual alarms • •
	<p><input type="checkbox"/> Yes <input type="checkbox"/> No</p>		<p>Photo #:</p>	<ul style="list-style-type: none"> • • •
	<p><input type="checkbox"/> Yes <input type="checkbox"/> No</p>		<p>Photo #:</p>	<ul style="list-style-type: none"> • • •
	<p><input type="checkbox"/> Yes <input type="checkbox"/> No</p>		<p>Photo #:</p>	<ul style="list-style-type: none"> • • •

HOMESTEAD PRIORITY 1



Photo #1.1 10-04-2013 053



Photo #1.2 10-04-2013 056



Photo #1.3 10-04-2013 055



Photo #1.4 10-04-2013 054

HOMESTEAD PRIORITY 1



Photo #1.5 10-04-2013 057



Photo #1.10 10-04-2013 058



Photo # 1.13 10-04-2013 059



Photo # 1.37 10-04-2013 063

HOMESTEAD PRIORITY 1



Photo #1.41 10-04-2013 061



Photo # 1.42 10-04-2013 063



Photo #1.45 10-04-2013 062



Photo #1.46 10-04-2013 064

HOMESTEAD PRIORITY 2



Photo #2.2 10-04-2013 062



Photo #2.8 10-04-2013 068



Photo #2.38 10-04-2013 069



Photo #2.47 10-04-2013 072

HOMESTEAD PRIORITY 2



Photo #2.48 10-04-2013 066



Photo #2.76 IMG_7444

HOMESTEAD PRIORITY 3 – MEN'S



Photo #3.2 10-04-2013 067



Photo #3.4 10-04-2013 066



Photo #3.11 10-04-2013 088



Photo #3.17 10-04-2013 077

HOMESTEAD PRIORITY 3 – MEN'S



Photo #3.19 10-04-2013 079



Photo #3.20 10-04-2013 087



Photo #3.22 10-04-2013 081



Photo #3.29 10-04-2013 089

HOMESTEAD PRIORITY 3 – MEN'S



Photo # 3.30 10-04-2013 083



Photo # 3.34 10-04-2013 085



Photo #3.38 10-04-2013 084



Photo #3.39 10-04-2013 086

HOMESTEAD PRIORITY 3 – MEN'S



Photo #3.43 10-04-2013 080

HOMESTEAD PRIORITY 3 – WOMEN'S



Photo #3.4 10-04-2013 065



Photo #3.5 10-04-2013 070



Photo #3.6 10-04-2013 088



Photo #3.7 10-04-2013 067

HOMESTEAD PRIORITY 3 – WOMEN'S



Photo #3.10 10-04-2013 075



Photo #3.19 10-04-2013 096



Photo #3.20 10-04-2013 101



Photo #3.25 10-04-2013 097

HOMESTEAD PRIORITY 3 – WOMEN'S



Photo # 3.29 10-04-2013 094



Photo # 3.29 10-04-2013 090



Photo #3.30 10-04-2013 102



Photo #3.34 10-04-2013 099

HOMESTEAD PRIORITY 3 – WOMEN'S



Photo #3.37 10-04-2013 098



Photo #3.38 10-04-2013 100



Photo # 3.41 10-04-2013 101

HOMESTEAD PRIORITY 4



Photo #4.1 10-04-2013 068



Photo # 4.10 10-04-2013 103



The Interstate Rest Areas Study: Along the I-29 and I-90 Corridors

APPENDIX C AUDITMATE SUMMARY

Detailed Component List for One Facility
HOME_RA Homestead Rest Area

09/25/13

Class	Component	Comment	Quantity	Unit Cost	Lifespan	Age	Installed	Renewal Cost (RC)	Deferred Cost (DC)
	Storage Building/Garage (approx. 20' x 32')	Needs roof repairs and exterior paint.	1						
	Lodge Pole /Teepee Structure	Fair condition, routine structural review recommended	1						
	Picnic Shelters -(Field Sone, flat mtl deck & trim)	Repair & refinish Steel Roof deck & mtl trim, provide general cleaning, and misc. minor repairs	9						
	Reinforced Concrete Picnic Tables/Benches	Good condition	18						
	Information Display (outdoor)	Good condition - needs heavy cleaning	1						
Exterior Closure									
	Exterior Stone Wall Mortar, Concrete Mortar	Good Condition - Recommend tuckpointing and cleaning w/ general inspection.							
	Masonry Wall Mortar, Concrete Mortar								
	Paint or Stain, Exterior	Fair Condition							
	Garage Door, Metal, single Wide								
	Steel Double Door								
	Steel Single Door, Utility								
	Storefront Double Door, Metal and Glass	worn							
	Metal Sliding Window, Double Pane, Medium Opening	worn							
	Alum. Frame and Glazing	Worn							
	Exterior Eaves and Soffits	Good, need cleaning and paint.							
Roofing and Drainage									
	Asphalt Shingle Roof (?)								
	Box Steel Panel Roof (?)								
	Copper Roof, Standing Seam	weathered, could use cleaning and inspection.							
	Single Ply Roof, Fully Adhered								
	Downspouts, Galvanized Steel, Factory Finish								
	Gutters, Galvanized Steel, Hung, Factory Finish								
	Suspended Ceiling System								
Interior Construction									
	Toilet Partitions, Stainless Steel								
	Ceramic Tile Walls	Need heavy cleaning							
	Painting Interior, Average Grade	good condition							
	Quarry Tile Floors 6x6	Needs heavy cleaning, minor repairs.							
	Toilet Stall door, Stainless Steel								
	Interior Doors & Hardware								
	Information Gate Assembly	Looks worn and old.							
	Information Desk/Counters	Looks worn and old.							
	Interior Paint/ceiling	Looks faded							

Detailed Component List for One Facility
HOME_RA Homestead Rest Area

09/25/13

Class	Component	Comment	Quantity	Unit Cost	Lifespan	Age	Installed	Renewal Cost (RC)	Deferred Cost (DC)
	Interior stone walls	general inspection and cleaning.							
Plumbing									
	Sump Pump	There are no reported issues.							
	Tank, Holding Tank, 8000 gallons	There are no reported issues. Suggest periodically testing for bacterial growth in the tanks.							
	Well Domestic Water Pressure Tanks, Medium	Tanks appear to be in good condition. However there appears to be a water leak at a piping connection. The leak should be repaired as soon as possible							
	Electric Water Cooler, Stainless Steel	Electric Water Cooler is operational. Only preventive maintenance is required.							
	Water Heater, Commercial, Electric, 50 gallons	Water Heater is operational. Only preventive maintenance is required.							
	Faucets (Lav)	Maintenance personnel indicated that faucets require unscheduled maintenance more than three times per year. They indicate that the batteries need frequent replacement.							
	Lavatory Sink, porcelain, Set in Countertop	Good condition. Only preventative maintenance is required. Caulk at countertop should be replaced.							
	Lavatory Sink, porcelain, Wall Hung	Good condition. Only preventative maintenance is required. Caulk at wall should be replaced.							
	Slop Sink, Single Bowl, Enamel	Fixture and faucet are deteriorated due to wear and age.							
	Urinals, Porcelain, Wall-Hung	Appears to be in good condition. Replacing units with low water consumption units will extend the life of the lagoon.							
	Water Closets Porcelain, Wall-Hung	Appears to be in good condition. Replacing units with low water consumption units will extend the life of the lagoon.							
	Domestic Water Pressure Pump	Fully operational. Only periodic maintenance is required.	1 each		15	1	2012		
	Lawn Irrigation Pressure Tank	Tank appears to be in good condition. No leaks.	1 each		30	21	1992		
	Lawn Irrigation Pressure Pump	Pump is operational. However, it is past it's expected service life. A replacement pump is on site, but has not been installed.	1 each		15	21	1992		

Detailed Component List for One Facility
HOME_RA Homestead Rest Area

09/25/13

Class	Component	Comment	Quantity	Unit Cost	Lifespan	Age	Installed	Renewal Cost (RC)	Deferred Cost (DC)
	Flush Valve - Urinal	Maintenance personnel indicated that flush valves require unscheduled maintenance more than three times per year. They indicate that the batteries need frequent replacement.	4 each		20	10	2003		
	Flush Valve - Water Closet	Maintenance personnel indicated that flush valves require unscheduled maintenance more than three times per year. They indicate that the batteries need frequent replacement.	9 each		20	10	2003		
	Hose Bibb - inside the toilet rooms	Appears to be in deteriorated condition. Hose bibb should be replaced.	2 each		20	34	1979		
	Wall Hydrant - outside the building	Appears to be in operational condition. Periodic maintenance is required	3 each		20	34	1979		
	Waste and Vent Piping - Concealed or under floor	Operational, no apparent leaks. Metallic pipe and fittings, cast iron.			50	34	1979		
	Waste and Vent Piping - Exposed locations	Operational, no apparent leaks. Plastic pipe and fittings, PVC.			50	10	2003		
	Water Piping	Operational, no apparent leaks. Plastic pipe and fittings, PVC.			50	34	1979		
	Piping Insulation - Fabric jacketed insulation	Part of domestic water piping is insulated with fabric jacketed pipe insulation. Pipe insulation is adequate, except where small sections are missing. Domestic water piping that is missing insulation should have insulation installed.			30	34	1979		
	Piping Insulation - Closed cell foam insulation	Part of domestic water piping is insulated with closed cell foam insulation. Pipe insulation is adequate.			30	10	2003		
	Valves	Valves are starting to exhibit some corrosion			20	34	1979		
	Pipe Hangers and Supports	Appear to be in good condition. Should last another 25 years if humidity is controlled by proper ventilation.			50	34	1979		
Mechanical									
	Split System Heat Pump Outdoor Condensing Unit, 02-Ton	Unit is operational. No performance or maintenance issues noted. Only routine maintenance is needed.							
	Split System Heat Pump Outdoor Condensing Unit, 05-6 Ton	Unit is operational. No performance or maintenance issues noted. Only routine maintenance is needed.							

Detailed Component List for One Facility
HOME_RA Homestead Rest Area

09/25/13

Class	Component	Comment	Quantity	Unit Cost	Lifespan	Age	Installed	Renewal Cost (RC)	Deferred Cost (DC)
	Air Handling Unit, Split System, Heat Pump, 02.5-3	Unit is operational. No performance or maintenance issues noted. Only routine maintenance is needed.							
	Air Handling Unit, Split System, Heat Pump, 05-6 Ton	Unit is operational. No performance or maintenance issues noted. Only routine maintenance is needed.							
	Utility Set-In-Line Exhaust Fan - Toilet Rooms	Operational. Odor is sometimes noticeable in the toilet rooms, even when the exhaust fan is operating.	2 each		25	34	1979		
	Utility Set-Exhaust Fan - Basement	Fan is not operational. Fan is partially disassembled and abandoned.	1 each		25	34	1979		
	Unit Heater, Electric, Ceiling or Wall Mounted	Units are in operable condition. However, they are beyond their expected service life.			25	34	1979		
	Hydronic Circulation Pump, Base-Mounted, 003 HP								
	Air Distribution Ducts	Ducts, where visible, seem to be in good condition. No air leakage noted.			50	34	1979		
	Air Duct Insulation	Outside air ducts are insulated with external insulation. Insulation shows some deterioration due to age.			50	34	1979		
	Supply and return air outlets/inlets	Units are in operable condition. However, they are showing signs of deterioration.	20		50	34	1979		
	Temperature Controls	Programmable thermostats for the heat pumps are operational.	1		20	13	2000		
Electrical									
	Panelboard, Main Breaker, 3 PH, 208V, 0200-0250A	Fully operational, only preventive maintenance required.							
	Panelboard, MLO, 3 PH, 208V, 0200-0250A	Fully operational, only preventive maintenance required.							
	Incandescent Fixture, Recessed	Fully operational, consider upgrading lamps to more efficient type.							
	Incandescent Fixture, Surface Mounted, Stock	Fully operational, consider upgrading lamps to more efficient type.							
	Incandescent Fixture, Surface Mounted, Stock	Fully operational, consider upgrading lamps to more efficient type.							
	Incandescent Fixture, Track Light, Economy	Fully operational, consider upgrading lamps to more efficient type.							
	Outdoor fixture, Cobrahead	Fully operational, only preventive maintenance required.							
	Outdoor fixture, Post Top Luminaire	Internal wiring in the fixture is deteriorated.							
	Outdoor Fixture, Recessed, Incandescent, Stock								

Detailed Component List for One Facility
HOME_RA Homestead Rest Area

09/25/13

Class	Component	Comment	Quantity	Unit Cost	Lifespan	Age	Installed	Renewal Cost (RC)	Deferred Cost (DC)
	CCTV Camera w/Cabling	Fully operational, only preventive maintenance required.							
	Electric Hand Dryer	Fully operational, only preventive maintenance required.							
	Emergency Beacon - Well Monitoring System	Understand in good condition							
	Phone Unit	Floor Mount, replace - Non ADA compliant	1 each		20	13	2000		
Utilities									
Sanitary Sewer System									
	Lagoons	Lagoons were re-lined approximately 15 years ago. Could use re-lining soon				15			
	Sewage Piping System	No reported problems with piping or manholes until the last manhole. People flushing items down the toilets occasionally clog the last manhole or the pump. Replacing the pump with a grinder pump may alleviate some of the problems.							
Water System (Rural water)									
	Water Pipe System	No reported problems with the water pipes or underground tank. Tank is steel and will need replacing in the future.							
Infrastructure									
	Parking Area, Non Reinforced Concrete 9.5"								
	Sidewalk, Concrete	Most of the concrete walk is in good shape. Exceptions are in the area in front of the building and at the Teepee sculpture. Approximately 20% of the walk should be removed in the next 5 years.							
	Landscaping	Landscaping appears to be in good shape and includes trees, bushes, and grass. Irrigation is working well with yearly maintenance. Refreshing of landscaping should be considered at some time.							
	Wayfinding Signage	Existing signs appear to be in good shape, but could use modernization.							

Detailed Component List for One Facility
HOME_RA Homestead Rest Area

09/25/13

Class	Component	Comment	Quantity	Unit Cost	Lifespan	Age	Installed	Renewal Cost (RC)	Deferred Cost (DC)
	Pavement Concrete	Overall the pavement is in good shape. There is some cracking, especially in the southeast corner and at the entrance drive. Joint repair and sealing needs to be done. Curb removal at the entrance was requested due to semi's rolling over the curb. Slab removal and replacement, especially in the southeast area near the sewage ponds, will need to be done in the next 5 years. Additional pavement was suggested for the east side of the parking lot to allow trucks more room to pull into their parking spaces.							
	Site Lighting - Parking	No lighting issues were identified							
	Site Lighting - Pedestrian	No lighting issues were identified							

**HIDEWOOD NORTHBOUND
REST AREA**

TECHNICAL REVIEW REPORT

Prepared for:

Mr. Brad Remmich
South Dakota Department of Transportation
Office of Project Development
700 East Broadway Avenue
Pierre, SD 57501-2586
(605) 773-3093

Prepared by:

TSP
600 Kansas City Street
Rapid City, SD 57701-2712
(605) 343-6102

Felsburg Holt & Ullevig
6300 South Syracuse Way, Suite 600
Centennial, CO 80111
(303) 721-1440

FHU Reference No. 113039-01
December 2013



The Interstate Rest Areas Study: Along the I-29 and I-90 Corridors

TABLE OF CONTENTS

	<u>Page</u>
I. INTRODUCTION -----	1
II. GENERAL OVERVIEW -----	2
A. Rest Area Layout -----	2
B. Field Visit Observations -----	4
C. User Environment -----	4
D. Existing Building Code Conformity -----	4
E. Americans with Disabilities Act (ADA) Survey -----	5
F. Energy and Water Usage Review -----	6
III. BUILDING SYSTEM OVERVIEW -----	7
A. Architectural System -----	7
B. Plumbing System -----	7
C. Mechanical System -----	7
D. Electrical System -----	8
E. Sanitary Sewer System -----	8
F. Water System -----	8
G. Infrastructure -----	9
IV. SUMMARY -----	10

APPENDIX A MAINTENANCE STAFF MEETING MINUTES

APPENDIX B ADA SURVEY RESULTS

APPENDIX C AUDITMATE SUMMARY

LIST OF FIGURES

	<u>Page</u>
Figure 1. Hidewood Northbound Rest Area Site Layout -----	3



I. INTRODUCTION

The Hidewood North Rest Area is located along Interstate 29, near the town of Watertown South Dakota. The facility is located approximately 18 miles southeast of Watertown and 28 miles north of Brookings, South Dakota. The rest area has direct access to and from Interstate 29 servicing north bound traffic. It also includes a small overlook site and marker. The truck parking lot is separated from the public parking lot.

The purpose of this report is to summarize the condition of existing site components and building systems for the facility as a whole. The intent for this report is to define the general status of the existing facilities given their age and use.

The report has been divided into two general areas of focus. The first section includes a general overview of the facility design and operations. Architectural issues, including the general capacity of the facilities and current operations, are reviewed and compared to current facility standards (i.e., building codes, ADA, etc.).

The systems overview section covers the type and condition of the components that make up the facility, and includes a summary evaluation of the site and building infrastructure. The site infrastructure repairs/replacement review includes sidewalks, lighting, signage, landscaping, and picnic shelters. The building systems infrastructure review includes items such as the building shell and structure, mechanical and plumbing systems, electrical, interior finishes, and communications/IT equipment.



II. GENERAL OVERVIEW

A. Rest Area Layout

The developed portion of the site is spacious running north to south paralleling the parking lots and interstate to the west. Entry to the rest area is provided via direct access from I-29. Upon entering, parking lots for passenger vehicles and trucks separated. The main facility is centrally located on the higher end of the properties. It includes a small lobby (with no tourist information center), restrooms and mechanical/utility space to the north and south west of the building are the walking paths and picnic shelters. Roughly 500' to the southeast are two sewage ponds supporting the facility.

Outdoor facilities include:

- Four dual brick picnic shelters (2/ea. reinforced concrete tables/bench sets on concrete slabs) approx. 19'x29', one structure has been expanded to also include vending equipment
- One exterior visitor display structure
- Dumping station
- Flag pole

Utilities Include:

- Rural water with underground tank system and pump
- Gravity sewer system with lagoons (2)
- Underground propane tanks (2)
- Electric power and transformer
- Telephone service

The 1,616 square foot facility includes the following:

- Lobby and secured visitor center
- Men's and women's restrooms
- Mechanical, maintenance and storage area

Building Systems include:

- Heating and cooling including split system gas heating and electric cooling units
- Service area heating utilizing a gas fired unit heater
- Ventilation is exhaust with make-up air
- Power is single phase, 120/240 volt, 225 amp
- Gas fired storage type water heater
- Water softener

Figure 1 shows the layout of the Hidewood Northbound Rest Area facility including the rest area's location in relation to major roadways in the area.

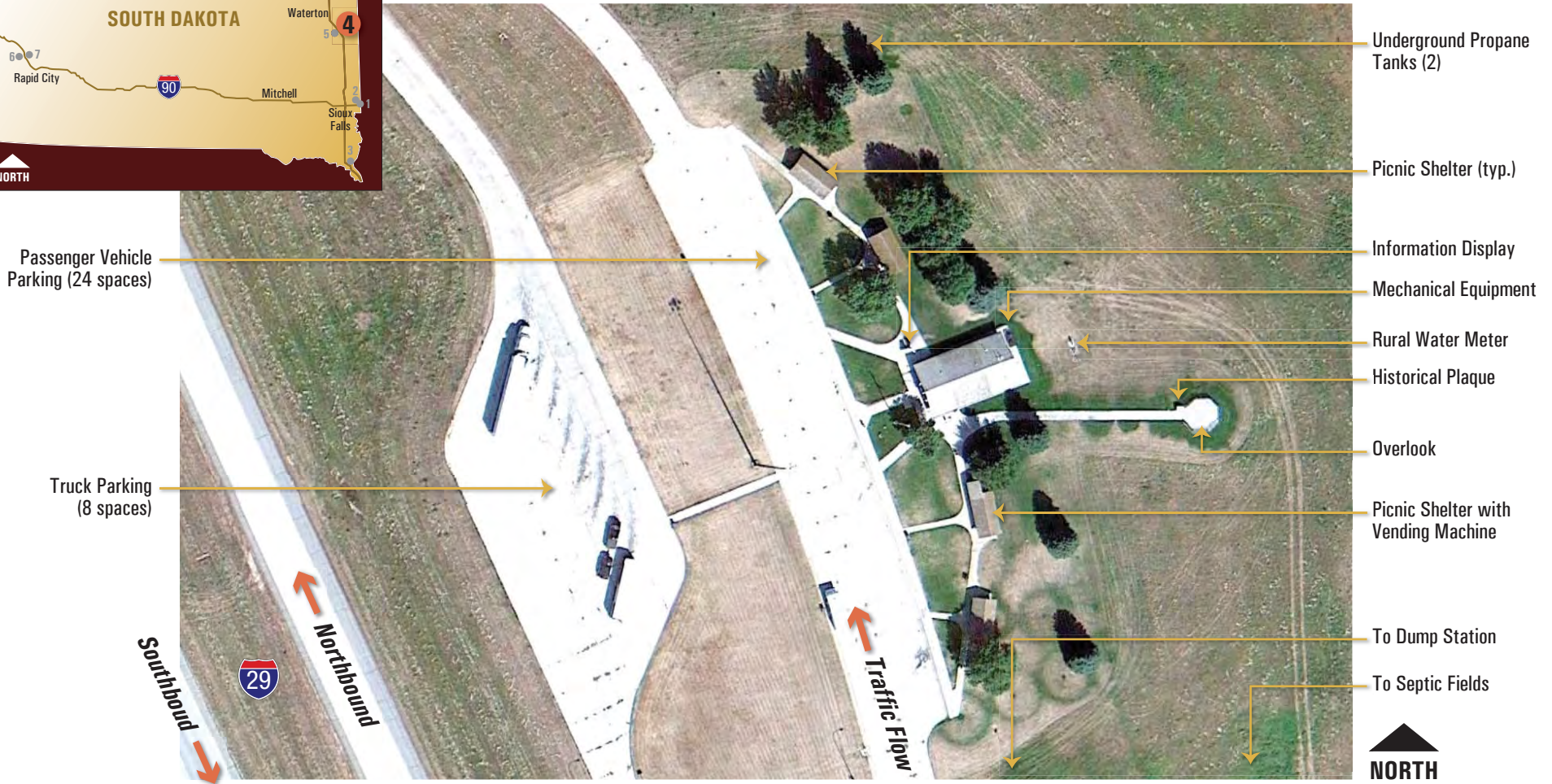


Figure 1. Hidewood Northbound Rest Area Site Layout



B. Field Visit Observations

A field meeting was held with TSP and SDDOT officials on September 17, 2013 to gain initial insights from the SDDOT maintenance team about the operation, history, and condition of the existing on-site facilities at the rest area. A copy of the meeting minutes are contained in the **Appendix A** of this report and the following summarizes the key points of the meeting:

- The original portion of the facility was designed and constructed in 1980 with an addition to both the front (for lobby space) and rear (mechanical/utility room) in 1992.
- The site has been well maintained, there are some age related issues requiring repairs (sidewalks, picnic shelter roofs, etc.) and replacement (lighting, and the sprinkler system).
- The facility shell is in good condition given the age, with the exception of the cedar shingle roof system which is failing. The interiors are in good condition, and may require updating, heavy cleaning, refinishing and interior lighting. The existing furnace and supporting equipment are nearing their design life.
- There have been limited improvements made to the facility to address some ADA requirements, and building codes. In general, the restrooms are small and narrow, with minimal space for circulation. Also, access to the restrooms from the lobby will likely require rework of interior bearing walls to reconfigure entrances. There may be a need to expand the restrooms to accommodate 5' wide toilet facilities, and possibly family rooms.
- The truck parking lot should be studied to determine the need for expansion.

C. User Environment

The facility and site are visible from mainline Interstate 29. Architecturally, the site is inviting as it not too cluttered, and there are very nice views of the open and historic grass lands to the east. The truck parking area is separated from the general public areas. The brick and cedar roofed building and picnic shelters are utilitarian (mostly functional and non-descript), are reaching their design life and in good condition. The interior brick lobbies are open and comfortable. The restrooms are noticeably small and in good shape, and may require additional lighting, heavy cleaning, and improved ventilation.

The environment overall is clean, well maintained and reasonably comfortable. The facility and structures are unprotected from the winds, being surrounded by the prairie. In general, the site is functional/uninspired and could be from anywhere in the country. There is a historic site marker which adds interest to the property.

D. Existing Building Code Conformity

The current facilities were designed and constructed in 1980 and upgraded in 1992, to the codes at the time which lacked consideration for people with disabilities. To quantify the differences in code standards, the existing main building was evaluated per the ICC 2012 International Building Code which has been adopted by the State of South Dakota. Based on



the use of the existing facility, the following building classifications were utilized in the comparison:

- Size: 1,616 square feet
- Occupant Type: Mercantile
- Construction Type: Type 3-b (or 5-b)
- Occupant Load: < 50
- Maximum access travel: 75 feet
- Required Exits: 1

The following outline the major areas where the existing building deviates from the requirements of the current Building Code (IBC 2012):

- Facility does not include a family / assisted-use restroom
- Several areas are not ADA compliant per ICC A117.1-2009 (outlined in proceeding sections of this report)

It should be noted that per the “Existing” Building Code, unless there are significant safety hazards, the facilities are not required to be modernized as a whole to meet current code standards. However, any repairs or new additions will need to be completed to these standards. The exception concerns ADA requirements, which are a retroactive federal requirement. When the ADA is addressed the project will need to also be completed per building code, which includes accessibility criteria (ICC- A117.1-2009).

E. Americans with Disabilities Act (ADA) Survey

As stated previously, the building was originally constructed prior to the full implementation of ADA standards. Restrooms have stalls for ambulatory use (3'-4" wide), and gang sinks with electronic sensors. To quantify the improvements required for compliance with current ADA standards, a detailed survey was completed utilizing the “ADA Checklist for Readily Achievable Barrier Removal” per the DOJ ADA Standards for Accessible Design - 2010. The survey identified the following general deficiencies, and more detailed information is referenced in **Appendix B** of this report:

Priority 1 Deficiencies (access to building):

- Accessible parking spaces at the front of the building meet maximum slope limitations and the accessible entrance walk meets ADA requirements
- Parking signs meet current MUTCD and ADA standards with the exception of a Van Accessible sign which is needed for one of the spaces
- ADA pull handle on entrance door has insufficient clearance
- Door closer takes less than 5 seconds to close from and open position

Priority 2 Deficiencies (Access to Goods and Services):

- CCTV Information Area:
 - Signage, upgrade signs to current ADA standards



The Interstate Rest Areas Study: Along the I-29 and I-90 Corridors

Priority 3 (Restrooms):

- Stall doors not self-closing
- The sign on the wall, located on the push side of the door does not meet ADA standards
- There is not adequate clearance on the pull side of the door
- The door hardware is not located in compliance with ADA standards
- The entrance doors cannot be opened with 5 lbs. or less of force
- The door does not take more than 5 seconds to close from an open position
- Soap dispensers above the lavatory counter are more than 44 inches above the floor
- Men's and women's toilet does not have adequate clearance to meet ADA standards
- Grab bars do not meet ADA standards
- Toilet paper holders in men's and women's stalls do not meet ADA standards
- Entrance doors to stalls do not meet closure pressure or ADA pull handle standards
- Toilet compartment is less than 60 inches in width

Priority 4 (additional access) Deficiencies:

- Phone is wall mounted and does not meet ADA standards for sound control, TTY plug in, and shelf.

F. Energy and Water Usage Review

TSP has not received any data concerning this information:



III. BUILDING SYSTEM OVERVIEW

The following sections include a general review of individual building and site components, starting with site components and then broken down by individual disciplines (Architectural Systems, Mechanical, Electrical, Plumbing, and Civil/Site systems). The discussion generally parallels SDDOT AuditMate database format.

A detailed summary of each discipline section in the current AuditMate format including general comments of individual line items are contained in **Appendix C** of this report. The AuditMate contains both existing line items and recommended updates to the SDDOT database, which are shown in **bold** font.

A. Architectural System

The original structure was constructed in 1980, and was expanded in 1992 to add the front and rear sections of the building. The building wall system is a reinforced and insulated masonry bearing wall system that also includes interior masonry bearing walls. It has a wood framed roof with cedar shingles on insulation board, on an exposed laminated and painted wood deck. The exterior of the facility is in good shape and could benefit from tuck-pointing and cleaning (as can the picnic shelters). The cedar roof on the facility and the shelters is in poor condition which can damage the framing, walls, and interiors if not addressed. The interior walls, tile work, and ceilings have been well maintained.

B. Plumbing System

Wall hung water closets and wall hung urinals are vitreous china, installed in 1992. Simulated stone, solid surface countertop with integral lavatory sinks were also installed at that time. Water closet and urinal flush valves are push-button manual type, and lavatory faucets are battery operated. A wall hung electric water cooler and drinking fountain outside the building were installed in 1992.

Underground waste and vent piping is cast iron and installed in 1980. Above floor waste and vent piping is a combination of copper and PVC plastic. Above floor copper piping was installed in 1980, while above floor PVC plastic piping was installed later in 1992. Copper water piping and fiberglass insulation with an all service vapor resistant covering was added in 1992.

Water for domestic use is supplied by a rural water system. The system has a water pressure regulator, water meter, backflow preventer, pressure booster system and a 6000 gallon underground fiberglass holding tank. The system supplies all plumbing fixtures in the building and the lawn irrigation system. There is a water softener for domestic hot and cold water in the building and a gas fired water heater. The water supply system and water softener were installed in 1992, and the gas fired water heater was installed in 2006.

C. Mechanical System

The building is heated and cooled by (2) split systems with indoor gas fired furnaces and outdoor electric cooling condensing units. The outdoor condensing units were installed in 2008 and the indoor gas fired furnaces in 1992. A gas fired unit heater, installed in 1992, in the equipment room provides heating to that room. There are outside air duct connections to both



systems for ventilation. One of the outside air ducts has an electric heater, installed in 1992, to raise the temperature of the outside air before it blends with return air to the gas fired furnace.

Exhaust ventilation for both toilet rooms is ducted to an in-line fan and out of the building. Exhaust grilles are wall mounted on the water closet wall in each toilet room, and was installed in 1992.

D. Electrical System

The building is served by a 120/240 volt, single phase, 225 amp service. There is a main circuit breaker panel located in the equipment room and a sub-circuit breaker panel located between the toilet rooms. Panels are clearly labeled as to what each breaker serves. All wiring is run in conduit. Main circuit breaker panel was installed in 1992, and the sub-circuit breaker panel in 1980.

Lighting fixtures in the building are a mix of surface mounted incandescent and fluorescent fixtures. Indoor lighting fixtures were installed in 1992.

Outdoor lighting is primarily high pressure sodium or HID. Surface mounted fixtures are used on the building. Most outdoor lighting has been in service since 1992.

Hand dryers are electric and operating properly.

CCTV is installed in the lobby. There is also an emergency beacon system, the operation of which was not immediately observable, but confirmed by staff.

Telephone and internet services are installed in the building.

E. Sanitary Sewer System

The sanitary sewer system consists of gravity flow sewer lines to two sewage lagoons located at the south end of the site. Both lagoons are approximately the same size and were re-lined and rippapped in 2011.

According to maintenance personnel, the ponds provide adequate capacity. The age and material of the pipe is unknown, but no problems have been detected with the system at this time.

F. Water System

The water source for this site is rural water with meter and an underground tank. No problems were identified with this system.



G. Infrastructure

The parking area is concrete. The general condition of the concrete for the ramps and the parking area is good, with observed deterioration being in the joints. Quite a bit of corner cracking is also evident. The latest pavement rating sheet for this rest area indicates lower scores for joint spalling and joint seal damage but does not indicate a low score for corner cracking. Approximately 5% of the panels will need to be replaced in the near future. Joint and crack repair and sealing should be done as regular maintenance.

Concrete walk extends along the parking spaces, around the building and to picnic shelters located around the site. The majority of the concrete sidewalk is in good shape. Approximately 15% of the sidewalk has cracks that may require replacement in the future. Mudjacking of the walk around the building has been done.



IV. SUMMARY

The Hidewood North Rest Area is located along Interstate 29, near the town of Watertown South Dakota. The facility is located approximately 18 miles southeast of Watertown and 28 miles north of Brookings, South. The rest area has direct access to and from Interstate 29 servicing north bound traffic. It also includes a small overlook site and marker.

The purpose of this report was to summarize the condition of existing site components and building systems for the facility as a whole, and to define the general status of the existing facilities given their age and use.

The site is substantial with significant vacant area to allow for expansion in the future. Given that it has been many years (1988) since any major improvements have been made, a refurbishment of the facilities and site components will be required in the years ahead. The facility itself is in average shape, and may require immediate repairs to the heating and ventilating system and the lighting systems.

The facility will need to be modified to comply with ADA/building code requirements. The extent of which has yet to be determined, as an additional factor will be in identifying the added space required to modify the restroom entrances, to support increased user loads (if any), and to provide family assist restroom(s).



The Interstate Rest Areas Study: Along the I-29 and I-90 Corridors

APPENDIX A MAINTENANCE STAFF MEETING MINUTES



October 15, 2013

MEETING MINUTES

SDDOT INTERSTATE REST AREA STUDY

FHU Reference No. 113039-01

Hidewood Northbound Maintenance Review Meeting

Hidewood Northbound Rest Area

Date of Meeting: September 17, 2013

In attendance:

- Brad Remmich – SDDOT
 - Brian Wacholz – SDDOT
 - Tim Roach – TSP
 - Bob King – TSP
 - Todd Schultz - TSP
-

The purpose of the meeting was to gain initial insights from the SDDOT maintenance team about the operation, history, and condition of the existing on-site facilities at the Hidewood North rest area. The following summarizes the key points of the meeting:

FACILITY USE

- There is a consistent year round activity at the facilities from truckers, and local commuters. In the summer, there is increase in tourist use. The facility will likely be impacted by an increase in trucking to and from the North Dakota Oil Fields, and associated population growth.
- Per the SDDOT, at this time the facility seems to be appropriately sized for the current use.
- The facility seems to be limited in interior circulation space for both the restrooms and the visitor's area. The restrooms comfortably support perhaps 3-4 people at a time, but there is little maneuvering space.
- The picnic shelters are used regularly during the summer months (June – August) but are never full.
- Per the SDDOT, the visitor and camper parking area is sufficiently sized, and the truck parking, area, which is in a separate lot, needs to be expanded and made a bit more accessible.

USER INFORMATION

- There are a fairly balanced proportion of general travelers and truckers at this location. The dumping station is fairly often used, more by locals. Truckers do overnight at this location, most often this facility is an overflow facility when near buy truck stops are full.

FACILITY NEEDS / ISSUES

- There have been some consistent complaints at this location which include:
 - Poor lighting in restrooms
 - No Family bathrooms provided.

- Expanded truck parking needed.
- There have been no safety or security issues reported. The provision of a video monitor system was very successful in reducing vandalism and security problems in the past but it isn't working well. The system is old and only a few of the cameras are in working order. Adding a viewing monitor in the lobby may improve awareness of security.
- There is no known history of accidents related to current facility and on site circulation.
- Site Systems (landscaping, lighting, trash, ponds, etc.):
 - Sidewalk and paving maintenance repairs needed but otherwise surfaces are in good condition.
 - Lagoon System was relined and ripped in 2011.
 - Rural water supply system and infrastructure in good shape with new fiberglass storage tank. No issues with piping and pumps.
 - The lawn sprinkler system will need replacement.
 - Propane tanks system in good shape, there are two underground tanks.
 - Site parking, pedestrian, and exterior building lighting systems are original and are becoming unruly and expensive to maintain. Need replacement ASAP.
 - Site drainage is excellent, and there isn't a history of ponding or flooding.
 - Dog walk area has heavy use, could use baggie stand to assist and encourage user pick up and disposal of dog waste.
- Building Systems (shell, interior finishes, MEP):
 - Upgrade to ADA.
 - Replace video camera system.
 - Replace aged water closet and urinal. Manual flush valves with sensor type or ADA compliant manual flush valves.
 - Replace cedar shingle roof system on main building and picnic shelters.
 - Heat, Cooling, and Ventilation system is in good condition, approximately 5 years old.
 - Electrical power seems to be adequate for the connected loads. Power system may need to be upgraded for any future additional electrical loads.
 - Interior Lighting is adequate – maintenance cost for lamps may justify replacement of fixtures.
 - Bathroom exhaust and make-up air system is adequate.
 - Heating, Cooling, and ventilation are adequate at this facility.
 - Domestic water heater, gas fired storage type, is adequate.
 - Water softener system is adequate.

SDDOT MAINTENANCE STAFF REQUESTS

- No additional requests were made.

These meeting minutes were prepared by Tim Roach (TSP). Please contact me at roachtj@teamtsp.com or 605-343-6102 for corrections or clarifications.



The Interstate Rest Areas Study: Along the I-29 and I-90 Corridors

APPENDIX B ADA SURVEY RESULTS

SDDOT Rest Area Improvements
FHU Reference Number 13-039-01
TSP Project Number 03120855

Building **HIDEWOOD NORTH**

Location **29 N., MRM 160**

Date **09-17-2013 (Inspection)**

ADA Checklist for Readily Achievable Barrier Removal

Priority 1 – Approach & Entrance



SDDOT Rest Area Improvements

FHU Reference Number 13-039-01

TSP Project Number 03120855

Project

Building **HIDEWOOD NORTH**

Location **29 N., MRM 160**

Date **09-17-2013 (Inspection)**

Surveyors **Timothy Roach, AIA**
Todd Schultz, PE

Robert King, CPD

Contact Information **TSP (605) 343-6102**

An accessible route from site arrival points and an accessible entrance should be provided for everyone.



Institute for Human Centered Design
www.HumanCenteredDesign.org

November 2011



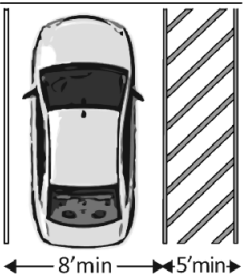
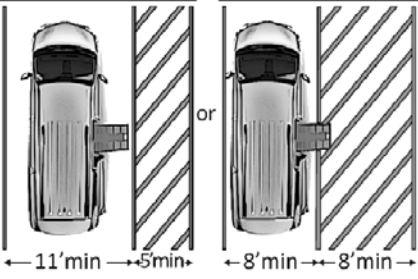
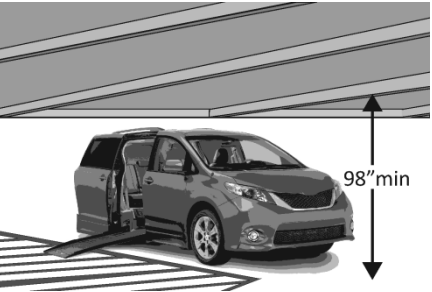
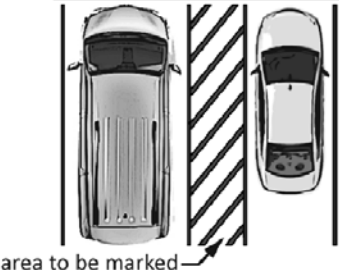
ADA National Network
Questions on the ADA 800-949-4232 voice/tty
www.ADAchecklist.org


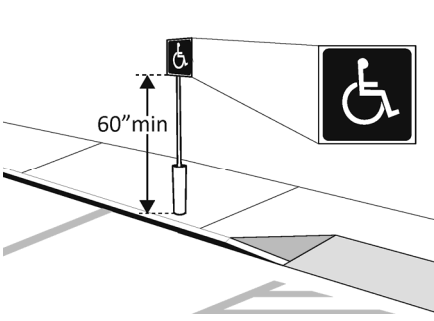
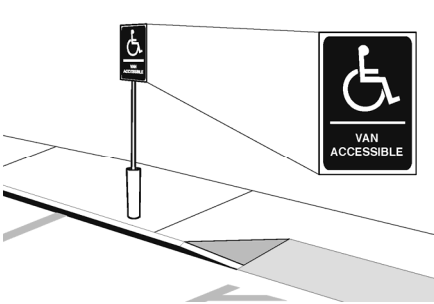
This checklist was produced by the New England ADA Center, a project of the Institute for Human Centered Design and a member of the ADA National Network. This checklist was developed under a grant from the Department of Education, NIDRR grant number H133A060092-09A. However the contents do not necessarily represent the policy of the Department of Education, and you should not assume endorsement by the Federal Government.

Questions or comments on the checklist contact the New England ADA Center at 617-695-0085 voice/tty or ADAinfo@NewEnglandADA.org

For the full set of checklists, including the checklists for recreation facilities visit www.ADAchecklist.org.

Priority 1 – Approach & Entrance		Comments	Possible Solutions												
<p>1.1 Is there at least one route from site arrival points (parking, passenger loading zones, public sidewalks and public transportation stops) that does not require the use of stairs?</p>	<p><input checked="" type="checkbox"/> Yes <input type="checkbox"/> No</p> <p>If yes, location of route:</p>	<p>Photo #: 1.1</p>	<ul style="list-style-type: none"> • Add a ramp • Regrade to 1:20 maximum slope • Add a lift if site constraints prevent other solutions 												
<p>Parking (2010 Standards – 208 & 502) Note: Accessible parking spaces should be identified by size, access aisle and signage.</p>															
<p>1.2 If parking is provided for the public, are an adequate number of accessible spaces provided?</p>	<p><input checked="" type="checkbox"/> Yes <input type="checkbox"/> No</p> <p>Total #: 24</p> <p>Accessible #: 2</p>	<table border="1"> <thead> <tr> <th>Total Spaces</th> <th>Accessible Spaces</th> </tr> </thead> <tbody> <tr> <td>1 - 25</td> <td>1</td> </tr> <tr> <td>26 - 50</td> <td>2</td> </tr> <tr> <td>51 - 75</td> <td>3</td> </tr> <tr> <td>76 - 100</td> <td>4</td> </tr> <tr> <td colspan="2">100+ see 2010 Standards 208.2</td> </tr> </tbody> </table> <p>Photo #: 1.2</p>	Total Spaces	Accessible Spaces	1 - 25	1	26 - 50	2	51 - 75	3	76 - 100	4	100+ see 2010 Standards 208.2		<ul style="list-style-type: none"> • Reconfigure by repainting lines • •
Total Spaces	Accessible Spaces														
1 - 25	1														
26 - 50	2														
51 - 75	3														
76 - 100	4														
100+ see 2010 Standards 208.2															
<p>1.3 Of the accessible spaces, is at least one a van accessible space?*</p>	<p><input type="checkbox"/> Yes <input checked="" type="checkbox"/> No</p>	<p>*For every 6 or fraction of 6 parking spaces required by the table above, at least 1 should be a van accessible space.</p> <p>Photo #: 1.3</p>	<p>* If constructed before 3/15/2012, parking is compliant if at least 1 in every 8 accessible spaces is van accessible</p> <ul style="list-style-type: none"> • Reconfigure by repainting lines 												


<p>1.4 Are accessible spaces at least 8 feet wide with an access aisle at least 5 feet wide?</p>	<p><input checked="" type="checkbox"/> Yes <input type="checkbox"/> No</p> <p>Measurement: 8 FT SPACE 8 FT AISLE</p>		<p>Photo #: 1.2</p>	<ul style="list-style-type: none"> • Reconfigure by repainting lines <p>Two spaces can share an access aisle (check state requirements; some states, such as Connecticut, require an access aisle for each space)</p>
<p>1.5 Is the van accessible space: At least 11 feet wide with an access aisle at least 5 feet wide? Or At least 8 feet wide with an access aisle at least 8 feet wide?</p>	<p><input type="checkbox"/> Yes <input type="checkbox"/> No</p> <p>Measurement:</p> <p><input type="checkbox"/> Yes <input type="checkbox"/> No</p> <p>Measurement:</p>		<p>Photo #: NA</p>	<ul style="list-style-type: none"> • Reconfigure to provide van-accessible space(s) • •
<p>1.6 Is at least 98 inches of vertical clearance provided for the van accessible space?</p>	<p><input type="checkbox"/> Yes <input type="checkbox"/> No</p> <p>Measurement:</p>		<p>Photo #: NA</p>	<ul style="list-style-type: none"> • Reconfigure to provide van-accessible space(s) • •
<p>1.7 Are the access aisles marked so as to discourage parking in them?</p>	<p><input checked="" type="checkbox"/> Yes <input type="checkbox"/> No</p>		<p>Photo #: 1.7</p>	<ul style="list-style-type: none"> • Mark access aisles • • <p>The marking method and color may be addressed by state/local requirements</p>

<p>1.8 Is the slope of the accessible parking spaces and access aisles no steeper than 1:48 in all directions?</p>	<p><input checked="" type="checkbox"/> Yes <input type="checkbox"/> No</p> <p>Measurement: <2%</p>		<p>Photo #:</p>	<ul style="list-style-type: none"> • Regrade surface • •
<p>1.9 Do the access aisles adjoin an accessible route?</p>	<p><input checked="" type="checkbox"/> Yes <input type="checkbox"/> No</p>		<p>Photo #: 1.1</p>	<ul style="list-style-type: none"> • Create accessible route • Relocate accessible space •
<p>1.10 Are accessible spaces Identified with a sign that includes the International Symbol of Accessibility?</p> <p>Is the bottom of the sign at least 60 inches above the ground?</p>	<p><input checked="" type="checkbox"/> Yes <input type="checkbox"/> No</p> <p><input checked="" type="checkbox"/> Yes <input type="checkbox"/> No</p> <p>Measurement: 70"</p>		<p>Photo #: 1.3</p>	<ul style="list-style-type: none"> • Install signs • • <p>The International Symbol of Accessibility is not required on the ground by the 2010 Standards</p>
<p>1.11 Are there signs reading “van accessible” at van accessible spaces?</p>	<p><input type="checkbox"/> Yes <input checked="" type="checkbox"/> No</p>		<p>NA</p> <p>Photo #:</p>	<ul style="list-style-type: none"> • Install signs • •

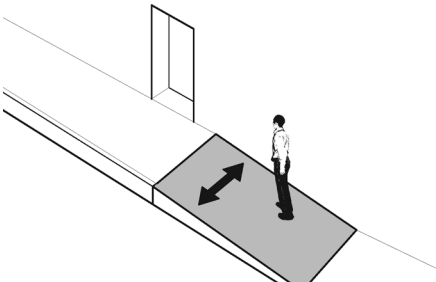
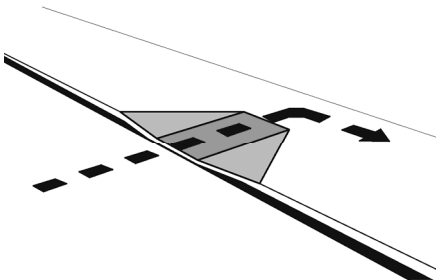
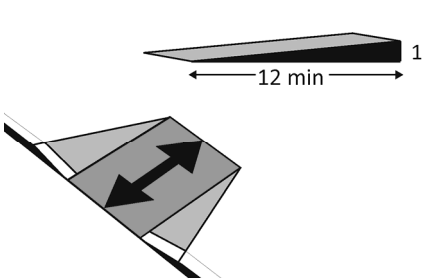
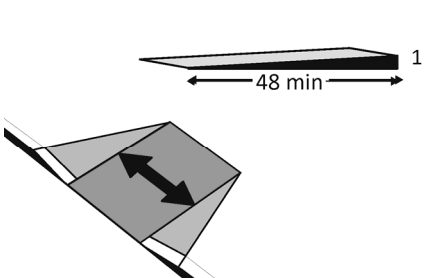
<p>1.12 Of the total parking spaces, are the accessible spaces located on the closest accessible route to the accessible entrance(s)?</p>	<p><input type="checkbox"/> Yes <input checked="" type="checkbox"/> No</p>		<p>CLOSEST ROUTE IS SLIGHTLY STEEPER THAN 5%</p> <p>Photo #:</p>	<ul style="list-style-type: none"> • Reconfigure spaces • • <p>If parking lot serves multiple entrances, accessible parking should be dispersed</p>
--	--	--	---	--

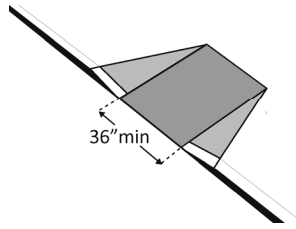
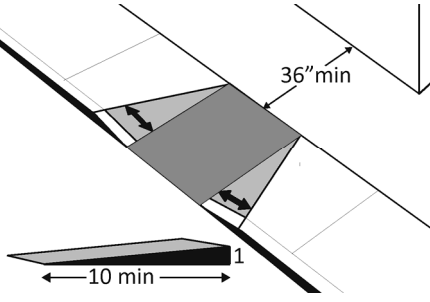
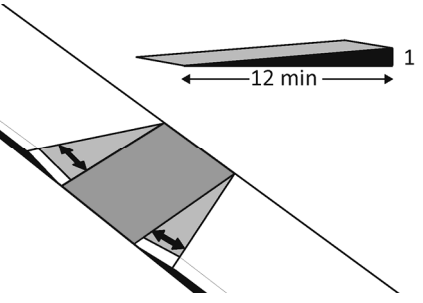
Exterior Accessible Route (2010 Standards – Ch.4)

<p>1.13 Is the route stable, firm and slip-resistant?</p>	<p><input checked="" type="checkbox"/> Yes <input type="checkbox"/> No</p>		<p>Photo #: 1.13</p>	<ul style="list-style-type: none"> • Repair uneven paving • Fill small bumps and breaks with patches • Replace gravel with asphalt or other surface
--	--	--	-----------------------------	--

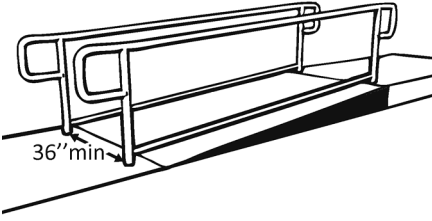
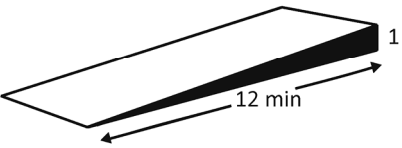
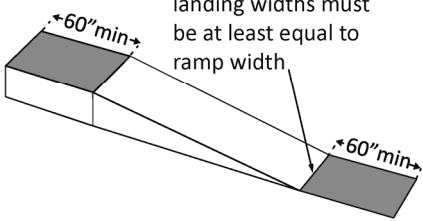
<p>1.14 Is the route at least 36 inches wide?</p> <p>Note: The accessible route can narrow to 32 inches min. for a max. of 24 inches. These narrower portions of the route must be at least 48 inches from each other.</p>	<p><input checked="" type="checkbox"/> Yes <input type="checkbox"/> No</p> <p>Measurement: 70"</p>			<ul style="list-style-type: none"> • Change or move landscaping, furnishings or other items • Widen route •
---	---	--	--	--

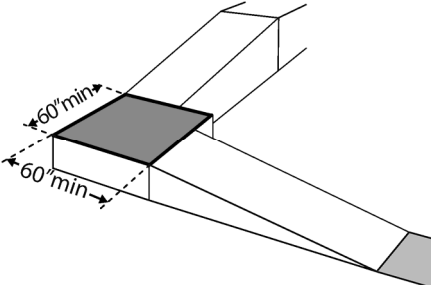
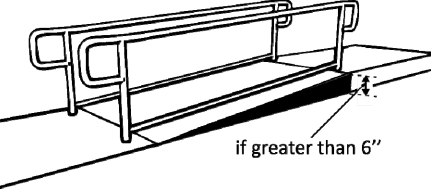
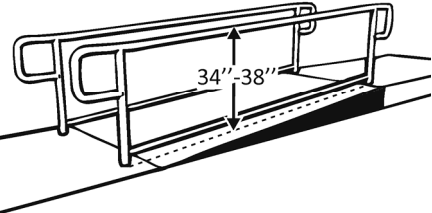
			<p>Photo #: 1.14</p>	
<p>1.15 If the route is greater than 200 feet in length and no less than 60 inches wide, is there a passing space no less than 60 x 60 inches?</p>	<p><input type="checkbox"/> Yes <input type="checkbox"/> No</p> <p>Measurement: NA</p>		<p>NA</p> <p>Photo #:</p>	<ul style="list-style-type: none"> • Widen route for passing space • •
<p>1.16 If there are grates or openings on the route, are the openings no larger than 1/2 inches to the dominant direction of travel?</p> <p>Is the long dimension perpendicular to the dominant direction of travel?</p>	<p><input type="checkbox"/> Yes <input checked="" type="checkbox"/> No</p> <p>Measurement: NA</p> <p><input type="checkbox"/> Yes <input type="checkbox"/> No</p>		<p>Photo #:</p>	<ul style="list-style-type: none"> • Replace or move grate • •
<p>1.17 Is the running slope no steeper than 1:20, i.e. for every inch of height change there are at least 20 inches of route run?</p>	<p><input checked="" type="checkbox"/> Yes <input type="checkbox"/> No</p> <p>Measurement: <5.0%</p>		<p>Photo #:</p>	<ul style="list-style-type: none"> • Regrade to 1:20 max. • If steeper than 1:20 and no steeper than 1:12, treat as a ramp and add other features such as edge protection and handrails •

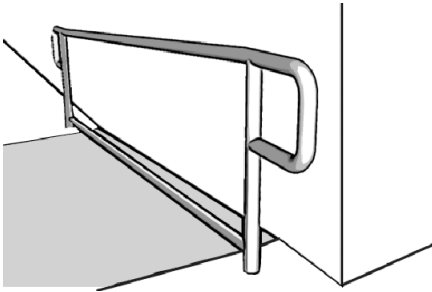
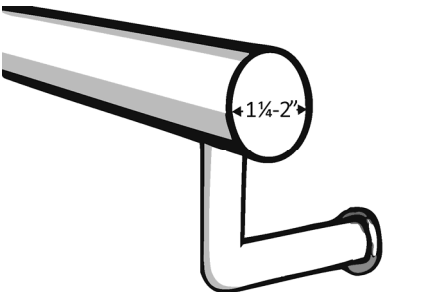
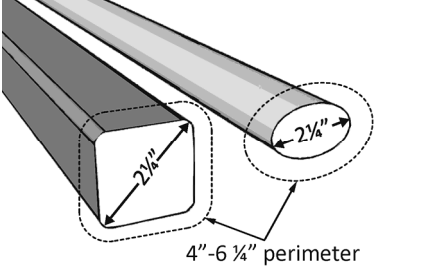
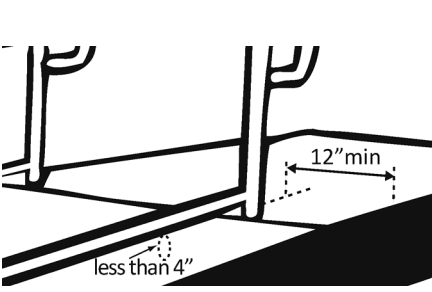
<p>1.18 Is the cross slope no steeper than 1:48?</p>	<p><input checked="" type="checkbox"/> Yes <input type="checkbox"/> No</p> <p>Measurement: <2%</p>		<p>Photo #:</p>	<ul style="list-style-type: none"> • Regrade to 1:48 max. • •
<p>Curb Ramps (2010 Standards – 406)</p>				
<p>1.19 If the accessible route crosses a curb, is there a curb ramp?</p>	<p><input checked="" type="checkbox"/> Yes <input type="checkbox"/> No</p>		<p>Photo #: 1.14</p>	<ul style="list-style-type: none"> • Install curb ramp • •
<p>1.20 Is the running slope of the curb ramp no steeper than 1:12, i.e. for every inch of height change there are at least 12 inches of curb ramp run?</p>	<p><input checked="" type="checkbox"/> Yes <input type="checkbox"/> No</p> <p>Measurement: <1:12</p>		<p>Photo #:</p>	<ul style="list-style-type: none"> • Regrade curb ramp • •
<p>1.21 Is the cross slope of the curb ramp, excluding flares, no steeper than 1:48?</p>	<p><input checked="" type="checkbox"/> Yes <input type="checkbox"/> No</p> <p>Measurement: 6" IN 6'</p>		<p>Photo #: 1.14</p>	<ul style="list-style-type: none"> • Regrade curb ramp • •

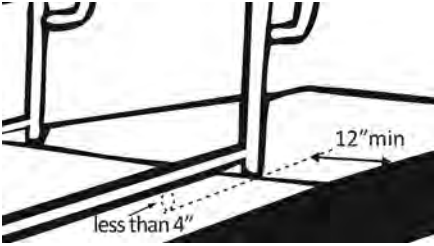

<p>1.22 Is the curb ramp, excluding flares, at least 36 inches wide?</p>	<p><input checked="" type="checkbox"/> Yes <input type="checkbox"/> No</p> <p>Measurement:</p>		<p>Photo #: 1.14</p>	<ul style="list-style-type: none"> • Widen curb ramp • •
<p>1.23 At the top of the curb ramp is there a level landing (slope no steeper than 1:48 in all directions) that is at least 36 inches long and at least as wide as the curb ramp? If there are curb ramp flares, are the slopes of the flares no steeper than 1:10, i.e. for every inch of height change there are at least 10 inches of flare run?</p>	<p><input checked="" type="checkbox"/> Yes <input type="checkbox"/> No</p> <p>Measurement: <2% 4'WIDE</p> <p><input checked="" type="checkbox"/> Yes <input type="checkbox"/> No</p> <p>Measurement:</p>		<p>Photo #: 1.14</p>	<ul style="list-style-type: none"> • Reconfigure • Add ramp flares •
<p>1.24 If the landing at the top is less than 36 inches long, are there curb ramp flares? Are the slopes of the flares no greater than 1:12, i.e. for every inch of height change there are at least 12 inches of flare run?</p>	<p><input type="checkbox"/> Yes <input type="checkbox"/> No</p> <p><input type="checkbox"/> Yes <input type="checkbox"/> No</p> <p>Measurement:</p>		<p>NA</p> <p>Photo #:</p>	<ul style="list-style-type: none"> • Add ramp flares • Regrade flares •

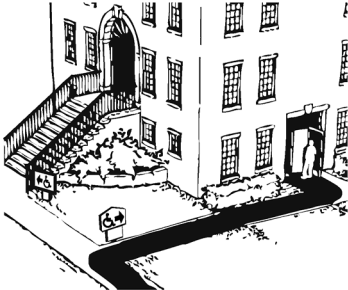
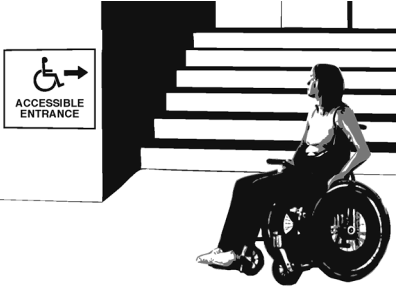

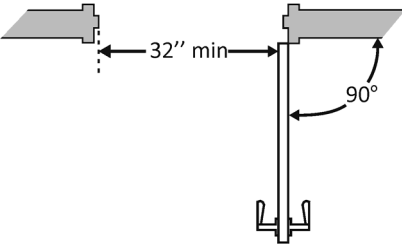
Ramps (2010 Standards – 405 & 505) Note: If any portion of the accessible route is steeper than 1:20, it should be treated as a ramp.

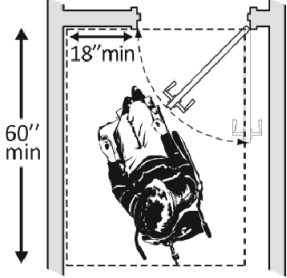
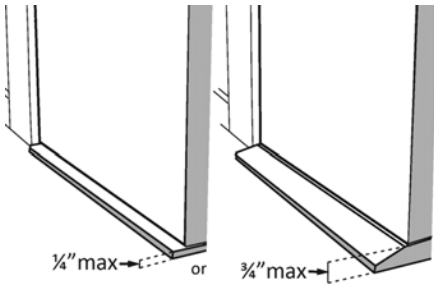
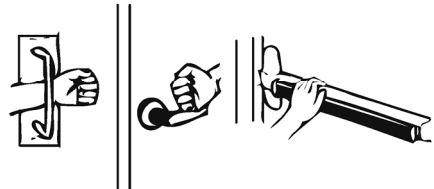
<p>1.25 If there is a ramp (other than curb ramps), is it at least 36 inches wide? If there are handrails, measure between the handrails.</p>	<p><input type="checkbox"/> Yes <input type="checkbox"/> No</p> <p>Measurement:</p> <p>NA</p>		<p>Photo #:</p>	<ul style="list-style-type: none"> • Alter ramp • •
<p>1.26 Is the surface stable, firm and slip resistant?</p>	<p><input type="checkbox"/> Yes <input type="checkbox"/> No</p> <p>NA</p>		<p>Photo #:</p>	<ul style="list-style-type: none"> • Resurface ramp • •
<p>1.27 For each section of the ramp, is the running slope no greater than 1:12, i.e. for every inch of height change there are at least 12 inches of ramp run? Note: Rises no greater than 3 inches with a slope no steeper than 1:8 and rises no greater than 6 inches with a slope no steeper than 1:10 are permitted when such slopes are necessary due to space limitations.</p>	<p><input type="checkbox"/> Yes <input type="checkbox"/> No</p> <p>Measurement:</p> <p>NA</p>		<p>Photo #:</p>	<ul style="list-style-type: none"> • Alter or relocate ramp • Lengthen ramp to decrease slope •
<p>1.28 Is there a level landing that is at least 60 inches long and at least as wide as the ramp: At the top of the ramp?</p>	<p><input type="checkbox"/> Yes <input type="checkbox"/> No</p> <p>Measurement:</p>		<p>NA</p>	<ul style="list-style-type: none"> • Alter ramp • •

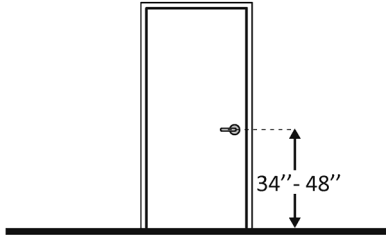
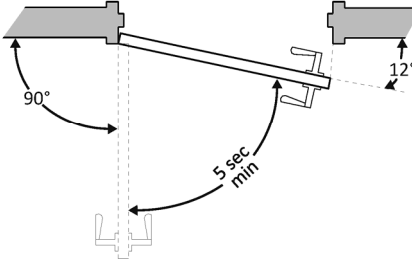
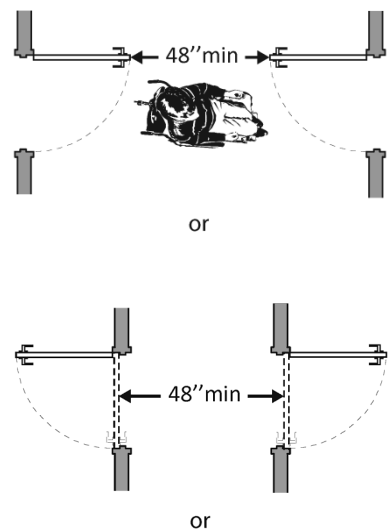
<p>At the bottom of the ramp?</p>	<p><input type="checkbox"/> Yes <input type="checkbox"/> No</p> <p>Measurement:</p>		<p>Photo #:</p>	
<p>1.29 Is there a level landing where the ramp changes direction that is at least 60 x 60 inches?</p>	<p><input type="checkbox"/> Yes <input type="checkbox"/> No</p> <p>Measurement:</p>		<p>Photo #:</p> <p style="text-align: center; color: red; font-weight: bold;">NA</p>	<ul style="list-style-type: none"> • Alter ramp • •
<p>1.30 If the ramp has a rise higher than 6 inches, are there handrails on both sides?</p>	<p><input type="checkbox"/> Yes <input type="checkbox"/> No</p> <p>Measurement:</p>		<p>Photo #:</p> <p style="text-align: center; color: red; font-weight: bold;">NA</p>	<ul style="list-style-type: none"> • Add handrails • • <p>Curb ramps are not required to have handrails</p>
<p>1.31 Is the top of the handrail gripping surface no less than 34 inches and no greater than 38 inches above the ramp surface?</p>	<p><input type="checkbox"/> Yes <input type="checkbox"/> No</p> <p>Measurement:</p>		<p>Photo #:</p> <p style="text-align: center; color: red; font-weight: bold;">NA</p>	<ul style="list-style-type: none"> • Reconfigure or replace handrails • •

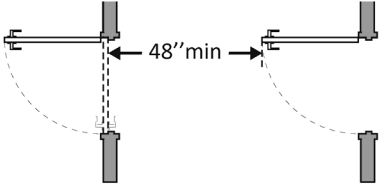

<p>1.32 Is the handrail gripping surface continuous and not obstructed along the top or sides?</p> <p>Is the bottom of the handrail gripping surface obstructed for no more than 20 percent of its length?</p>	<p><input type="checkbox"/> Yes <input type="checkbox"/> No</p> <p><input type="checkbox"/> Yes <input type="checkbox"/> No</p> <p>Measurement:</p>		<p style="text-align: center; color: red; font-weight: bold;">NA</p> <p>Photo #:</p>	<ul style="list-style-type: none"> • Reconfigure or replace handrails • •
<p>1.33 If the handrail gripping surface is circular, is it no less than 1 ¼ inches and no greater than 2 inches in diameter?</p>	<p><input type="checkbox"/> Yes <input type="checkbox"/> No</p> <p>Measurement:</p>		<p style="text-align: center; color: red; font-weight: bold;">NA</p> <p>Photo #:</p>	<ul style="list-style-type: none"> • Replace handrails • •
<p>1.34 If the handrail gripping surface is non-circular, is it no less than 4 inches and no greater than 6 ½ inches in perimeter and no more than 2 ¼ inches in cross section?</p>	<p><input type="checkbox"/> Yes <input type="checkbox"/> No</p> <p>Measurement:</p>		<p style="text-align: center; color: red; font-weight: bold;">NA</p> <p>Photo #:</p>	<ul style="list-style-type: none"> • Replace handrails • •
<p>1.35 Does the handrail:</p> <p>Extend at least 12 inches horizontally beyond the top and bottom of the ramp?</p> <p>Return to a wall, guard, or landing surface?</p>	<p><input type="checkbox"/> Yes <input type="checkbox"/> No</p> <p>Measurement:</p> <p><input type="checkbox"/> Yes <input type="checkbox"/> No</p>		<p style="text-align: center; color: red; font-weight: bold;">NA</p> <p>Photo #:</p>	<ul style="list-style-type: none"> • Add extensions • Reconfigure handrails •

<p>1.36 To prevent wheelchair casters and crutch tips from falling off:</p> <p>Does the surface of the ramp extend at least 12 inches beyond the inside face of the handrail? <input type="checkbox"/> Yes <input type="checkbox"/> No</p> <p>Measurement:</p> <p>Or</p> <p>Is there a curb or barrier that prevents the passage of a 4-inch diameter sphere? <input type="checkbox"/> Yes <input type="checkbox"/> No</p> <p>Measurement:</p>	<p><input type="checkbox"/> Yes <input type="checkbox"/> No</p> <p>Measurement:</p> <p><input type="checkbox"/> Yes <input type="checkbox"/> No</p> <p>Measurement:</p>		<p style="text-align: center;">NA</p> <p>Photo #:</p>	<ul style="list-style-type: none"> • Add curb • Add barrier • Extend ramp width •
<p>Entrance (2010 Standards – 404)</p>				
<p>1.37 Is the main entrance accessible?</p>	<p>Yes <input checked="" type="checkbox"/> No</p>		<p>Requires hardware modifications</p> <p>Photo #: 2.1</p>	<ul style="list-style-type: none"> • Redesign to make it accessible • •
<p>1.38 If the main entrance is not accessible, is there an alternative accessible entrance?</p> <p>Can the alternative accessible entrance be used independently and during the same hours as the main entrance?</p>	<p><input type="checkbox"/> Yes <input type="checkbox"/> No</p> <p><input type="checkbox"/> Yes <input type="checkbox"/> No</p>		<p style="text-align: center;">NA</p>	<ul style="list-style-type: none"> • Designate an entrance and make it accessible • Ensure that accessible entrance can be used independently and during the same hours as the main entrance •

			<p>Photo #:</p>	
<p>1.39 Do all inaccessible entrances have signs indicating the location of the nearest accessible entrance?</p>	<p><input type="checkbox"/> Yes <input type="checkbox"/> No</p>		<p>Photo #: NA</p>	<ul style="list-style-type: none"> • Install signs • Install signs on route before people get to inaccessible entrances so that people do not have to turn around and retrace route •
<p>1.40 If not all entrances are accessible, is there a sign at the accessible entrance with the International Symbol of Accessibility?</p>	<p><input type="checkbox"/> Yes <input type="checkbox"/> No</p>		<p>Photo #: NA</p>	<ul style="list-style-type: none"> • Install sign • •
<p>1.41 Is the clear opening width of the accessible entrance door at least 32 inches, between the face of the door and the stop, when the door is open 90 degrees?</p>	<p><input checked="" type="checkbox"/> Yes <input type="checkbox"/> No</p> <p>Measurement:</p> <p>34"</p>		<p>Photo #: 1.41</p>	<ul style="list-style-type: none"> • Alter door • Install offset hinges •

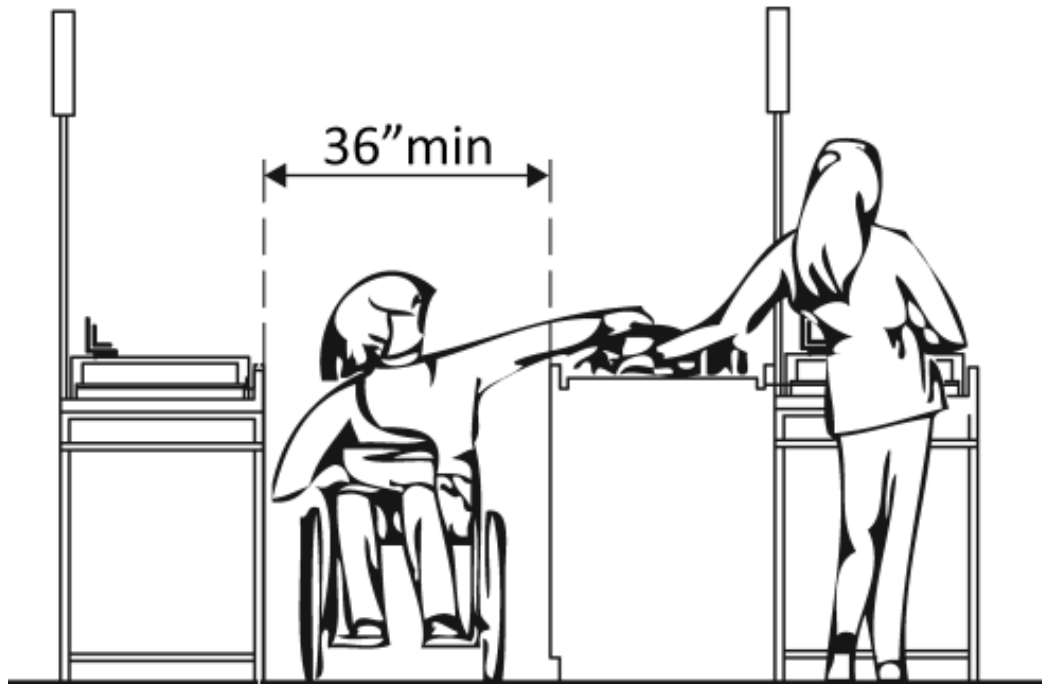
<p>1.42 If there is a front approach to the pull side of the door, is there at least 18 inches of maneuvering clearance beyond the latch side plus at least 60 inches clear depth?</p> <p>On both sides of the door, is the ground or floor surface of the maneuvering clearance level (no steeper than 1:48)?</p>	<p><input checked="" type="checkbox"/> Yes <input type="checkbox"/> No</p> <p>Measurement: 42"</p> <p><input checked="" type="checkbox"/> Yes <input type="checkbox"/> No</p> <p>Measurement:</p>		<p>Photo #: 1.42</p>	<p>See 2010 Standards 404.2.4 for maneuvering clearance requirements on the push side of the door and side approaches to the pull side of the door</p> <ul style="list-style-type: none"> • Remove obstructions • Reconfigure walls • Add automatic door opener
<p>1.43 Is the door threshold edge no more than ¼ inch high?</p> <p>Or</p> <p>No more than ¾ inch high if slope is beveled no steeper than 1:2?</p> <p>Note: The first ¼ inch of the threshold may be vertical; the rest must be beveled.</p>	<p><input checked="" type="checkbox"/> Yes <input type="checkbox"/> No</p> <p>Measurement: ¾"</p> <p><input checked="" type="checkbox"/> Yes <input type="checkbox"/> No</p> <p>Measurement:</p>		<p>Photo #: 1.43</p>	<ul style="list-style-type: none"> • Remove or replace threshold • •
<p>1.44 Is the door equipped with hardware, including locks, that is operable with one hand and does not require tight grasping, pinching, or twisting of the wrist?</p>	<p><input type="checkbox"/> Yes <input checked="" type="checkbox"/> No</p>		<p>Photo #: 1.41</p>	<ul style="list-style-type: none"> • Replace inaccessible knob with lever, loop or push hardware • Add automatic door opener •

<p>1.45 Are the operable parts of the door hardware no less than 34 inches and no greater than 48 inches above the floor or ground surface?</p>	<p><input type="checkbox"/> Yes <input checked="" type="checkbox"/> No</p> <p>Measurement: 35" – 45"</p>		<p>Photo #: 1.44</p>	<ul style="list-style-type: none"> • Change hardware height • •
<p>1.46 If the door has a closer, does it take at least 5 seconds to close from an open position of 90 degrees to a position of 12 degrees from the latch?</p>	<p><input type="checkbox"/> Yes <input checked="" type="checkbox"/> No</p> <p>Measurement: 2 SEC.</p>		<p>Photo #: 1.46</p>	<ul style="list-style-type: none"> • Adjust closer • •
<p>1.47 If there are two doors in a series, e.g. vestibule, is the distance between the doors at least 48 inches plus the width of the doors when swinging into the space?</p>	<p><input type="checkbox"/> Yes <input type="checkbox"/> No</p> <p>Measurement:</p>		<p>NA</p>	<ul style="list-style-type: none"> • Remove inner door • Change door swing •

			<p>Photo #:</p>	
<p>1.48 If provided at the building entrance, are carpets or mats no higher than ½ inch thick?</p>	<p><input type="checkbox"/> Yes <input type="checkbox"/> No</p> <p>Measurement:</p>		<p style="text-align: center;">NA</p> <p>Photo #:</p>	<ul style="list-style-type: none"> • Replace or remove mats • •
<p>1.49 Are edges of carpets or mats securely attached to minimize tripping hazards?</p>	<p><input type="checkbox"/> Yes <input type="checkbox"/> No</p>		<p style="text-align: center;">NA</p> <p>Photo #:</p>	<ul style="list-style-type: none"> • Secure carpeting or mats at edges • •

ADA Checklist for Readily Achievable Barrier Removal

Priority 2 – Access to Goods & Services



Project **SDDOT Rest Area Improvements**
FHU Reference Number 13-039-01
TSP Project Number 03120855

Building **HIDEWOOD NORTH**

Location **29 N., MRM 160**

Date **09-17-2013 (Inspection)**

Surveyors **Timothy Roach, AIA**
Todd Schultz, PE

Robert King, CPD

Contact Information **TSP – (605) 343-6102**

The layout of the building should allow people with disabilities to obtain goods and services and to participate in activities without assistance.



Institute for Human Centered Design
www.HumanCenteredDesign.org

November 2011




ADA National Network
Questions on the ADA 800-949-4232 voice/tty

www.ADAchecklist.org

This checklist was produced by the New England ADA Center, a project of the Institute for Human Centered Design and a member of the ADA National Network. This checklist was developed under a grant from the Department of Education, NIDRR grant number H133A060092-09A. However the contents do not necessarily represent the policy of the Department of Education, and you should not assume endorsement by the Federal Government.

Questions or comments on the checklist contact the New England ADA Center at 617-695-0085 voice/tty or ADAinfo@NewEnglandADA.org

For the full set of checklists, including the checklists for recreation facilities visit www.ADAchecklist.org.

Priority 2 – Access to Goods & Services		Comments	Possible Solutions
<p>2.1 Does the accessible entrance provide direct access to the main floor, lobby and elevator?</p>	<p><input checked="" type="checkbox"/> Yes <input type="checkbox"/> No</p>	<p>Photo #: 2.1</p>	<ul style="list-style-type: none"> • Create accessible route • •
<p>Interior Accessible Route (2010 Standards – Ch.4)</p>			
<p>2.2 Are all public spaces on at least one accessible route?</p>	<p>Yes <input checked="" type="checkbox"/> No</p>	<p>Mens & Womens doorways have insufficient side clearance</p> <p>Photo #: 2.2</p>	<ul style="list-style-type: none"> • Create accessible route • •
<p>2.3 Is the route stable, firm and slip-resistant?</p>	<p><input checked="" type="checkbox"/> Yes <input type="checkbox"/> No</p>	<p>Photo #: 2.2</p>	<ul style="list-style-type: none"> • Repair uneven surfaces • •
<p>2.4 Is the route at least 36 inches wide?</p> <p>Note: The accessible route can narrow to 32 inches min. for a max. of 24 inches. These narrower portions of the route must be at least 48 inches from each other.</p>	<p><input checked="" type="checkbox"/> Yes <input type="checkbox"/> No</p> <p>Measurement: 94"</p>		<ul style="list-style-type: none"> • Widen route • •

			<p>Photo #: 2.4</p>	
<p>2.5 If the route is greater than 200 feet in length and no less than 36 inches wide, is there a passing space no less than 60 x 60 inches?</p>	<p><input type="checkbox"/> Yes <input type="checkbox"/> No Measurement:</p>		<p>NA Photo #:</p>	<ul style="list-style-type: none"> • Widen route for passing space • •
<p>2.6 Is the running slope no steeper than 1:20, i.e. for every inch of height change there are at least 20 inches of route run?</p>	<p><input type="checkbox"/> Yes <input type="checkbox"/> No Measurement:</p>		<p>NA Photo #:</p>	<ul style="list-style-type: none"> • Regrade • If steeper than 1:20 and no steeper than 1:12, treat as ramp and add other features such as edge protection and handrails •
<p>2.7 Is the cross slope no steeper than 1:48?</p>	<p><input type="checkbox"/> Yes <input type="checkbox"/> No Measurement:</p>		<p>NA Photo #:</p>	<ul style="list-style-type: none"> • Regrade • •

2.8 Do all objects on circulation paths through public areas, e.g. fire extinguishers, drinking fountains, signs, etc., protrude no more than 4 inches into the path?
 Or
 If an object protrudes more than 4 inches, is the bottom leading edge at 27 inches or lower above the floor?
 Or
 Is the bottom leading edge at 80 inches or higher above the floor?

Yes No

Measurement:
18 ½"

Yes No

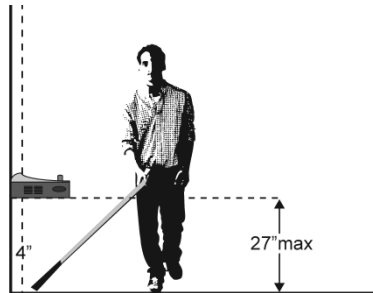
Measurement:
27"

Yes No

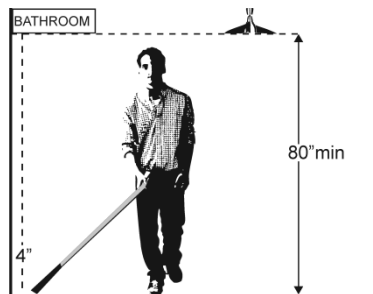
Measurement:
108"



Or



Or



ELECTRIC WATER COOLER

Photo #: **2.8 SECURITY CAMERA**

- Remove object
- Add tactile warning such as permanent planter or partial walls
-

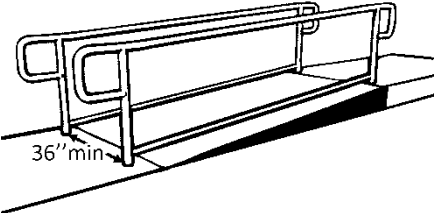
Photo #:

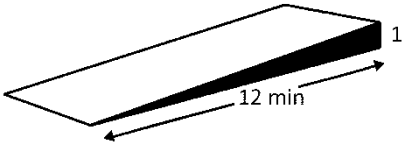
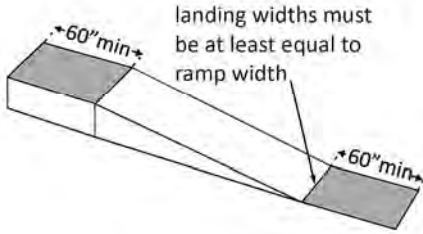
2.9 Are there elevators or platform lifts to all public stories?*

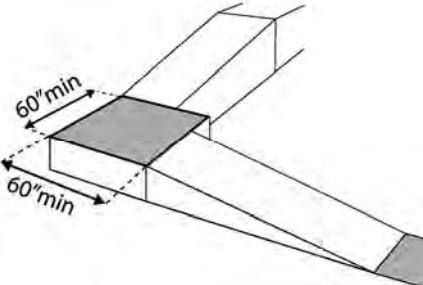
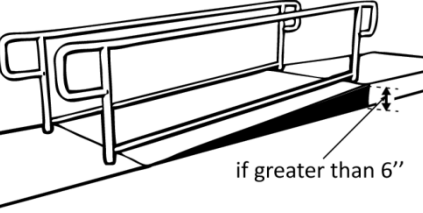
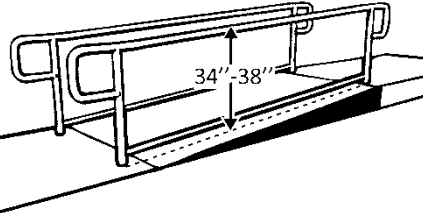
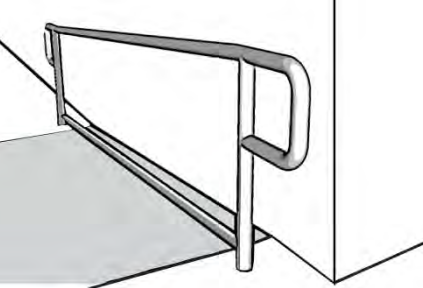
Yes No

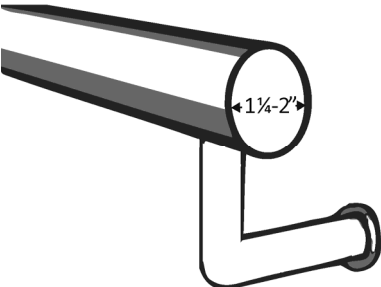
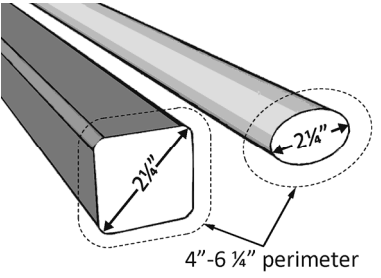
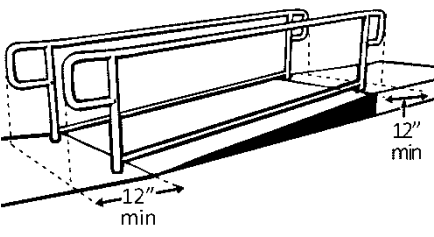
NA

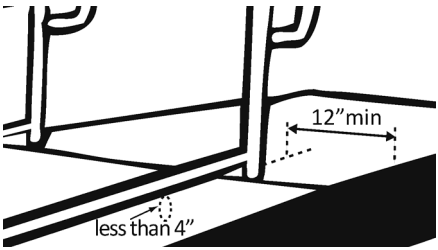
*Vertical access is not required in new construction or alterations if a facility is less than three stories or has less than 3,000

				<p>square feet per story, unless a facility is a shopping center, shopping mall, professional office of a health care provider, transportation terminal, state facility or government facility</p> <ul style="list-style-type: none"> • Install if necessary • Offer goods and services on an accessible story •
Photo #:				
Ramps (2010 Standards 404 & 505)				
<p>2.10 If there is a ramp, is it at least 36 inches wide? If there are handrails, measure between the handrails.</p>	<p><input type="checkbox"/> Yes <input type="checkbox"/> No</p> <p>Measurement:</p>		<p>NA</p>	<ul style="list-style-type: none"> • Alter ramp • •
Photo #:				
<p>2.11 Is the surface stable, firm and slip resistant?</p>	<p><input type="checkbox"/> Yes <input type="checkbox"/> No</p>		<p>NA</p>	<ul style="list-style-type: none"> • Change surface • •
Photo #:				

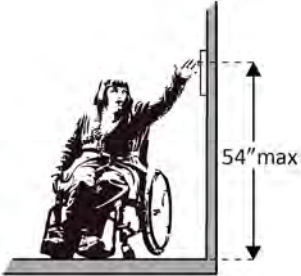
<p>2.12 For each section of the ramp, is the running slope no greater than 1:12, i.e. for every inch of height change there are at least 12 inches of ramp run?</p> <p>Note: Rises no greater than 3 inches with a slope no steeper than 1:8 and rises no greater than 6 inches with a slope no steeper than 1:10 are permitted when due to space limitations.</p>	<p><input type="checkbox"/> Yes <input type="checkbox"/> No</p> <p>Measurement:</p>		<p style="text-align: center;">NA</p> <p>Photo #:</p>	<ul style="list-style-type: none"> • Lengthen ramp to decrease slope • Reconfigure ramp to include switchbacks • Relocate ramp •
<p>2.13 Is there a level landing that is at least 60 inches long and at least as wide as the ramp:</p> <p>At the top of the ramp?</p> <p>At the bottom of the ramp?</p>	<p><input type="checkbox"/> Yes <input type="checkbox"/> No</p> <p>Measurement:</p> <p><input type="checkbox"/> Yes <input type="checkbox"/> No</p> <p>Measurement:</p>		<p style="text-align: center;">NA</p> <p>Photo #:</p>	<ul style="list-style-type: none"> • Alter ramp • Relocate ramp •

<p>2.14 Is there a level landing where the ramp changes direction that is at least 60 x 60 inches?</p>	<p><input type="checkbox"/> Yes <input type="checkbox"/> No</p> <p>Measurement:</p>		<p style="text-align: center; color: red;">NA</p> <p>Photo #:</p>	<ul style="list-style-type: none"> • Increase landing size • •
<p>2.15 If the ramp has a rise higher than 6 inches are there handrails on both sides?</p>	<p><input type="checkbox"/> Yes <input type="checkbox"/> No</p> <p>Measurement:</p>		<p style="text-align: center; color: red;">NA</p> <p>Photo #:</p>	<ul style="list-style-type: none"> • Add handrails • •
<p>2.16 Is the top of the handrail gripping surface no less than 34 inches and no greater than 38 inches above the ramp surface?</p>	<p><input type="checkbox"/> Yes <input type="checkbox"/> No</p> <p>Measurement:</p>		<p style="text-align: center; color: red;">NA</p> <p>Photo #:</p>	<ul style="list-style-type: none"> • Adjust handrail height • •
<p>2.17 Is the handrail gripping surface continuous and not obstructed along the top or sides?</p> <p>If there are obstructions, is the bottom of the handrail gripping surface obstructed by no more than 20%?</p>	<p><input type="checkbox"/> Yes <input type="checkbox"/> No</p> <p><input type="checkbox"/> Yes <input type="checkbox"/> No</p> <p>Measurement:</p>		<p style="text-align: center; color: red;">NA</p> <p>Photo #:</p>	<ul style="list-style-type: none"> • Regrade to 1:20 max • If steeper than 1:20 and no steeper than 1:12, treat as a ramp and add other features such as edge protection and handrails •

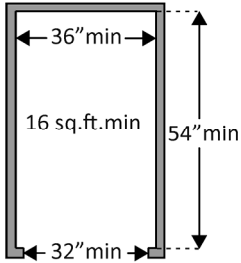
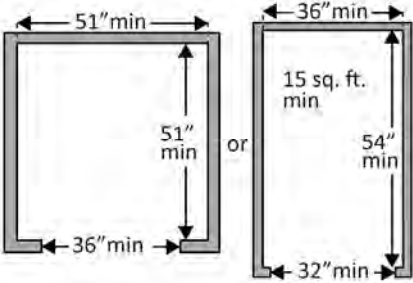
<p>2.18 If the handrail gripping surface is circular, is it no less than 1 ¼ inches and no greater than 2 inches in diameter?</p>	<p><input type="checkbox"/> Yes <input type="checkbox"/> No</p> <p>Measurement:</p>		<p style="text-align: center;">NA</p> <p>Photo #:</p>	<ul style="list-style-type: none"> • Alter handrails • •
<p>2.19 If the handrail gripping surface is non-circular, is it no less than 4 inches and no greater than 6 ½ inches in perimeter and no more than 2 ¼ inches in cross section?</p>	<p><input type="checkbox"/> Yes <input type="checkbox"/> No</p> <p>Measurement:</p>		<p style="text-align: center;">NA</p> <p>Photo #:</p>	<ul style="list-style-type: none"> • Alter handrails • •
<p>2.20 Does the handrail:</p> <p>Extend at least 12 inches beyond the top and bottom of the ramp?</p> <p>Return to a wall, guard, or landing surface?</p>	<p><input type="checkbox"/> Yes <input type="checkbox"/> No</p> <p>Measurement:</p> <p><input type="checkbox"/> Yes <input type="checkbox"/> No</p>		<p style="text-align: center;">NA</p> <p>Photo #:</p>	<ul style="list-style-type: none"> • Alter handrails • • <p>If a 12" extension would be hazardous (in circulation path), it is not required</p>

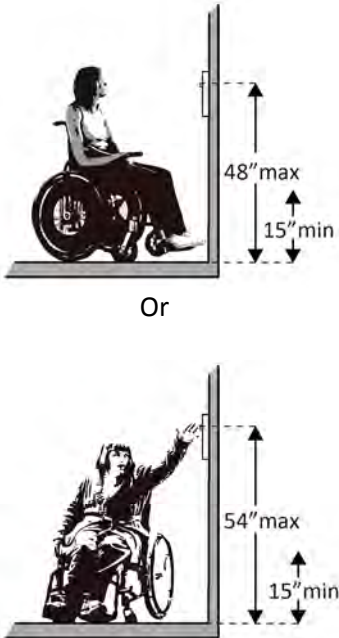

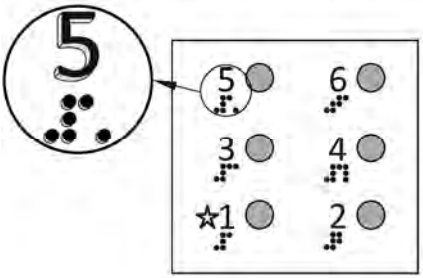
<p>2.21 To prevent wheelchair casters and crutch tips from falling off:</p> <p>Does the surface of the ramp extend at least 12 inches beyond the inside face of the handrail? Or Is there a curb or barrier that prevents the passage of a 4-inch diameter sphere?</p>	<p><input type="checkbox"/> Yes <input type="checkbox"/> No Measurement:</p> <p><input type="checkbox"/> Yes <input type="checkbox"/> No Measurement:</p>		<p style="text-align: center;">NA</p> <p>Photo #:</p>	<ul style="list-style-type: none"> • Add curb • Add barrier • Extend ramp width • •
---	---	--	--	--

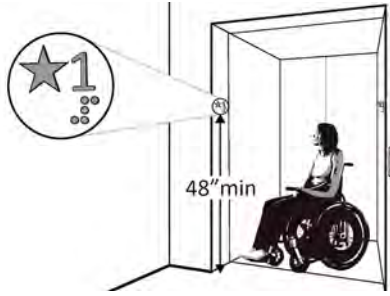
Elevators – Full Size & LULA (limited use, limited application) (2010 Standards – 407 & 408) Note: LULA elevators are often used in alterations.

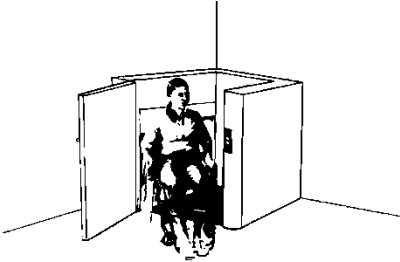
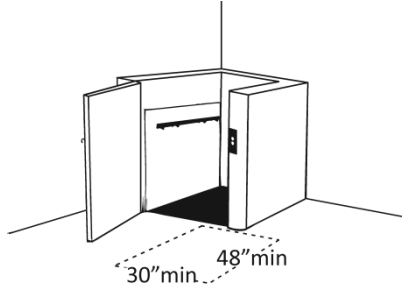
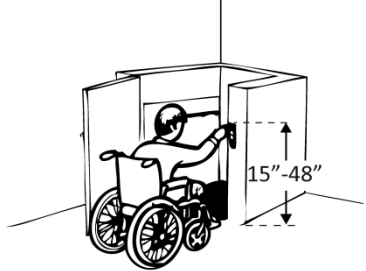
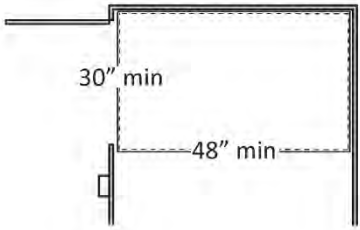
<p>2.22 If there is a full size or LULA elevator, are the call buttons no higher than 54 inches above the floor?</p>	<p><input type="checkbox"/> Yes <input type="checkbox"/> No Measurement:</p>		<p style="text-align: center;">NA</p> <p>Photo #:</p>	<ul style="list-style-type: none"> • Change call button height • •
---	--	--	--	---

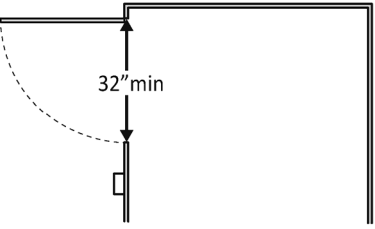
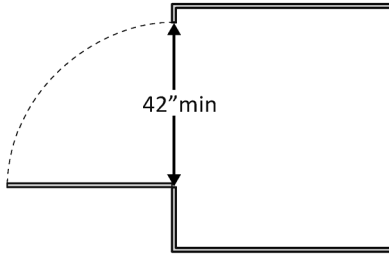
<p>2.23 If there is a full size or LULA elevator, does the sliding door reopen automatically when obstructed by an object or person?*</p>	<p><input type="checkbox"/> Yes <input type="checkbox"/> No</p>		<p style="text-align: center;">NA</p> <p>Photo #:</p>	<p>* If constructed before 3/15/2012 and manually operated, the door is not required to reopen automatically</p> <ul style="list-style-type: none"> • Install opener •
--	---	--	--	--

<p>2.24 If there is a LULA elevator with a swinging door:</p> <p>Is the door power-operated? <input type="checkbox"/> Yes <input type="checkbox"/> No</p> <p>Does the door remain open for at least 20 seconds when activated? <input type="checkbox"/> Yes <input type="checkbox"/> No</p> <p>Time:</p>			<p style="text-align: center;">NA</p> <p>Photo #:</p>	<ul style="list-style-type: none"> • Add power operated door • Adjust opening time •
<p>2.25 If there is a full size elevator:</p> <p>Is the interior at least 54 inches deep by at least 36 inches wide with at least 16 sq. ft. of clear floor area? <input type="checkbox"/> Yes <input type="checkbox"/> No</p> <p>Measurement:</p> <p>Is the door opening width at least 32 inches? <input type="checkbox"/> Yes <input type="checkbox"/> No</p> <p>Measurement:</p>			<p style="text-align: center;">NA</p> <p>Photo #:</p>	<ul style="list-style-type: none"> • Replace elevator • •
<p>2.26 If there is a LULA elevator, is the interior:</p> <p>At least 51 x 51 inches with a door opening width of at least 36 inches? <input type="checkbox"/> Yes <input type="checkbox"/> No</p> <p>Measurement:</p> <p>Or</p> <p>At least 54 inches deep by at least 36 inches wide with at least 15 sq. ft. of clear floor area and a door opening width of at least 32 inches? <input type="checkbox"/> Yes <input type="checkbox"/> No</p> <p>Measurement:</p>			<p style="text-align: center;">NA</p> <p>Photo #:</p>	<ul style="list-style-type: none"> • Replace elevator • •

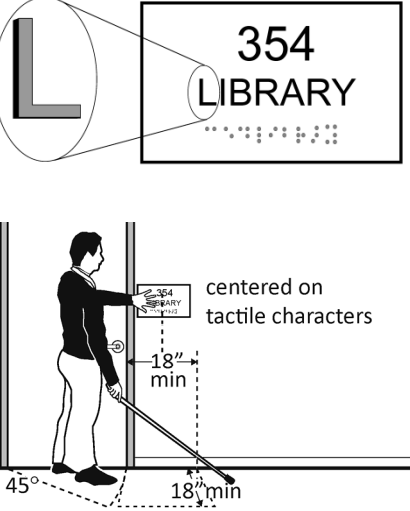
<p>2.27 If there is a full size or LULA elevator, are the in-car controls:</p> <p>No less than 15 inches and no greater 48 inches above the floor? Or Up to 54 inches above the floor for a parallel approach?</p>	<p><input type="checkbox"/> Yes <input type="checkbox"/> No Measurement:</p> <p><input type="checkbox"/> Yes <input type="checkbox"/> No Measurement:</p>		<p style="text-align: center;">NA</p> <p>Photo #:</p>	<ul style="list-style-type: none"> • Change control height • •
<p>2.28 If there is a LULA elevator, are the in-car controls centered on a side wall?</p>	<p><input type="checkbox"/> Yes <input type="checkbox"/> No Measurement:</p>		<p style="text-align: center;">NA</p> <p>Photo #:</p>	<ul style="list-style-type: none"> • Reconfigure controls • •
<p>2.29 If there is a full size or LULA elevator:</p> <p>Are the car control buttons designated with raised characters? Are the car control buttons designated with Braille?</p>	<p><input type="checkbox"/> Yes <input type="checkbox"/> No</p> <p><input type="checkbox"/> Yes <input type="checkbox"/> No</p>		<p style="text-align: center;">NA</p> <p>Photo #:</p>	<ul style="list-style-type: none"> • Add raised characters • Add Braille •

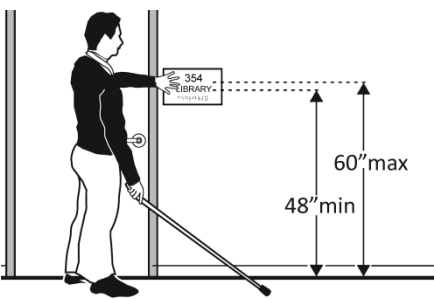
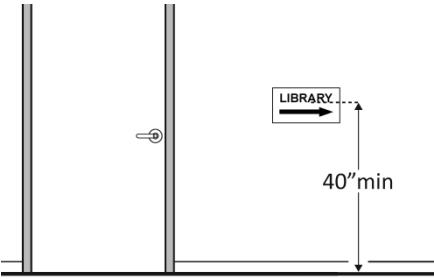
<p>2.30 If there is a full size or LULA elevator, are there audible signals which sound as the car passes or is about to stop at a floor?</p>	<p><input type="checkbox"/> Yes <input type="checkbox"/> No</p>		<p>Photo #: NA</p>	<ul style="list-style-type: none"> • Install audible signals • •
<p>2.31 If there is a full size or LULA elevator:</p> <p>Is there a sign on both door jambs at every floor identifying the floor?</p> <p>Is there a tactile star on both jambs at the main entry level?</p> <p>Do text characters contrast with their backgrounds?</p> <p>Are text characters raised?</p> <p>Is there Braille?</p> <p>Is the sign mounted between 48 inches to the baseline of the lowest character and 60 inches to the baseline of the highest character above the floor?*</p>	<p><input type="checkbox"/> Yes <input type="checkbox"/> No</p> <p><input type="checkbox"/> Yes <input type="checkbox"/> No</p> <p><input type="checkbox"/> Yes <input type="checkbox"/> No</p> <p><input type="checkbox"/> Yes <input type="checkbox"/> No</p> <p><input type="checkbox"/> Yes <input type="checkbox"/> No</p> <p><input type="checkbox"/> Yes <input type="checkbox"/> No</p> <p><input type="checkbox"/> Yes <input type="checkbox"/> No</p> <p>Measurement:</p>		<p>Photo #: NA</p>	<ul style="list-style-type: none"> • Install signs • Change sign height • • <p>* If constructed before 3/15/2012 and mounted no higher than 60 inches to the centerline of the sign, relocation is not required</p>
<p>Platform Lifts (2010 Standards – 410)</p>				

<p>2.32 If a lift is provided, can it be used without assistance from others?</p>	<p><input type="checkbox"/> Yes <input type="checkbox"/> No</p>		<p style="text-align: center;">NA</p> <p>Photo #:</p>	<ul style="list-style-type: none"> • Reconfigure so independently operable • •
<p>2.33 Is there a clear floor space at least 30 inches wide by at least 48 inches long for a person using a wheelchair to approach and reach the controls to use the lift?</p>	<p><input type="checkbox"/> Yes <input type="checkbox"/> No</p> <p>Measurement:</p>		<p style="text-align: center;">NA</p> <p>Photo #:</p>	<ul style="list-style-type: none"> • Remove obstructions • •
<p>2.34 Are the lift controls no less than 15 inches and no greater than 48 inches above the floor?</p>	<p><input type="checkbox"/> Yes <input type="checkbox"/> No</p> <p>Measurement:</p>		<p style="text-align: center;">NA</p> <p>Photo #:</p>	<ul style="list-style-type: none"> • Change control height • •
<p>2.35 Is there a clear floor space at least 30 inches wide by at least 48 inches long inside the lift?</p>	<p><input type="checkbox"/> Yes <input type="checkbox"/> No</p> <p>Measurement:</p>		<p style="text-align: center;">NA</p> <p>Photo #:</p>	<ul style="list-style-type: none"> • Replace lift • •

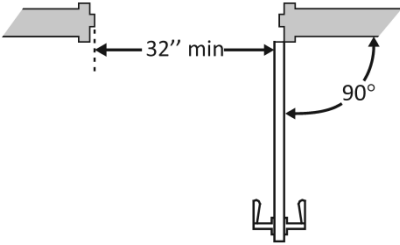
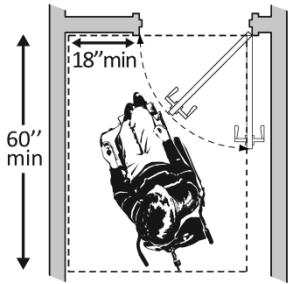
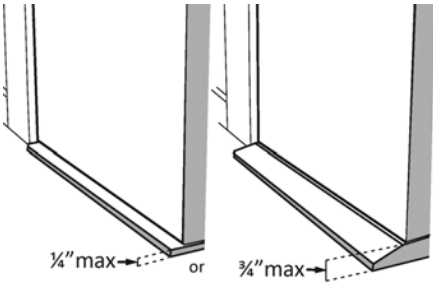
<p>2.36 If there is an end door, is the clear opening width at least 32 inches?</p>	<p><input type="checkbox"/> Yes <input type="checkbox"/> No</p> <p>Measurement:</p>		<p style="text-align: center; color: red; font-weight: bold;">NA</p> <p>Photo #:</p>	<ul style="list-style-type: none"> • Alter door width • •
<p>2.37 If there is a side door, is the clear opening width at least 42 inches?</p>	<p><input type="checkbox"/> Yes <input type="checkbox"/> No</p> <p>Measurement:</p>		<p style="text-align: center; color: red; font-weight: bold;">NA</p> <p>Photo #:</p>	<ul style="list-style-type: none"> • Alter door width • •

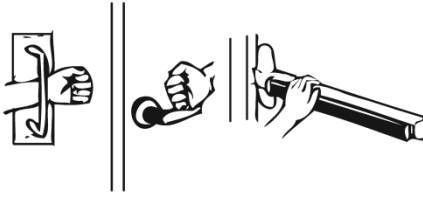
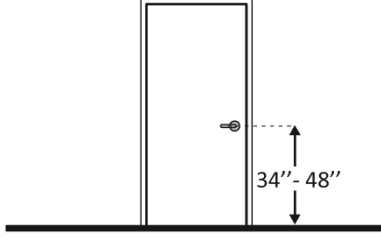
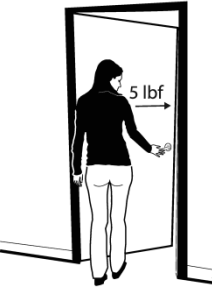
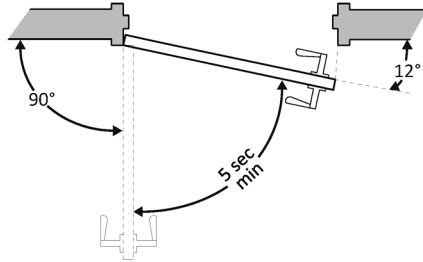
Signs (2010 Standards – 703) Note: “Tactile characters” are read using touch, i.e. raised characters and Braille.

<p>2.38 If there are signs designating permanent rooms and spaces not likely to change over time, e.g. room numbers and letters, room names, and exit signs:</p> <p>Do text characters contrast with their backgrounds?</p> <p>Are text characters raised?</p> <p>Is there Braille?</p> <p>Is the sign mounted: On the wall on the latch side of the door?</p>	<p><input checked="" type="checkbox"/> Yes <input type="checkbox"/> No</p> <p><input type="checkbox"/> Yes <input checked="" type="checkbox"/> No</p> <p><input type="checkbox"/> Yes <input checked="" type="checkbox"/> No</p> <p><input checked="" type="checkbox"/> Yes <input type="checkbox"/> No</p>		<p style="text-align: center; color: red; font-weight: bold;">NA</p> <p>Photo #:</p>	<ul style="list-style-type: none"> • Install tactile sign • Relocate sign •
---	---	---	--	--

<p>Note: Signs are permitted on the push side of doors with closers and without hold-open devices.</p> <p>With clear floor space beyond the arc of the door swing between the closed position and 45-degree open position, at least 18 x 18 inches centered on the tactile characters?*</p> <p>So the baseline of the lowest character is at least 48 inches above the floor and the baseline of the highest character is no more than 60 inches above the floor? *</p> <p>Note: If the sign is at double doors with one active leaf, the sign should be on the inactive leaf; if both leaves are active, the sign should be on the wall to the right of the right leaf.</p>	<p><input type="checkbox"/> Yes <input checked="" type="checkbox"/> No</p> <p>Measurement:</p> <p><input checked="" type="checkbox"/> Yes <input type="checkbox"/> No</p> <p>Measurement:</p>		<p>Photo #: 2.38</p>	<p>*If constructed before 3/15/2010 and a person may approach within 3 inches of the sign without encountering protruding objects or standing within the door swing, relocation not required</p> <p>*If constructed before 3/15/2012 and mounted no higher than 60 inches to the centerline of the sign, relocation not required</p>
<p>2.39 If there are signs that provide direction to or information about interior spaces:</p> <p>Do text characters contrast with their backgrounds?</p> <p>Is the sign mounted so that characters are at least 40 inches above the floor?</p>	<p><input checked="" type="checkbox"/> Yes <input type="checkbox"/> No</p> <p><input checked="" type="checkbox"/> Yes <input type="checkbox"/> No</p> <p>Measurement:</p>		<p>Photo #: 2.38</p>	<ul style="list-style-type: none"> • Install signs with contrasting characters • Change sign height • <p>Raised characters and Braille are not required</p>

Interior Doors – to classrooms, medical exam rooms, conference rooms, etc. (2010 Standards – 404)

<p>2.40 Is the door opening width at least 32 inches clear, between the face of the door and the stop, when the door is open 90 degrees?</p>	<p><input type="checkbox"/> Yes <input type="checkbox"/> No</p> <p>Measurement:</p>		<p style="text-align: center;">NA</p> <p>Photo #:</p>	<ul style="list-style-type: none"> • Install offset hinges • Alter the doorway •
<p>2.41 If there is a front approach to the pull side of the door, is there at least 18 inches of maneuvering clearance beyond the latch side plus at least 60 inches clear depth?</p> <p>On both sides of the door, is the floor surface of the maneuvering clearance level (no steeper than 1:48)?</p>	<p><input type="checkbox"/> Yes <input type="checkbox"/> No</p> <p>Measurement:</p> <p><input type="checkbox"/> Yes <input type="checkbox"/> No</p> <p>Measurement:</p>		<p style="text-align: center;">NA</p> <p>Photo #:</p>	<ul style="list-style-type: none"> • Remove obstructions • Reconfigure walls • Add automatic door opener <p>See 2010 Standards 404.2.4 for maneuvering clearance requirements on the push side of the door and side approaches to the pull side of the door</p>
<p>2.42 Is the door threshold edge no more than ¼ inch high?</p> <p>Or</p> <p>No more than ¾ inch high if slope is beveled no steeper than 1:2?</p> <p>Note: The first ¼ inch of the threshold may be vertical; the rest must be beveled.</p>	<p><input type="checkbox"/> Yes <input type="checkbox"/> No</p> <p>Measurement:</p> <p><input type="checkbox"/> Yes <input type="checkbox"/> No</p> <p>Measurement:</p>		<p style="text-align: center;">NA</p> <p>Photo #:</p>	<ul style="list-style-type: none"> • Remove or replace threshold • •

<p>2.43 Is the door equipped with hardware that is operable with one hand and does not require tight grasping, pinching and twisting of the wrist?</p>	<p><input type="checkbox"/> Yes <input type="checkbox"/> No</p>		<p style="text-align: center;">NA</p> <p>Photo #:</p>	<ul style="list-style-type: none"> • Replace inaccessible knob with lever, loop or push hardware • Add automatic door opener •
<p>2.44 Are the operable parts of the hardware no less than 34 inches and no greater than 48 inches above the floor?</p>	<p><input type="checkbox"/> Yes <input type="checkbox"/> No</p> <p>Measurement:</p>		<p style="text-align: center;">NA</p> <p>Photo #:</p>	<ul style="list-style-type: none"> • Change hardware height • •
<p>2.45 Can the door be opened easily (5 pounds maximum force)?</p> <p>Note: You can use a pressure gauge or fish scale to measure force. If you do not have a pressure gauge or fish scale you will need to judge whether the door is easy to open.</p>	<p><input type="checkbox"/> Yes <input type="checkbox"/> No</p> <p>Measurement:</p>		<p style="text-align: center;">NA</p> <p>Photo #:</p>	<ul style="list-style-type: none"> • Adjust or replace closers • Install lighter doors • Install power-assisted or automatic door openers
<p>2.46 If the door has a closer, does it take at least 5 seconds to close from an open position of 90 degrees to a position of 12 degrees from the latch?</p>	<p><input type="checkbox"/> Yes <input type="checkbox"/> No</p> <p>Measurement:</p>		<p style="text-align: center;">NA</p> <p>Photo #:</p>	<ul style="list-style-type: none"> • Adjust closer • •

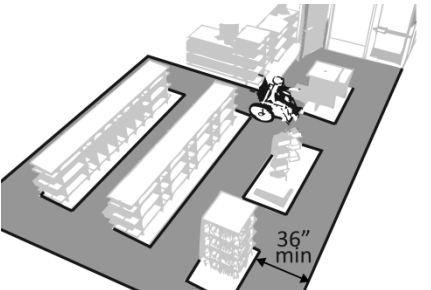

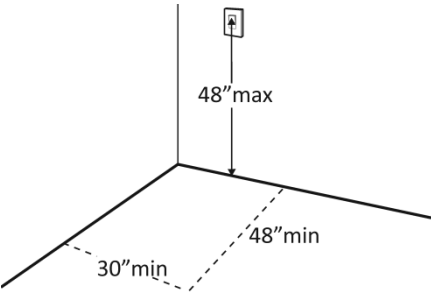
Rooms and Spaces – stores, supermarkets, libraries, etc. (2010 Standards – 302, 304, & 402)				
<p>2.47 Are aisles and pathways to goods and services, and to one of each type of sales and service counters, at least 36 inches wide?</p>	<p><input type="checkbox"/> Yes <input type="checkbox"/> No</p> <p>Measurement:</p>		<p style="text-align: center; color: red; font-weight: bold;">NA</p> <p>Photo #:</p>	<ul style="list-style-type: none"> • Rearrange goods, equipment and furniture • •
<p>2.48 Are floor surfaces stable, firm and slip resistant?</p>	<p><input type="checkbox"/> Yes <input type="checkbox"/> No</p>		<p>Photo #:</p>	<ul style="list-style-type: none"> • Change floor surface • •
<p>2.49 If there is carpet:</p> <p>Is it no higher than ½ inch?</p> <p>Is it securely attached along the edges?</p>	<p><input type="checkbox"/> Yes <input type="checkbox"/> No</p> <p>Measurement:</p> <p><input type="checkbox"/> Yes <input type="checkbox"/> No</p>		<p style="text-align: center; color: red; font-weight: bold;">NA</p> <p>Photo #:</p>	<ul style="list-style-type: none"> • Replace carpet • •
Controls – light switches, security and intercom systems, emergency/alarm boxes, etc. (2010 Standards – 309)				
<p>2.50 Is there a clear floor space at least 30 inches wide by at least 48 inches long for a forward or parallel approach?</p> <p>Are the operable parts no higher than 48 inches above the floor?*</p>	<p><input type="checkbox"/> Yes <input type="checkbox"/> No</p> <p>Measurement:</p> <p><input type="checkbox"/> Yes <input type="checkbox"/> No</p> <p>Measurement:</p>		<p style="text-align: center; color: red; font-weight: bold;">NA</p>	<ul style="list-style-type: none"> • Change height of control • • <p>*If constructed before 3/15/2012 and a parallel approach is provided, controls can be 54 inches above the floor</p>

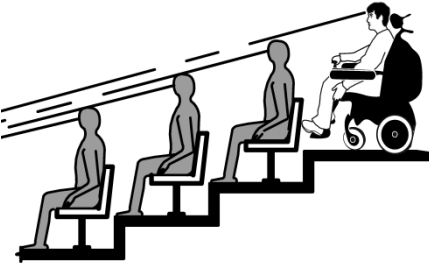
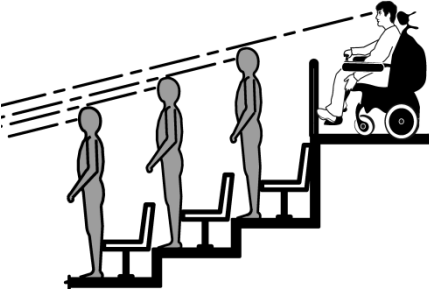

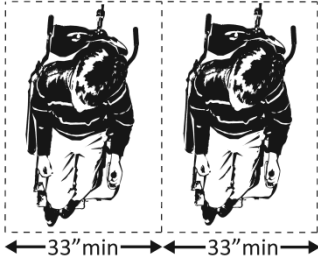
			Photo #:	
--	--	--	----------	--

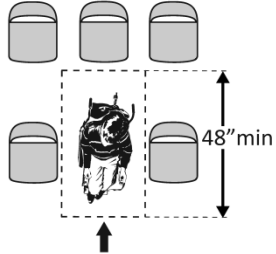
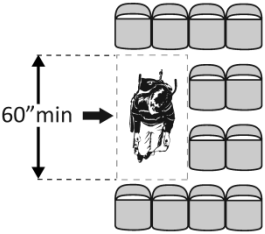
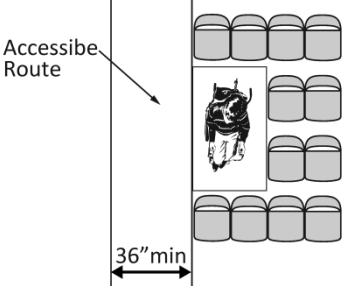
<p>2.51 Can the control be operated with one hand and without tight grasping, pinching, or twisting of the wrist?</p>	<input type="checkbox"/> Yes <input type="checkbox"/> No		<p>Photo #:</p> <p style="text-align: center;">NA</p>	<ul style="list-style-type: none"> • Replace control • •
--	--	--	--	---

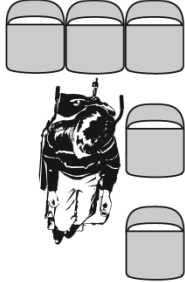

Seating: Assembly Areas – theaters, auditoriums, stadiums, theater style classrooms, etc. (2010 Standards – 221 & 802)


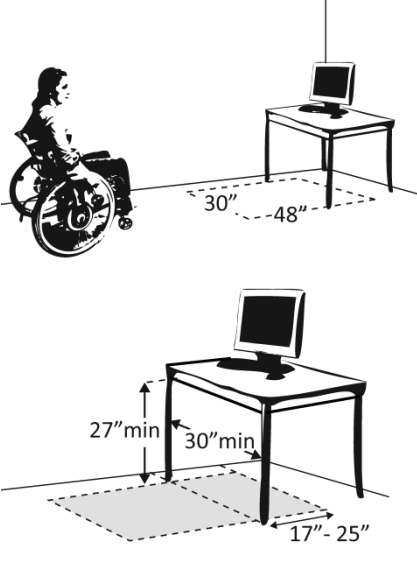
<p>2.52 Are an adequate number of wheelchair spaces provided?</p>	<input type="checkbox"/> Yes <input type="checkbox"/> No	<table border="1"> <thead> <tr> <th># of Seats</th> <th>Wheelchair Spaces</th> </tr> </thead> <tbody> <tr> <td>4 - 25</td> <td>1</td> </tr> <tr> <td>26 - 50</td> <td>2</td> </tr> <tr> <td>51 - 150</td> <td>4</td> </tr> <tr> <td>151 - 300</td> <td>5</td> </tr> <tr> <td colspan="2">300+ see 2010 Standards 221.2.1.</td> </tr> </tbody> </table>	# of Seats	Wheelchair Spaces	4 - 25	1	26 - 50	2	51 - 150	4	151 - 300	5	300+ see 2010 Standards 221.2.1.		<p>Photo #:</p> <p style="text-align: center;">NA</p>	<ul style="list-style-type: none"> • Reconfigure to add wheelchair spaces • •
# of Seats	Wheelchair Spaces															
4 - 25	1															
26 - 50	2															
51 - 150	4															
151 - 300	5															
300+ see 2010 Standards 221.2.1.																

<p>2.53 Are wheelchair spaces dispersed to allow location choices and viewing angles equivalent to other seating, including specialty seating areas that provide distinct services and amenities?</p>	<input type="checkbox"/> Yes <input type="checkbox"/> No		<p>Photo #:</p> <p style="text-align: center;">NA</p>	<ul style="list-style-type: none"> • Reconfigure to disperse wheelchair spaces • •
--	--	--	--	---

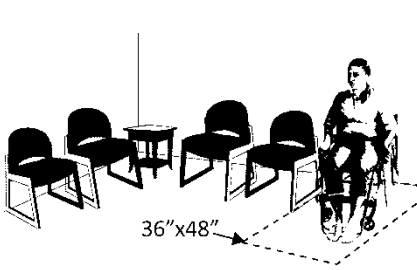
<p>2.54 Where people are expected to remain seated, do people in wheelchair spaces have a clear line of sight over and between the heads of others in front of them?</p>	<p><input type="checkbox"/> Yes <input type="checkbox"/> No</p>		<p style="text-align: center;">NA</p> <p>Photo #:</p>	<ul style="list-style-type: none"> • Alter for line of sight • •
<p>2.55 Where people are expected to stand, do people in wheelchair spaces have a clear line of sight over and between the heads of others in front of them?</p>	<p><input type="checkbox"/> Yes <input type="checkbox"/> No</p>		<p style="text-align: center;">NA</p> <p>Photo #:</p>	<ul style="list-style-type: none"> • Alter for line of sight • •
<p>2.56 If there is a single wheelchair space, is it at least 36 inches wide?</p>	<p><input type="checkbox"/> Yes <input type="checkbox"/> No</p> <p>Measurement:</p>		<p style="text-align: center;">NA</p> <p>Photo #:</p>	<ul style="list-style-type: none"> • Alter space • •
<p>2.57 If there are two adjacent wheelchair spaces, are they each at least 33 inches wide?</p>	<p><input type="checkbox"/> Yes <input type="checkbox"/> No</p> <p>Measurement:</p>		<p style="text-align: center;">NA</p> <p>Photo #:</p>	<ul style="list-style-type: none"> • Alter spaces • •

<p>2.58 If the wheelchair space can be entered from the front or rear, is it at least 48 inches deep?</p>	<p><input type="checkbox"/> Yes <input type="checkbox"/> No</p> <p>Measurement:</p>		<p style="text-align: center;">NA</p> <p>Photo #:</p>	<ul style="list-style-type: none"> • Alter space • •
<p>2.59 If the wheelchair space can only be entered from the side, is it at least 60 inches deep?</p>	<p><input type="checkbox"/> Yes <input type="checkbox"/> No</p> <p>Measurement:</p>		<p style="text-align: center;">NA</p> <p>Photo #:</p>	<ul style="list-style-type: none"> • Alter space • •
<p>2.60 Do wheelchair spaces adjoin, but not overlap, accessible routes?</p>	<p><input type="checkbox"/> Yes <input type="checkbox"/> No</p>		<p style="text-align: center;">NA</p> <p>Photo #:</p>	<ul style="list-style-type: none"> • Alter spaces • •
<p>2.61 Is there at least one companion seat for each wheelchair space?</p>	<p><input type="checkbox"/> Yes <input type="checkbox"/> No</p>		<p style="text-align: center;">NA</p> <p>Photo #:</p>	<ul style="list-style-type: none"> • Add companion seats • •

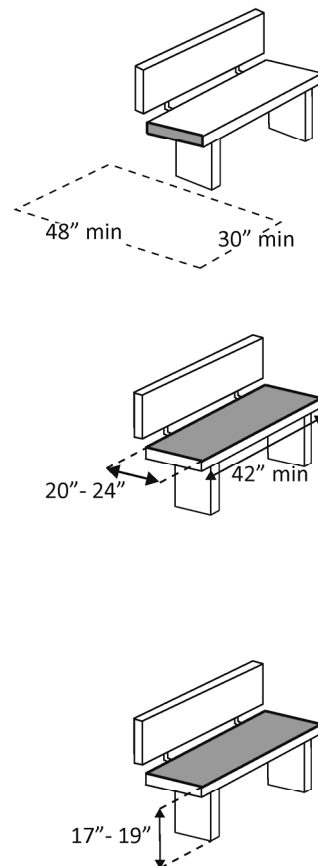
<p>2.62 Is the companion seat located so the companion is shoulder-to-shoulder with the person in a wheelchair?</p>	<p><input type="checkbox"/> Yes <input type="checkbox"/> No</p>		<p style="text-align: center;">NA</p> <p>Photo #:</p>	<ul style="list-style-type: none"> • Alter seating • •
<p>2.63 Is the companion seat equivalent in size, quality, comfort and amenities to seating in the immediate area?</p>	<p><input type="checkbox"/> Yes <input type="checkbox"/> No</p>		<p style="text-align: center;">NA</p> <p>Photo #:</p>	<ul style="list-style-type: none"> • Add equivalent seating • •
<p>Seating: At dining surfaces (restaurants, cafeterias, bars, etc.) and non-employee work surfaces (libraries, conference rooms, etc.) (2010 Standards – 226 & 902)</p>				
<p>2.64 Are at least 5%, but no fewer than one, of seating and standing spaces accessible for people who use wheelchairs?</p>	<p><input type="checkbox"/> Yes <input type="checkbox"/> No</p> <p>Total #:</p> <p>Wheelchair #:</p>		<p style="text-align: center;">NA</p> <p>Photo #:</p>	<ul style="list-style-type: none"> • Alter to provide accessible spaces • •
<p>2.65 Is there a route at least 36 inches wide to accessible seating?</p>	<p><input type="checkbox"/> Yes <input type="checkbox"/> No</p> <p>Measurement:</p>		<p style="text-align: center;">NA</p> <p>Photo #:</p>	<ul style="list-style-type: none"> • Widen route • •

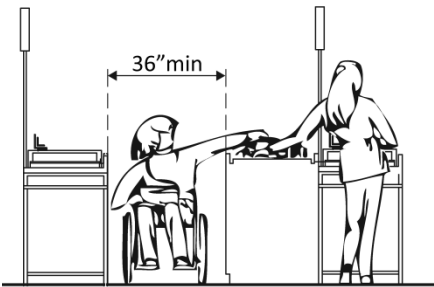
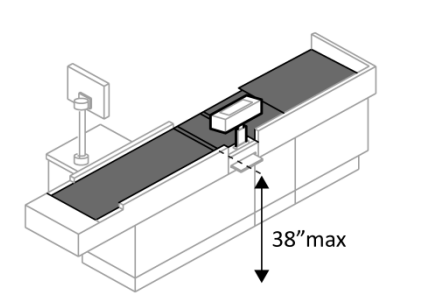
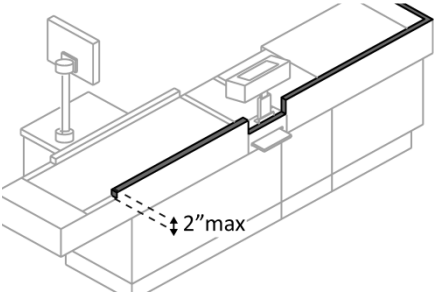
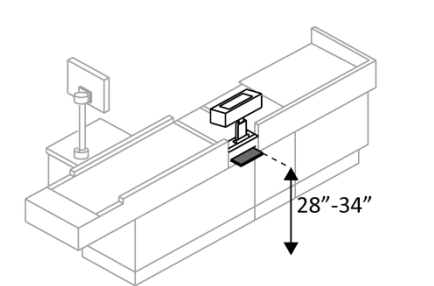
<p>2.66 At the accessible space(s), is the top of the accessible surface no less than 28 inches and no greater than 34 inches above the floor?</p>	<p><input type="checkbox"/> Yes <input type="checkbox"/> No</p> <p>Measurement:</p>		<p style="text-align: center;">NA</p> <p>Photo #:</p>	<ul style="list-style-type: none"> • Alter surface height • •
<p>2.67 Is there a clear floor space at least 30 inches wide by at least 48 inches long for a forward approach?</p> <p>Does it extend no less than 17 inches and no greater than 25 inches under the surface?</p> <p>Is there knee space at least 27 inches high and at least 30 inches wide?</p>	<p><input type="checkbox"/> Yes <input type="checkbox"/> No</p> <p>Measurement:</p> <p><input type="checkbox"/> Yes <input type="checkbox"/> No</p> <p>Measurement:</p> <p><input type="checkbox"/> Yes <input type="checkbox"/> No</p> <p>Measurement:</p>		<p style="text-align: center;">NA</p> <p>Photo #:</p>	<ul style="list-style-type: none"> • Alter table or work surface • Add accessible table or work surface •


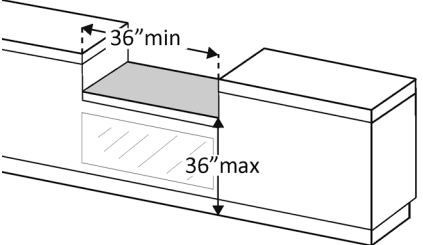
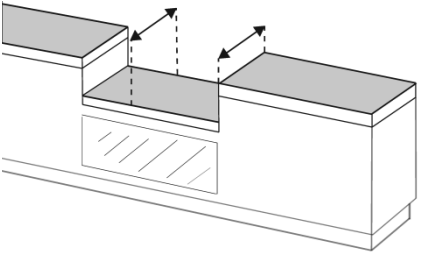
Seating: General – reception areas, waiting rooms, etc. (2010 Standards – 801)

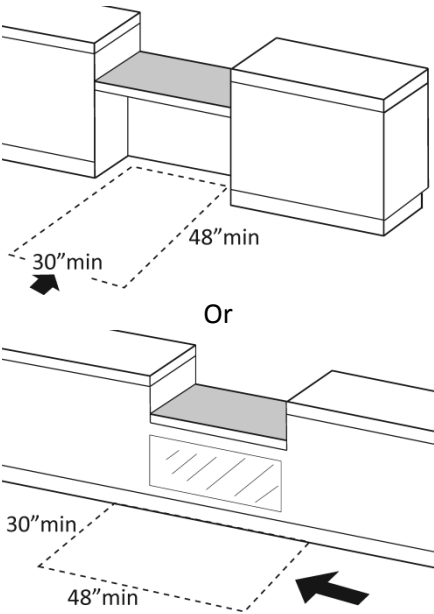
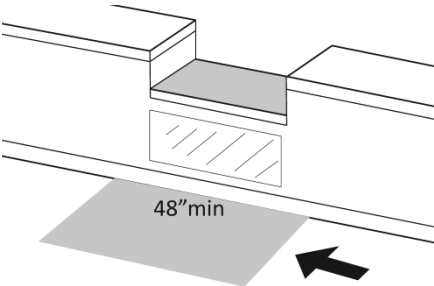
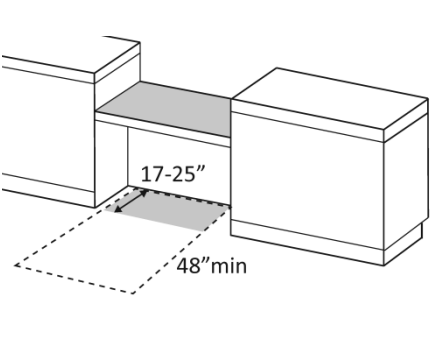
<p>2.68 Is there at least one space at least 36 inches wide by at least 48 inches long for a person in a wheelchair?</p>	<p><input checked="" type="checkbox"/> Yes <input type="checkbox"/> No</p> <p>Measurement:</p> <p style="color: red;">36" X 48"</p>		<p>Photo #: 2.68</p>	<ul style="list-style-type: none"> • Move furniture and equipment to provide space • •
---	--	--	-----------------------------	---

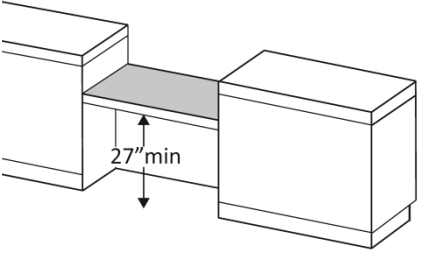
Benches – In locker rooms, dressing rooms, fitting rooms (2010 Standards – 803 & 903)

<p>2.69 In locker rooms, dressing rooms and fitting rooms, is there at least one room with a bench?</p>	<p><input type="checkbox"/> Yes <input type="checkbox"/> No</p>		<p style="text-align: center;">NA</p> <p>Photo #:</p>	<ul style="list-style-type: none"> • Add bench • •
<p>2.70 Is there a clear floor space at least 30 inches wide by at least 48 inches long at the end of the bench and parallel to the short axis of the bench?</p> <p>Is the bench seat at least 42 inches long and no less than 20 inches and no greater than 24 inches deep?</p> <p>Does the bench have back support or is it affixed to a wall?</p> <p>Is the top of the bench seat no less than 17 inches and no greater than 19 inches above the floor?</p>	<p><input type="checkbox"/> Yes <input type="checkbox"/> No Measurement:</p> <p><input type="checkbox"/> Yes <input type="checkbox"/> No Measurement:</p> <p><input type="checkbox"/> Yes <input type="checkbox"/> No</p> <p><input type="checkbox"/> Yes <input type="checkbox"/> No Measurement:</p>		<p style="text-align: center;">NA</p> <p>Photo #:</p>	<ul style="list-style-type: none"> • Move bench • Replace bench • Affix bench to wall • •

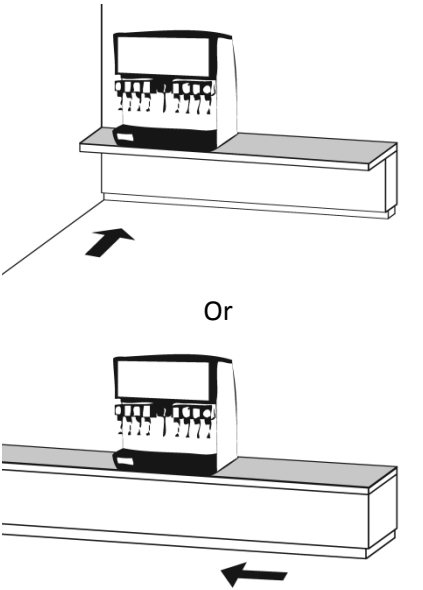
Check-Out Aisles – supermarkets, large retail stores, etc. (2010 Standards – 904)				
<p>2.71 Is the aisle at least 36 inches wide?</p>	<p><input type="checkbox"/> Yes <input type="checkbox"/> No</p> <p>Measurement:</p>		<p>Photo #:</p> <p style="text-align: center;">NA</p>	<ul style="list-style-type: none"> • Widen aisle • •
<p>2.72 Is the counter surface of at least one aisle no higher than 38 inches above the floor?</p>	<p><input type="checkbox"/> Yes <input type="checkbox"/> No</p> <p>Measurement:</p>		<p>Photo #:</p> <p style="text-align: center;">NA</p>	<ul style="list-style-type: none"> • Lower counter • •
<p>2.73 Is the top of the counter edge protection no higher than 2 inches above the counter surface?</p>	<p><input type="checkbox"/> Yes <input type="checkbox"/> No</p> <p>Measurement:</p>		<p>Photo #:</p> <p style="text-align: center;">NA</p>	<ul style="list-style-type: none"> • Lower edge protection • •
<p>2.74 If there is a check writing surface, is the top no less than 28 inches and no greater than 34 inches above the floor?</p>	<p><input type="checkbox"/> Yes <input type="checkbox"/> No</p> <p>Measurement:</p>		<p>Photo #:</p> <p style="text-align: center;">NA</p>	<ul style="list-style-type: none"> • Alter check writing surface • •

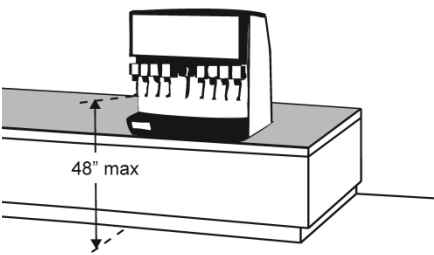
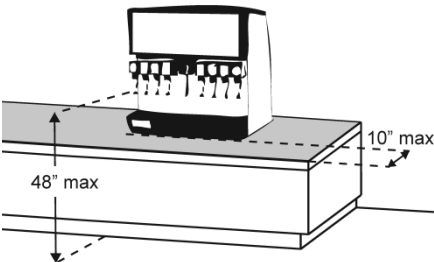
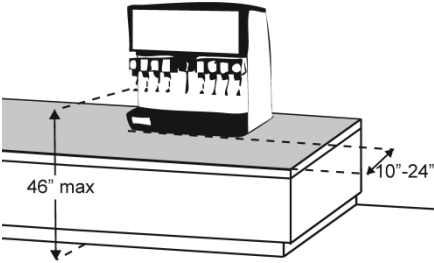
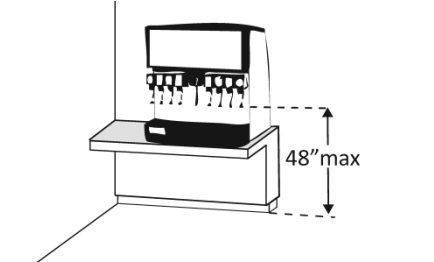
<p>2.75 If there is more than one check-out aisle is there a sign with the International Symbol of Accessibility at the accessible aisle?</p>	<p><input type="checkbox"/> Yes <input type="checkbox"/> No</p>		<p style="text-align: center;">NA</p> <p>Photo #:</p>	<ul style="list-style-type: none"> • Add sign • •
<p>Sales & Service Counters – banks, stores, dry cleaners, auto repair shops, fitness clubs, etc. (2010 Standards – 904)</p>				
<p>2.76 Is there a portion of at least one of each type of counter that is: No higher than 36 inches above the floor? At least 36 inches long?</p>	<p><input type="checkbox"/> Yes <input type="checkbox"/> No Measurement: <input type="checkbox"/> Yes <input type="checkbox"/> No Measurement:</p>		<p style="text-align: center;">NA</p> <p>Photo #:</p>	<ul style="list-style-type: none"> • Lower section of counter • Lengthen section of counter •
<p>2.77 Does the accessible portion of the counter extend the same depth as the counter top?</p>	<p><input type="checkbox"/> Yes <input type="checkbox"/> No Measurement:</p>		<p style="text-align: center;">NA</p> <p>Photo #:</p>	<ul style="list-style-type: none"> • Alter accessible portion • •

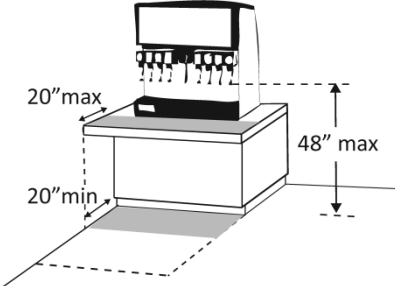
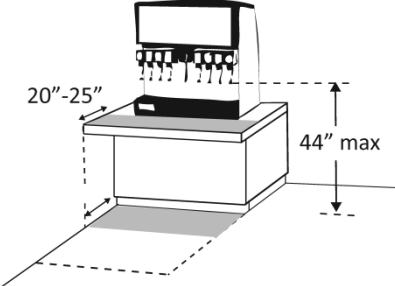
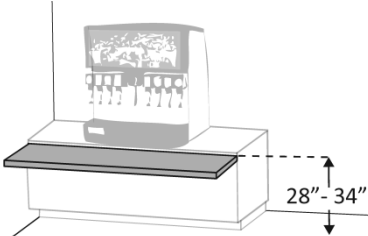
<p>2.78 Is there a clear floor space at least 30 inches wide by at least 48 inches long for a forward or parallel approach?</p>	<p><input type="checkbox"/> Yes <input type="checkbox"/> No</p> <p><input type="checkbox"/> Parallel Measurement:</p> <p><input type="checkbox"/> Forward Measurement:</p>		<p style="text-align: center; color: red; font-weight: bold;">NA</p> <p>Photo #:</p>	<ul style="list-style-type: none"> • Reconfigure to provide a parallel or forward approach • •
<p>2.79 For a parallel approach, is the clear floor space positioned with the 48 inches adjacent to the accessible length of counter?</p>	<p><input type="checkbox"/> Yes <input type="checkbox"/> No</p> <p>Measurement:</p>		<p style="text-align: center; color: red; font-weight: bold;">NA</p> <p>Photo #:</p>	<ul style="list-style-type: none"> • If a parallel approach is not possible, a forward approach is required • •
<p>2.80 For a forward approach:</p> <p>Do no less than 17 and no greater than 25 inches of the clear floor space extend under the accessible length of the counter?</p> <p>Is there at least 27 inches clearance from the floor to the</p>	<p><input type="checkbox"/> Yes <input type="checkbox"/> No</p> <p>Measurement:</p> <p><input type="checkbox"/> Yes <input type="checkbox"/> No</p>		<p style="text-align: center; color: red; font-weight: bold;">NA</p> <p>Photo #:</p>	<ul style="list-style-type: none"> • Reconfigure to provide knee clearance • •

<p>bottom of the counter?</p>	<p>Measurement:</p>		<p>Photo #:</p>	
-------------------------------	---------------------	--	-----------------	--

Food Service Lines – in cafeterias, salad bars, eat-in fast food establishments, etc. (2010 Standards – 904)

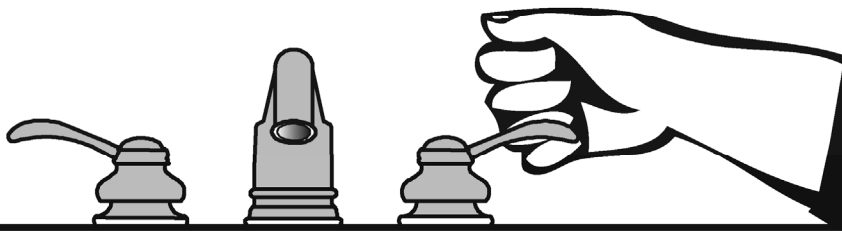
<p>2.81 Does at least one of each type of self-service shelf or dispensing device for tableware, dishware, condiments, food and beverages have a forward or parallel approach?</p>	<p><input type="checkbox"/> Yes <input type="checkbox"/> No</p> <p><input type="checkbox"/> Forward</p> <p><input type="checkbox"/> Parallel</p>		<p style="color: red; text-align: center;">NA</p> <p>Photo #:</p>	<ul style="list-style-type: none"> • Reconfigure to provide approach • •
---	--	---	---	---

<p>2.82 If there is an unobstructed parallel approach, is the shelf or dispensing device no higher than 48 inches above the floor?</p>	<p><input type="checkbox"/> Yes <input type="checkbox"/> No</p> <p>Measurement:</p>		<p>Photo #:</p> <p style="text-align: center;">NA</p>	<ul style="list-style-type: none"> • Lower shelf and/or dispensing device • •
<p>2.83 If there is a shallow obstruction no deeper than 10 inches with a parallel approach, is the shelf or dispensing device no higher than 48 inches above the floor?</p>	<p><input type="checkbox"/> Yes <input type="checkbox"/> No</p> <p>Measurement:</p>		<p>Photo #:</p> <p style="text-align: center;">NA</p>	<ul style="list-style-type: none"> • Lower shelf and/or dispensing device • •
<p>2.84 If there is an obstruction no less than 10 inches and no greater than 24 inches deep with a parallel approach, is the shelf or dispensing device no higher than 46 inches above the floor?</p>	<p><input type="checkbox"/> Yes <input type="checkbox"/> No</p> <p>Measurement:</p>		<p>Photo #:</p> <p style="text-align: center;">NA</p>	<ul style="list-style-type: none"> • Lower shelf and/or dispensing device • •
<p>2.85 If there is an unobstructed forward approach, is the shelf or dispensing device no higher than 48 inches above the floor?</p>	<p><input type="checkbox"/> Yes <input type="checkbox"/> No</p> <p>Measurement:</p>		<p>Photo #:</p> <p style="text-align: center;">NA</p>	<ul style="list-style-type: none"> • Lower shelf and/or dispensing device • •

<p>2.86 If there is an obstruction no deeper than 20 inches with a forward approach:</p> <p>Does clear floor space extend under the obstruction that is at least the same depth as the obstruction?</p> <p>Is the shelf or dispensing device no higher than 48 inches above the floor?</p>	<p><input type="checkbox"/> Yes <input type="checkbox"/> No Measurement:</p> <p><input type="checkbox"/> Yes <input type="checkbox"/> No Measurement:</p>		<p style="text-align: center; color: red; font-weight: bold;">NA</p> <p>Photo #:</p>	<ul style="list-style-type: none"> • Reconfigure to provide knee space • Lower shelf and/or dispensing device •
<p>2.87 If the obstruction is no less than 20 inches and no greater than 25 inches deep with a forward approach:</p> <p>Does clear floor space extend under the obstruction that is at least the same depth as the obstruction?</p> <p>Is the shelf or dispensing device no higher than 44 inches above the floor?</p>	<p><input type="checkbox"/> Yes <input type="checkbox"/> No Measurement:</p> <p><input type="checkbox"/> Yes <input type="checkbox"/> No Measurement:</p>		<p style="text-align: center; color: red; font-weight: bold;">NA</p> <p>Photo #:</p>	<ul style="list-style-type: none"> • Reconfigure to provide knee space • Lower shelf and/or dispensing device •
<p>2.88 If there is a tray slide, is the top no less than 28 inches and no greater than 34 inches above the floor?</p>	<p><input type="checkbox"/> Yes <input type="checkbox"/> No Measurement:</p>		<p style="text-align: center; color: red; font-weight: bold;">NA</p> <p>Photo #:</p>	<ul style="list-style-type: none"> • Reconfigure • •

The ADA Checklist for Readily Achievable Barrier Removal

Priority 3 – Men's Toilet Rooms



Project **SDDOT Rest Area Improvements**
FHU Reference Number 13-039-01
TSP Project Number 03120855

Building **HIDEWOOD NORTH**

Location **29N., MRM 160**

Date **09-17-2013 (Inspection)**

Surveyors **Timothy Roach, AIA**
Todd Schultz, PE

Robert King, CPD

Contact Information **TSP – (605) 343-6102**

When toilet rooms are open to the public they should be accessible to people with disabilities.





Institute for Human Centered Design
www.HumanCenteredDesign.org

November 2011



ADA National Network
Questions on the ADA 800-949-4232 voice/tty
www.ADAchecklist.org

Priority 3 – Toilet Rooms		Comments	Possible Solutions
<p>3.1 If toilet rooms are available to the public, is at least one toilet room accessible? (Either one for each sex, or one unisex.)</p>	<input checked="" type="checkbox"/> Yes <input type="checkbox"/> No	<p>Photo #: 3.5</p>	<ul style="list-style-type: none"> • Reconfigure toilet rooms • Combine toilet rooms to create one unisex accessible toilet room •
<p>3.2 Are there signs at inaccessible toilet rooms that give directions to accessible toilet rooms?</p>	<input type="checkbox"/> Yes <input type="checkbox"/> No	 <p>Photo #:</p>	<p>NA</p> <ul style="list-style-type: none"> • Install signs • •
<p>3.3 If not all toilet rooms are accessible, is there a sign at the accessible toilet room with the International Symbol of Accessibility?</p>	<input type="checkbox"/> Yes <input type="checkbox"/> No	 <p>Photo #:</p>	<p>NA</p> <ul style="list-style-type: none"> • Install sign • •
<p>Accessible Route (2010 Standards – Chapter 4)</p>			
<p>3.4 Is there a route to the accessible toilet room(s) that does not include the use of stairs?</p> <p>Is the route accessible? (See Priority 2 Interior Accessible Route for specifics.)</p>	<input checked="" type="checkbox"/> Yes <input type="checkbox"/> No <input checked="" type="checkbox"/> Yes <input type="checkbox"/> No	<p>Route to restroom doors is accessible from lobby, restroom doors are not accessible. Photo #: 3.4</p>	<ul style="list-style-type: none"> • Alter route • •

Signs at Toilet Rooms (2010 Standards – 703)

3.5 Do text characters contrast with their backgrounds?

Yes No

Are text characters raised?

Yes No

Is there Braille?

Yes No

Is the sign mounted:
On the wall on the latch side of the door?

Yes No

Note:

Signs are permitted on the push side of doors with closers and without hold-open devices.

With clear floor space beyond the arc of the door swing and 45-degree open position, at least 18 x 18 inches centered on the tactile characters? *

Yes No

Measurement:

NA

So the baseline of the lowest character is at least 48 inches above the floor and the baseline of the highest character is no more than 60 inches above the floor? *

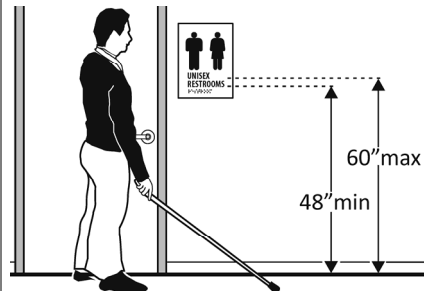
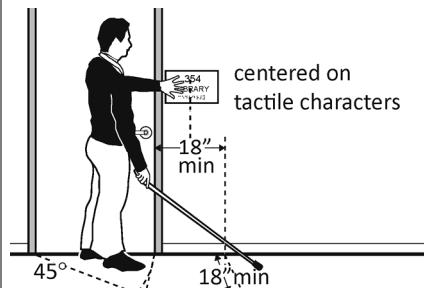
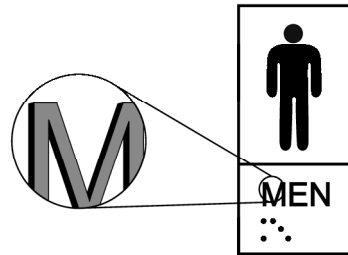
Yes No

Measurement:

NA

Note:

If the sign is at double doors with one active leaf, the sign should be on the inactive leaf; if both leaves are active, the sign



- Install tactile sign
- Relocate sign
-

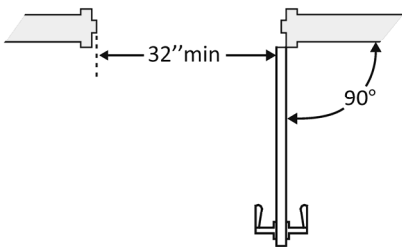
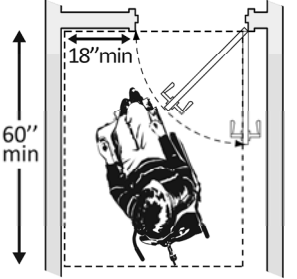
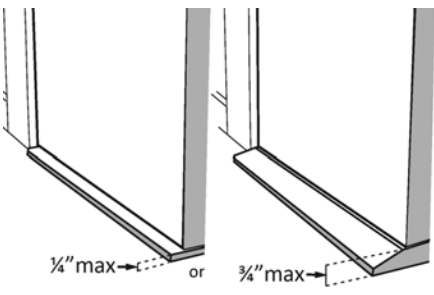
*If constructed before 3/15/2010 and a person may approach within 3 inches of the sign without encountering protruding objects or standing within the door swing, relocation not required

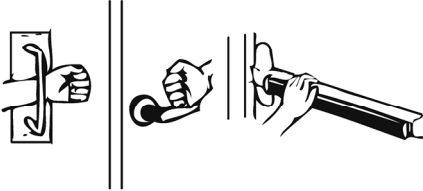
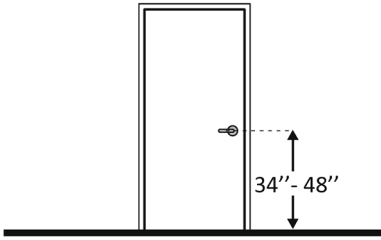

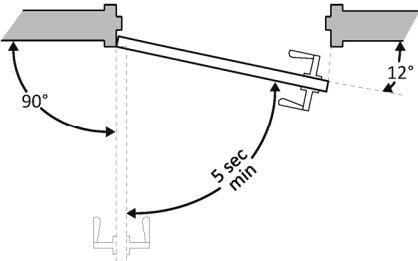
*If constructed before 3/15/2012 and mounted no higher than 60 inches to the centerline of the sign, relocation is not required

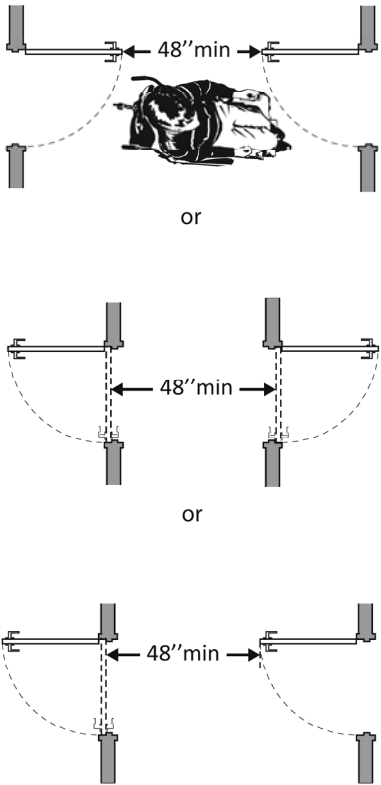
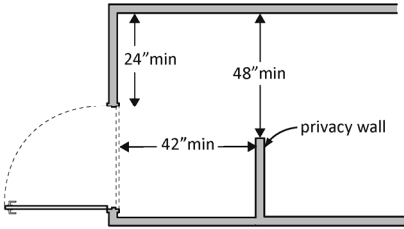
Photo #: **3.7**

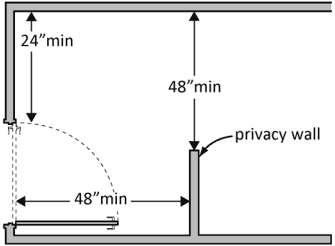

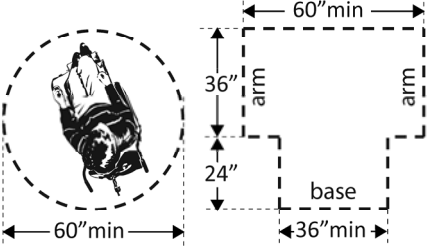
should be on the wall to the right of the right leaf.

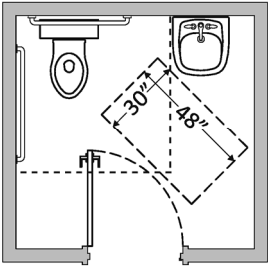
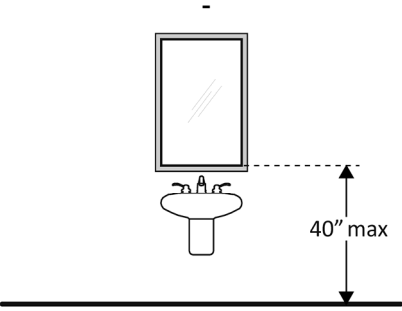
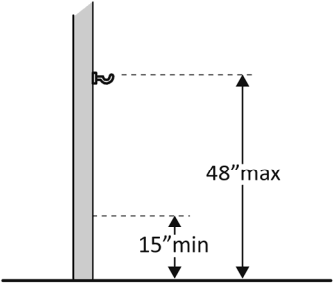
Entrance (2010 Standards – 404)

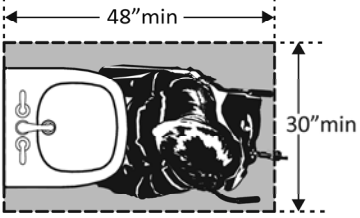
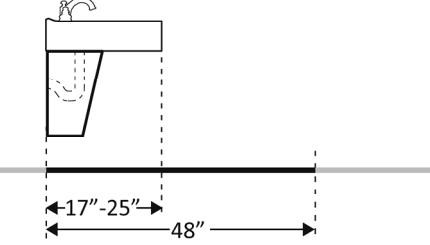
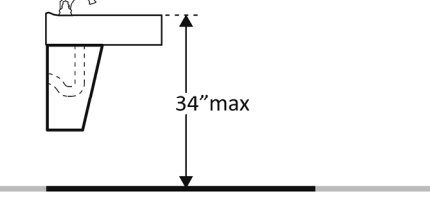
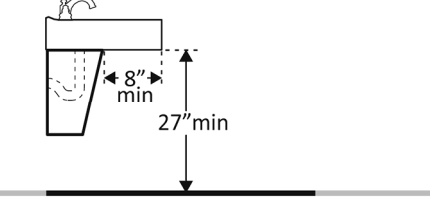
<p>3.6 Is the door opening width at least 32 inches clear, between the face of the door and the stop, when the door is open 90 degrees?</p>	<p><input checked="" type="checkbox"/> Yes <input type="checkbox"/> No</p> <p>Measurement:</p> <p>32"</p>		<p>Photo #: 3.6</p>	<ul style="list-style-type: none"> • Install offset hinges • Alter the doorway •
<p>3.7 If there is a front approach to the pull side of the door is there at least 18 inches of maneuvering clearance beyond the latch side plus 60 inches clear depth?</p> <p>On both sides of the door, is the floor surface of the maneuvering clearance level (no steeper than 1:48)?</p>	<p><input type="checkbox"/> Yes <input checked="" type="checkbox"/> No</p> <p>Measurement:</p> <p>6"</p> <p><input checked="" type="checkbox"/> Yes <input type="checkbox"/> No</p> <p>Measurement:</p>		<p>Photo #: 3.7</p>	<ul style="list-style-type: none"> • Remove obstructions • Reconfigure walls • Add automatic door opener <p>See 2010 Standards 404.2.4 for maneuvering clearance requirements on the push side of the door and side approaches to the pull side of the door</p>
<p>3.8 Is the door threshold edge no more than ¼ inch high?</p> <p>Or</p> <p>No more than ¾ inch high if slope is beveled no steeper than 1:2?</p> <p>Note: The first ¼ inch of the threshold may be vertical; the rest must be beveled.</p>	<p>Yes No</p> <p>Measurement:</p> <p><input type="checkbox"/> Yes <input type="checkbox"/> No</p> <p>Measurement:</p>		<p>NA</p> <p>Photo #:</p>	<ul style="list-style-type: none"> • Remove or replace threshold • •

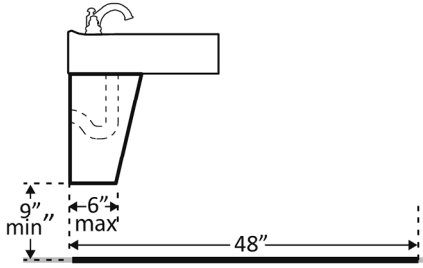
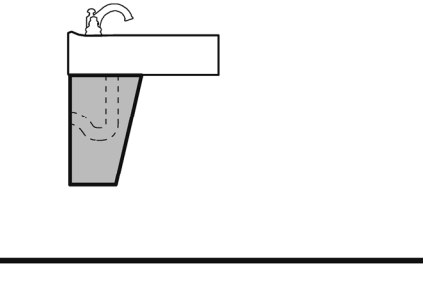
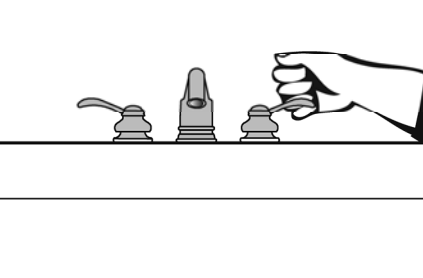
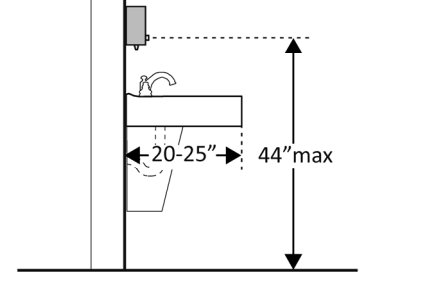
<p>3.9 Is the door equipped with hardware that is operable with one hand and does not require tight grasping, pinching, or twisting of the wrist? Check door handle and lock (if provided).</p>	<p><input checked="" type="checkbox"/> Yes <input type="checkbox"/> No</p> <p>Measurement:</p>		<p>Photo #: 3.9</p>	<ul style="list-style-type: none"> • Replace knobs or latches with lever or loop handles • Install power-assisted or automatic door openers •
<p>3.10 Are the operable parts of the door hardware mounted no less than 34 inches and no greater than 48 inches above the floor?</p>	<p><input type="checkbox"/> Yes <input checked="" type="checkbox"/> No</p> <p>Measurement: 32" BOTTOM 48" TOP</p>		<p>Photo #: 3.10</p>	<ul style="list-style-type: none"> • Change hardware height • •
<p>3.11 Can the door be opened easily (5 pounds maximum force)?</p>	<p><input type="checkbox"/> Yes <input checked="" type="checkbox"/> No</p> <p>Measurement: 7 LB</p>		<p>Photo #: 3.9</p>	<ul style="list-style-type: none"> • Adjust or replace closers • Install lighter doors • Install power-assisted or automatic door openers
<p>3.12 If the door has a closer, does it take at least 5 seconds to close from an open position of 90 degrees to a position of 12 degrees from the latch?</p>	<p><input type="checkbox"/> Yes <input checked="" type="checkbox"/> No</p> <p>Measurement: 3 SEC.</p>		<p>Photo #: 3.9</p>	<ul style="list-style-type: none"> • Adjust closer • •

<p>3.13 If there are two doors in a series, e.g. vestibule, is the distance between the doors at least 48 inches plus the width of the doors when swinging into the space?</p>	<p><input type="checkbox"/> Yes <input type="checkbox"/> No</p> <p>Measurement:</p>		<p style="text-align: center; color: red; font-weight: bold;">NA</p> <p>Photo #:</p>	<ul style="list-style-type: none"> • Remove inner door • Change door swing •
<p>3.14 If there is a privacy wall and the door swings out, is there at least 24 inches of maneuvering clearance beyond the door latch side and 42 inches to the privacy wall?</p>	<p><input type="checkbox"/> Yes <input type="checkbox"/> No</p> <p>Measurement:</p>		<p style="text-align: center; color: red; font-weight: bold;">NA</p> <p>Photo #:</p>	<ul style="list-style-type: none"> • Reconfigure space • •

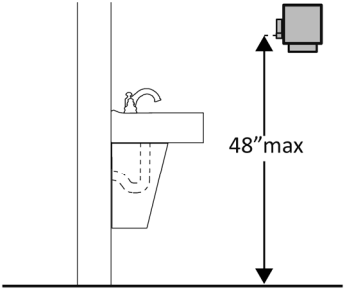
<p>3.15 If there is a privacy wall and the door swings in, is there at least 24 inches of maneuvering clearance beyond the door latch side and at least 48 inches to the privacy wall if there is no door closer or at least 54 inches if there is a door closer?</p>	<p><input type="checkbox"/> Yes <input type="checkbox"/> No</p> <p>Measurement:</p>		<p style="text-align: center; color: red; font-weight: bold;">NA</p> <p>Photo #:</p>	<ul style="list-style-type: none"> • Reconfigure space • •
In the Toilet Room				
<p>3.16 Is there a clear path to at least one of each type of fixture, e.g. lavatory, hand dryer, etc., that is at least 36 inches wide?</p>	<p><input checked="" type="checkbox"/> Yes <input type="checkbox"/> No</p> <p>Measurement:</p> <p style="color: red; font-weight: bold; text-align: center;">44"</p>		<p>Photo #: 3.17</p>	<ul style="list-style-type: none"> • Remove obstructions • •
<p>3.17 Is there clear floor space available for a person in a wheelchair to turn around, i.e. a circle at least 60 inches in diameter or a T-shaped space within a 60-inch square?*</p>	<p><input checked="" type="checkbox"/> Yes <input type="checkbox"/> No</p> <p>Measurement:</p> <p style="color: red; font-weight: bold; text-align: center;">86" x 106"</p>		<p>Photo #: 3.17</p>	<p>*The door to the toilet room may swing into the required turning space</p> <ul style="list-style-type: none"> • Move or remove partitions, fixtures or objects such as trash cans • •

<p>3.18 In a single user toilet room if the door swings in and over a clear floor space at an accessible fixture, is there a clear floor space at least 30 x 48 inches beyond the swing of the door?</p>	<p><input type="checkbox"/> Yes <input type="checkbox"/> No</p> <p>Measurement:</p>		<p style="text-align: center;">NA</p> <p>Photo #:</p>	<ul style="list-style-type: none"> • Reverse door swing • Alter toilet room •
<p>3.19 If the mirror is over a lavatory or countertop, is the bottom edge of the reflecting surface no higher than 40 inches above the floor? Or If the mirror is not over the lavatory or countertop, is the bottom edge of the reflecting surface no higher than 35 inches above the floor?*</p>	<p><input checked="" type="checkbox"/> Yes <input type="checkbox"/> No</p> <p>Measurement:</p> <p style="text-align: center;">39"</p> <p><input type="checkbox"/> Yes <input type="checkbox"/> No</p> <p>Measurement:</p> <p style="text-align: center;">NA</p>		<p>Photo #: 3.19</p>	<p>* If installed before 3/15/2012 and the bottom edge of the reflecting surface is no higher than 40 inches above the floor, lowering the mirror to 35 inches is not required</p> <ul style="list-style-type: none"> • Lower the mirror • Add another mirror •
<p>3.20 If there is a coat hook, is it no less than 15 inches and no greater than 48 inches above the floor?</p>	<p><input checked="" type="checkbox"/> Yes <input type="checkbox"/> No</p> <p>Measurement:</p> <p style="text-align: center;">46"</p>		<p>Photo #: 3.20</p>	<ul style="list-style-type: none"> • Adjust hook • Replace with or provide additional accessible hook •

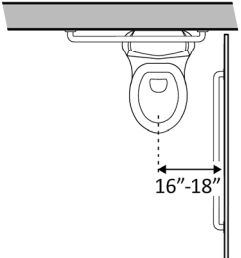
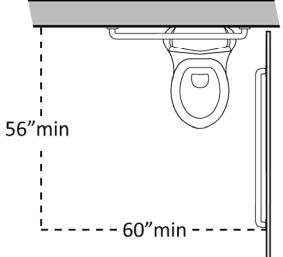
Lavatories (2010 Standards – 606) Note: 2010 Standards refer to sinks in toilet rooms as lavatories.				
<p>3.21 Does at least one lavatory have a clear floor space for a forward approach at least 30 inches wide and 48 inches long?</p>	<p><input checked="" type="checkbox"/> Yes <input type="checkbox"/> No</p> <p>Measurement:</p> <p>30" x 86"</p>		<p>Photo #: 3.19</p>	<ul style="list-style-type: none"> • Alter lavatory • Replace lavatory •
<p>3.22 Do no less than 17 inches and no greater than 25 inches of the clear floor space extend under the lavatory so that a person using a wheelchair can get close enough to reach the faucet?</p>	<p><input checked="" type="checkbox"/> Yes <input type="checkbox"/> No</p> <p>Measurement:</p> <p>21"</p>		<p>Photo #: 3.19</p>	<ul style="list-style-type: none"> • Alter lavatory • Replace lavatory •
<p>3.23 Is the front of the lavatory or counter surface, whichever is higher, no more than 34 inches above the floor?</p>	<p><input checked="" type="checkbox"/> Yes <input type="checkbox"/> No</p> <p>Measurement:</p> <p>34"</p>		<p>Photo #: 3.23</p>	<ul style="list-style-type: none"> • Alter lavatory • Replace lavatory •
<p>3.24 Is there at least 27 inches clearance from the floor to the bottom of the lavatory that extends at least 8 inches under the lav for knee clearance?</p>	<p><input checked="" type="checkbox"/> Yes <input type="checkbox"/> No</p> <p>Measurement:</p> <p>30"</p>		<p>Photo #: 3.23</p>	<ul style="list-style-type: none"> • Alter lavatory • Replace lavatory •

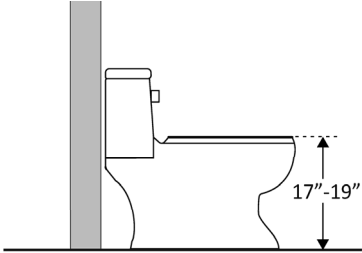
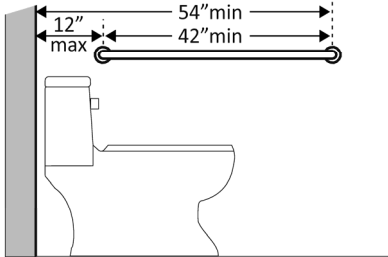
<p>3.25 Is there toe clearance at least 9 inches high? (Space extending greater than 6 inches beyond the available toe clearance at 9 inches above the floor is not considered toe clearance.)</p>	<p><input checked="" type="checkbox"/> Yes <input type="checkbox"/> No 13"</p>		<p>Photo #: 3.23</p>	<ul style="list-style-type: none"> • Alter lavatory • Replace lavatory •
<p>3.26 Are pipes below the lavatory insulated or otherwise configured to protect against contact?</p>	<p><input checked="" type="checkbox"/> Yes <input type="checkbox"/> No</p>		<p>Photo #: 3.23</p>	<ul style="list-style-type: none"> • Install insulation • Install cover panel •
<p>3.27 Can the faucet be operated without tight grasping, pinching, or twisting of the wrist? Is the force required to activate the faucet no greater than 5 pounds?</p>	<p><input checked="" type="checkbox"/> Yes <input type="checkbox"/> No <input checked="" type="checkbox"/> Yes <input type="checkbox"/> No 1 LB</p>		<p>Photo #: 3.19</p>	<ul style="list-style-type: none"> • Adjust faucet • Replace faucet •
<p>Soap Dispensers and Hand Dryers (2010 Standards – 603)</p>				
<p>3.28 Are the operable parts of the soap dispenser within one of the following reach ranges: Above lavatories or counters no less than 20 inches and no greater than 25 inches deep: no higher than 44 inches above the floor?</p>	<p><input type="checkbox"/> Yes <input checked="" type="checkbox"/> No Measurement: 49"</p>			<ul style="list-style-type: none"> • Adjust dispensers • Replace with or provide additional accessible dispensers •

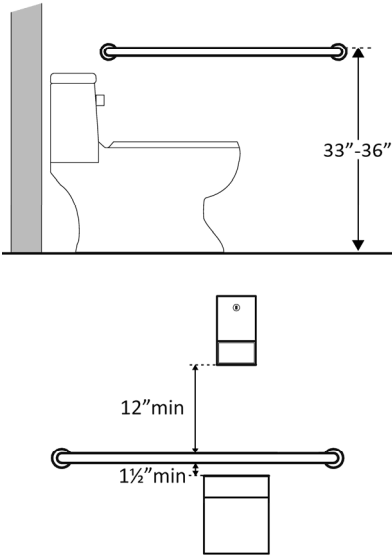
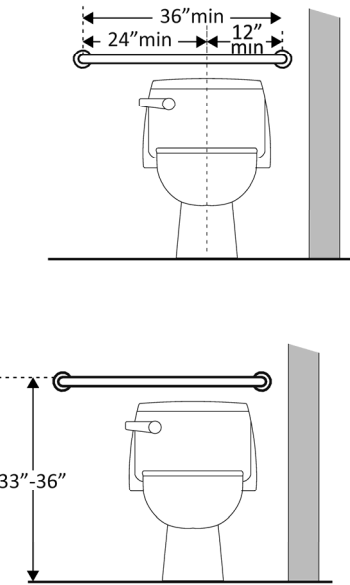
<p>Above lavatories less than 20 inches deep: no higher than 48 inches above the floor?</p> <p>Not over an obstruction: no higher than 48 inches above the floor?</p>	<p><input type="checkbox"/> Yes <input checked="" type="checkbox"/> No</p> <p>Measurement: 49"</p> <p><input type="checkbox"/> Yes <input type="checkbox"/> No</p> <p>Measurement: NA</p>		<p>Photo #: 3.19</p>
<p>3.29 Are the operable parts of the hand dryer or towel dispenser within one of the following reach ranges:</p> <p>Above lavatories or counters no less than 20 inches and no greater than 25 inches deep: no higher than 44 inches above the floor?</p> <p>Above lavatories less than 20 inches deep: no higher than 48 inches above the floor?</p> <p>Not over an obstruction: no higher than 48 inches above the floor?</p>	<p><input type="checkbox"/> Yes <input type="checkbox"/> No</p> <p>Measurement: NA</p> <p><input type="checkbox"/> Yes <input type="checkbox"/> No</p> <p>Measurement: NA</p> <p><input checked="" type="checkbox"/> Yes <input type="checkbox"/> No</p> <p>Measurement: 45"</p>		<ul style="list-style-type: none"> • Adjust dispensers • Replace with or provide additional accessible dispensers •

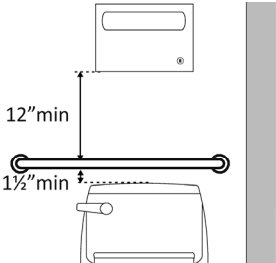
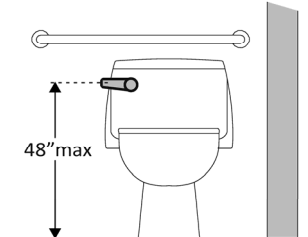
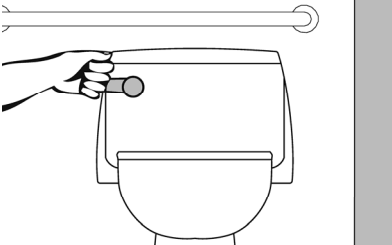
<p>Can the operable parts of the hand dryer or towel dispenser be operated without tight grasping, pinching or twisting of the wrist?</p> <p>Is the force required to activate the hand dryer or towel dispenser no greater than 5 pounds?</p>	<p><input checked="" type="checkbox"/> Yes <input type="checkbox"/> No</p> <p><input checked="" type="checkbox"/> Yes <input type="checkbox"/> No</p> <p>Measurement: 3lbs</p>		<p>Photo #: 3.29</p>	
--	---	--	-----------------------------	--

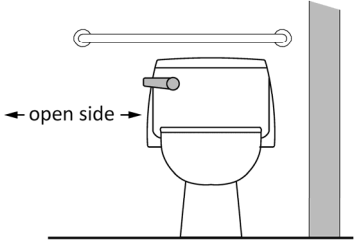
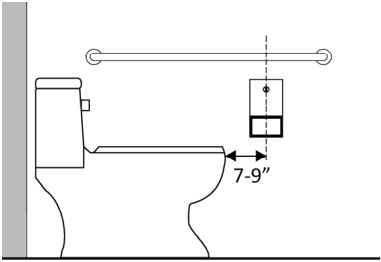
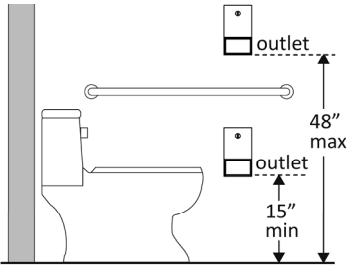
Water Closets in Single-User Toilet Rooms and Compartments (Stalls) (2010 Standards – 603 & 609) Note: 2010 Standards refer to toilets as water closets.

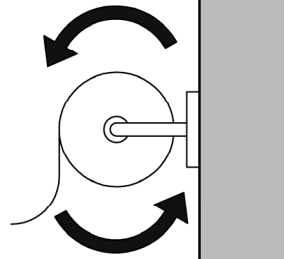
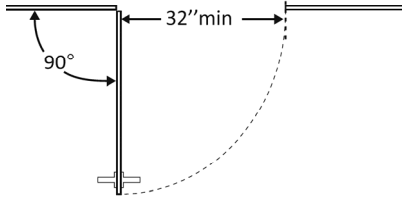
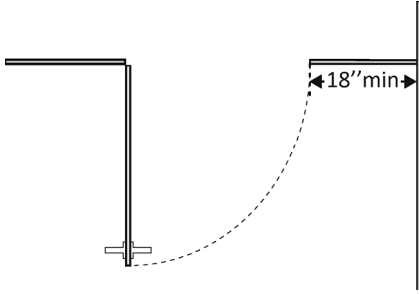
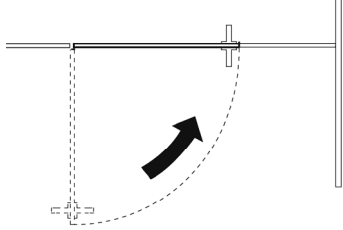
<p>3.30 Is the centerline of the water closet no less than 16 inches and no greater than 18 inches from the side wall or partition?</p>	<p><input checked="" type="checkbox"/> Yes <input type="checkbox"/> No</p> <p>Measurement: 18"</p>		<p>Photo #: 3.30</p>	<ul style="list-style-type: none"> • Move toilet • Replace toilet • Move partition •
<p>3.31 Is clearance provided around the water closet measuring at least 60 inches from the side wall and at least 56 inches from the rear wall?*</p>	<p><input type="checkbox"/> Yes <input checked="" type="checkbox"/> No</p> <p>Measurement: 18"</p>		<p>Photo #: 3.30</p>	<p>* If constructed before 3/15/12, clearances around water closets in single user toilet rooms can be 48 inches wide by 66 inches long or 48 inches wide by 56 inches long (depending on the approach to the water closet, see 1991 Standards Figure 28) and the lavatory may overlap that clearance if the door to the room does not swing into the</p>

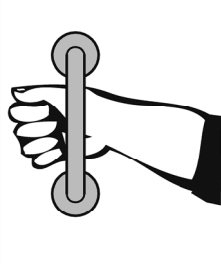
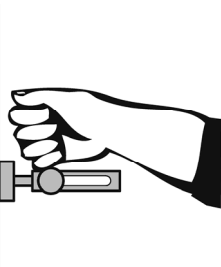
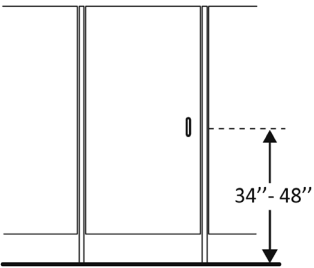
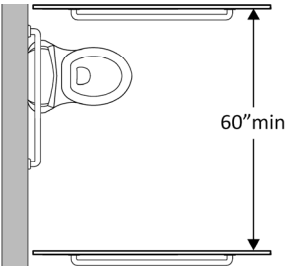
				<p>required clearances at fixtures (such as lavatories, water closet and urinals) and the edge of the lavatory is at least 18 inches from the centerline of the water closet</p> <ul style="list-style-type: none"> Alter room/compartment for clearance
<p>3.32 Is the height of the water closet no less than 17 inches and no greater than 19 inches above the floor measured to the top of the seat?</p>	<p><input checked="" type="checkbox"/> Yes <input type="checkbox"/> No</p> <p>Measurement:</p> <p>19"</p>		<p>3.30 Photo #:</p>	<ul style="list-style-type: none"> Adjust toilet height Replace toilet
<p>3.33 Is there a grab bar at least 42 inches long on the side wall?</p> <p>Is it located no more than 12 inches from the rear wall?</p> <p>Does it extend at least 54 inches from the rear wall?</p> <p>Is it mounted no less than 33 inches and no greater than 36 inches above the floor to the top of the gripping surface?</p>	<p><input checked="" type="checkbox"/> Yes <input type="checkbox"/> No Measurement: 42"</p> <p><input type="checkbox"/> Yes <input checked="" type="checkbox"/> No Measurement: 13 ½"</p> <p><input checked="" type="checkbox"/> Yes <input type="checkbox"/> No Measurement: 55 ½"</p> <p><input checked="" type="checkbox"/> Yes <input type="checkbox"/> No Measurement: 33"</p>			<ul style="list-style-type: none"> Install grab bar Relocate grab bar Relocate objects

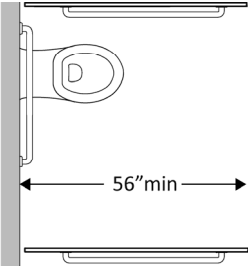
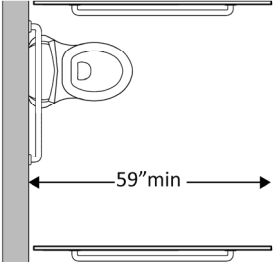
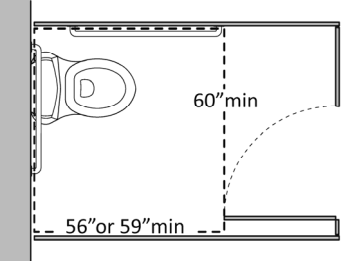
<p>Is there at least 12 inches clearance between the grab bar and protruding objects above?*</p> <p>Is there at least 1½ inches clearance between the grab bar and projecting objects below?*</p> <p>Is the space between the wall and the grab bar 1 ½ inches?</p>	<p><input type="checkbox"/> Yes <input checked="" type="checkbox"/> No Measurement: 8"</p> <p><input checked="" type="checkbox"/> Yes <input type="checkbox"/> No Measurement: NO PROTRUDING OBJECTS BELOW</p> <p><input checked="" type="checkbox"/> Yes <input type="checkbox"/> No Measurement: 1 ½"</p>		<p>Photo #: 3.30</p>	<p>* If constructed before 3/15/2012 grab bars do not need to be relocated; there are no space requirements above and below grab bars in the 1991 Standards</p>
<p>3.34 Is there a grab bar at least 36 inches long on the rear wall?</p> <p>Does it extend at least 12 inches from the centerline of the water closet on one side (side wall)?</p> <p>Does it extend at least 24 inches on the other (open) side?</p> <p>Is it mounted no less than 33 inches and no greater than 36 inches above the floor to the top of the gripping surface?</p> <p>Are there at least 12 inches clearance between the grab bar and protruding objects above?*</p>	<p><input type="checkbox"/> Yes <input checked="" type="checkbox"/> No Measurement: 30"</p> <p><input checked="" type="checkbox"/> Yes <input type="checkbox"/> No Measurement: 15"</p> <p><input type="checkbox"/> Yes <input checked="" type="checkbox"/> No Measurement: 15"</p> <p><input checked="" type="checkbox"/> Yes <input type="checkbox"/> No Measurement: 33"</p> <p><input checked="" type="checkbox"/> Yes <input type="checkbox"/> No Measurement: NO PROTUDING</p>		<p>Photo #: 3.30</p> <p>Photo #:</p>	<ul style="list-style-type: none"> • Install grab bar • Relocate grab bar • Relocate objects •

<p>Are there at least 1½ inches clearance between the grab bar and projecting objects below?*</p> <p>Is the space between the wall and the grab bar 1 ½ inches?</p>	<p>OBJECTS BELOW</p> <p><input checked="" type="checkbox"/> Yes <input type="checkbox"/> No Measurement: 13 ½"</p> <p><input checked="" type="checkbox"/> Yes <input type="checkbox"/> No Measurement: 1 ½"</p>		<p>Photo #: 3.30</p>	<p>* If constructed before 3/15/2012 grab bars do not need to be relocated; there are no space requirements above and below grab bars in the 1991 Standards</p>
<p>3.35 If the flush control is hand operated, is the operable part located no higher than 48 inches above the floor?</p>	<p><input checked="" type="checkbox"/> Yes <input type="checkbox"/> No Measurement: 36"</p>		<p>Photo #: 3.30</p>	<ul style="list-style-type: none"> • Move control • Install sensor with override button no higher than 48 inches •
<p>3.36 If the flush control is hand operated, can it be operated with one hand and without tight grasping, pinching, or twisting of the wrist?</p> <p>Is the force required to activate the flush control no greater than 5 pounds?</p>	<p><input checked="" type="checkbox"/> Yes <input type="checkbox"/> No Measurement: 1 LB</p>		<p>Photo #: 3.30</p>	<ul style="list-style-type: none"> • Change control • Adjust control •

<p>3.37 Is the flush control on the open side of the water closet?</p>	<p><input type="checkbox"/> Yes <input checked="" type="checkbox"/> No</p>		<p>Photo #: 3.30</p>	<ul style="list-style-type: none"> • Move control • •
<p>3.38 Is the toilet paper dispenser located no less than 7 inches and no greater than 9 inches from the front of the water closet to the centerline of the dispenser?*</p>	<p><input type="checkbox"/> Yes <input checked="" type="checkbox"/> No</p> <p>Measurement:</p> <p>3"</p>		<p>Photo #: 3.30</p>	<p>* If constructed before 3/15/2012 dispenser does not need to be relocated if it is within reach from the water closet seat; the 1991 Standards do not specify distance from the front of the water closet</p> <ul style="list-style-type: none"> • Relocate dispenser • •
<p>3.39 Is the outlet of the dispenser:</p> <p>Located no less than 15 inches and no greater than 48 inches above the floor?</p> <p>Not located behind grab bars?</p>	<p><input checked="" type="checkbox"/> Yes <input type="checkbox"/> No</p> <p>Measurement:</p> <p>42"</p> <p><input checked="" type="checkbox"/> Yes <input type="checkbox"/> No</p>		<p>Photo #: 3.30</p>	<ul style="list-style-type: none"> • Relocate dispenser • •

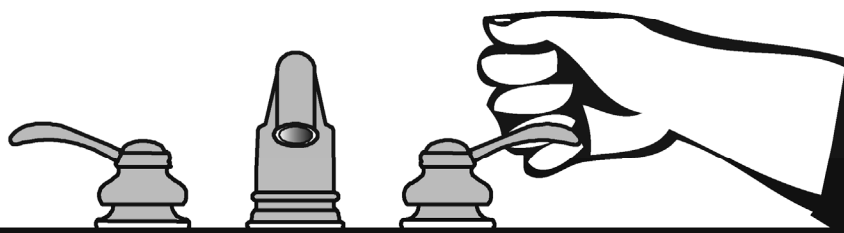
<p>3.40 Does the dispenser allow continuous paper flow?</p>	<p><input checked="" type="checkbox"/> Yes <input type="checkbox"/> No</p>		<p>Photo 3.30</p>	<ul style="list-style-type: none"> • Adjust dispenser • Replace dispenser •
<p>Toilet Compartments (Stalls) (2010 Standards – 604)</p>				
<p>3.41 Is the door opening width at least 32 inches clear, between the face of the door and the stop, when the door is open 90 degrees?</p>	<p><input checked="" type="checkbox"/> Yes <input type="checkbox"/> No</p> <p>Measurement: 32 ½"</p>		<p>Photo #: 3.41</p>	<ul style="list-style-type: none"> • Widen door width • •
<p>3.42 If there is a front approach to the pull side of the door, is there at least 18 inches of maneuvering clearance beyond the latch side plus 60 inches clear depth?*</p>	<p><input type="checkbox"/> Yes <input checked="" type="checkbox"/> No</p> <p>Measurement: 6"</p>		<p>Photo #: 3.42</p>	<p>*See 2010 Standards 604.8.1.2 Doors for maneuvering clearance requirements on the push side of the door and side approaches to the pull side of the door</p> <ul style="list-style-type: none"> • Remove obstructions •
<p>3.43 Is the door self-closing?</p>	<p><input type="checkbox"/> Yes <input checked="" type="checkbox"/> No</p>		<p>Photo #: 3.20</p>	<ul style="list-style-type: none"> • Add closer • Replace door •

<p>3.44 Are there door pulls on both sides of the door that are operable with one hand and do not require tight grasping pinching or twisting of the wrist?*</p>	<p><input checked="" type="checkbox"/> Yes <input type="checkbox"/> No</p>		<p>Photo #: 3.44</p>	<p>* If constructed before 3/15/2012 door pulls do not need to be added; door pulls are not required in the 1991 Standards</p> <ul style="list-style-type: none"> • Replace hardware • •
<p>3.45 Is the lock operable with one hand and without tight grasping, pinching or twisting of the wrist?</p>	<p><input checked="" type="checkbox"/> Yes <input type="checkbox"/> No</p>		<p>Photo #: 3.44</p>	<ul style="list-style-type: none"> • Replace lock • •
<p>3.46 Are the operable parts of the door hardware mounted no less than 34 inches and no greater than 48 inches above the floor?</p>	<p><input checked="" type="checkbox"/> Yes <input type="checkbox"/> No</p> <p>Measurement:</p> <p>48"</p>		<p>Photo #: 3.20</p>	<ul style="list-style-type: none"> • Relocate hardware • •
<p>3.47 Is the compartment at least 60 inches wide?</p>	<p><input type="checkbox"/> Yes <input checked="" type="checkbox"/> No</p> <p>Measurement:</p> <p>37"</p>		<p>Photo #: 3.42</p>	<ul style="list-style-type: none"> • Widen compartment • •

<p>3.48 If the water closet is wall hung, is the compartment at least 56 inches deep?</p>	<p><input checked="" type="checkbox"/> Yes <input type="checkbox"/> No</p> <p>Measurement:</p> <p>65"</p>		<p>Photo #: 3.42</p>	<ul style="list-style-type: none"> • Widen compartment • •
<p>3.49 If the water closet is floor mounted, is the compartment at least 59 inches deep?</p>	<p><input type="checkbox"/> Yes <input type="checkbox"/> No</p> <p>Measurement:</p>		<p>Photo #: NA</p>	<ul style="list-style-type: none"> • Alter compartment • •
<p>3.50 If the door swings in, is the minimum required compartment area provided beyond the swing of the door (60 inches x 56 inches if water closet is wall hung or 59 inches if water closet is floor mounted)?</p>	<p><input type="checkbox"/> Yes <input type="checkbox"/> No</p> <p>Measurement:</p>		<p>Photo #: NA</p>	<ul style="list-style-type: none"> • Reverse door swing • Alter compartment •
	<p><input type="checkbox"/> Yes <input type="checkbox"/> No</p>		<p>Photo #:</p>	<ul style="list-style-type: none"> • • •
	<p><input type="checkbox"/> Yes <input type="checkbox"/> No</p>		<p>Photo #:</p>	<ul style="list-style-type: none"> • • •

The ADA Checklist for Readily Achievable Barrier Removal

Priority 3 – Women’s Toilet Rooms



Project **SDDOT Rest Area Improvements**
FHU Reference Number 13-039-01
TSP Project Number 03120855

Building **HIDEWOOD NORTH**

Location **29 N., MRM 160**

Date **09-17-2013 (Inspection)**

Surveyors **Timothy Roach, AIA**
Todd Schultz, PE

Robert King, CPD

Contact Information **TSP – (605) 343-6102**



When toilet rooms are open to the public they should be accessible to people with disabilities.



Institute for Human Centered Design
www.HumanCenteredDesign.org
November 2011



ADA National Network
Questions on the ADA 800-949-4232 voice/tty
www.ADAchecklist.org

Priority 3 – Toilet Rooms		Comments	Possible Solutions
<p>3.1 If toilet rooms are available to the public, is at least one toilet room accessible? (Either one for each sex, or one unisex.)</p> <p><input checked="" type="checkbox"/> Yes <input type="checkbox"/> No</p>		Photo #: 3.7	<ul style="list-style-type: none"> • Reconfigure toilet rooms • Combine toilet rooms to create one unisex accessible toilet room
<p>3.2 Are there signs at inaccessible toilet rooms that give directions to accessible toilet rooms?</p> <p><input type="checkbox"/> Yes <input type="checkbox"/> No</p>		<p>NA</p> <p>Photo #:</p>	<ul style="list-style-type: none"> • Install signs • •
<p>3.3 If not all toilet rooms are accessible, is there a sign at the accessible toilet room with the International Symbol of Accessibility?</p> <p><input type="checkbox"/> Yes <input type="checkbox"/> No</p>		<p>NA</p> <p>Photo #:</p>	<ul style="list-style-type: none"> • Install sign • •
<p>Accessible Route (2010 Standards – Chapter 4)</p>			
<p>3.4 Is there a route to the accessible toilet room(s) that does not include the use of stairs?</p> <p><input checked="" type="checkbox"/> Yes <input type="checkbox"/> No</p>			<ul style="list-style-type: none"> • Alter route • •
<p>Is the route accessible? (See</p> <p><input checked="" type="checkbox"/> Yes <input type="checkbox"/> No</p>			

Priority 2 Interior Accessible Route for specifics.)

Photo #: 3.4

Signs at Toilet Rooms (2010 Standards – 703)

3.5 Do text characters contrast with their backgrounds?

Yes No

Are text characters raised?

Yes No

Is there Braille?

Yes No

Is the sign mounted:
On the wall on the latch side of the door?

Yes No

Note:

Signs are permitted on the push side of doors with closers and without hold-open devices.

With clear floor space beyond the arc of the door swing between the closed position and 45-degree open position, at least 18 x 18 inches centered on the tactile characters? *

Yes No

Measurement:

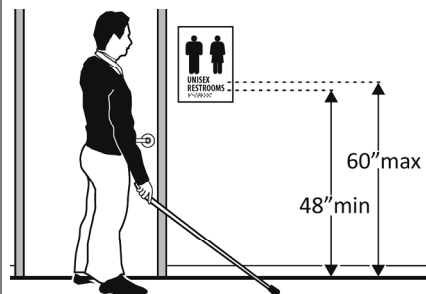
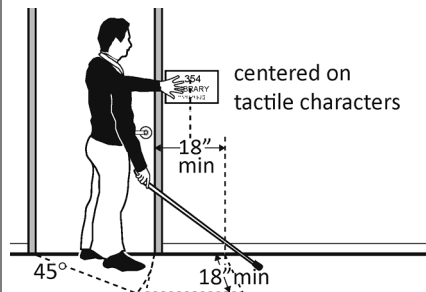
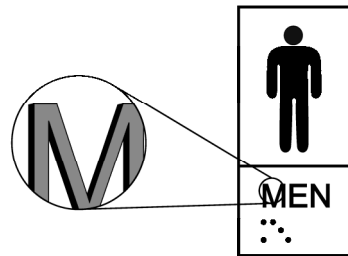
NA

So the baseline of the lowest character is at least 48 inches above the floor and the baseline of the highest character is no more than 60 inches above the floor? *

Yes No

Measurement:

NA



- Install tactile sign
- Relocate sign
-

*If constructed before 3/15/2010 and a person may approach within 3 inches of the sign without encountering protruding objects or standing within the door swing, relocation not required

*If constructed before 3/15/2012 and mounted no higher than 60 inches to the centerline of the sign, relocation is not required

Note:

If the sign is at double doors with one active leaf, the sign should be on the inactive leaf; if both leaves are active, the sign should be on the wall to the right of the right leaf.

Photo #: **3.7**

Entrance (2010 Standards – 404)

3.6 Is the door opening width at least 32 inches clear, between the face of the door and the stop, when the door is open 90 degrees?

Yes No

Measurement:
32"

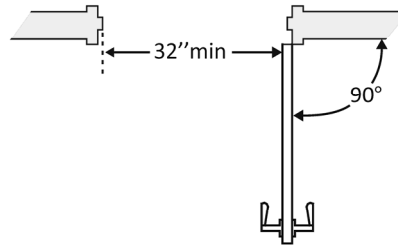


Photo #: **3.6**

- Install offset hinges
- Alter the doorway
-

3.7 If there is a front approach to the pull side of the door is there at least 18 inches of maneuvering clearance beyond the latch side plus 60 inches clear depth?

Yes No

Measurement:
6"

Yes No

Measurement:

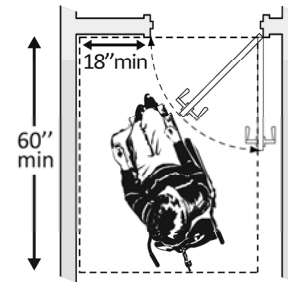
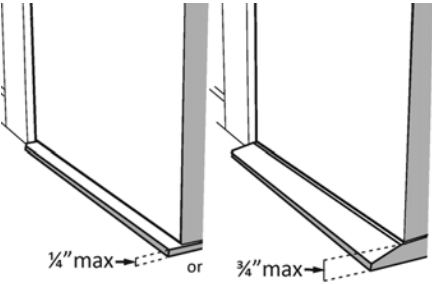

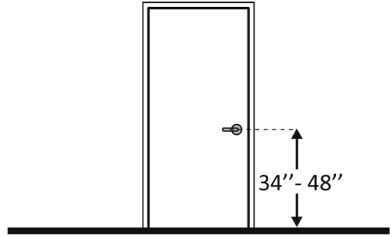

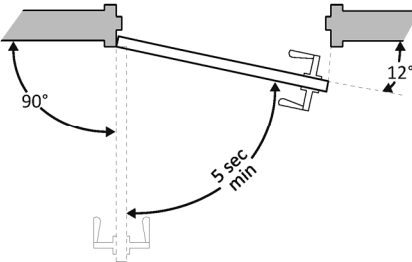
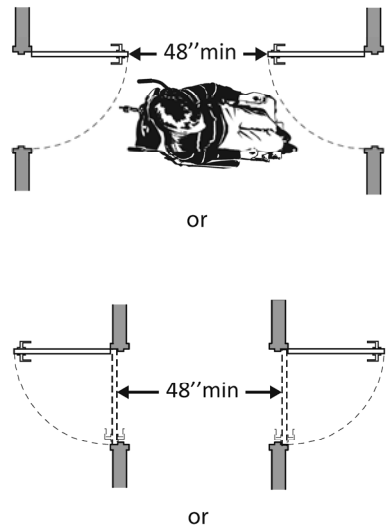


Photo #: **3.7**

- Remove obstructions
- Reconfigure walls
- Add automatic door opener

See 2010 Standards 404.2.4 for maneuvering clearance requirements on the push side of the door and side approaches to the pull side of the door

<p>3.8 Is the door threshold edge no more than ¼ inch high?</p> <p>Or</p> <p>No more than ¾ inch high if slope is beveled no steeper than 1:2?</p> <p>Note: The first ¼ inch of the threshold may be vertical; the rest must be beveled.</p>	<p><input type="checkbox"/> Yes <input type="checkbox"/> No</p> <p>Measurement:</p> <p><input type="checkbox"/> Yes <input type="checkbox"/> No</p> <p>Measurement:</p>		<p style="text-align: center;">NA</p> <p>Photo #:</p>	<ul style="list-style-type: none"> • Remove or replace threshold • •
<p>3.9 Is the door equipped with hardware that is operable with one hand and does not require tight grasping, pinching, or twisting of the wrist?</p> <p>Check door handle and lock (if provided).</p>	<p><input checked="" type="checkbox"/> Yes <input type="checkbox"/> No</p> <p>Measurement:</p>		<p>Photo #: 3.9</p>	<ul style="list-style-type: none"> • Replace knobs or latches with lever or loop handles • Install power-assisted or automatic door openers •
<p>3.10 Are the operable parts of the door hardware mounted no less than 34 inches and no greater than 48 inches above the floor?</p>	<p><input checked="" type="checkbox"/> Yes <input type="checkbox"/> No</p> <p>Measurement:</p> <p>32" Bottom</p> <p>48" Top</p>		<p>Photo #: 3.10</p>	<ul style="list-style-type: none"> • Change hardware height • •

<p>3.11 Can the door be opened easily (5 pounds maximum force)?</p>	<p><input type="checkbox"/> Yes <input checked="" type="checkbox"/> No</p> <p>Measurement:</p> <p>7 lbs.</p>		<p>Photo #: 3.9</p>	<ul style="list-style-type: none"> • Adjust or replace closers • Install lighter doors • Install power-assisted or automatic door openers
<p>3.12 If the door has a closer, does it take at least 5 seconds to close from an open position of 90 degrees to a position of 12 degrees from the latch?</p>	<p><input type="checkbox"/> Yes <input checked="" type="checkbox"/> No</p> <p>Measurement:</p> <p>3 sec.</p>		<p>Photo #: 3.9</p>	<ul style="list-style-type: none"> • Adjust closer • •
<p>3.13 If there are two doors in a series, e.g. vestibule, is the distance between the doors at least 48 inches plus the width of the doors when swinging into the space?</p>	<p><input type="checkbox"/> Yes <input type="checkbox"/> No</p> <p>Measurement:</p>		<p>NA</p>	<ul style="list-style-type: none"> • Remove inner door • Change door swing •

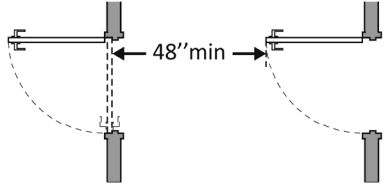
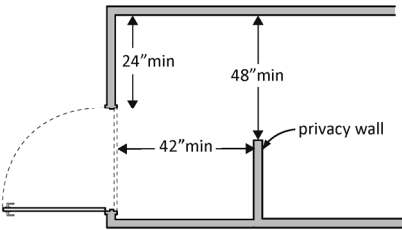
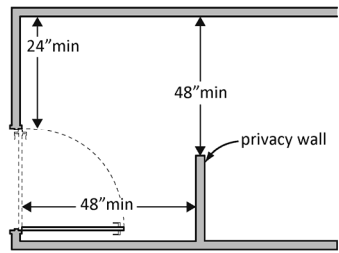

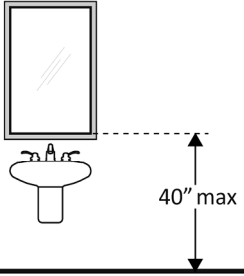
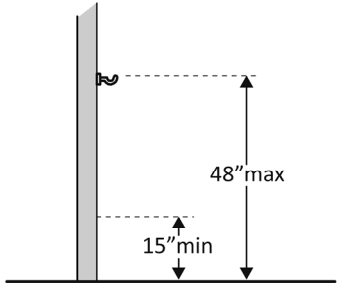
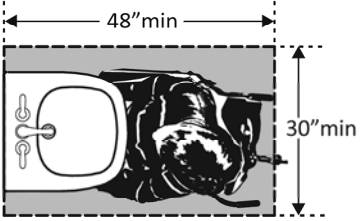
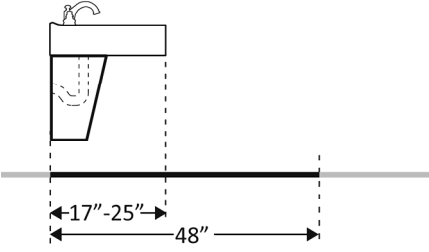
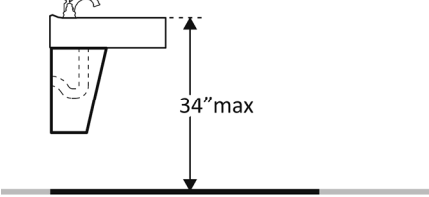
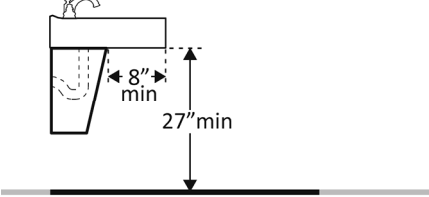
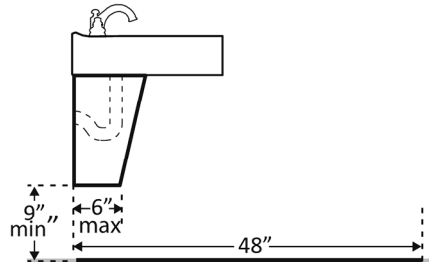
			<p>Photo #:</p>	
<p>3.14 If there is a privacy wall and the door swings out, is there at least 24 inches of maneuvering clearance beyond the door latch side and 42 inches to the privacy wall?</p>	<p><input type="checkbox"/> Yes <input type="checkbox"/> No</p> <p>Measurement:</p>		<p style="text-align: center; color: red;">NA</p> <p>Photo #:</p>	<ul style="list-style-type: none"> • Reconfigure space • •
<p>3.15 If there is a privacy wall and the door swings in, is there at least 24 inches of maneuvering clearance beyond the door latch side and at least 48 inches to the privacy wall if there is no door closer or at least 54 inches if there is a door closer?</p>	<p><input type="checkbox"/> Yes <input type="checkbox"/> No</p> <p>Measurement:</p>		<p style="text-align: center; color: red;">NA</p> <p>Photo #:</p>	<ul style="list-style-type: none"> • Reconfigure space • •
<p>In the Toilet Room</p>				
<p>3.16 Is there a clear path to at least one of each type of fixture, e.g. lavatory, hand dryer, etc., that is at least 36 inches wide?</p>	<p><input checked="" type="checkbox"/> Yes <input type="checkbox"/> No</p> <p>Measurement:</p> <p style="color: red; font-weight: bold;">44"</p>		<p>Photo #:</p>	<ul style="list-style-type: none"> • Remove obstructions • •

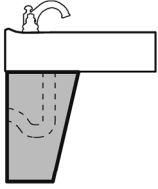

			Photo #: 3.20	
<p>3.17 Is there clear floor space available for a person in a wheelchair to turn around, i.e. a circle at least 60 inches in diameter or a T-shaped space within a 60-inch square?*</p>	<p><input checked="" type="checkbox"/> Yes <input type="checkbox"/> No</p> <p>Measurement: 86" x 106"</p>		Photo #: 3.29	<p>*The door to the toilet room may swing into the required turning space</p> <ul style="list-style-type: none"> • Move or remove partitions, fixtures or objects such as trash cans • •
<p>3.18 In a single user toilet room if the door swings in and over a clear floor space at an accessible fixture, is there a clear floor space at least 30 x 48 inches beyond the swing of the door?</p>	<p><input type="checkbox"/> Yes <input type="checkbox"/> No</p> <p>Measurement:</p>		<p>NA</p> <p>Photo #:</p>	<ul style="list-style-type: none"> • Reverse door swing • Alter toilet room •
<p>3.19 If the mirror is over a lavatory or countertop, is the bottom edge of the reflecting surface no higher than 40 inches above the floor? Or If the mirror is not over the lavatory or countertop, is the</p>	<p><input checked="" type="checkbox"/> Yes <input type="checkbox"/> No</p> <p>Measurement: 39"</p>	-		<p>* If installed before 3/15/2012 and the bottom edge of the reflecting surface is no higher than 40 inches above the floor, lowering the mirror to 35 inches is not required</p>

<p>bottom edge of the reflecting surface no higher than 35 inches above the floor?*</p>	<p><input type="checkbox"/> Yes <input type="checkbox"/> No</p> <p>Measurement: NA</p>		<p>Photo #: 3.28</p>	<ul style="list-style-type: none"> • Lower the mirror • Add another mirror •
<p>3.20 If there is a coat hook, is it no less than 15 inches and no greater than 48 inches above the floor?</p>	<p><input checked="" type="checkbox"/> Yes <input type="checkbox"/> No</p> <p>Measurement: 46"</p>		<p>Photo #: 3.20</p>	<ul style="list-style-type: none"> • Adjust hook • Replace with or provide additional accessible hook •

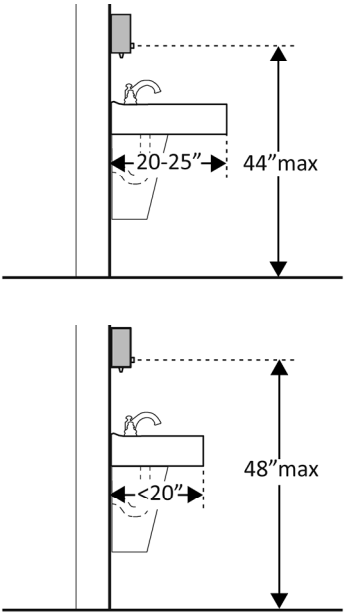
Lavatories (2010 Standards – 606) Note: 2010 Standards refer to sinks in toilet rooms as lavatories.

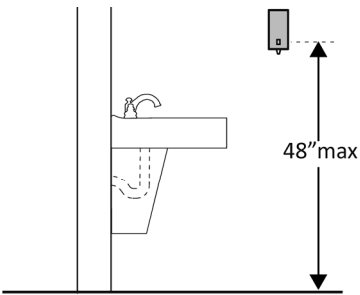
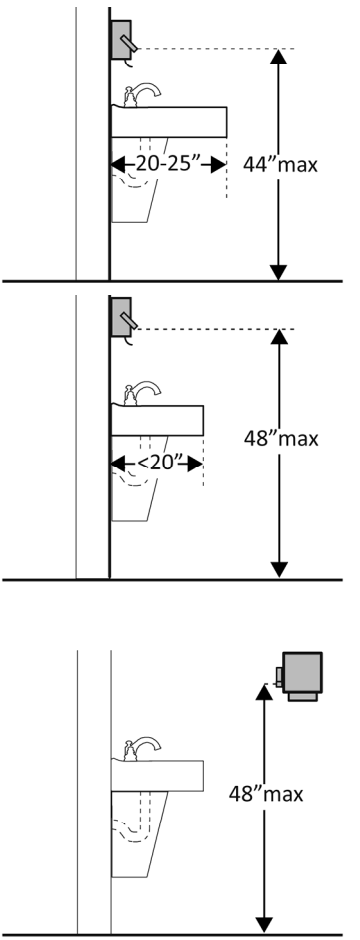
<p>3.21 Does at least one lavatory have a clear floor space for a forward approach at least 30 inches wide and 48 inches long?</p>	<p><input checked="" type="checkbox"/> Yes <input type="checkbox"/> No</p> <p>Measurement: 30" X 86"</p>		<p>Photo #: 3.28</p>	<ul style="list-style-type: none"> • Alter lavatory • Replace lavatory •
---	---	--	-----------------------------	---

<p>3.22 Do no less than 17 inches and no greater than 25 inches of the clear floor space extend under the lavatory so that a person using a wheelchair can get close enough to reach the faucet?</p>	<p><input checked="" type="checkbox"/> Yes <input type="checkbox"/> No</p> <p>Measurement:</p> <p>21"</p>		<p>Photo #: 3.28</p>	<ul style="list-style-type: none"> • Alter lavatory • Replace lavatory •
<p>3.23 Is the front of the lavatory or counter surface, whichever is higher, no more than 34 inches above the floor?</p>	<p><input checked="" type="checkbox"/> Yes <input type="checkbox"/> No</p> <p>Measurement:</p> <p>34"</p>		<p>Photo #: 3.28</p>	<ul style="list-style-type: none"> • Alter lavatory • Replace lavatory •
<p>3.24 Is there at least 27 inches clearance from the floor to the bottom of the lavatory that extends at least 8 inches under the lav for knee clearance?</p>	<p><input checked="" type="checkbox"/> Yes <input type="checkbox"/> No</p> <p>Measurement:</p> <p>30"</p>		<p>Photo #: 3.28</p>	<ul style="list-style-type: none"> • Alter lavatory • Replace lavatory •
<p>3.25 Is there toe clearance at least 9 inches high?</p> <p>(Space extending greater than 6 inches beyond the available toe clearance at 9 inches above the floor is not considered toe clearance.)</p>	<p><input checked="" type="checkbox"/> Yes <input type="checkbox"/> No</p> <p>13"</p>		<p>Photo #: 3.28</p>	<ul style="list-style-type: none"> • Alter lavatory • Replace lavatory •

<p>3.26 Are pipes below the lavatory insulated or otherwise configured to protect against contact?</p>	<p><input checked="" type="checkbox"/> Yes <input type="checkbox"/> No</p>		<p>Photo #: 3.28</p>	<ul style="list-style-type: none"> • Install insulation • Install cover panel •
<p>3.27 Can the faucet be operated without tight grasping, pinching, or twisting of the wrist?</p> <p>Is the force required to activate the faucet no greater than 5 pounds?</p>	<p><input checked="" type="checkbox"/> Yes <input type="checkbox"/> No</p> <p><input checked="" type="checkbox"/> Yes <input type="checkbox"/> No 1 LB</p>		<p>Photo #: 3.28</p>	<ul style="list-style-type: none"> • Adjust faucet • Replace faucet •

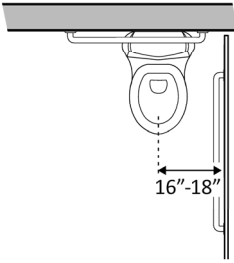
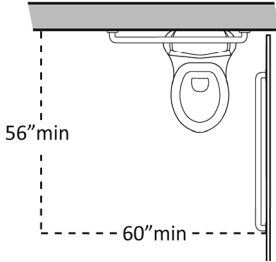
Soap Dispensers and Hand Dryers (2010 Standards – 603)

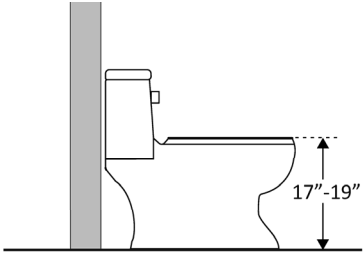
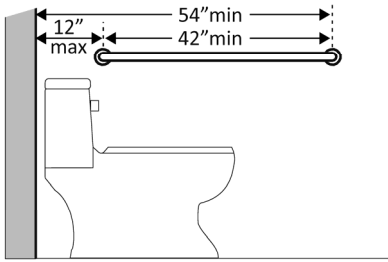
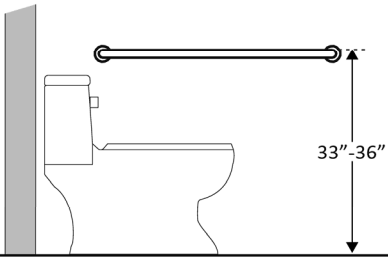
<p>3.28 Are the operable parts of the soap dispenser within one of the following reach ranges:</p> <p>Above lavatories or counters no less than 20 inches and no greater than 25 inches deep: no higher than 44 inches above the floor?</p> <p>Above lavatories less than 20 inches deep: no higher than 48 inches above the floor?</p> <p>Not over an obstruction: no higher than 48 inches above the</p>	<p><input type="checkbox"/> Yes <input checked="" type="checkbox"/> No</p> <p>Measurement: 49"</p> <p><input type="checkbox"/> Yes <input checked="" type="checkbox"/> No</p> <p>Measurement: 49"</p> <p><input type="checkbox"/> Yes <input type="checkbox"/> No</p>		<p>Photo #: 3.28</p>	<ul style="list-style-type: none"> • Adjust dispensers • Replace with or provide additional accessible dispensers •
---	---	---	-----------------------------	--

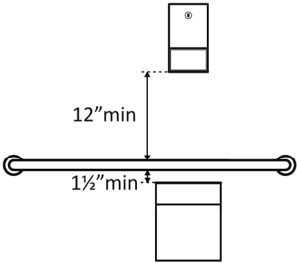
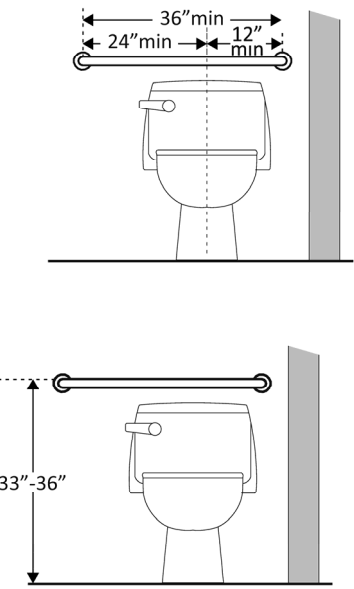
<p>floor?</p>	<p>Measurement: NA</p>		<p>Photo #: 3.28</p>
<p>3.29 Are the operable parts of the hand dryer or towel dispenser within one of the following reach ranges:</p> <p>Above lavatories or counters no less than 20 inches and no greater than 25 inches deep: no higher than 44 inches above the floor?</p> <p>Above lavatories less than 20 inches deep: no higher than 48 inches above the floor?</p> <p>Not over an obstruction: no higher than 48 inches above the floor?</p> <p>Can the operable parts of the hand dryer or towel dispenser be operated without tight grasping, pinching or twisting of the wrist?</p> <p>Is the force required to activate the hand dryer or towel</p>	<p><input type="checkbox"/> Yes <input type="checkbox"/> No Measurement: NA</p> <p><input type="checkbox"/> Yes <input type="checkbox"/> No Measurement: NA</p> <p><input checked="" type="checkbox"/> Yes <input type="checkbox"/> No Measurement: 45"</p> <p><input checked="" type="checkbox"/> Yes <input type="checkbox"/> No Measurement:</p>		<ul style="list-style-type: none"> • Adjust dispensers • Replace with or provide additional accessible dispensers •

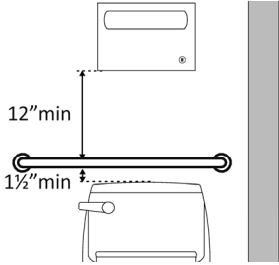
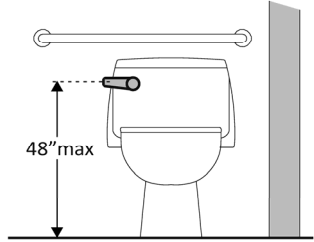
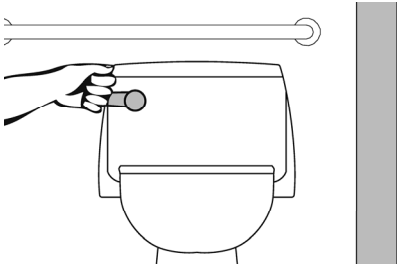
dispenser no greater than 5 pounds?	3 lbs		Photo #: 3.29	
-------------------------------------	--------------	--	----------------------	--

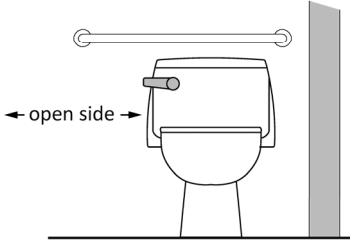
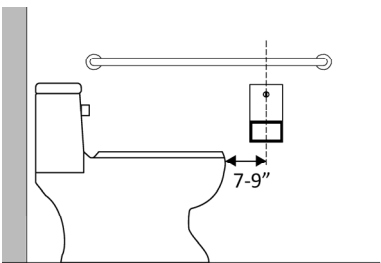
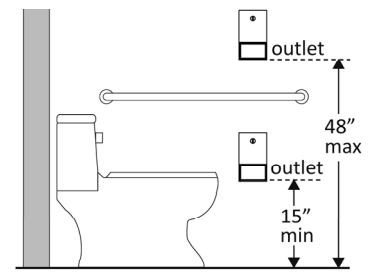
Water Closets in Single-User Toilet Rooms and Compartments (Stalls) (2010 Standards – 603 & 609) Note: 2010 Standards refer to toilets as water closets.

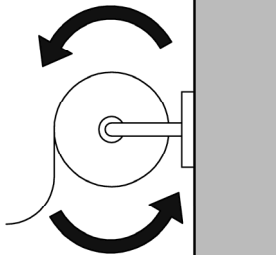
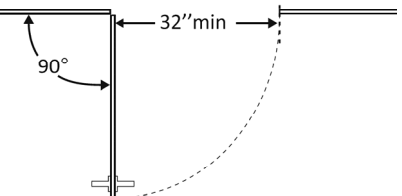
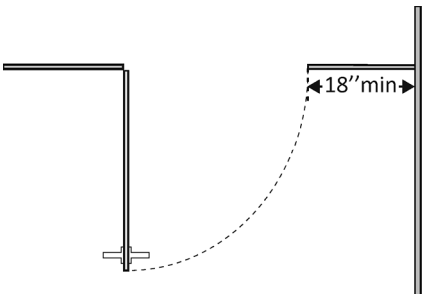
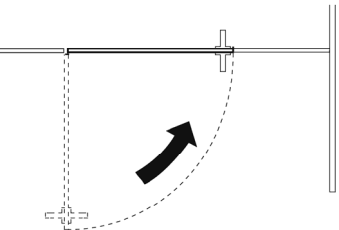
<p>3.30 Is the centerline of the water closet no less than 16 inches and no greater than 18 inches from the side wall or partition?</p>	<p><input checked="" type="checkbox"/> Yes <input type="checkbox"/> No</p> <p>Measurement:</p> <p>18"</p>		<p>Photo #: 3.30</p>	<ul style="list-style-type: none"> • Move toilet • Replace toilet • Move partition •
<p>3.31 Is clearance provided around the water closet measuring at least 60 inches from the side wall and at least 56 inches from the rear wall?*</p>	<p><input type="checkbox"/> Yes <input checked="" type="checkbox"/> No</p> <p>Measurement:</p> <p>18"</p>		<p>Photo #: 3.30</p>	<p>* If constructed before 3/15/12, clearances around water closets in single user toilet rooms can be 48 inches wide by 66 inches long or 48 inches wide by 56 inches long (depending on the approach to the water closet, see 1991 Standards Figure 28) and the lavatory may overlap that clearance if the door to the room does not swing into the required clearances at fixtures (such as</p>

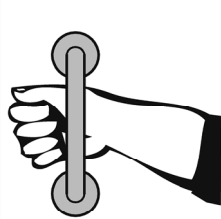
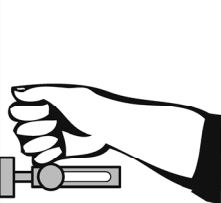
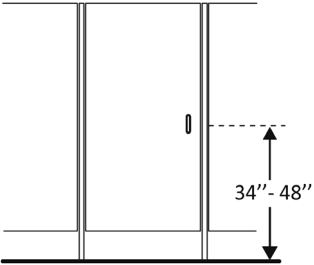
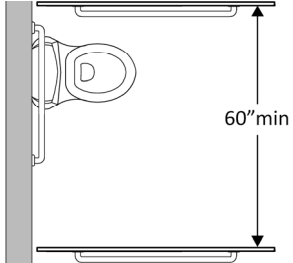
			<p>Photo #: 3.30</p>	<p>lavatories, water closet and urinals) and the edge of the lavatory is at least 18 inches from the centerline of the water closet</p> <ul style="list-style-type: none"> Alter room/compartments for clearance
<p>3.32 Is the height of the water closet no less than 17 inches and no greater than 19 inches above the floor measured to the top of the seat?</p>	<p><input checked="" type="checkbox"/> Yes <input type="checkbox"/> No Measurement: 19"</p>		<p>Photo #: 3.30</p>	<ul style="list-style-type: none"> Adjust toilet height Replace toilet
<p>3.33 Is there a grab bar at least 42 inches long on the side wall?</p> <p>Is it located no more than 12 inches from the rear wall?</p> <p>Does it extend at least 54 inches from the rear wall?</p> <p>Is it mounted no less than 33 inches and no greater than 36 inches above the floor to the top of the gripping surface?</p> <p>Is there at least 12 inches</p>	<p><input checked="" type="checkbox"/> Yes <input type="checkbox"/> No Measurement: 42"</p> <p><input type="checkbox"/> Yes <input checked="" type="checkbox"/> No Measurement: 13 1/2"</p> <p><input checked="" type="checkbox"/> Yes <input type="checkbox"/> No Measurement: 55 1/2"</p> <p><input checked="" type="checkbox"/> Yes <input type="checkbox"/> No Measurement: 33"</p>	 	<p>Photo #: 3.30</p>	<ul style="list-style-type: none"> Install grab bar Relocate grab bar Relocate objects <p>* If constructed before 3/15/2012 grab bars do</p>

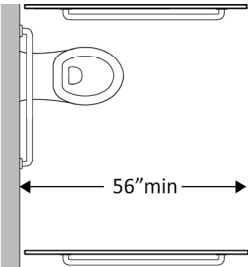
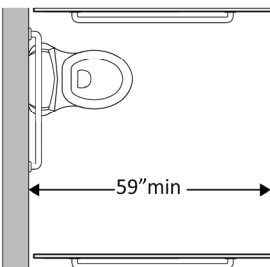
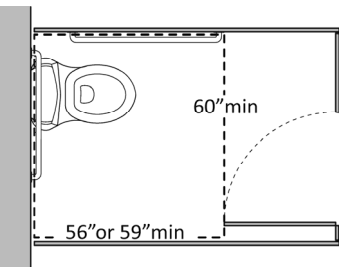
<p>clearance between the grab bar and protruding objects above?*</p> <p>Is there at least 1½ inches clearance between the grab bar and projecting objects below?*</p> <p>Is the space between the wall and the grab bar 1 ½ inches?</p>	<p><input type="checkbox"/> Yes <input checked="" type="checkbox"/> No</p> <p>Measurement: 8"</p> <p><input checked="" type="checkbox"/> Yes <input type="checkbox"/> No</p> <p>Measurement: NO PROTRUDING OBJECTS BELOW</p> <p><input checked="" type="checkbox"/> Yes <input type="checkbox"/> No</p> <p>Measurement: 1 ½"</p>		<p>Photo #: 3.30</p>	<p>not need to be relocated; there are no space requirements above and below grab bars in the 1991 Standards</p>
<p>3.34 Is there a grab bar at least 36 inches long on the rear wall?</p> <p>Does it extend at least 12 inches from the centerline of the water closet on one side (side wall)?</p> <p>Does it extend at least 24 inches on the other (open) side?</p> <p>Is it mounted no less than 33 inches and no greater than 36 inches above the floor to the top of the gripping surface?</p> <p>Are there at least 12 inches clearance between the grab bar and protruding objects above?*</p>	<p><input type="checkbox"/> Yes <input checked="" type="checkbox"/> No</p> <p>Measurement: 30"</p> <p><input checked="" type="checkbox"/> Yes <input type="checkbox"/> No</p> <p>Measurement: 15"</p> <p><input type="checkbox"/> Yes <input checked="" type="checkbox"/> No</p> <p>Measurement: 15"</p> <p><input checked="" type="checkbox"/> Yes <input type="checkbox"/> No</p> <p>Measurement: 33"</p> <p><input type="checkbox"/> Yes <input checked="" type="checkbox"/> No</p> <p>Measurement:</p>		<p>Photo #: 3.30</p> <p>Photo #: 3.30</p>	<ul style="list-style-type: none"> • Install grab bar • Relocate grab bar • Relocate objects • <p>* If constructed before 3/15/2012 grab bars do</p>

<p>Are there at least 1½ inches clearance between the grab bar and projecting objects below?*</p> <p>Is the space between the wall and the grab bar 1 ½ inches?</p>	<p>TAMPON DISPENSER 4" ABOVE</p> <p><input checked="" type="checkbox"/> Yes <input type="checkbox"/> No</p> <p>Measurement: 13 ½"</p> <p><input checked="" type="checkbox"/> Yes <input type="checkbox"/> No</p> <p>Measurement: 1 ½"</p>		<p>Photo #: 3.30</p>	<p>not need to be relocated; there are no space requirements above and below grab bars in the 1991 Standards</p>
<p>3.35 If the flush control is hand operated, is the operable part located no higher than 48 inches above the floor?</p>	<p><input checked="" type="checkbox"/> Yes <input type="checkbox"/> No</p> <p>Measurement: 36"</p>		<p>Photo #: 3.30</p>	<ul style="list-style-type: none"> • Move control • Install sensor with override button no higher than 48 inches •
<p>3.36 If the flush control is hand operated, can it be operated with one hand and without tight grasping, pinching, or twisting of the wrist?</p> <p>Is the force required to activate the flush control no greater than 5 pounds?</p>	<p><input checked="" type="checkbox"/> Yes <input type="checkbox"/> No</p> <p><input checked="" type="checkbox"/> Yes <input type="checkbox"/> No</p> <p>Measurement: 1 LB</p>		<p>Photo #: 3.30</p>	<ul style="list-style-type: none"> • Change control • Adjust control •

<p>3.37 Is the flush control on the open side of the water closet?</p>	<p><input type="checkbox"/> Yes <input checked="" type="checkbox"/> No</p>		<p>Photo #: 3.30</p>	<ul style="list-style-type: none"> • Move control • •
<p>3.38 Is the toilet paper dispenser located no less than 7 inches and no greater than 9 inches from the front of the water closet to the centerline of the dispenser?*</p>	<p><input type="checkbox"/> Yes <input checked="" type="checkbox"/> No</p> <p>Measurement:</p> <p>3"</p>		<p>Photo #: 3.28</p>	<p>* If constructed before 3/15/2012 dispenser does not need to be relocated if it is within reach from the water closet seat; the 1991 Standards do not specify distance from the front of the water closet</p> <ul style="list-style-type: none"> • Relocate dispenser • •
<p>3.39 Is the outlet of the dispenser:</p> <p>Located no less than 15 inches and no greater than 48 inches above the floor?</p> <p>Not located behind grab bars?</p>	<p><input checked="" type="checkbox"/> Yes <input type="checkbox"/> No</p> <p>Measurement:</p> <p>42"</p> <p><input type="checkbox"/> Yes <input type="checkbox"/> No</p>		<p>Photo #: 3.28</p>	<ul style="list-style-type: none"> • Relocate dispenser • •

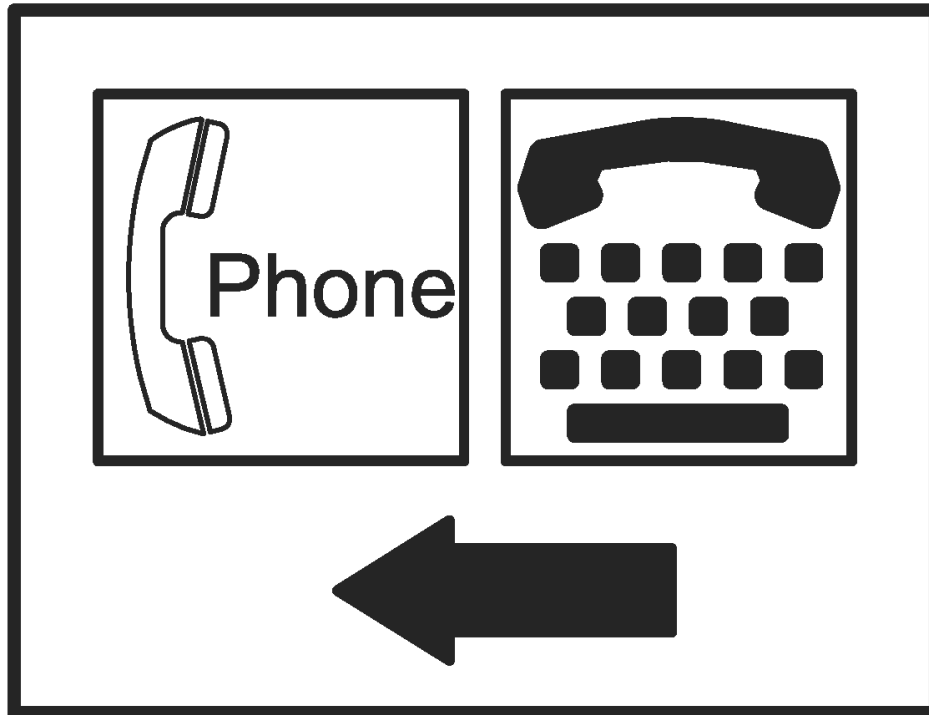
<p>3.40 Does the dispenser allow continuous paper flow?</p>	<p><input checked="" type="checkbox"/> Yes <input type="checkbox"/> No</p>		<p>Photo #: 3.28</p>	<ul style="list-style-type: none"> • Adjust dispenser • Replace dispenser •
<p>Toilet Compartments (Stalls) (2010 Standards – 604)</p>				
<p>3.41 Is the door opening width at least 32 inches clear, between the face of the door and the stop, when the door is open 90 degrees?</p>	<p><input checked="" type="checkbox"/> Yes <input type="checkbox"/> No</p> <p>Measurement: 32 ½"</p>		<p>Photo #: 3.41</p>	<ul style="list-style-type: none"> • Widen door width • •
<p>3.42 If there is a front approach to the pull side of the door, is there at least 18 inches of maneuvering clearance beyond the latch side plus 60 inches clear depth?*</p>	<p><input type="checkbox"/> Yes <input checked="" type="checkbox"/> No</p> <p>Measurement: 6"</p>		<p>Photo #: 3.30</p>	<p>*See 2010 Standards 604.8.1.2 Doors for maneuvering clearance requirements on the push side of the door and side approaches to the pull side of the door</p> <ul style="list-style-type: none"> • Remove obstructions •
<p>3.43 Is the door self-closing?</p>	<p><input type="checkbox"/> Yes <input checked="" type="checkbox"/> No</p>		<p>Photo #: 3.30</p>	<ul style="list-style-type: none"> • Add closer • Replace door •

<p>3.44 Are there door pulls on both sides of the door that are operable with one hand and do not require tight grasping pinching or twisting of the wrist?*</p>	<p><input checked="" type="checkbox"/> Yes <input type="checkbox"/> No</p>		<p>Photo #: 3.46</p>	<p>* If constructed before 3/15/2012 door pulls do not need to be added; door pulls are not required in the 1991 Standards</p> <ul style="list-style-type: none"> • Replace hardware • •
<p>3.45 Is the lock operable with one hand and without tight grasping, pinching or twisting of the wrist?</p>	<p><input checked="" type="checkbox"/> Yes <input type="checkbox"/> No</p>		<p>Photo #: 3.46</p>	<ul style="list-style-type: none"> • Replace lock • •
<p>3.46 Are the operable parts of the door hardware mounted no less than 34 inches and no greater than 48 inches above the floor?</p>	<p><input checked="" type="checkbox"/> Yes <input type="checkbox"/> No</p> <p>Measurement: 48"</p>		<p>Photo #: 3.46</p>	<ul style="list-style-type: none"> • Relocate hardware • •
<p>3.47 Is the compartment at least 60 inches wide?</p>	<p><input type="checkbox"/> Yes <input checked="" type="checkbox"/> No</p> <p>Measurement: 37"</p>		<p>Photo #: 3.30</p>	<ul style="list-style-type: none"> • Widen compartment • •

<p>3.48 If the water closet is wall hung, is the compartment at least 56 inches deep?</p>	<p><input checked="" type="checkbox"/> Yes <input type="checkbox"/> No</p> <p>Measurement: 65"</p>		<p>Photo #: 3.30</p>	<ul style="list-style-type: none"> • Widen compartment • •
<p>3.49 If the water closet is floor mounted, is the compartment at least 59 inches deep?</p>	<p><input type="checkbox"/> Yes <input type="checkbox"/> No</p> <p>Measurement:</p>		<p>Photo #: NA</p>	<ul style="list-style-type: none"> • Alter compartment • •
<p>3.50 If the door swings in, is the minimum required compartment area provided beyond the swing of the door (60 inches x 56 inches if water closet is wall hung or 59 inches if water closet is floor mounted)?</p>	<p><input type="checkbox"/> Yes <input type="checkbox"/> No</p> <p>Measurement:</p>		<p>Photo #: NA</p>	<ul style="list-style-type: none"> • Reverse door swing • Alter compartment •
	<p><input type="checkbox"/> Yes <input type="checkbox"/> No</p>		<p>Photo #:</p>	<ul style="list-style-type: none"> • • •
	<p><input type="checkbox"/> Yes <input type="checkbox"/> No</p>		<p>Photo #:</p>	<ul style="list-style-type: none"> • • •

ADA Checklist for Readily Achievable Barrier Removal

Priority 4 – Additional Access



Project **SDDOT Rest Area Improvements**

FHU Reference Number 13-039-01

TSP Project Number 03120855

Building **HIDEWOOD NORTH**

Location **29 N., MRM 160**

Date **09-17-2013 (Inspection)**

Surveyors **Timothy Roach, AIA**

Todd Schultz, PE

Robert King, CPD

Contact Information **TSP – (605) 343-6102**

Amenities such as drinking fountains and public telephones should be accessible to people with disabilities.



Institute for Human Centered Design
www.HumanCenteredDesign.org

November 2011



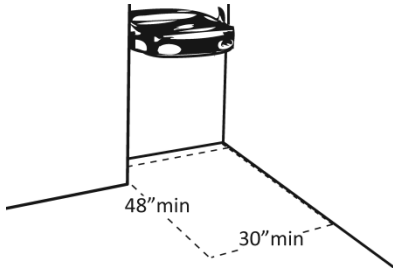
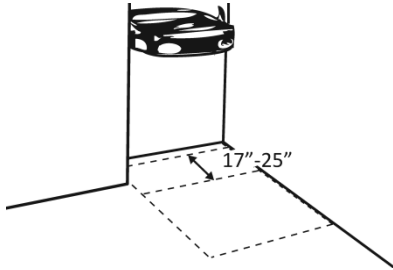
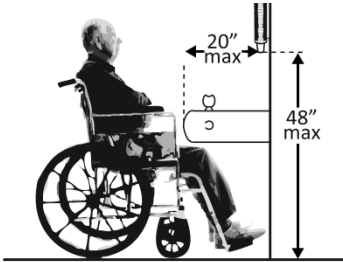
ADA National Network
Questions on the ADA 800-949-4232 voice/tty

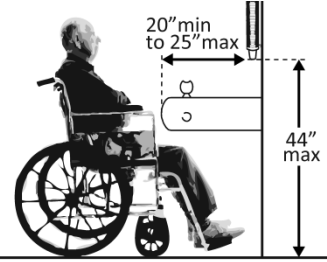

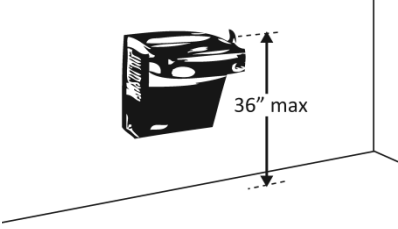
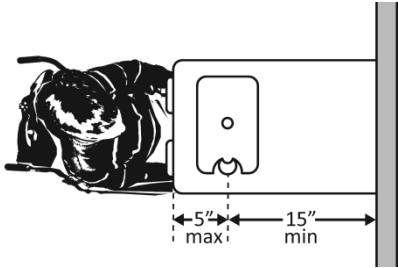
www.ADAchecklist.org

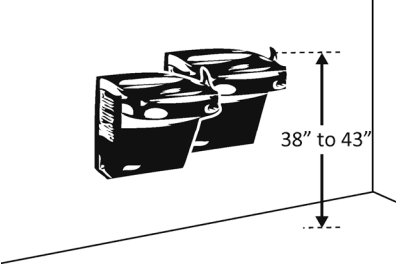
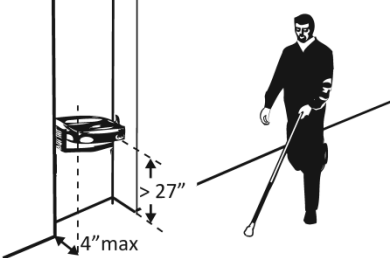
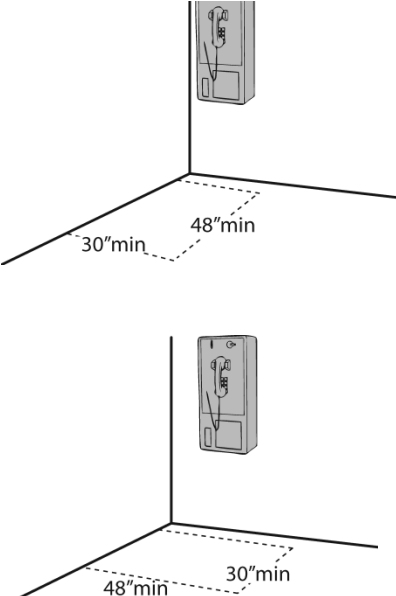
This checklist was produced by the New England ADA Center, a project of the Institute for Human Centered Design and a member of the ADA National Network. This checklist was developed under a grant from the Department of Education, NIDRR grant number H133A060092-09A. However the contents do not necessarily represent the policy of the Department of Education, and you should not assume endorsement by the Federal Government.

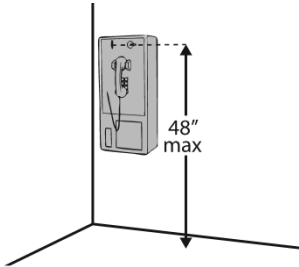
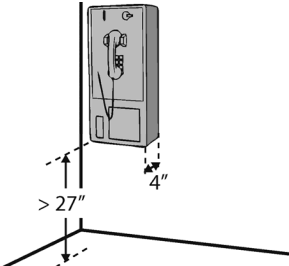


Questions or comments on the checklist contact the New England ADA Center at 617-695-0085 voice/tty or ADAinfo@NewEnglandADA.org




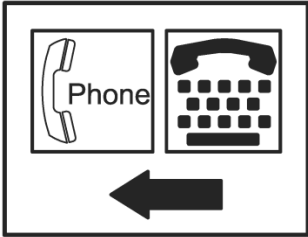
For the full set of checklists, including the checklists for recreation facilities visit www.ADAchecklist.org.




Priority 4 – Additional Access		Comments	Possible Solutions
Drinking Fountains (2010 Standards – 602)			
<p>4.1 Does at least one drinking fountain have a clear floor space at least 30 inches wide x at least 48 inches long centered in front of it for a forward approach?*</p>	<p><input checked="" type="checkbox"/> Yes <input type="checkbox"/> No</p> <p>Measurement: 48 X 30</p>		<p>Photo #: 4.7</p> <p>*If installed before 3/15/2012, a parallel approach is permitted and the clear floor space is not required to be centered</p> <ul style="list-style-type: none"> • Alter space • Relocate drinking fountain • Install a drinking fountain in another location
<p>4.2 If there is a forward approach, do no less than 17 inches and no greater than 25 inches of the clear floor space extend under the drinking fountain?</p>	<p><input type="checkbox"/> Yes <input type="checkbox"/> No</p> <p>Measurement: 19"</p>		<p>Photo 4.7</p> <ul style="list-style-type: none"> • Alter space • Replace drinking fountain •
<p>4.3 If the drinking fountain is no deeper than 20 inches, are the operable parts no higher than 48 inches above the floor?</p>	<p><input type="checkbox"/> Yes <input type="checkbox"/> No</p> <p>Measurement: 30"</p>		<p>Photo #: 4.6</p> <ul style="list-style-type: none"> • Adjust drinking fountain • Replace drinking fountain •

<p>4.4 If the drinking fountain is no less than 20 inches and no greater than 25 inches deep, are the operable parts no higher than 44 inches above the floor?</p>	<p><input type="checkbox"/> Yes <input type="checkbox"/> No Measurement:</p>		<p style="text-align: center;">NA</p> <p>Photo #:</p>	<ul style="list-style-type: none"> • Adjust drinking fountain • Replace drinking fountain •
<p>4.5 Can the control be operated with one hand and without tight grasping, pinching or twisting of the wrist?</p> <p>Is the force required to activate the control no more than 5 pounds?</p>	<p><input checked="" type="checkbox"/> Yes <input type="checkbox"/> No Measurement:</p> <p>1 LB</p>		<p>Photo #: 4.8</p>	<ul style="list-style-type: none"> • Change control • Adjust control •
<p>4.6 Is the spout outlet no higher than 36 inches above the floor?</p>	<p><input checked="" type="checkbox"/> Yes <input type="checkbox"/> No Measurement:</p> <p>36"</p>		<p>Photo #: 4.6</p>	<ul style="list-style-type: none"> • Adjust drinking fountain • Replace drinking fountain •
<p>4.7 Is the spout:</p> <p>At least 15 inches from the rear of the drinking fountain?</p> <p>No more than 5 inches from the front of the drinking fountain?</p>	<p><input checked="" type="checkbox"/> Yes <input type="checkbox"/> No Measurement:</p> <p>16"</p> <p><input checked="" type="checkbox"/> Yes <input type="checkbox"/> No Measurement:</p> <p>3"</p>		<p>Photo #: 4.7</p>	<ul style="list-style-type: none"> • Adjust spout • Replace drinking fountain •

<p>4.8 If there is more than one drinking fountain, is there at least one for standing persons?</p> <p>Is the spout outlet no lower than 38 inches and no higher than 43 inches above the floor?</p>	<p><input checked="" type="checkbox"/> Yes <input type="checkbox"/> No</p> <p><input checked="" type="checkbox"/> Yes <input type="checkbox"/> No</p> <p>Measurement: 36"</p>		<p>Photo #: 4.8</p>	<ul style="list-style-type: none"> • Adjust drinking fountain • Install new drinking fountain for standing height •
<p>4.9 If the leading (bottom) edge of the fountain is higher than 27 inches above the floor, does the front of the fountain protrude no more than 4 inches into the circulation path?</p>	<p><input type="checkbox"/> Yes <input type="checkbox"/> No</p> <p>Measurement:</p>		<p>Photo #: NA</p>	<ul style="list-style-type: none"> • Adjust drinking fountain • Replace drinking fountain • Add tactile warning such as permanent planter or partial walls
<p>Public Telephones (2010 Standards – 704) TTY's are devices that employ interactive text-based communication through the transmission of coded signals across the telephone network. They are mainly used by people who are deaf and/or cannot speak.</p>				
<p>4.10 Does at least one telephone have a clear floor space at least 30 inches wide x at least 48 inches long for a parallel or forward approach?</p>	<p><input checked="" type="checkbox"/> Yes <input type="checkbox"/> No</p> <p>30" X 48"</p>		<p>Photo #: 4.10</p>	<ul style="list-style-type: none"> • Move telephone • Install new telephone for clear floor space •

<p>4.11 Is the highest operable part of the telephone no higher than 48 inches above the floor?</p>	<p><input type="checkbox"/> Yes <input checked="" type="checkbox"/> No</p> <p>Measurement: 51" TO COIN SLOT</p>		<p>Photo #: 4.10</p>	<ul style="list-style-type: none"> • Adjust telephone • •
<p>4.12 If the leading (bottom) edge of the telephone is higher than 27 inches above the floor, does the front of the telephone protrude no more than 4 inches into the circulation path?</p>	<p><input checked="" type="checkbox"/> Yes <input type="checkbox"/> No</p> <p>Measurement: 32 ½" ABOVE FLOOR 8" DEEP</p>		<p>Photo #: 4.10</p>	<ul style="list-style-type: none"> • Adjust telephone • •
<p>4.13 Does at least one telephone have a volume control?</p>	<p><input type="checkbox"/> Yes <input checked="" type="checkbox"/> No</p>		<p>Photo #: 4.10</p>	<ul style="list-style-type: none"> • Install volume control • Replace telephone with one that has volume control •
<p>4.14 Is the volume control identified by a pictogram of a telephone handset with radiating sound waves?</p>	<p><input type="checkbox"/> Yes <input checked="" type="checkbox"/> No</p>		<p>Photo #: 4.10</p>	<ul style="list-style-type: none"> • Add pictogram • •

<p>4.15 Does at least one telephone have a TTY?</p>	<p><input type="checkbox"/> Yes <input type="checkbox"/> No</p>		<p style="text-align: center;">NA</p> <p>Photo #:</p>	<ul style="list-style-type: none"> • Install TTY • •
<p>4.16 Is the touch surface of the TTY keypad at least 34 inches above the floor?</p>	<p><input type="checkbox"/> Yes <input type="checkbox"/> No</p> <p>Measurement:</p>		<p style="text-align: center;">NA</p> <p>Photo #:</p>	<ul style="list-style-type: none"> • If a seat is provided, TTY is not required to be 34 inches minimum above the floor • Adjust height of TTY •
<p>4.17 Is the TTY identified by the International Symbol of TTY?</p>	<p><input type="checkbox"/> Yes <input type="checkbox"/> No</p>		<p style="text-align: center;">NA</p> <p>Photo #:</p>	<ul style="list-style-type: none"> • Add symbol • •
<p>4.18 Do signs that provide direction to public telephones also provide direction to the TTY?</p>	<p><input type="checkbox"/> Yes <input type="checkbox"/> No</p>		<p style="text-align: center;">NA</p> <p>Photo #:</p>	<ul style="list-style-type: none"> • Add signs • •

<p>4.19 Do telephones that do not have a TTY provide direction to the TTY?</p>	<input type="checkbox"/> Yes <input type="checkbox"/> No	 	<p style="text-align: center;">NA</p> <p>Photo #:</p>	<ul style="list-style-type: none"> • Add signs • •
<p>Fire Alarm Systems (2010 Standards – 702)</p>				
<p>4.20 If there are fire alarm systems, do they have both flashing lights and audible signals?</p>	<input type="checkbox"/> Yes <input type="checkbox"/> No		<p style="text-align: center;">NA</p> <p>Photo #:</p>	<ul style="list-style-type: none"> • Install audible and visual alarms • •
	<input type="checkbox"/> Yes <input type="checkbox"/> No		<p>Photo #:</p>	<ul style="list-style-type: none"> • • •
	<input type="checkbox"/> Yes <input type="checkbox"/> No		<p>Photo #:</p>	<ul style="list-style-type: none"> • • •
	<input type="checkbox"/> Yes <input type="checkbox"/> No		<p>Photo #:</p>	<ul style="list-style-type: none"> • • •

HIDEWOOD NORTH PRIORITY 1



Photo #1.1



Photo #1.2



Photo #1.3



Photo #1.7

HIDEWOOD NORTH PRIORITY 1



Photo #1.13



Photo #1.14



Photo # 1.41



Photo #1.42

HIDEWOOD NORTH PRIORITY 1

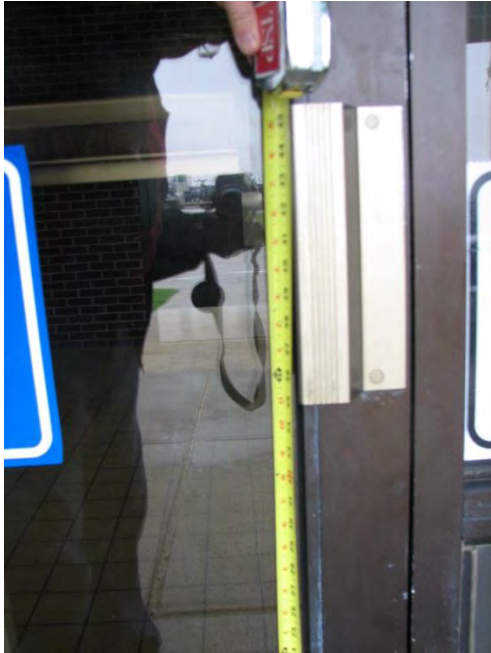


Photo #1.44



Photo # 1.46

HIDEWOOD NORTH PRIORITY 2



Photo #2.1



Photo #2.2



Photo #2.4



Photo #2.8

HIDEWOOD NORTH PRIORITY 2



Photo #2.38



Photo #2.68

HIDEWOOD NORTH PRIORITY 3 – MEN'S



Photo #3.4



Photo #3.6



Photo #3.7

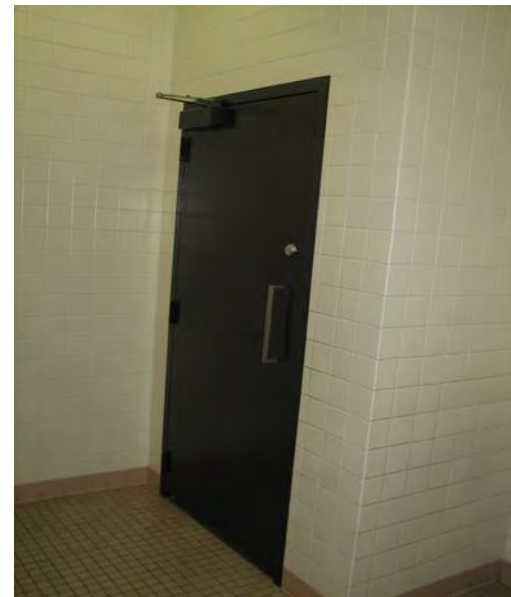


Photo #3.9

HIDEWOOD NORTH PRIORITY 3 – MEN'S



Photo #3.10



Photo # 3.20



Photo # 3.29



Photo # 3.30

HIDEWOOD NORTH PRIORITY 3 – MEN'S



Photo #3.41



Photo #3.42



Photo #3.44

HIDEWOOD NORTH PRIORITY 3 – WOMEN'S



Photo #3.4



Photo #3.6



Photo #3.7



Photo #3.9

HIDEWOOD NORTH PRIORITY 3 – WOMEN'S



Photo #3.10



Photo # 3.20



Photo # 3.28



Photo # 3.29

HIDEWOOD NORTH PRIORITY 3 – WOMEN'S



Photo #3.30



Photo #3.41



Photo #3.46

HIDEWOOD NORTH PRIORITY 4



Photo #4.6



Photo #4.7

HIDEWOOD NORTH PRIORITY 4



Photo #4.8



Photo #4.10



The Interstate Rest Areas Study: Along the I-29 and I-90 Corridors

APPENDIX C AUDITMATE SUMMARY

Detailed Component List for One Facility
HIDE_RAN Hidewood Interstate Rest Area North Bound

09/25/13

Class	Component	Comment	Quantity	Unit Cost	Lifespan	Age	Installed	Renewal Cost (RC)	Deferred Cost (DC)
Site Structures									
	Brick and Cedar Roof Picnic Shelters	Replace Shingles, repair & repaint roofs, clean and inspect masonry	4						
	Reinforced Concrete Picnic Tables		8						
	Information Display (outdoor)	needs cleaning	1						
Exterior Closure									
	Masonry Wall Mortar, Concrete Mortar	Needs tuckpointing							
	Masonry Wall Mortar, Concrete Mortar								
	Steel Double Door								
	Storefront Single door, Metal and Glass								
	Aluminum Frame and Glazing								
	Aluminum Frame and Glazing								
	Paint (trim, soffits)	Soffits need cleaning/paint							
Roofing and Drainage									
	Galvanized Metal Roof, Standing Seam, Factory Finish (entry)	Appears in good condition							
	Wood Shingle Roof	Ready for replacement							
	Wood Shingle Roof	Ready for replacement							
	Downspouts, Galvanized Steel, Factory Finish	fix at grade (grass covers drain ends).							
	Gutters, Galvanized Steel, Hung, Factory Finish								
Interior Construction									
	Ceramic Tile Wall	good condition in general							
	Painting, Interior, Average Grade	Fair condition, faded							
	Ceramic Tile Floor (restrooms 1/2 x 1/2)	Good condition, needs heavy cleaning and minor repairs							
	Quarry Tile Floor 6" x 6" (Lobby)	fair condition, needs heavy cleaning and minor repairs							
	Toilet Stall Door, Metal, Baked Enamel Finish	worn							
	Brick Interior Walls	general cleaning							
	Exposed Wood framing, ceiling	may have leak damage							
Plumbing									
	Tank, Holding Tank, 05000-6000 gallons	There are no reported issues. Suggest periodically testing for bacterial growth in the tanks							
	Water Softening System, Residential	There are no reported issues. Assuring that the water softener is regenerated properly will help to extend the life of the resin. Resin can gel if not periodically and continuously regenerated.							
	Domestic Water Well-Pressure Tank, Medium	Tanks appear to be in good condition			40				

Detailed Component List for One Facility
HIDE_RAN Hidewood Interstate Rest Area North Bound

09/25/13

Class	Component	Comment	Quantity	Unit Cost	Lifespan	Age	Installed	Renewal Cost (RC)	Deferred Cost (DC)
	Domestic Water Pressure Pump	Fully operational. Only preventive maintenance or minor repairs are required.	1 each		40	21	1992		
	Water Cooler, High-LowTwo Level Type	Fully operational. Only preventive maintenance or minor repairs are required.	1 each		40				
	Water Heater, Residential, Commercial, Gas, 051-99 50 Gallons	Appears to be in good condition. Occasionally blowing the bottom out to remove residue and scale may add another 2 years to its life.			10				
	Faucet								
	Lavatory Sink, Set in Countertop Men's Toilet	Fully operational. Packaged, solid surface countertop with integral (3) lavatory bowls. Built-in push button tempered water supply.	1 each		40	21	1992		
	Lavatory Sink, Set in Countertop Women's Toilet	Fully operational. Packaged, solid surface countertop with integral (3) lavatory bowls. Built-in push button tempered water supply.	1 each		40	21	1992		
	Slop Sink, Single Bowl, Enamel	Fully operational. Wall mounted cast iron. Only preventative maintenance or minor repairs are required.	1 each		40	21	1992		
	Urinal, Porcelain, Wall-Hung	Appear to be in good condition for their age. Replacing units with low water consumption units will extend the life of the lagoon.	2 each		40	21	1992		
	Water Closet, Wall-Hung	Replacing units with low water consumption units will extend the life of the lagoon.	6 each	\$720.00	40	21	1992	\$4,320	\$0
	Wall Hydrant	Fully operational. Wall mounted with loose key handle. Only preventive maintenance or minor repairs are required.	1 each		40	21	1992		
	Waste and Vent Piping, above floor	Appears to be in good condition, no apparent leaks. Vent piping is a combination of copper and PVC plastic pipe.			40	21	1992		
	Waste piping - under floor	Fully operational. Waste piping is a combination of cast iron pipe installed in 1980 and PVC plastic pipe installed in 1992			40	33	1980		
	Water Piping	Appears to be in good condition. Copper pipe and fittings			40	21	1992		
	Piping Insulation	Appears to be in good condition. Fabric jacketed pipe insulation.			40	21	1992		
	Valves	Valves appear to be in good condition			40	21	1992		
	Pipe Hangers and Supports	Appears to be in good condition.			40	21	1992		

Detailed Component List for One Facility
HIDE_RAN Hidewood Interstate Rest Area North Bound

09/25/13

Class	Component	Comment	Quantity	Unit Cost	Lifespan	Age	Installed	Renewal Cost (RC)	Deferred Cost (DC)
Mechanical									
	AC Split System Outdoor Condensing, 03-3.5 Ton	Like new with no defects. Only preventive maintenance is required.							
	Furnace - High Efficiency, Propane gas fired	Fully operational. However, unit is beyond its expected service life	2 each		20	21	1992		
	Air Handling Unit, split system AC/Gas heat, 03-3.5 Ton		2 each	\$2,200.00	40	21	1992	\$4,400	\$0
	In-Line Exhaust fan	Units is in good condition. Only preventive maintenance and minor repairs are required.	1 each		25				
	Electric Duct Heater, 027,200 BTU/hr, 08KW 40,000 BTUH, 12.0 KW	Fully operational. However, unit is beyond its expected service life.							
	Space Heater, Gas-Fired, Ceiling-Mounted, 0-100 MBH 24,900 BTUH	Fully operational. However, unit is beyond its expected service life.			20				
	Hydronic Circulating Pump, Base-Mounted, 005 HP								
	Ductwork	Duct appears to be in good condition. No leaks			40	21	1992		
	Ductwork - underfloor	Duct appears to be in good condition.			40	21	1992		
	Duct Insulation	Rigid external duct insulation is in good condition			40	21	1992		
	Temperature Controls	Thermostats for all heating and cooling equipment are in operational condition	4 each		20	21	1992		
Electrical									
	Panelboard, Main Breaker, 3 PH, 208V, 0225-0250A	Fully operational, only preventive maintenance required.				21	1992		
	Panelboard, MLO, 3 PH, 208V, 0225-0250A	Fully operational, only preventive maintenance required.				33	1980		
	Fluorescent Fixture, 1' x 4' T-8	Fully operational, lamps are hard to get and expensive				21	1992		
	Fluorescent Fixture, 1' x 4' , Economy	Fully operational, lamps are hard to get and expensive				21	1992		
	Incandescent Fixture, Surface Mounted, Stock	Fully operational, only preventive maintenance required.			50	21	1992		
	Outdoor fixture, Cobrahead	Fully operational, only preventive maintenance required.							
	Outdoor fixture, HID, Large, Pole-Mounted	Internal wiring in the fixture is deteriorated.							
	Outdoor Fixture, Surface-Mounted, HID, Stock	Fully operational, some lenses show deterioration.							
	Outdoor Fixture, Surface-Mounted, HID, Stock, Small	Fully operational, some lenses show deterioration.				21	1992		
	CCTV Camera w/Cabling	Fully operational, only preventive maintenance required.							
	Electric Hand Dryer	Fully operational, only preventive maintenance required.				21	1992		
	Emergency Beacon - Well Monitoring System	Understand in good condition			40	21	1992		

Detailed Component List for One Facility
HIDE_RAN Hidewood Interstate Rest Area North Bound

09/25/13

Class	Component	Comment	Quantity	Unit Cost	Lifespan	Age	Installed	Renewal Cost (RC)	Deferred Cost (DC)
	Phone Unit	Wall Mount, replace - Non ADA compliant	1 each		20	21	1992		
Utilities									
	U/G Fuel, Steel tank, single Wall Tank		1,000 Gallons	\$11.00	30	21	1992		
	U/G Fuel, Steel tank, single Wall Tank		1,000 Gallons	\$11.00	30	21	1992		
Sanitary Sewer System									
	Lagoons	Both lagoons were relined in 2011 and should not need additional repair in the near future					2011		
	Sewage Piping System	No problems have been reported concerning the sewer pipes and manholes							
Water System (Rural Water)									
	Water Pipe System	System is rural water with meter and UG storage tanks. Tanks were replaced with fiberglass tanks a few years ago so should ne need replacing in the near future. No problems reported concerning the water system.							
Infrastructure									
	Parking Area, Non Reinforced Concrete 9.5"	Most of the concrete pavement is in good shape. There is some curb and gutter (approximately 5%) that should be removed and replaced in the next 5-10 years. There is also a significant amount of corner cracking of concrete panels. Most of these can be repaired and sealed. Approximately 10% of the panels need to be removed and replaced in the next 10 years.							
	Sidewalk, Concrete	Concrete walks generally in good shape. Approximately 15% should be replaced in the next 5-10 years. Mudjacking has been done around the building. If this holds the walks around the building in place, these walks should last in excess of 10 years.							
	Landscaping	Landscaping consists of grass and tree and are in good shape.							
	Wayfinding Signage	Signage is in good shape							
	Site Lighting - Parking	Lights replaced in the mid-1990's. Some problems with the 50' light bases (a washer problem) needs to be addressed.							

Detailed Component List for One Facility
HIDE_RAN Hidewood Interstate Rest Area North Bound

09/25/13

Class	Component	Comment	Quantity	Unit Cost	Lifespan	Age	Installed	Renewal Cost (RC)	Deferred Cost (DC)
	Site Lighting - Pedestrian	Lights replaced in the mid-1990's. No problems indicated							

**HIDEWOOD SOUTHBOUND
REST AREA**

TECHNICAL REVIEW REPORT

Prepared for:

Mr. Brad Remmich
South Dakota Department of Transportation
Office of Project Development
700 East Broadway Avenue
Pierre, SD 57501-2586
(605) 773-3093

Prepared by:

TSP
600 Kansas City Street
Rapid City, SD 57701-2712
(605) 343-6102

Felsburg Holt & Ullevig
6300 South Syracuse Way, Suite 600
Centennial, CO 80111
(303) 721-1440

FHU Reference No. 113039-01
December 2013



The Interstate Rest Areas Study: Along the I-29 and I-90 Corridors

TABLE OF CONTENTS

	<u>Page</u>
I. INTRODUCTION -----	1
II. GENERAL OVERVIEW -----	2
A. Rest Area Layout -----	2
B. Field Visit Observations -----	4
C. User Environment -----	4
D. Existing Building Code Conformity -----	4
E. Americans with Disabilities Act (ADA) Survey -----	5
F. Energy and Water Usage Review -----	6
III. BUILDING SYSTEM OVERVIEW -----	7
A. Architectural System -----	7
B. Plumbing System -----	7
C. Mechanical System -----	7
D. Electrical System -----	8
E. Sanitary Sewer System -----	8
F. Water System -----	8
G. Infrastructure -----	9
IV. SUMMARY -----	10

APPENDIX A MAINTENANCE STAFF MEETING MINUTES

APPENDIX B ADA SURVEY RESULTS

APPENDIX C AUDITMATE SUMMARY

LIST OF FIGURES

	<u>Page</u>
Figure 1. Hiwewood Southbound Rest Area Site Layout -----	3



I. INTRODUCTION

The Hidewood South Rest Area is located along Interstate 29, near the town of Watertown South Dakota. The facility is located approximately 18 miles southeast of Watertown and 28 miles north of Brookings, South Dakota. The rest area has direct access to and from Interstate 29 servicing south bound traffic. The truck parking lot is separated from the public parking lot.

The purpose of this report is to summarize the condition of existing site components and building systems for the facility as a whole. The intent for this report is to define the general status of the existing facilities given their age and use.

The report has been divided into two general areas of focus. The first section includes a general overview of the facility design and operations. Architectural issues, including the general capacity of the facilities and current operations, are reviewed and compared to current facility standards (i.e., building codes, ADA, etc.).

The systems overview section covers the type and condition of the components that make up the facility, and includes a summary evaluation of the site and building infrastructure. The site infrastructure repairs/replacement review includes sidewalks, lighting, signage, landscaping, and picnic shelters. The building systems infrastructure review includes items such as the building shell and structure, mechanical and plumbing systems, electrical, interior finishes, and communications/IT equipment.



II. GENERAL OVERVIEW

A. Rest Area Layout

The developed portion of the site is spacious running north to south paralleling the parking lots and interstate to the west. Entry to the rest area is provided via direct access from I-29. Upon entering, parking lots for passenger vehicles and trucks separated. The main facility is centrally located on the higher end of the properties. It includes a small lobby (with no tourist information center), restrooms and mechanical/utility space to the north and south west of the building are the walking paths and picnic shelters. Roughly 800' to the southwest are two sewage ponds supporting the facility.

Outdoor facilities include:

- Four dual brick picnic shelters (2/ea. reinforced concrete tables/bench sets on concrete slabs) approx. 19'x29', one structure has been expanded to also include vending equipment
- One exterior visitor display structure
- Dumping station
- Flag pole

Utilities Include:

- Rural water with underground tank system and pump
- Gravity sewer system with lagoons (2)
- Underground propane tanks (2)
- Electric power and transformer
- Telephone service

The 1,616 square foot facility includes the following:

- Lobby, and secured visitor center
- Men's and women's restrooms
- Mechanical, maintenance and storage area

Building Systems include:

- Heating and cooling including split system gas heating and electric cooling units
- Service area heating utilizing a gas fired unit heater
- Ventilation is exhaust with make-up air
- Power is single phase, 120/240 volt, 225 amp
- Gas fired storage type water heater
- Water softener

Figure 1 shows the layout of the Hidewood Southbound Rest Area facility including the rest area's location in relation to major roadways in the area.

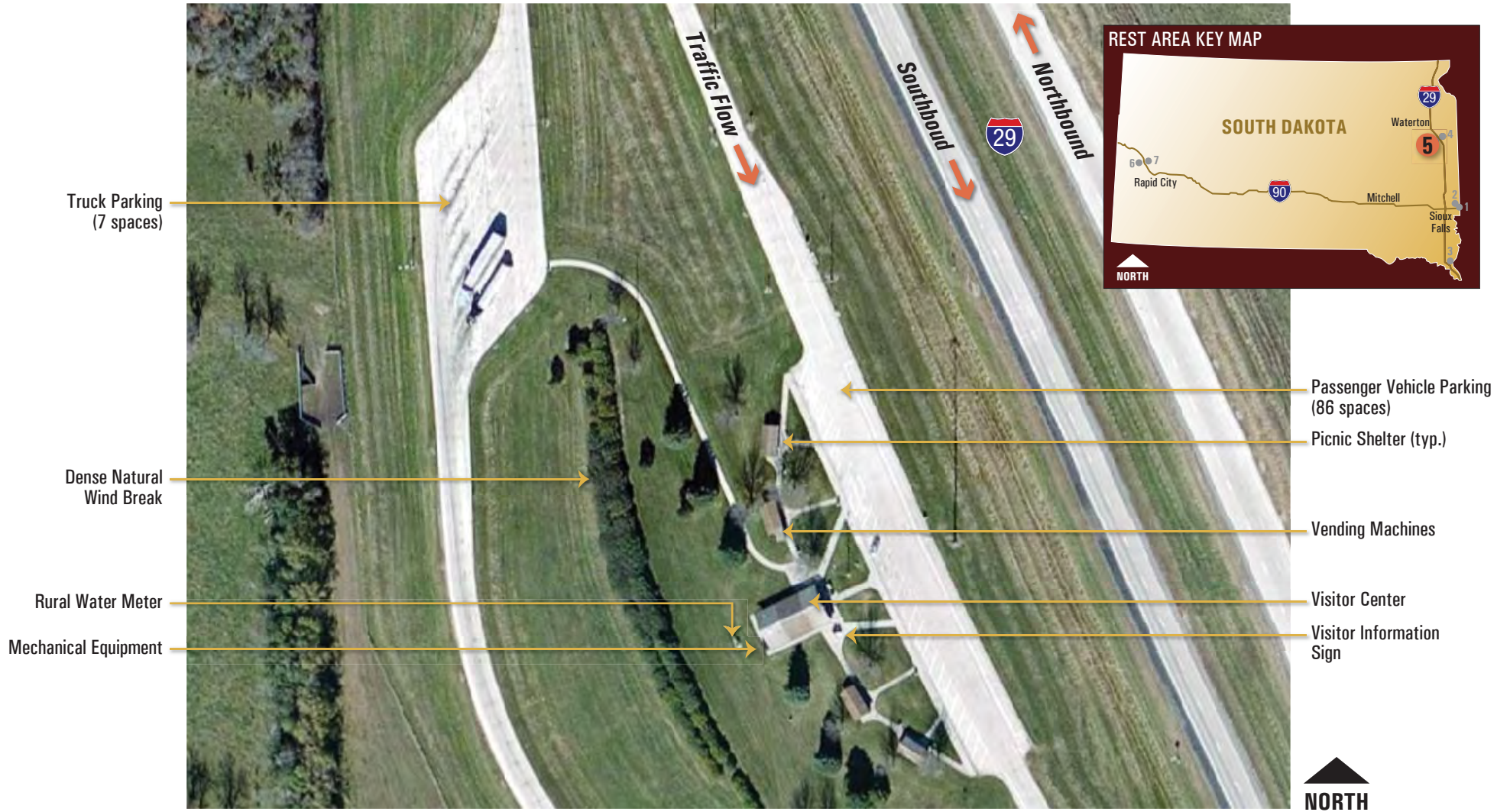


Figure 1. Hidewood Southbound Rest Area Site Layout



B. Field Visit Observations

A field meeting was held with TSP and SDDOT officials on September 17, 2013 to gain initial insights from the SDDOT maintenance team about the operation, history, and condition of the existing on-site facilities at the Rest Area. A copy of the meeting minutes are contained in **Appendix A** in this report and the following summarizes the key points of the meeting:

- The original portion of the facility was designed and constructed in 1980 with an addition to both the front (for lobby space) and rear (mechanical/utility room) in 1992.
- The site has been well maintained, there are some age related repairs required (sidewalks, picnic shelter roofs, etc.) and replacement (lighting, and the sprinkler system).
- The facility shell is in good condition given the age, with the exception of the cedar shingle roof system which is failing. The interiors are in good condition and may require updating, heavy cleaning, refinishing and interior lighting. The existing furnace and support equipment are nearing their design life.
- There have been limited improvements made to the facility to address some ADA requirements, and building codes. In general, the restrooms are small and narrow, with minimal space for circulation. Also, access to the restrooms from the lobby will likely require rework of interior bearing walls to reconfigure entrances. There may be a need to expand the restrooms to accommodate 5' wide toilet facilities, and possibly family rooms.
- The Truck parking lot may need to be expanded and modified to shorten the distance truckers must walk to the facility.

C. User Environment

The facility and site are visible from mainline Interstate 29. Architecturally, the site is inviting as it not too cluttered, and there are very nice views of the open and historic grass lands to the east. The truck parking area is separated from the general public areas and the passenger car lot by a mature and dense windbreak of trees and shrubs. The walk from the truck parking area to the visitor's center is approximately 400 feet. The brick and cedar roofed building and picnic shelters are utilitarian (mostly functional and non-descript), are reaching their design life and in good condition. The interior brick lobbies are open and comfortable. The restrooms are noticeably small and in good shape, and may require additional lighting, heavy cleaning, and improved ventilation.

D. Existing Building Code Conformity

The current facilities were designed and constructed in 1980 and upgraded in 1992, to the codes at the time which lacked consideration for people with disabilities. To quantify the differences in code standards, the existing main building was evaluated per the ICC 2012 International Building Code which has been adopted by the State of South Dakota. Based on the use of the existing facility, the following building classifications were utilized in the comparison:





- Size: 1,616 square feet
- Occupant Type: Mercantile
- Construction Type: Type 3-b (or 5-b)
- Occupant Load: < 50
- Maximum access travel: 75 feet
- Required Exits: 1

The following outline the major areas where the existing building deviates from the requirements of the current Building Code (IBC 2012):

- Facility does not include a family / assisted-use restroom
- Several areas are not ADA compliant per ICC A117.1-2009 (outlined in proceeding sections of this report)

It should be noted that per the “Existing” Building Code, unless there are significant safety hazards, the facilities are not required to be modernized as a whole to meet current code standards. However, any repairs or new additions will need to be completed to these standards. The exception concerns ADA requirements, which are a retroactive federal requirement. When the ADA is addressed the project will need to also be completed per building code, which includes accessibility criteria (ICC- A117.1-2009).

E. Americans with Disabilities Act (ADA) Survey

As stated previously, the building was originally constructed prior to the full implementation of ADA standards. Restrooms have stalls for ambulatory use (3'-4" wide), and gang sinks with electronic sensors. To quantify the improvements required for compliance with current ADA standards, a detailed survey was completed utilizing the “ADA Checklist for Readily Achievable Barrier Removal” per the DOJ ADA Standards for Accessible Design - 2010. The survey identified the following general deficiencies, and more detailed information is referenced in **Appendix B** of this report:

Priority 1 Deficiencies (access to building):

- Accessible parking spaces at the front of the building meet maximum slope limitations and the accessible entrance walk meets ADA requirements
- Parking signs meet current MUTCD and ADA standards with the exception of a Van Accessible sign which is needed for one of the spaces
- ADA pull handle on entrance door has insufficient clearance
- Door closer takes less than 5 seconds to close from and open position

Priority 2 Deficiencies (Access to Goods and Services):

- CCTV Information Area:
 - Displays should be reviewed for accessibility.
 - Signage, upgrade signs to current ADA standards.



Priority 3 (Restrooms):

- Stall doors not self- closing
- The sign on the wall, located on the push side of the door does not meet ADA standards
- There is not adequate clearance on the pull side of the door
- The door hardware is not located in compliance with ADA standards
- The door cannot be opened with 5 lbs. or less of force
- The door does not take more than 5 seconds to close from an open position
- Soap dispensers above the lavatory counter are more than 44 inches above the floor
- Men's and women's toilet does not have adequate clearance to meet ADA standards
- Grab bars do not meet ADA standards
- Toilet paper holders in men's and women's stalls do not meet ASA standards
- Entrance doors to stalls do not meet closure pressure or ADA pull handle standards
- Toilet compartment is less than 60 inches in width

Priority 4 (additional access) Deficiencies:

- Phone is wall mounted and does not meet ADA standards for sound control, TTY plug in, and shelf.

F. Energy and Water Usage Review

TSP has not received any data concerning this information



III. BUILDING SYSTEM OVERVIEW

The following sections include a general review of individual building and site components, starting with site components and then broken down by individual disciplines (Architectural Systems, Mechanical, Electrical, Plumbing, and Civil/Site systems). The discussion generally parallels SDDOT AuditMate database format.

A detailed summary of each discipline section in the current AuditMate format including general comments of individual line items are contained in **Appendix C** of this report. The table contains both existing line items and recommended updates to the SDDOT database, which are shown in **bold** font.

A. Architectural System

The original structure was constructed in 1980. In 1992 the front and rear sections of the building were added on. The building wall system is a reinforced and insulated masonry bearing wall system that also includes interior masonry bearing walls. It has a wood framed roof with cedar shingles on insulation board, on an exposed laminated and painted wood deck. The exterior of the facility is in good shape and could benefit from tuck-pointing and cleaning (as can the picnic shelters). The cedar roof on the facility and the shelters is in poor condition which can damage the framing, walls, and interiors if not addressed. The interior walls, tile work, and ceilings have been well maintained.

B. Plumbing System

Wall hung water closets and wall hung urinals are vitreous china, installed in 1992. Simulated stone, solid surface countertop with integral lavatory sinks were also installed at that time. Water closet and urinal flush valves are push-button manual type, and lavatory faucets are battery operated. A wall hung electric water cooler and drinking fountain outside the building were installed in 1992.

Underground waste and vent piping is cast iron and installed in 1980. Above floor waste and vent piping is a combination of copper and PVC plastic. Above floor copper piping was installed in 1980, while above floor PVC plastic piping was installed later in 1992. Copper water piping and fiberglass insulation with an all service vapor resistant covering was added in 1992.

Water for domestic use is supplied by a rural water system. The system has a water pressure regulator, water meter, backflow preventer, pressure booster pump and a 6000 gallon underground fiberglass holding tank. The system supplies all plumbing fixtures in the building and the lawn irrigation system. There is a water softener for domestic hot and cold water in the building and a gas fired water heater. The water supply system and water softener were installed in 1992, and the gas fired water heater was installed in 2006.

C. Mechanical System

The building is heated and cooled by (2) split-system gas fired furnace with outside air cooled condensing units. The outdoor condensing units were installed in 2008 and the indoor gas fired furnaces in 1992. A gas fired unit heater in the equipment room provides heating to that room. The unit heater was installed in 1992. There are outside air duct connections to both systems



for ventilation. One of the outside air ducts has an electric heater in it to raise the temperature of the outside air before it blends with return air to the gas fired furnace. The electric heater was installed in 1992.

Exhaust ventilation for both toilet rooms is ducted to an in-line fan and out of the building. Exhaust grilles are wall mounted on the water closet wall in each toilet room, and was installed in 1992.

D. Electrical System

The building is served by a 120/240 volt, single phase, 225 amp service. There is a main circuit breaker panel located in the equipment room and a sub-circuit breaker panel located between the toilet rooms. Panels are clearly labeled as to what each CB serves. All wiring is run in conduit. Main circuit breaker panel was installed in 1992, and the sub-circuit breaker panel in 1980.

Lighting fixtures in the building is a mix of surface mounted incandescent and fluorescent fixtures. Indoor lighting fixtures were installed in 1992.

Outdoor lighting is primarily high pressure sodium or HID. Surface mounted fixtures are used on the building. Most outdoor lighting fixtures were installed in 1992.

Hand dryers are electric and operating properly.

CCTV is installed in the lobby. There is also an emergency beacon system, the operation of which was not immediately observable, but confirmed by staff.

Telephone and internet services are installed in the building.

E. Sanitary Sewer System

The sanitary sewer system consists of gravity flow sewer lines to two sewage lagoons located at the south end of the site. The two lagoons are approximately the same size with the south pond acting as an overflow for the north. According to maintenance personnel, the ponds provide adequate capacity.

F. Water System

The water system consists of a rural water connection with meter and an underground tank. No problems were reported with this system.



G. Infrastructure

The parking area is paved with concrete. The general condition of the concrete for the ramps and the parking area is good, with observed deterioration being in the joints. Quite a bit of corner cracking is also evident. The latest pavement rating sheet for this rest area indicates lower scores for joint spalling and joint seal damage but does not indicate a low score for corner cracking. Approximately 5% of the panels will need to be replaced in the near future. Joint and crack repair and sealing should be done as regular maintenance.

Concrete walk extends along the parking spaces, around the building and to picnic shelters located around the site. The majority of the concrete sidewalk is in good shape. Approximately 10% of the sidewalk has cracks that may require replacement in the future. Mudjacking of the walk around the building has been done.



IV. SUMMARY

The Hidewood South Rest Area is located along Interstate 29, near the town of Watertown South Dakota. The facility is located approximately 18 miles southeast of Watertown and 28 north of Brookings, South Dakota. The rest area has direct access to and from Interstate 29 servicing north bound traffic. It also includes a small overlook site and marker.

The purpose of this report was to summarize the condition of existing site components and building systems for the facility as a whole, and to define the general status of the existing facilities given their age and use.

The site is substantial with significant vacant area to allow for expansion in the future. Given that it has been many years (1988) since any major improvements have been made, a refurbishment of the facilities and site components will be required in the years ahead. The facility itself is in average shape and requires immediate repairs. Key repairs will eventually be needed for an upgrade to the heating and ventilating system and the lighting systems.

More importantly, the facility will need to be modified or expanded to comply with ADA/building code requirements. The extent of which has yet to be determined, as an additional factor will be in identifying the added space required to modify the restroom entrances, to support increased user loads (if any), and to provide family assist restroom(s).



The Interstate Rest Areas Study: Along the I-29 and I-90 Corridors

APPENDIX A MAINTENANCE STAFF MEETING MINUTES



October 15, 2013

MEETING MINUTES

SDDOT INTERSTATE REST AREA STUDY

FHU Reference No. 113039-01

Hidewood South Maintenance Review Meeting

Hidewood South Westbound Rest Area

Date of Meeting: September 17, 2013

In attendance:

- Brad Remmich – SDDOT
- Brian Wacholz – SDDOT
- Tim Roach – TSP
- Bob King – TSP
- Todd Schultz - TSP

The purpose of the meeting was to gain initial insights from the SDDOT maintenance team about the operation, history, and condition of the existing on-site facilities at the Hidewood South rest area. The following summarizes the key points of the meeting:

FACILITY USE

- There is a consistent year round use of the facilities by truckers, and local commuters. In the summer, there is increase in tourist use. The facility will likely be impacted by an increase in trucking to and from the North Dakota Oil Fields, and associated population growth.
- Per the SDDOT, at this time the facility seems to be appropriately sized for the current use.
- The facility is limited in interior circulation space for both the restrooms and the visitor's area. The restrooms comfortably support perhaps 3-4 people at a time, but there is little maneuvering space.
- The picnic shelters are used regularly during the summer months (June – August) but are never fully occupied.
- Per the SDDOT, Visitor parking and camper parking is sufficiently sized and the truck parking, which is in a separate lot needs to be expanded and made more accessible.

USER INFORMATION

- There are a fairly balanced proportion of general travelers and truckers at this location. The dumping station is fairly often used, more by locals. Truckers do overnight at this location, most often this facility is an overflow facility when near buy truck stops are full.

FACILITY NEEDS / ISSUES

- There have been some consistent complaints at this location which include:
 - Poor lighting in restrooms.

October 15, 2013

Hidewood South Maintenance Review Meeting

Page 2

- No Family bathrooms provided.
- Expanded parking.

- There has been no urgent safety or security issues reported. The installation of a video monitor system has been very successful in reducing vandalism and security problems. The system is old and only a few of the cameras are in working order. Adding a viewing monitor in the lobby may improve awareness of security.

- There is no known history of accidents related to current facility and on site circulation.

- Site Systems (landscaping, lighting, trash, ponds, etc.):
 - Sidewalk, stairs, and paving show signs of aging and wear, but otherwise surfaces are in good condition.
 - Lagoon System was re-lined and rippapped in 2011. No complaints about the piping system to the lagoon at this time.
 - Rural water supply system and infrastructure in good shape with new fiberglass storage tank. No issues with piping and pumps.
 - The lawn sprinkler system will need replacement.
 - Propane tanks system in good shape, there are two underground tanks.
 - Site drainage is excellent, and there isn't a history of ponding or flooding.
 - Dog walk area has heavy use, could use baggie stand to assist and encourage user pick up and disposal of dog waste.

- Building Systems (shell, interior finishes, MEP):
 - Upgrade to ADA.
 - Replace video camera system.
 - Replace aged water closet and urinal manual flush valves with sensor type or ADA compliant manual flush valves.
 - Replace cedar shingle roof system on main building and picnic shelters.
 - Heat, Cooling, and Ventilation system is in good condition, approximately 5 years old.
 - Electrical power seems to be adequate for the connected loads. Power system may need to be upgraded for any future additional electrical loads.
 - Interior Lighting is adequate – maintenance cost for lamps may justify replacement of fixtures.
 - Bathroom exhaust and make-up air system is adequate.
 - Heating, cooling, and ventilation are adequate at this facility.
 - Domestic water heater, gas fired storage type, is adequate.
 - Water softener system is adequate.

SDDOT MAINTENANCE STAFF REQUESTS

- No additional requests have been discussed.

These meeting minutes were prepared by Tim Roach (TSP). Please contact me at roachtj@teamtsp.com or 605-343-6102 for corrections or clarifications.



The Interstate Rest Areas Study: Along the I-29 and I-90 Corridors

APPENDIX B ADA SURVEY RESULTS

SDDOT Rest Area Improvements
FHU Reference Number 13-039-01
TSP Project Number 03120855

Building **HIDEWOOD SOUTH**

Location **29 S., MRM 160**

Date **09-17-2013 (Inspection)**

ADA Checklist for Readily Achievable Barrier Removal

Priority 1 – Approach & Entrance

SDDOT Rest Area Improvements

FHU Reference Number 13-039-01

TSP Project Number 03120855

Project

Building

HIDEWOOD SOUTH

Location

29 S., MRM 160

Date

09-17-2013 (Inspection)

Surveyors

Timothy Roach, AIA

Todd Schultz, PE

Robert King, CPD

Contact Information

TSP (605) 343-6102



An accessible route from site arrival points and an accessible entrance should be provided for everyone.



Institute for Human Centered Design
www.HumanCenteredDesign.org

November 2011



ADA National Network

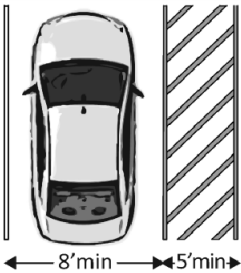
Questions on the ADA 800-949-4232 voice/tty

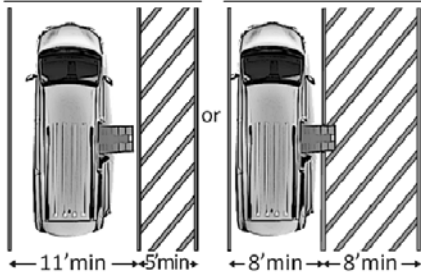
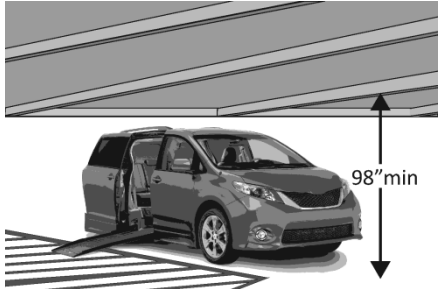
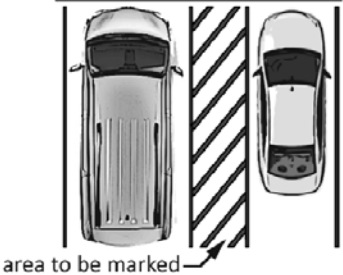
www.ADAchecklist.org


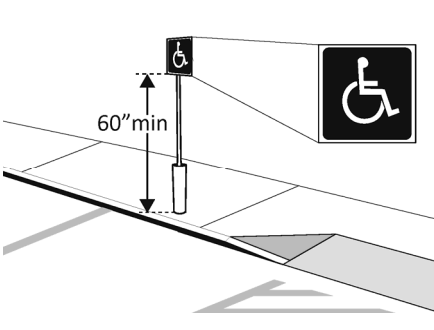

This checklist was produced by the New England ADA Center, a project of the Institute for Human Centered Design and a member of the ADA National Network. This checklist was developed under a grant from the Department of Education, NIDRR grant number H133A060092-09A. However the contents do not necessarily represent the policy of the Department of Education, and you should not assume endorsement by the Federal Government.

Questions or comments on the checklist contact the New England ADA Center at 617-695-0085 voice/tty or ADAinfo@NewEnglandADA.org

For the full set of checklists, including the checklists for recreation facilities visit www.ADAchecklist.org.

Priority 1 – Approach & Entrance		Comments	Possible Solutions												
<p>1.1 Is there at least one route from site arrival points (parking, passenger loading zones, public sidewalks and public transportation stops) that does not require the use of stairs?</p>	<p><input checked="" type="checkbox"/> Yes <input type="checkbox"/> No</p> <p>If yes, location of route:</p>	<p>Photo #: 1.1</p>	<ul style="list-style-type: none"> • Add a ramp • Regrade to 1:20 maximum slope • Add a lift if site constraints prevent other solutions 												
<p>Parking (2010 Standards – 208 & 502) Note: Accessible parking spaces should be identified by size, access aisle and signage.</p>															
<p>1.2 If parking is provided for the public, are an adequate number of accessible spaces provided?</p>	<p><input checked="" type="checkbox"/> Yes <input type="checkbox"/> No</p> <p>Total #: 24</p> <p>Accessible #: 2</p>	<table border="1"> <thead> <tr> <th>Total Spaces</th> <th>Accessible Spaces</th> </tr> </thead> <tbody> <tr> <td>1 - 25</td> <td>1</td> </tr> <tr> <td>26 - 50</td> <td>2</td> </tr> <tr> <td>51 - 75</td> <td>3</td> </tr> <tr> <td>76 - 100</td> <td>4</td> </tr> <tr> <td colspan="2">100+ see 2010 Standards 208.2</td> </tr> </tbody> </table> <p>Photo #: 1.1</p>	Total Spaces	Accessible Spaces	1 - 25	1	26 - 50	2	51 - 75	3	76 - 100	4	100+ see 2010 Standards 208.2		<ul style="list-style-type: none"> • Reconfigure by repainting lines • •
Total Spaces	Accessible Spaces														
1 - 25	1														
26 - 50	2														
51 - 75	3														
76 - 100	4														
100+ see 2010 Standards 208.2															
<p>1.3 Of the accessible spaces, is at least one a van accessible space?*</p>	<p><input type="checkbox"/> Yes <input checked="" type="checkbox"/> No</p>	<p>*For every 6 or fraction of 6 parking spaces required by the table above, at least 1 should be a van accessible space.</p> <p>Photo #: 1.1</p>	<p>* If constructed before 3/15/2012, parking is compliant if at least 1 in every 8 accessible spaces is van accessible</p> <ul style="list-style-type: none"> • Reconfigure by repainting lines 												
<p>1.4 Are accessible spaces at least 8 feet wide with an access aisle at least 5 feet wide?</p>	<p><input checked="" type="checkbox"/> Yes <input type="checkbox"/> No</p> <p>Measurement: 8 FT SPACE 8 FT AISLE</p>	 <p>Photo #: 1.1</p>	<ul style="list-style-type: none"> • Reconfigure by repainting lines <p>Two spaces can share an access aisle (check state requirements; some states, such as Connecticut, require an access aisle for each space)</p>												

<p>1.5 Is the van accessible space:</p> <p>At least 11 feet wide with an access aisle at least 5 feet wide? Or At least 8 feet wide with an access aisle at least 8 feet wide?</p>	<p><input type="checkbox"/> Yes <input type="checkbox"/> No</p> <p>Measurement:</p> <p><input type="checkbox"/> Yes <input type="checkbox"/> No</p> <p>Measurement:</p>		<p>SPACE IS THERE, IT JUST ISN'T SIGNED AS VAN ACCESSIBLE</p> <p>Photo #:</p>	<ul style="list-style-type: none"> • Reconfigure to provide van-accessible space(s) • •
<p>1.6 Is at least 98 inches of vertical clearance provided for the van accessible space?</p>	<p><input type="checkbox"/> Yes <input type="checkbox"/> No</p> <p>Measurement:</p>		<p>NA – SPACE IS THERE, IT JUST ISN'T SIGNED AS VAN ACCESSIBLE</p> <p>Photo #:</p>	<ul style="list-style-type: none"> • Reconfigure to provide van-accessible space(s) • •
<p>1.7 Are the access aisles marked so as to discourage parking in them?</p>	<p><input checked="" type="checkbox"/> Yes <input type="checkbox"/> No</p>		<p>Photo #: 1.1</p>	<ul style="list-style-type: none"> • Mark access aisles • • <p>The marking method and color may be addressed by state/local requirements</p>
<p>1.8 Is the slope of the accessible parking spaces and access aisles no steeper than 1:48 in all directions?</p>	<p><input checked="" type="checkbox"/> Yes <input type="checkbox"/> No</p> <p>Measurement:</p> <p><2%</p>		<p>Photo #:</p>	<ul style="list-style-type: none"> • Regrade surface • •

<p>1.9 Do the access aisles adjoin an accessible route?</p>	<p><input checked="" type="checkbox"/> Yes <input type="checkbox"/> No</p>		<p>Photo #:</p>	<ul style="list-style-type: none"> • Create accessible route • Relocate accessible space •
<p>1.10 Are accessible spaces Identified with a sign that includes the International Symbol of Accessibility? Is the bottom of the sign at least 60 inches above the ground?</p>	<p><input checked="" type="checkbox"/> Yes <input type="checkbox"/> No <input checked="" type="checkbox"/> Yes <input type="checkbox"/> No Measurement: 70"</p>		<p>Photo #: 1.10</p>	<ul style="list-style-type: none"> • Install signs • • <p>The International Symbol of Accessibility is not required on the ground by the 2010 Standards</p>
<p>1.11 Are there signs reading “van accessible” at van accessible spaces?</p>	<p><input type="checkbox"/> Yes <input type="checkbox"/> No</p>		<p>NA – NO SIGN – NEED TO SIGN ONE SPACE</p> <p>Photo #:</p>	<ul style="list-style-type: none"> • Install signs • •
<p>1.12 Of the total parking spaces, are the accessible spaces located on the closest accessible route to the accessible entrance(s)?</p>	<p><input type="checkbox"/> Yes <input checked="" type="checkbox"/> No</p>		<p>CLOSEST ROUTE IS SLIGHTLY STEEPER THAN 5%</p> <p>Photo #: 1.1</p>	<ul style="list-style-type: none"> • Reconfigure spaces • • <p>If parking lot serves multiple entrances, accessible parking should be dispersed</p>

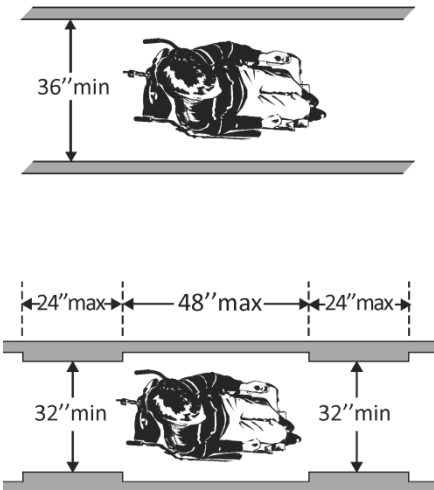
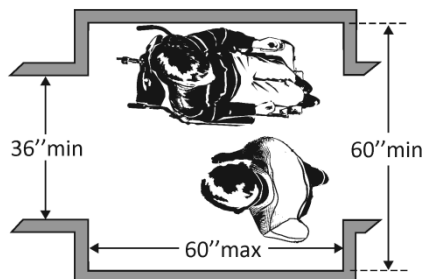
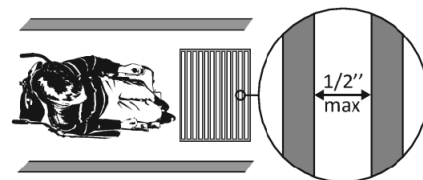
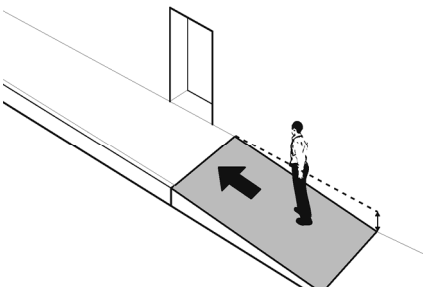
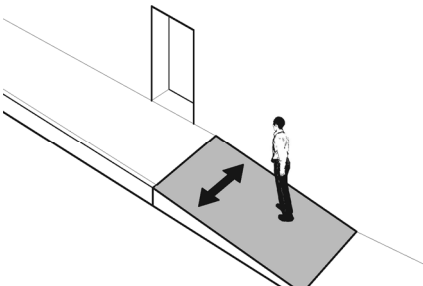
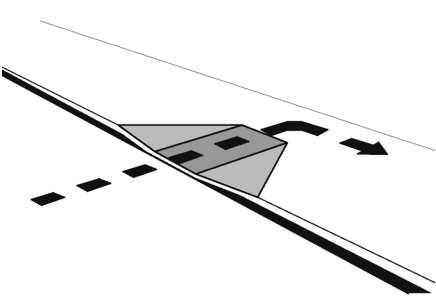
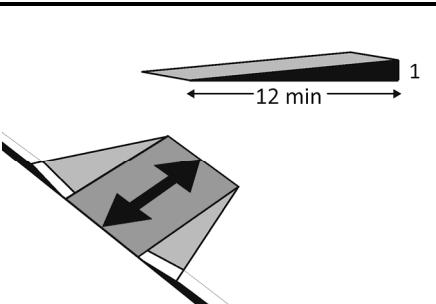
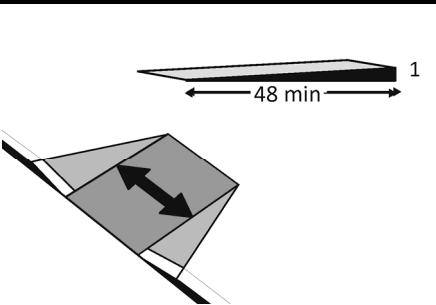
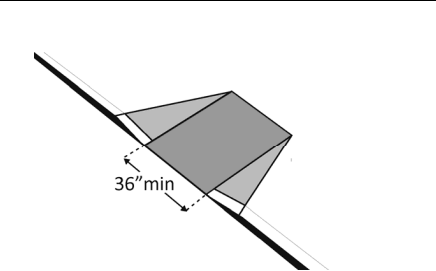
Exterior Accessible Route (2010 Standards – Ch.4)				
<p>1.13 Is the route stable, firm and slip-resistant?</p>	<p><input checked="" type="checkbox"/> Yes <input type="checkbox"/> No</p>		<p>Photo #: 1.13</p>	<ul style="list-style-type: none"> • Repair uneven paving • Fill small bumps and breaks with patches • Replace gravel with asphalt or other surface
<p>1.14 Is the route at least 36 inches wide?</p> <p>Note: The accessible route can narrow to 32 inches min. for a max. of 24 inches. These narrower portions of the route must be at least 48 inches from each other.</p>	<p><input checked="" type="checkbox"/> Yes <input type="checkbox"/> No</p> <p>Measurement: 70"</p>		<p>Photo #: 1.13</p>	<ul style="list-style-type: none"> • Change or move landscaping, furnishings or other items • Widen route •
<p>1.15 If the route is greater than 200 feet in length and no less than 60 inches wide, is there a passing space no less than 60 x 60 inches?</p>	<p><input type="checkbox"/> Yes <input type="checkbox"/> No</p> <p>Measurement: NA</p>		<p>NA</p>	<ul style="list-style-type: none"> • Widen route for passing space • •

			Photo #:	
<p>1.16 If there are grates or openings on the route, are the openings no larger than ½ inches to the dominant direction of travel?</p> <p>Is the long dimension perpendicular to the dominant direction of travel?</p>	<p><input type="checkbox"/> Yes <input checked="" type="checkbox"/> No</p> <p>Measurement:</p> <p><input type="checkbox"/> Yes <input type="checkbox"/> No</p> <p>NA</p>		Photo #:	<ul style="list-style-type: none"> • Replace or move grate • •
<p>1.17 Is the running slope no steeper than 1:20, i.e. for every inch of height change there are at least 20 inches of route run?</p>	<p><input checked="" type="checkbox"/> Yes <input type="checkbox"/> No</p> <p>Measurement:</p> <p><5%</p>		Photo #:	<ul style="list-style-type: none"> • Regrade to 1:20 max. • If steeper than 1:20 and no steeper than 1:12, treat as a ramp and add other features such as edge protection and handrails •
<p>1.18 Is the cross slope no steeper than 1:48?</p>	<p><input checked="" type="checkbox"/> Yes <input type="checkbox"/> No</p> <p>Measurement:</p> <p><2%</p>		Photo #:	<ul style="list-style-type: none"> • Regrade to 1:48 max. • •

Curb Ramps (2010 Standards – 406)

<p>1.19 If the accessible route crosses a curb, is there a curb ramp?</p>	<p><input checked="" type="checkbox"/> Yes <input type="checkbox"/> No</p>		<p>Photo #:</p>	<ul style="list-style-type: none"> • Install curb ramp • •
<p>1.20 Is the running slope of the curb ramp no steeper than 1:12, i.e. for every inch of height change there are at least 12 inches of curb ramp run?</p>	<p><input checked="" type="checkbox"/> Yes <input type="checkbox"/> No</p> <p>Measurement: <1:12</p>		<p>Photo #:</p>	<ul style="list-style-type: none"> • Regrade curb ramp • •
<p>1.21 Is the cross slope of the curb ramp, excluding flares, no steeper than 1:48?</p>	<p><input checked="" type="checkbox"/> Yes <input type="checkbox"/> No</p> <p>Measurement: <2%</p>		<p>Photo #:</p>	<ul style="list-style-type: none"> • Regrade curb ramp • •
<p>1.22 Is the curb ramp, excluding flares, at least 36 inches wide?</p>	<p><input checked="" type="checkbox"/> Yes <input type="checkbox"/> No</p> <p>Measurement: >36"</p>		<p>Photo #:</p>	<ul style="list-style-type: none"> • Widen curb ramp • •

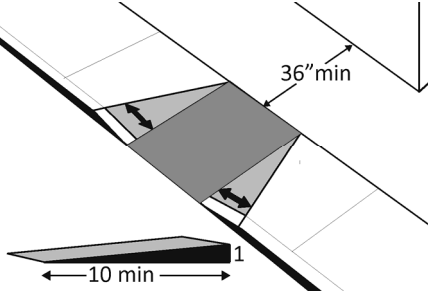
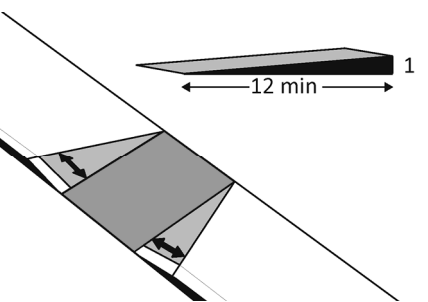
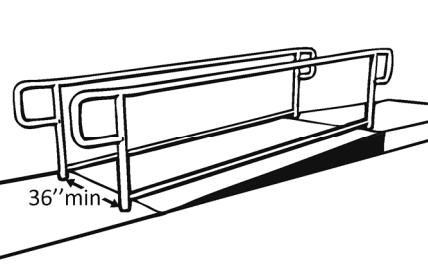
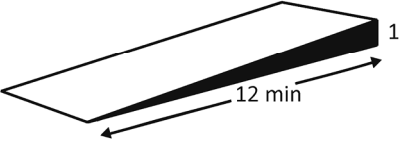
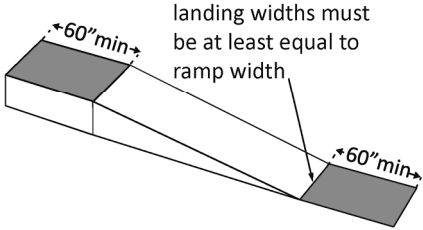
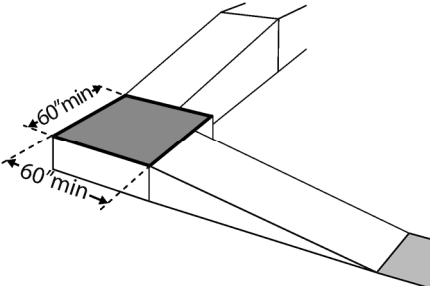
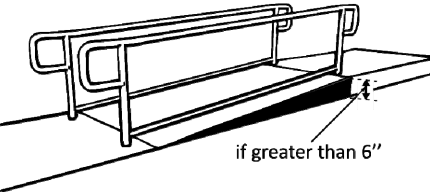
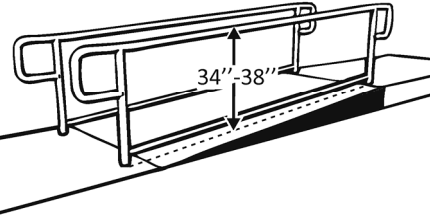
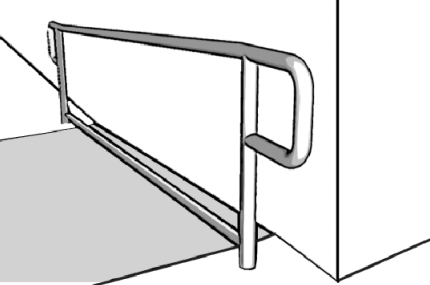
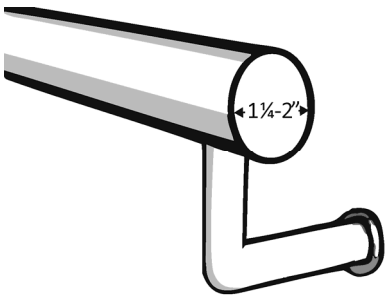
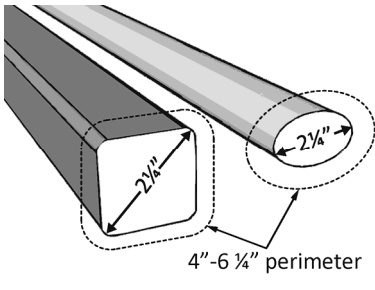
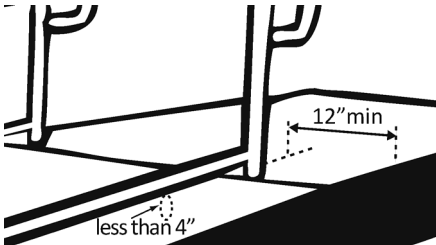
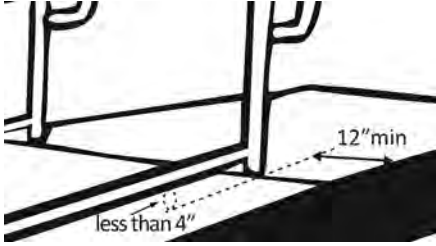



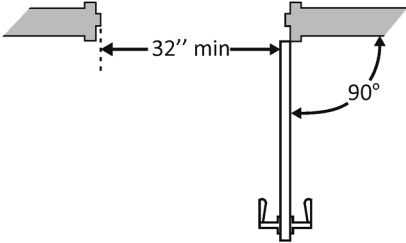
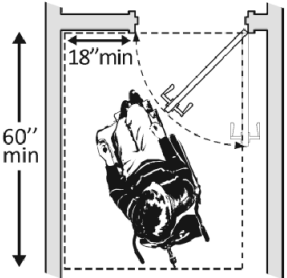
<p>1.23 At the top of the curb ramp is there a level landing (slope no steeper than 1:48 in all directions) that is at least 36 inches long and at least as wide as the curb ramp? If there are curb ramp flares, are the slopes of the flares no steeper than 1:10, i.e. for every inch of height change there are at least 10 inches of flare run?</p>	<p><input checked="" type="checkbox"/> Yes <input type="checkbox"/> No Measurement: <2%</p> <p><input checked="" type="checkbox"/> Yes <input type="checkbox"/> No Measurement: <1:10</p>		<p>Photo #:</p>	<ul style="list-style-type: none"> • Reconfigure • Add ramp flares •
<p>1.24 If the landing at the top is less than 36 inches long, are there curb ramp flares? Are the slopes of the flares no greater than 1:12, i.e. for every inch of height change there are at least 12 inches of flare run?</p>	<p><input type="checkbox"/> Yes <input type="checkbox"/> No <input type="checkbox"/> Yes <input type="checkbox"/> No Measurement:</p>		<p>Photo #:</p> <p style="text-align: center;">NA</p>	<ul style="list-style-type: none"> • Add ramp flares • Regrade flares •
<p>Ramps (2010 Standards – 405 & 505) Note: If any portion of the accessible route is steeper than 1:20, it should be treated as a ramp.</p>				
<p>1.25 If there is a ramp (other than curb ramps), is it at least 36 inches wide? If there are handrails, measure between the handrails.</p>	<p><input type="checkbox"/> Yes <input type="checkbox"/> No Measurement: NA</p>		<p>Photo #:</p> <p style="text-align: center;">NA</p>	<ul style="list-style-type: none"> • Alter ramp • •
<p>1.26 Is the surface stable, firm and slip resistant?</p>	<p><input type="checkbox"/> Yes <input type="checkbox"/> No NA</p>		<p style="text-align: center;">NA</p>	<ul style="list-style-type: none"> • Resurface ramp • •

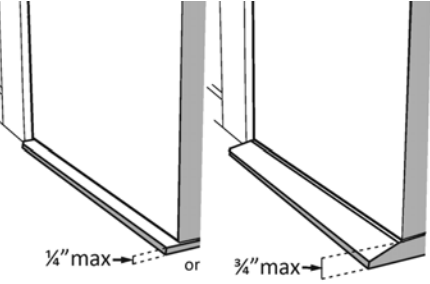
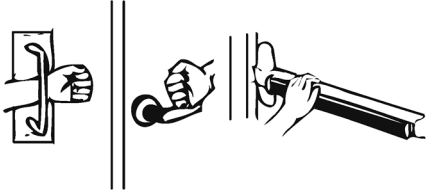
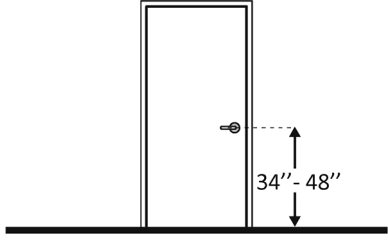
			Photo #:	
<p>1.27 For each section of the ramp, is the running slope no greater than 1:12, i.e. for every inch of height change there are at least 12 inches of ramp run? Note: Rises no greater than 3 inches with a slope no steeper than 1:8 and rises no greater than 6 inches with a slope no steeper than 1:10 are permitted when such slopes are necessary due to space limitations.</p>	<p><input type="checkbox"/> Yes <input type="checkbox"/> No Measurement: NA</p>		<p>NA</p> <p>Photo #:</p>	<ul style="list-style-type: none"> • Alter or relocate ramp • Lengthen ramp to decrease slope •
<p>1.28 Is there a level landing that is at least 60 inches long and at least as wide as the ramp: At the top of the ramp? At the bottom of the ramp?</p>	<p><input type="checkbox"/> Yes <input type="checkbox"/> No Measurement: <input type="checkbox"/> Yes <input type="checkbox"/> No Measurement:</p>		<p>NA</p> <p>Photo #:</p>	<ul style="list-style-type: none"> • Alter ramp • •

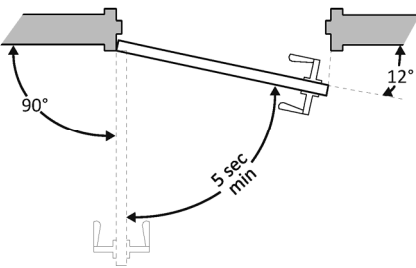
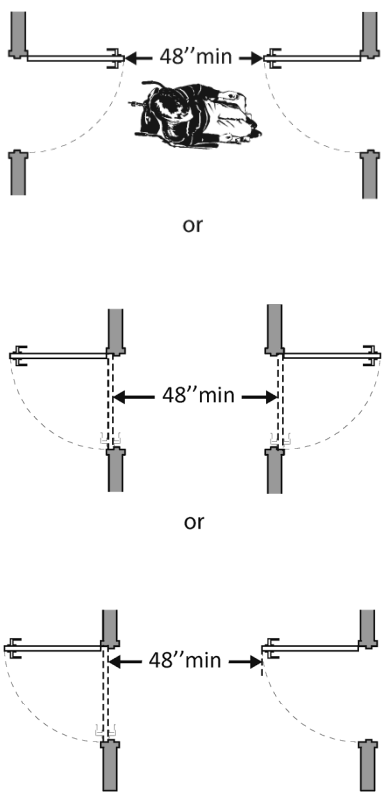
<p>1.29 Is there a level landing where the ramp changes direction that is at least 60 x 60 inches?</p>	<p><input type="checkbox"/> Yes <input type="checkbox"/> No</p> <p>Measurement:</p>		<p style="text-align: center;">NA</p> <p>Photo #:</p>	<ul style="list-style-type: none"> • Alter ramp • •
<p>1.30 If the ramp has a rise higher than 6 inches, are there handrails on both sides?</p>	<p><input type="checkbox"/> Yes <input type="checkbox"/> No</p> <p>Measurement:</p>		<p style="text-align: center;">NA</p> <p>Photo #:</p>	<ul style="list-style-type: none"> • Add handrails • • <p>Curb ramps are not required to have handrails</p>
<p>1.31 Is the top of the handrail gripping surface no less than 34 inches and no greater than 38 inches above the ramp surface?</p>	<p><input type="checkbox"/> Yes <input type="checkbox"/> No</p> <p>Measurement:</p>		<p style="text-align: center;">NA</p> <p>Photo #:</p>	<ul style="list-style-type: none"> • Reconfigure or replace handrails • •
<p>1.32 Is the handrail gripping surface continuous and not obstructed along the top or sides?</p> <p>Is the bottom of the handrail gripping surface obstructed for no more than 20 percent of its length?</p>	<p><input type="checkbox"/> Yes <input type="checkbox"/> No</p> <p><input type="checkbox"/> Yes <input type="checkbox"/> No</p> <p>Measurement:</p>		<p style="text-align: center;">NA</p> <p>Photo #:</p>	<ul style="list-style-type: none"> • Reconfigure or replace handrails • •


<p>1.33 If the handrail gripping surface is circular, is it no less than 1 ¼ inches and no greater than 2 inches in diameter?</p>	<p><input type="checkbox"/> Yes <input type="checkbox"/> No</p> <p>Measurement:</p>		<p style="text-align: center;">NA</p> <p>Photo #:</p>	<ul style="list-style-type: none"> • Replace handrails • •
<p>1.34 If the handrail gripping surface is non-circular, is it no less than 4 inches and no greater than 6 ½ inches in perimeter and no more than 2 ¼ inches in cross section?</p>	<p><input type="checkbox"/> Yes <input type="checkbox"/> No</p> <p>Measurement:</p>		<p style="text-align: center;">NA</p> <p>Photo #:</p>	<ul style="list-style-type: none"> • Replace handrails • •
<p>1.35 Does the handrail:</p> <p>Extend at least 12 inches horizontally beyond the top and bottom of the ramp?</p> <p>Return to a wall, guard, or landing surface?</p>	<p><input type="checkbox"/> Yes <input type="checkbox"/> No</p> <p>Measurement:</p> <p><input type="checkbox"/> Yes <input type="checkbox"/> No</p>		<p style="text-align: center;">NA</p> <p>Photo #:</p>	<ul style="list-style-type: none"> • Add extensions • Reconfigure handrails •
<p>1.36 To prevent wheelchair casters and crutch tips from falling off:</p> <p>Does the surface of the ramp extend at least 12 inches beyond the inside face of the handrail?</p> <p>Or</p> <p>Is there a curb or barrier that</p>	<p><input type="checkbox"/> Yes <input type="checkbox"/> No</p> <p>Measurement:</p> <p><input type="checkbox"/> Yes <input type="checkbox"/> No</p>		<p style="text-align: center;">NA</p> <p>Photo #:</p>	<ul style="list-style-type: none"> • Add curb • Add barrier • Extend ramp width •

<p>prevents the passage of a 4-inch diameter sphere?</p>	<p>Measurement:</p>		<p>Photo #:</p>	
<p>Entrance (2010 Standards – 404)</p>				
<p>1.37 Is the main entrance accessible?</p>	<p><input checked="" type="checkbox"/> Yes <input type="checkbox"/> No</p>		<p>Photo #:</p>	<ul style="list-style-type: none"> • Redesign to make it accessible • •
<p>1.38 If the main entrance is not accessible, is there an alternative accessible entrance?</p> <p>Can the alternative accessible entrance be used independently and during the same hours as the main entrance?</p>	<p><input type="checkbox"/> Yes <input type="checkbox"/> No</p> <p><input type="checkbox"/> Yes <input type="checkbox"/> No</p>		<p style="text-align: center; color: red;">NA</p> <p>Photo #:</p>	<ul style="list-style-type: none"> • Designate an entrance and make it accessible • Ensure that accessible entrance can be used independently and during the same hours as the main entrance •

<p>1.39 Do all inaccessible entrances have signs indicating the location of the nearest accessible entrance?</p>	<p><input type="checkbox"/> Yes <input type="checkbox"/> No</p>		<p style="text-align: center;">NA</p> <p>Photo #:</p>	<ul style="list-style-type: none"> • Install signs • Install signs on route before people get to inaccessible entrances so that people do not have to turn around and retrace route •
<p>1.40 If not all entrances are accessible, is there a sign at the accessible entrance with the International Symbol of Accessibility?</p>	<p><input type="checkbox"/> Yes <input type="checkbox"/> No</p>		<p style="text-align: center;">NA</p> <p>Photo #:</p>	<ul style="list-style-type: none"> • Install sign • •
<p>1.41 Is the clear opening width of the accessible entrance door at least 32 inches, between the face of the door and the stop, when the door is open 90 degrees?</p>	<p><input checked="" type="checkbox"/> Yes <input type="checkbox"/> No</p> <p>Measurement:</p> <p style="text-align: center;">34"</p>		<p>Photo #: 1.41</p>	<ul style="list-style-type: none"> • Alter door • Install offset hinges •
<p>1.42 If there is a front approach to the pull side of the door, is there at least 18 inches of maneuvering clearance beyond the latch side plus at least 60 inches clear depth?</p> <p>On both sides of the door, is the</p>	<p><input checked="" type="checkbox"/> Yes <input type="checkbox"/> No</p> <p>Measurement:</p> <p style="text-align: center;">42"</p> <p><input checked="" type="checkbox"/> Yes <input type="checkbox"/> No</p>		<p>Photo #:</p>	<p>See 2010 Standards 404.2.4 for maneuvering clearance requirements on the push side of the door and side approaches to the pull side of the door</p> <ul style="list-style-type: none"> • Remove obstructions

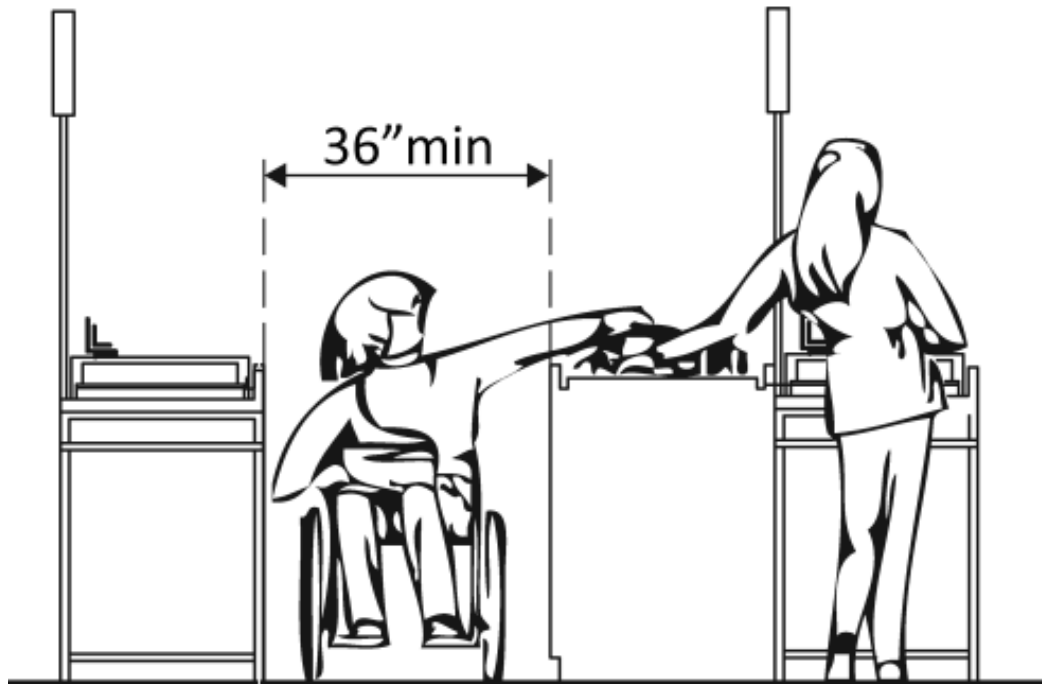
<p>ground or floor surface of the maneuvering clearance level (no steeper than 1:48)?</p>	<p>Measurement:</p>		<p>Photo #: 1.42</p>	<ul style="list-style-type: none"> • Reconfigure walls • Add automatic door opener
<p>1.43 Is the door threshold edge no more than ¼ inch high?</p> <p>Or</p> <p>No more than ¾ inch high if slope is beveled no steeper than 1:2?</p> <p>Note: The first ¼ inch of the threshold may be vertical; the rest must be beveled.</p>	<p><input checked="" type="checkbox"/> Yes <input type="checkbox"/> No</p> <p>Measurement: ¾"</p> <p><input checked="" type="checkbox"/> Yes <input type="checkbox"/> No</p> <p>Measurement:</p>		<p>Photo #: 1.41</p>	<ul style="list-style-type: none"> • Remove or replace threshold • •
<p>1.44 Is the door equipped with hardware, including locks, that is operable with one hand and does not require tight grasping, pinching, or twisting of the wrist?</p>	<p><input type="checkbox"/> Yes <input checked="" type="checkbox"/> No</p>		<p>Photo #: 1.42</p>	<ul style="list-style-type: none"> • Replace inaccessible knob with lever, loop or push hardware • Add automatic door opener •
<p>1.45 Are the operable parts of the door hardware no less than 34 inches and no greater than 48 inches above the floor or ground surface?</p>	<p><input type="checkbox"/> Yes <input checked="" type="checkbox"/> No</p> <p>Measurement: 35" – 45"</p>		<p>Photo #: 1.45</p>	<ul style="list-style-type: none"> • Change hardware height • •

<p>1.46 If the door has a closer, does it take at least 5 seconds to close from an open position of 90 degrees to a position of 12 degrees from the latch?</p>	<p><input type="checkbox"/> Yes <input checked="" type="checkbox"/> No</p> <p>Measurement: 3 SEC.</p>		<p>Photo #: 1.46</p>	<ul style="list-style-type: none"> • Adjust closer • •
<p>1.47 If there are two doors in a series, e.g. vestibule, is the distance between the doors at least 48 inches plus the width of the doors when swinging into the space?</p>	<p><input type="checkbox"/> Yes <input type="checkbox"/> No</p> <p>Measurement:</p>		<p>Photo #:</p>	<p>NA</p> <ul style="list-style-type: none"> • Remove inner door • Change door swing •

<p>1.48 If provided at the building entrance, are carpets or mats no higher than ½ inch thick?</p>	<p><input type="checkbox"/> Yes <input type="checkbox"/> No</p> <p>Measurement:</p>		<p style="text-align: center;">NA</p> <p>Photo #:</p>	<ul style="list-style-type: none"> • Replace or remove mats • •
<p>1.49 Are edges of carpets or mats securely attached to minimize tripping hazards?</p>	<p><input type="checkbox"/> Yes <input type="checkbox"/> No</p>		<p style="text-align: center;">NA</p> <p>Photo #:</p>	<ul style="list-style-type: none"> • Secure carpeting or mats at edges • •

ADA Checklist for Readily Achievable Barrier Removal

Priority 2 – Access to Goods & Services



Project **SDDOT Rest Area Improvements**
FHU Reference Number 13-039-01
TSP Project Number 03120855

Building **HIDEWOOD SOUTH**

Location **29 S., MRM 160**

Date **09-17-2013 (Inspection)**

Surveyors **Timothy Roach, AIA**
Todd Schultz, PE

Robert King, CPD

Contact Information **TSP – (605) 343-6102**

The layout of the building should allow people with disabilities to obtain goods and services and to participate in activities without assistance.



Institute for Human Centered Design
www.HumanCenteredDesign.org

November 2011



ADA National Network
Questions on the ADA 800-949-4232 voice/tty

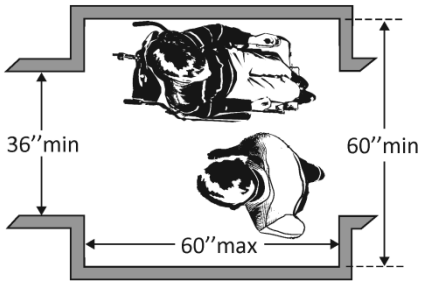
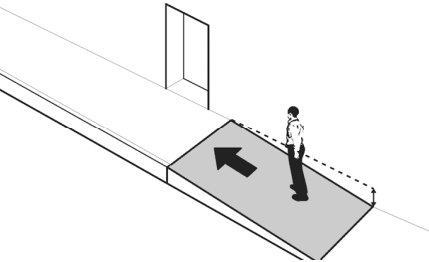
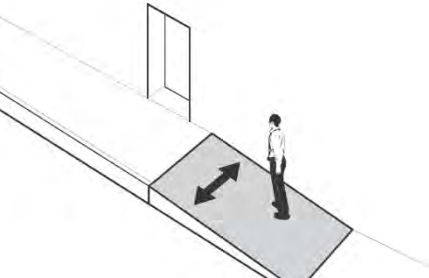

www.ADAchecklist.org

This checklist was produced by the New England ADA Center, a project of the Institute for Human Centered Design and a member of the ADA National Network. This checklist was developed under a grant from the Department of Education, NIDRR grant number H133A060092-09A. However the contents do not necessarily represent the policy of the Department of Education, and you should not assume endorsement by the Federal Government.

Questions or comments on the checklist contact the New England ADA Center at 617-695-0085 voice/tty or ADAinfo@NewEnglandADA.org

For the full set of checklists, including the checklists for recreation facilities visit www.ADAchecklist.org.

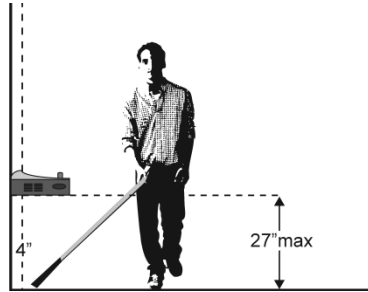
Priority 2 – Access to Goods & Services		Comments	Possible Solutions
<p>2.1 Does the accessible entrance provide direct access to the main floor, lobby and elevator?</p>	<input checked="" type="checkbox"/> Yes <input type="checkbox"/> No	<p>Photo #: 2.1</p>	<ul style="list-style-type: none"> • Create accessible route • •
<p>Interior Accessible Route (2010 Standards – Ch.4)</p>			
<p>2.2 Are all public spaces on at least one accessible route?</p>	<input checked="" type="checkbox"/> Yes <input type="checkbox"/> No	<p>Photo #: 2.1</p>	<ul style="list-style-type: none"> • Create accessible route • •
<p>2.3 Is the route stable, firm and slip-resistant?</p>	<input checked="" type="checkbox"/> Yes <input type="checkbox"/> No	<p>Photo #: 2.1</p>	<ul style="list-style-type: none"> • Repair uneven surfaces • •
<p>2.4 Is the route at least 36 inches wide?</p> <p>Note: The accessible route can narrow to 32 inches min. for a max. of 24 inches. These narrower portions of the route must be at least 48 inches from each other.</p>	<input checked="" type="checkbox"/> Yes <input type="checkbox"/> No Measurement: 94"	<p>36" min</p> <p>24" max 48" max 24" max</p> <p>32" min 32" min</p> <p>Photo #: 2.4</p>	<ul style="list-style-type: none"> • Widen route • •

<p>2.5 If the route is greater than 200 feet in length and no less than 36 inches wide, is there a passing space no less than 60 x 60 inches?</p>	<p><input type="checkbox"/> Yes <input type="checkbox"/> No</p> <p>Measurement:</p>		<p style="text-align: center;">NA</p> <p>Photo #:</p>	<ul style="list-style-type: none"> • Widen route for passing space • •
<p>2.6 Is the running slope no steeper than 1:20, i.e. for every inch of height change there are at least 20 inches of route run?</p>	<p><input type="checkbox"/> Yes <input type="checkbox"/> No</p> <p>Measurement:</p>		<p style="text-align: center;">NA</p> <p>Photo #:</p>	<ul style="list-style-type: none"> • Regrade • If steeper than 1:20 and no steeper than 1:12, treat as ramp and add other features such as edge protection and handrails •
<p>2.7 Is the cross slope no steeper than 1:48?</p>	<p><input type="checkbox"/> Yes <input type="checkbox"/> No</p> <p>Measurement:</p>		<p style="text-align: center;">NA</p> <p>Photo #:</p>	<ul style="list-style-type: none"> • Regrade • •
<p>2.8 Do all objects on circulation paths through public areas, e.g. fire extinguishers, drinking fountains, signs, etc., protrude no more than 4 inches into the path? Or If an object protrudes more than 4 inches, is the bottom leading edge at 27 inches or lower above the floor?</p>	<p><input type="checkbox"/> Yes <input checked="" type="checkbox"/> No</p> <p>Measurement: 18 1/2"</p> <p><input checked="" type="checkbox"/> Yes <input type="checkbox"/> No</p> <p>Measurement: 27"</p>	 <p style="text-align: center;">Or</p>	<p style="text-align: center;">ELECTRIC WATER COOLER</p> <p style="text-align: center;">(Not in direct circulation path)</p>	<ul style="list-style-type: none"> • Remove object • Add tactile warning such as permanent planter or partial walls •

Or
Is the bottom leading edge at 80 inches or higher above the floor?

Yes No

Measurement:
108"



Or

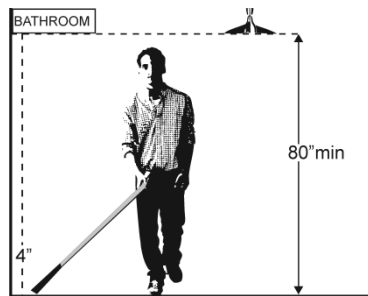


Photo #:
SECURITY CAMERA

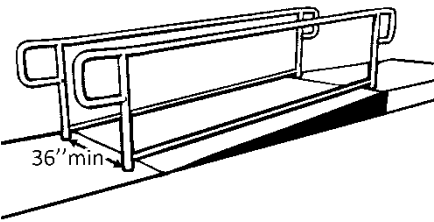
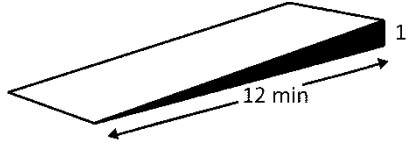
Photo #: **2.8**

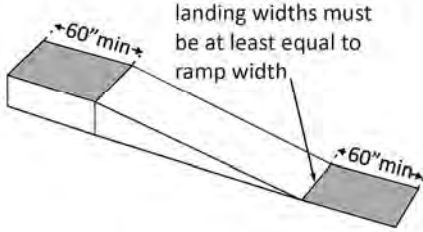
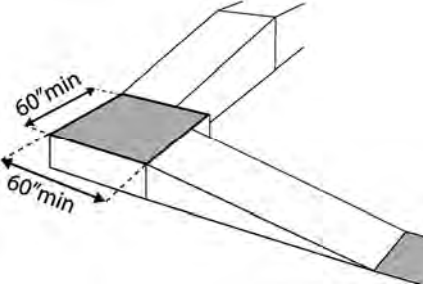
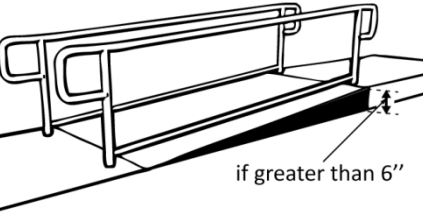
2.9 Are there elevators or platform lifts to all public stories?*

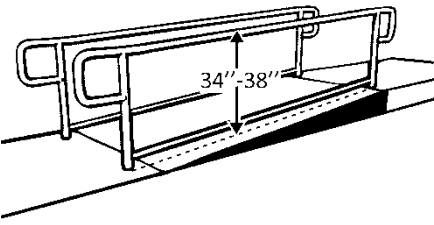
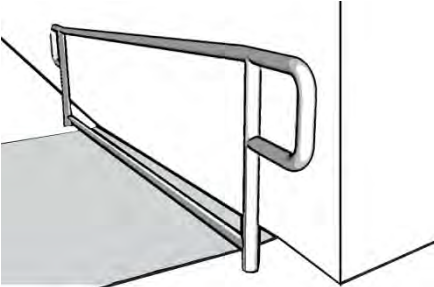
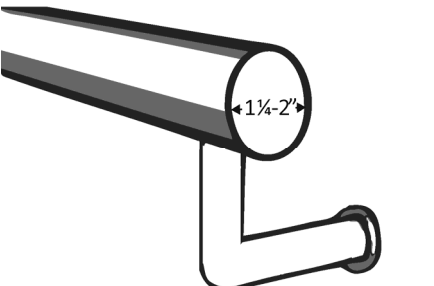
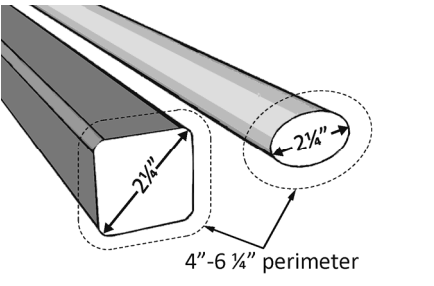
Yes No

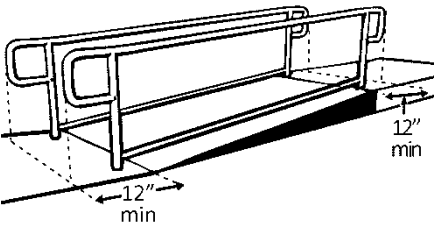
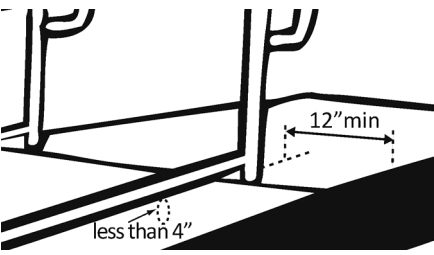
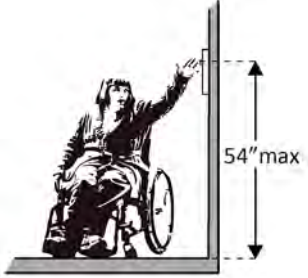
NA

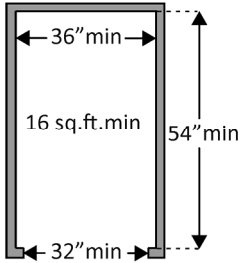
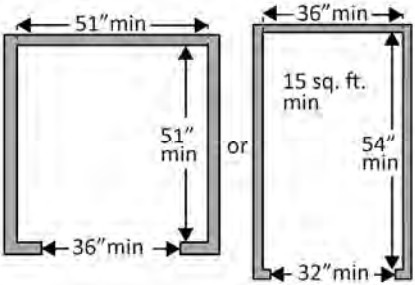
*Vertical access is not required in new construction or alterations if a facility is less than three stories or has less than 3,000 square feet per story, unless a facility is a shopping center, shopping mall, professional office of a health care provider, transportation terminal, state facility or government facility

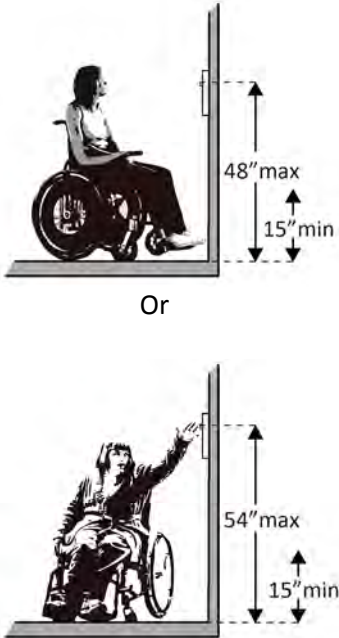

				<ul style="list-style-type: none"> • Install if necessary • Offer goods and services on an accessible story •
			Photo #:	
Ramps (2010 Standards 404 & 505)				
<p>2.10 If there is a ramp, is it at least 36 inches wide? If there are handrails, measure between the handrails.</p>	<input type="checkbox"/> Yes <input type="checkbox"/> No Measurement:		<p style="text-align: center;">NA</p>	<ul style="list-style-type: none"> • Alter ramp • •
			Photo #:	
<p>2.11 Is the surface stable, firm and slip resistant?</p>	<input type="checkbox"/> Yes <input type="checkbox"/> No		<p style="text-align: center;">NA</p>	<ul style="list-style-type: none"> • Change surface • •
			Photo #:	
<p>2.12 For each section of the ramp, is the running slope no greater than 1:12, i.e. for every inch of height change there are at least 12 inches of ramp run?</p> <p>Note: Rises no greater than 3 inches with a slope no steeper than 1:8 and rises no greater than 6 inches with a slope no steeper than 1:10 are permitted when due to space limitations.</p>	<input type="checkbox"/> Yes <input type="checkbox"/> No Measurement:		<p style="text-align: center;">NA</p>	<ul style="list-style-type: none"> • Lengthen ramp to decrease slope • Reconfigure ramp to include switchbacks • Relocate ramp •
			Photo #:	

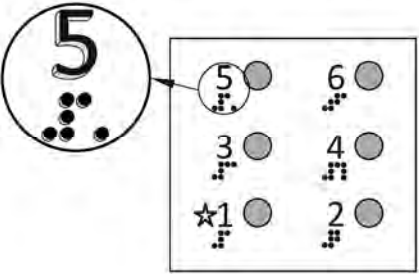
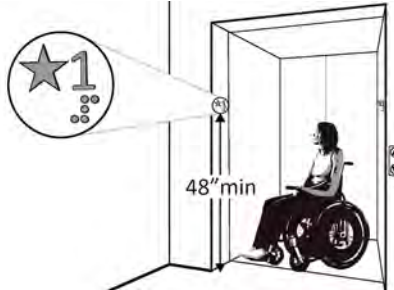
<p>2.13 Is there a level landing that is at least 60 inches long and at least as wide as the ramp:</p> <p>At the top of the ramp?</p> <p>At the bottom of the ramp?</p>	<p><input type="checkbox"/> Yes <input type="checkbox"/> No</p> <p>Measurement:</p> <p><input type="checkbox"/> Yes <input type="checkbox"/> No</p> <p>Measurement:</p>		<p style="text-align: center;">NA</p> <p>Photo #:</p>	<ul style="list-style-type: none"> • Alter ramp • Relocate ramp •
<p>2.14 Is there a level landing where the ramp changes direction that is at least 60 x 60 inches?</p>	<p><input type="checkbox"/> Yes <input type="checkbox"/> No</p> <p>Measurement:</p>		<p style="text-align: center;">NA</p> <p>Photo #:</p>	<ul style="list-style-type: none"> • Increase landing size • •
<p>2.15 If the ramp has a rise higher than 6 inches are there handrails on both sides?</p>	<p><input type="checkbox"/> Yes <input type="checkbox"/> No</p> <p>Measurement:</p>		<p style="text-align: center;">NA</p> <p>Photo #:</p>	<ul style="list-style-type: none"> • Add handrails • •


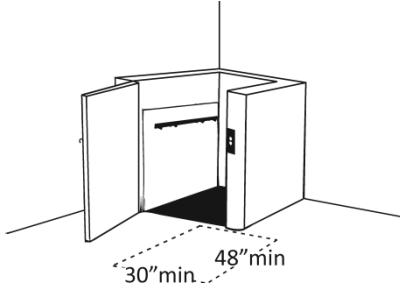
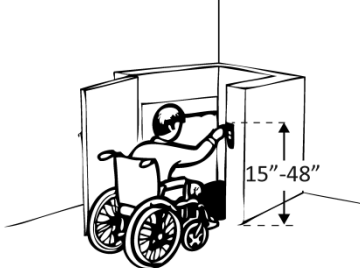
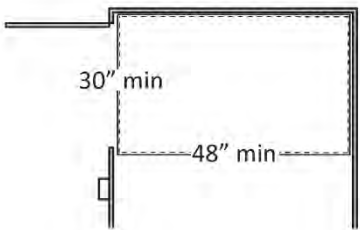
<p>2.16 Is the top of the handrail gripping surface no less than 34 inches and no greater than 38 inches above the ramp surface?</p>	<p><input type="checkbox"/> Yes <input type="checkbox"/> No</p> <p>Measurement:</p>		<p style="text-align: center;">NA</p> <p>Photo #:</p>	<ul style="list-style-type: none"> • Adjust handrail height • •
<p>2.17 Is the handrail gripping surface continuous and not obstructed along the top or sides?</p> <p>If there are obstructions, is the bottom of the handrail gripping surface obstructed by no more than 20%?</p>	<p><input type="checkbox"/> Yes <input type="checkbox"/> No</p> <p><input type="checkbox"/> Yes <input type="checkbox"/> No</p> <p>Measurement:</p>		<p style="text-align: center;">NA</p> <p>Photo #:</p>	<ul style="list-style-type: none"> • Regrade to 1:20 max • If steeper than 1:20 and no steeper than 1:12, treat as a ramp and add other features such as edge protection and handrails •
<p>2.18 If the handrail gripping surface is circular, is it no less than 1 ¼ inches and no greater than 2 inches in diameter?</p>	<p><input type="checkbox"/> Yes <input type="checkbox"/> No</p> <p>Measurement:</p>		<p style="text-align: center;">NA</p> <p>Photo #:</p>	<ul style="list-style-type: none"> • Alter handrails • •
<p>2.19 If the handrail gripping surface is non-circular, is it no less than 4 inches and no greater than 6 ½ inches in perimeter and no more than 2 ¼ inches in cross section?</p>	<p><input type="checkbox"/> Yes <input type="checkbox"/> No</p> <p>Measurement:</p>		<p style="text-align: center;">NA</p> <p>Photo #:</p>	<ul style="list-style-type: none"> • Alter handrails • •

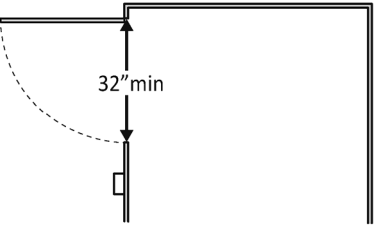
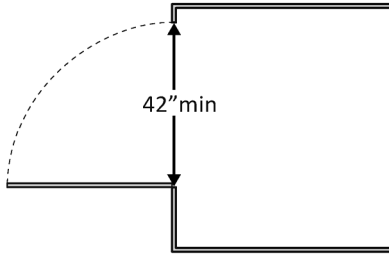
<p>2.20 Does the handrail:</p> <p>Extend at least 12 inches beyond the top and bottom of the ramp?</p> <p>Return to a wall, guard, or landing surface?</p>	<p><input type="checkbox"/> Yes <input type="checkbox"/> No</p> <p>Measurement:</p> <p><input type="checkbox"/> Yes <input type="checkbox"/> No</p>		<p style="text-align: center;">NA</p> <p>Photo #:</p>	<ul style="list-style-type: none"> • Alter handrails • • <p>If a 12" extension would be hazardous (in circulation path), it is not required</p>
<p>2.21 To prevent wheelchair casters and crutch tips from falling off:</p> <p>Does the surface of the ramp extend at least 12 inches beyond the inside face of the handrail?</p> <p>Or</p> <p>Is there a curb or barrier that prevents the passage of a 4-inch diameter sphere?</p>	<p><input type="checkbox"/> Yes <input type="checkbox"/> No</p> <p>Measurement:</p> <p><input type="checkbox"/> Yes <input type="checkbox"/> No</p> <p>Measurement:</p>		<p style="text-align: center;">NA</p> <p>Photo #:</p>	<ul style="list-style-type: none"> • Add curb • Add barrier • Extend ramp width • •
<p>Elevators – Full Size & LULA (limited use, limited application) (2010 Standards – 407 & 408) Note: LULA elevators are often used in alterations.</p>				
<p>2.22 If there is a full size or LULA elevator, are the call buttons no higher than 54 inches above the floor?</p>	<p><input type="checkbox"/> Yes <input type="checkbox"/> No</p> <p>Measurement:</p>		<p style="text-align: center;">NA</p> <p>Photo #:</p>	<ul style="list-style-type: none"> • Change call button height • •
<p>2.23 If there is a full size or LULA elevator, does the sliding door reopen automatically when obstructed by an object or person?*</p>	<p><input type="checkbox"/> Yes <input type="checkbox"/> No</p>		<p style="text-align: center;">NA</p>	<p>* If constructed before 3/15/2012 and manually operated, the door is not required to reopen automatically</p>

			<p>Photo #:</p>	<ul style="list-style-type: none"> • Install opener •
<p>2.24 If there is a LULA elevator with a swinging door:</p> <p>Is the door power- operated? <input type="checkbox"/> Yes <input type="checkbox"/> No</p> <p>Does the door remain open for at least 20 seconds when activated? <input type="checkbox"/> Yes <input type="checkbox"/> No</p> <p>Time:</p>			<p>Photo #:</p> <p style="text-align: center;">NA</p>	<ul style="list-style-type: none"> • Add power operated door • Adjust opening time •
<p>2.25 If there is a full size elevator:</p> <p>Is the interior at least 54 inches deep by at least 36 inches wide with at least 16 sq. ft. of clear floor area? <input type="checkbox"/> Yes <input type="checkbox"/> No</p> <p>Measurement:</p> <p>Is the door opening width at least 32 inches? <input type="checkbox"/> Yes <input type="checkbox"/> No</p> <p>Measurement:</p>			<p>Photo #:</p> <p style="text-align: center;">NA</p>	<ul style="list-style-type: none"> • Replace elevator • •
<p>2.26 If there is a LULA elevator, is the interior:</p> <p>At least 51 x 51 inches with a door opening width of at least 36 inches? <input type="checkbox"/> Yes <input type="checkbox"/> No</p> <p>Measurement:</p> <p>Or</p> <p>At least 54 inches deep by at least 36 inches wide with at least 15 sq. ft. of clear floor <input type="checkbox"/> Yes <input type="checkbox"/> No</p> <p>Measurement:</p>			<p>Photo #:</p> <p style="text-align: center;">NA</p>	<ul style="list-style-type: none"> • Replace elevator • •

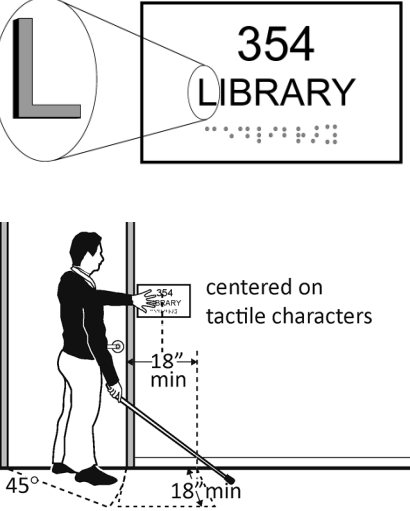
<p>area and a door opening width of at least 32 inches?</p>			<p>Photo #:</p>	
<p>2.27 If there is a full size or LULA elevator, are the in-car controls:</p> <p>No less than 15 inches and no greater 48 inches above the floor? Or Up to 54 inches above the floor for a parallel approach?</p>	<p><input type="checkbox"/> Yes <input type="checkbox"/> No Measurement:</p> <p><input type="checkbox"/> Yes <input type="checkbox"/> No Measurement:</p>	 <p>Or</p>	<p style="text-align: center;">NA</p> <p>Photo #:</p>	<ul style="list-style-type: none"> • Change control height • •
<p>2.28 If there is a LULA elevator, are the in-car controls centered on a side wall?</p>	<p><input type="checkbox"/> Yes <input type="checkbox"/> No Measurement:</p>		<p style="text-align: center;">NA</p> <p>Photo #:</p>	<ul style="list-style-type: none"> • Reconfigure controls • •

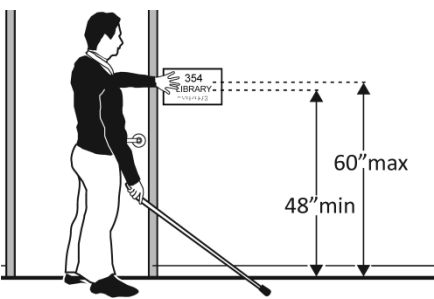
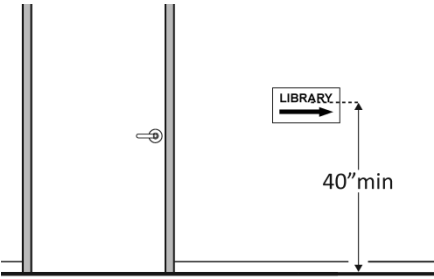
<p>2.29 If there is a full size or LULA elevator:</p> <p>Are the car control buttons designated with raised characters?</p> <p>Are the car control buttons designated with Braille?</p>	<p><input type="checkbox"/> Yes <input type="checkbox"/> No</p> <p><input type="checkbox"/> Yes <input type="checkbox"/> No</p>		<p>Photo #: NA</p>	<ul style="list-style-type: none"> • Add raised characters • Add Braille •
<p>2.30 If there is a full size or LULA elevator, are there audible signals which sound as the car passes or is about to stop at a floor?</p>	<p><input type="checkbox"/> Yes <input type="checkbox"/> No</p>		<p>Photo #: NA</p>	<ul style="list-style-type: none"> • Install audible signals • •
<p>2.31 If there is a full size or LULA elevator:</p> <p>Is there a sign on both door jambs at every floor identifying the floor?</p> <p>Is there a tactile star on both jambs at the main entry level?</p> <p>Do text characters contrast with their backgrounds?</p> <p>Are text characters raised?</p> <p>Is there Braille?</p> <p>Is the sign mounted between 48 inches to the baseline of the lowest character and 60 inches to the baseline of the highest character above the floor?*</p>	<p><input type="checkbox"/> Yes <input type="checkbox"/> No</p> <p><input type="checkbox"/> Yes <input type="checkbox"/> No</p> <p><input type="checkbox"/> Yes <input type="checkbox"/> No</p> <p><input type="checkbox"/> Yes <input type="checkbox"/> No</p> <p><input type="checkbox"/> Yes <input type="checkbox"/> No</p> <p><input type="checkbox"/> Yes <input type="checkbox"/> No</p> <p>Measurement:</p>		<p>Photo #: NA</p>	<ul style="list-style-type: none"> • Install signs • Change sign height • • <p>* If constructed before 3/15/2012 and mounted no higher than 60 inches to the centerline of the sign, relocation is not required</p>

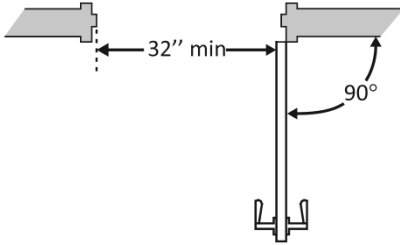
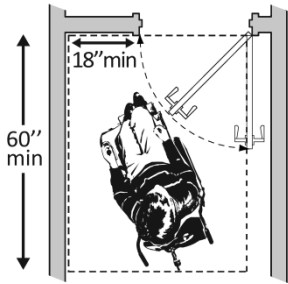
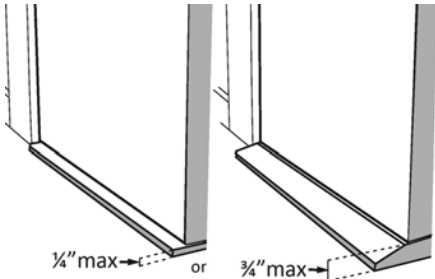
Platform Lifts (2010 Standards – 410)				
<p>2.32 If a lift is provided, can it be used without assistance from others?</p>	<p><input type="checkbox"/> Yes <input type="checkbox"/> No</p>		<p style="text-align: center;">NA</p> <p>Photo #:</p>	<ul style="list-style-type: none"> • Reconfigure so independently operable • •
<p>2.33 Is there a clear floor space at least 30 inches wide by at least 48 inches long for a person using a wheelchair to approach and reach the controls to use the lift?</p>	<p><input type="checkbox"/> Yes <input type="checkbox"/> No</p> <p>Measurement:</p>		<p style="text-align: center;">NA</p> <p>Photo #:</p>	<ul style="list-style-type: none"> • Remove obstructions • •
<p>2.34 Are the lift controls no less than 15 inches and no greater than 48 inches above the floor?</p>	<p><input type="checkbox"/> Yes <input type="checkbox"/> No</p> <p>Measurement:</p>		<p style="text-align: center;">NA</p> <p>Photo #:</p>	<ul style="list-style-type: none"> • Change control height • •
<p>2.35 Is there a clear floor space at least 30 inches wide by at least 48 inches long inside the lift?</p>	<p><input type="checkbox"/> Yes <input type="checkbox"/> No</p> <p>Measurement:</p>		<p style="text-align: center;">NA</p> <p>Photo #:</p>	<ul style="list-style-type: none"> • Replace lift • •

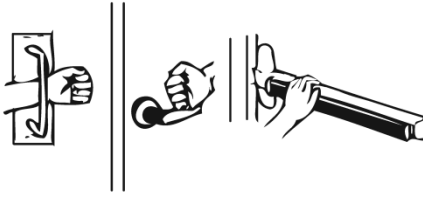
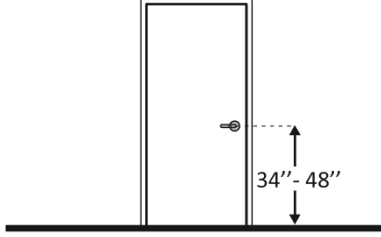

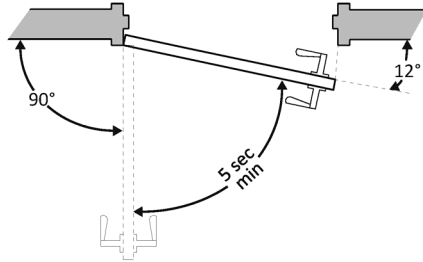
<p>2.36 If there is an end door, is the clear opening width at least 32 inches?</p>	<p><input type="checkbox"/> Yes <input type="checkbox"/> No</p> <p>Measurement:</p>		<p style="text-align: center; color: red; font-weight: bold;">NA</p> <p>Photo #:</p>	<ul style="list-style-type: none"> • Alter door width • •
<p>2.37 If there is a side door, is the clear opening width at least 42 inches?</p>	<p><input type="checkbox"/> Yes <input type="checkbox"/> No</p> <p>Measurement:</p>		<p style="text-align: center; color: red; font-weight: bold;">NA</p> <p>Photo #:</p>	<ul style="list-style-type: none"> • Alter door width • •

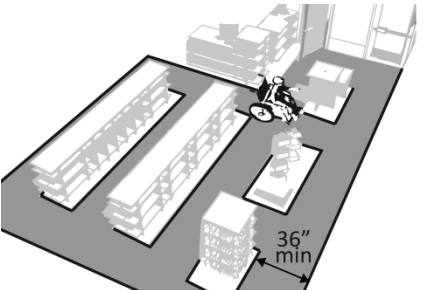

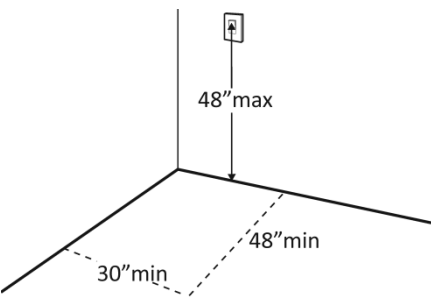
Signs (2010 Standards – 703) Note: “Tactile characters” are read using touch, i.e. raised characters and Braille.

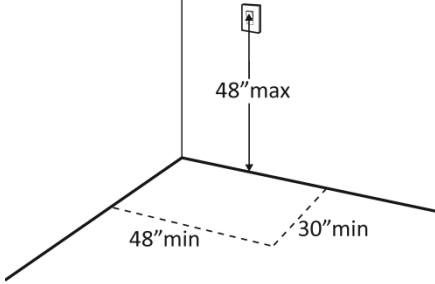
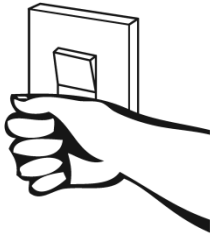
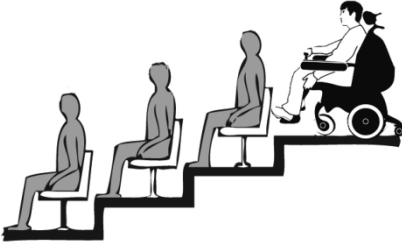
<p>2.38 If there are signs designating permanent rooms and spaces not likely to change over time, e.g. room numbers and letters, room names, and exit signs:</p> <p>Do text characters contrast with their backgrounds?</p> <p>Are text characters raised?</p> <p>Is there Braille?</p> <p>Is the sign mounted: On the wall on the latch side of the door?</p>	<p><input checked="" type="checkbox"/> Yes <input type="checkbox"/> No</p> <p><input type="checkbox"/> Yes <input checked="" type="checkbox"/> No</p> <p><input type="checkbox"/> Yes <input checked="" type="checkbox"/> No</p> <p><input checked="" type="checkbox"/> Yes <input type="checkbox"/> No</p>		<p>Photo #:</p>	<ul style="list-style-type: none"> • Install tactile sign • Relocate sign •
---	---	---	-----------------	--

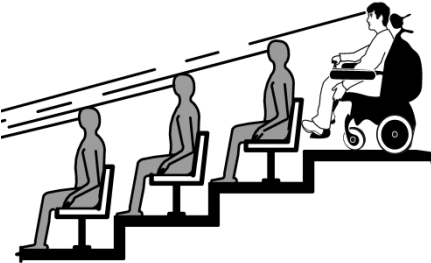
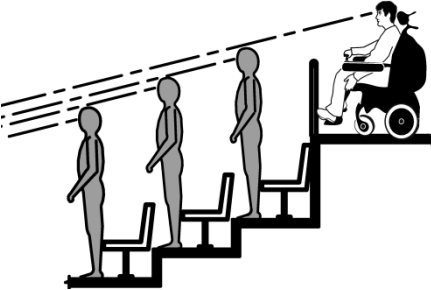

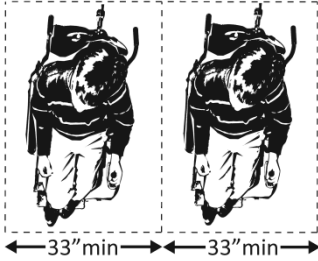
<p>Note: Signs are permitted on the push side of doors with closers and without hold-open devices.</p> <p>With clear floor space beyond the arc of the door swing between the closed position and 45-degree open position, at least 18 x 18 inches centered on the tactile characters?*</p> <p>So the baseline of the lowest character is at least 48 inches above the floor and the baseline of the highest character is no more than 60 inches above the floor? *</p> <p>Note: If the sign is at double doors with one active leaf, the sign should be on the inactive leaf; if both leaves are active, the sign should be on the wall to the right of the right leaf.</p>	<p><input type="checkbox"/> Yes <input type="checkbox"/> No</p> <p>Measurement:</p> <p><input type="checkbox"/> Yes <input type="checkbox"/> No</p> <p>Measurement:</p>		<p style="text-align: center; color: red; font-weight: bold;">NA</p> <p>Photo #: 2.38</p>	<p>*If constructed before 3/15/2010 and a person may approach within 3 inches of the sign without encountering protruding objects or standing within the door swing, relocation not required</p> <p>*If constructed before 3/15/2012 and mounted no higher than 60 inches to the centerline of the sign, relocation not required</p>
<p>2.39 If there are signs that provide direction to or information about interior spaces:</p> <p>Do text characters contrast with their backgrounds?</p> <p>Is the sign mounted so that characters are at least 40 inches above the floor?</p>	<p><input type="checkbox"/> Yes <input type="checkbox"/> No</p> <p><input type="checkbox"/> Yes <input type="checkbox"/> No</p> <p>Measurement:</p>		<p style="text-align: center; color: red; font-weight: bold;">NA</p> <p>Photo #:</p>	<ul style="list-style-type: none"> • Install signs with contrasting characters • Change sign height • <p>Raised characters and Braille are not required</p>

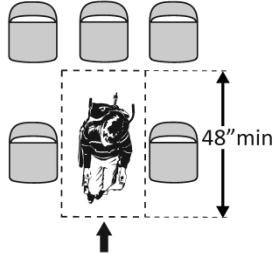
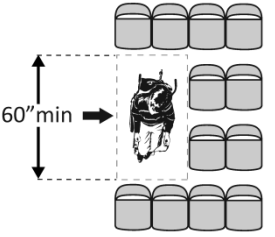
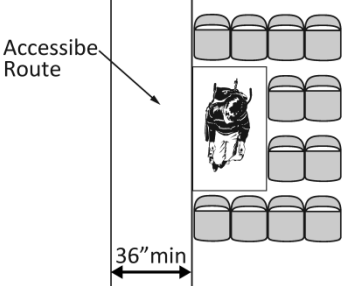
Interior Doors – to classrooms, medical exam rooms, conference rooms, etc. (2010 Standards – 404)				
<p>2.40 Is the door opening width at least 32 inches clear, between the face of the door and the stop, when the door is open 90 degrees?</p>	<p><input type="checkbox"/> Yes <input type="checkbox"/> No Measurement:</p>		<p style="text-align: center;">NA</p> <p>Photo #:</p>	<ul style="list-style-type: none"> • Install offset hinges • Alter the doorway •
<p>2.41 If there is a front approach to the pull side of the door, is there at least 18 inches of maneuvering clearance beyond the latch side plus at least 60 inches clear depth?</p> <p>On both sides of the door, is the floor surface of the maneuvering clearance level (no steeper than 1:48)?</p>	<p><input type="checkbox"/> Yes <input type="checkbox"/> No Measurement:</p> <p><input type="checkbox"/> Yes <input type="checkbox"/> No Measurement:</p>		<p style="text-align: center;">NA</p> <p>Photo #:</p>	<ul style="list-style-type: none"> • Remove obstructions • Reconfigure walls • Add automatic door opener <p>See 2010 Standards 404.2.4 for maneuvering clearance requirements on the push side of the door and side approaches to the pull side of the door</p>
<p>2.42 Is the door threshold edge no more than ¼ inch high?</p> <p>Or</p> <p>No more than ¾ inch high if slope is beveled no steeper than 1:2?</p> <p>Note: The first ¼ inch of the threshold may be vertical; the rest must be beveled.</p>	<p><input type="checkbox"/> Yes <input type="checkbox"/> No Measurement:</p> <p><input type="checkbox"/> Yes <input type="checkbox"/> No Measurement:</p>		<p style="text-align: center;">NA</p> <p>Photo #:</p>	<ul style="list-style-type: none"> • Remove or replace threshold • •

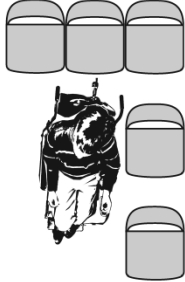

<p>2.43 Is the door equipped with hardware that is operable with one hand and does not require tight grasping, pinching and twisting of the wrist?</p>	<p><input type="checkbox"/> Yes <input type="checkbox"/> No</p>		<p style="text-align: center;">NA</p> <p>Photo #:</p>	<ul style="list-style-type: none"> • Replace inaccessible knob with lever, loop or push hardware • Add automatic door opener •
<p>2.44 Are the operable parts of the hardware no less than 34 inches and no greater than 48 inches above the floor?</p>	<p><input type="checkbox"/> Yes <input type="checkbox"/> No</p> <p>Measurement:</p>		<p style="text-align: center;">NA</p> <p>Photo #:</p>	<ul style="list-style-type: none"> • Change hardware height • •
<p>2.45 Can the door be opened easily (5 pounds maximum force)?</p> <p>Note: You can use a pressure gauge or fish scale to measure force. If you do not have a pressure gauge or fish scale you will need to judge whether the door is easy to open.</p>	<p><input type="checkbox"/> Yes <input type="checkbox"/> No</p> <p>Measurement:</p>		<p style="text-align: center;">NA</p> <p>Photo #:</p>	<ul style="list-style-type: none"> • Adjust or replace closers • Install lighter doors • Install power-assisted or automatic door openers
<p>2.46 If the door has a closer, does it take at least 5 seconds to close from an open position of 90 degrees to a position of 12 degrees from the latch?</p>	<p><input type="checkbox"/> Yes <input type="checkbox"/> No</p> <p>Measurement:</p>		<p style="text-align: center;">NA</p> <p>Photo #:</p>	<ul style="list-style-type: none"> • Adjust closer • •

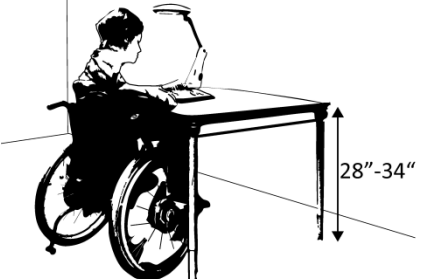
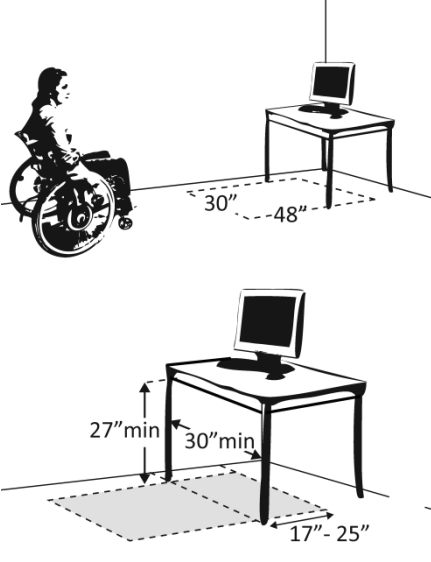
Rooms and Spaces – stores, supermarkets, libraries, etc. (2010 Standards – 302, 304, & 402)				
<p>2.47 Are aisles and pathways to goods and services, and to one of each type of sales and service counters, at least 36 inches wide?</p>	<p><input type="checkbox"/> Yes <input type="checkbox"/> No</p> <p>Measurement:</p>		<p style="text-align: center;">NA</p> <p>Photo #:</p>	<ul style="list-style-type: none"> • Rearrange goods, equipment and furniture • •
<p>2.48 Are floor surfaces stable, firm and slip resistant?</p>	<p><input checked="" type="checkbox"/> Yes <input type="checkbox"/> No</p>		<p>Photo #: 2.8</p>	<ul style="list-style-type: none"> • Change floor surface • •
<p>2.49 If there is carpet:</p> <p>Is it no higher than ½ inch?</p> <p>Is it securely attached along the edges?</p>	<p><input type="checkbox"/> Yes <input type="checkbox"/> No</p> <p>Measurement:</p> <p><input type="checkbox"/> Yes <input type="checkbox"/> No</p>		<p style="text-align: center;">NA</p> <p>Photo #:</p>	<ul style="list-style-type: none"> • Replace carpet • •
Controls – light switches, security and intercom systems, emergency/alarm boxes, etc. (2010 Standards – 309)				
<p>2.50 Is there a clear floor space at least 30 inches wide by at least 48 inches long for a forward or parallel approach?</p> <p>Are the operable parts no higher than 48 inches above the floor?*</p>	<p><input type="checkbox"/> Yes <input type="checkbox"/> No</p> <p>Measurement:</p> <p><input type="checkbox"/> Yes <input type="checkbox"/> No</p> <p>Measurement:</p>		<p style="text-align: center;">NA</p>	<ul style="list-style-type: none"> • Change height of control • • <p>*If constructed before 3/15/2012 and a parallel approach is provided, controls can be 54 inches above the floor</p>

			<p>Photo #:</p>													
<p>2.51 Can the control be operated with one hand and without tight grasping, pinching, or twisting of the wrist?</p>	<p><input type="checkbox"/> Yes <input type="checkbox"/> No</p>		<p style="text-align: center;">NA</p> <p>Photo #:</p>	<ul style="list-style-type: none"> • Replace control • • 												
<p>Seating: Assembly Areas – theaters, auditoriums, stadiums, theater style classrooms, etc. (2010 Standards – 221 & 802)</p>																
<p>2.52 Are an adequate number of wheelchair spaces provided?</p>	<p><input type="checkbox"/> Yes <input type="checkbox"/> No</p> <p>Total #:</p> <p>Wheelchair #:</p>	<table border="1" style="width: 100%; border-collapse: collapse;"> <thead> <tr> <th style="text-align: center;"># of Seats</th> <th style="text-align: center;">Wheelchair Spaces</th> </tr> </thead> <tbody> <tr> <td style="text-align: center;">4 - 25</td> <td style="text-align: center;">1</td> </tr> <tr> <td style="text-align: center;">26 - 50</td> <td style="text-align: center;">2</td> </tr> <tr> <td style="text-align: center;">51 - 150</td> <td style="text-align: center;">4</td> </tr> <tr> <td style="text-align: center;">151 - 300</td> <td style="text-align: center;">5</td> </tr> <tr> <td colspan="2" style="text-align: center;">300+ see 2010 Standards 221.2.1.</td> </tr> </tbody> </table>	# of Seats	Wheelchair Spaces	4 - 25	1	26 - 50	2	51 - 150	4	151 - 300	5	300+ see 2010 Standards 221.2.1.		<p style="text-align: center;">NA</p> <p>Photo #:</p>	<ul style="list-style-type: none"> • Reconfigure to add wheelchair spaces • •
# of Seats	Wheelchair Spaces															
4 - 25	1															
26 - 50	2															
51 - 150	4															
151 - 300	5															
300+ see 2010 Standards 221.2.1.																
<p>2.53 Are wheelchair spaces dispersed to allow location choices and viewing angles equivalent to other seating, including specialty seating areas that provide distinct services and amenities?</p>	<p><input type="checkbox"/> Yes <input type="checkbox"/> No</p>		<p style="text-align: center;">NA</p> <p>Photo #:</p>	<ul style="list-style-type: none"> • Reconfigure to disperse wheelchair spaces • • 												

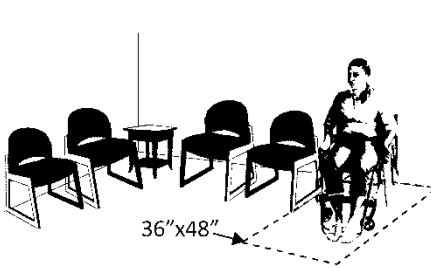
<p>2.54 Where people are expected to remain seated, do people in wheelchair spaces have a clear line of sight over and between the heads of others in front of them?</p>	<p><input type="checkbox"/> Yes <input type="checkbox"/> No</p>		<p style="text-align: center;">NA</p> <p>Photo #:</p>	<ul style="list-style-type: none"> • Alter for line of sight • •
<p>2.55 Where people are expected to stand, do people in wheelchair spaces have a clear line of sight over and between the heads of others in front of them?</p>	<p><input type="checkbox"/> Yes <input type="checkbox"/> No</p>		<p style="text-align: center;">NA</p> <p>Photo #:</p>	<ul style="list-style-type: none"> • Alter for line of sight • •
<p>2.56 If there is a single wheelchair space, is it at least 36 inches wide?</p>	<p><input type="checkbox"/> Yes <input type="checkbox"/> No</p> <p>Measurement:</p>		<p style="text-align: center;">NA</p> <p>Photo #:</p>	<ul style="list-style-type: none"> • Alter space • •
<p>2.57 If there are two adjacent wheelchair spaces, are they each at least 33 inches wide?</p>	<p><input type="checkbox"/> Yes <input type="checkbox"/> No</p> <p>Measurement:</p>		<p style="text-align: center;">NA</p> <p>Photo #:</p>	<ul style="list-style-type: none"> • Alter spaces • •

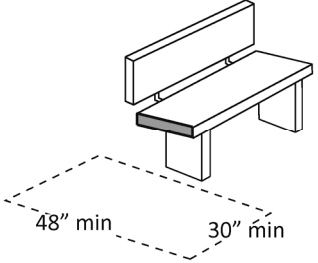
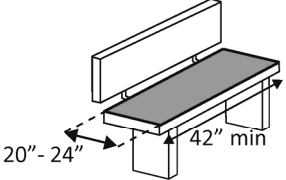
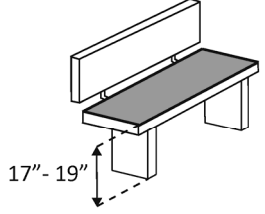
<p>2.58 If the wheelchair space can be entered from the front or rear, is it at least 48 inches deep?</p>	<p><input type="checkbox"/> Yes <input type="checkbox"/> No</p> <p>Measurement:</p>		<p style="text-align: center;">NA</p> <p>Photo #:</p>	<ul style="list-style-type: none"> • Alter space • •
<p>2.59 If the wheelchair space can only be entered from the side, is it at least 60 inches deep?</p>	<p><input type="checkbox"/> Yes <input type="checkbox"/> No</p> <p>Measurement:</p>		<p style="text-align: center;">NA</p> <p>Photo #:</p>	<ul style="list-style-type: none"> • Alter space • •
<p>2.60 Do wheelchair spaces adjoin, but not overlap, accessible routes?</p>	<p><input type="checkbox"/> Yes <input type="checkbox"/> No</p>		<p style="text-align: center;">NA</p> <p>Photo #:</p>	<ul style="list-style-type: none"> • Alter spaces • •
<p>2.61 Is there at least one companion seat for each wheelchair space?</p>	<p><input type="checkbox"/> Yes <input type="checkbox"/> No</p>		<p style="text-align: center;">NA</p> <p>Photo #:</p>	<ul style="list-style-type: none"> • Add companion seats • •

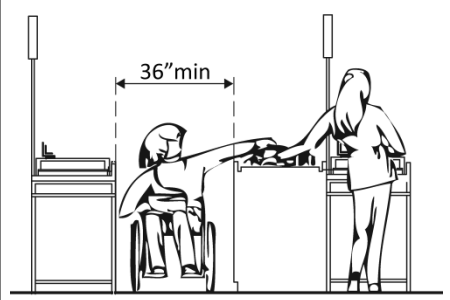
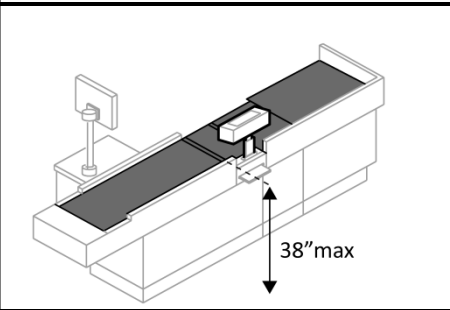
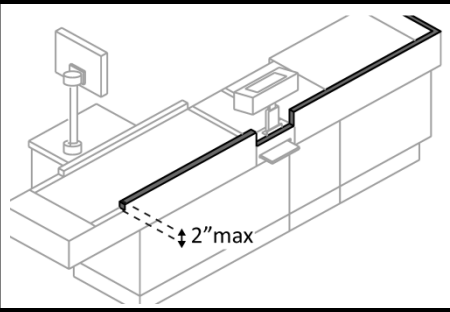
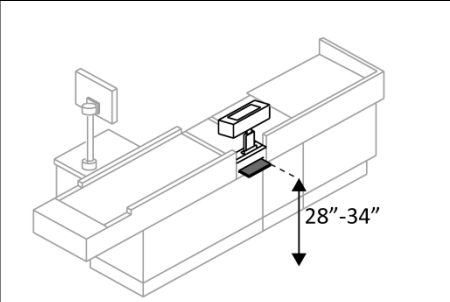
<p>2.62 Is the companion seat located so the companion is shoulder-to-shoulder with the person in a wheelchair?</p>	<p><input type="checkbox"/> Yes <input type="checkbox"/> No</p>		<p style="text-align: center;">NA</p> <p>Photo #:</p>	<ul style="list-style-type: none"> • Alter seating • •
<p>2.63 Is the companion seat equivalent in size, quality, comfort and amenities to seating in the immediate area?</p>	<p><input type="checkbox"/> Yes <input type="checkbox"/> No</p>		<p style="text-align: center;">NA</p> <p>Photo #:</p>	<ul style="list-style-type: none"> • Add equivalent seating • •
<p>Seating: At dining surfaces (restaurants, cafeterias, bars, etc.) and non-employee work surfaces (libraries, conference rooms, etc.) (2010 Standards – 226 & 902)</p>				
<p>2.64 Are at least 5%, but no fewer than one, of seating and standing spaces accessible for people who use wheelchairs?</p>	<p><input type="checkbox"/> Yes <input type="checkbox"/> No</p> <p>Total #:</p> <p>Wheelchair #:</p>		<p style="text-align: center;">NA</p> <p>Photo #:</p>	<ul style="list-style-type: none"> • Alter to provide accessible spaces • •
<p>2.65 Is there a route at least 36 inches wide to accessible seating?</p>	<p><input type="checkbox"/> Yes <input type="checkbox"/> No</p> <p>Measurement:</p>		<p style="text-align: center;">NA</p> <p>Photo #:</p>	<ul style="list-style-type: none"> • Widen route • •


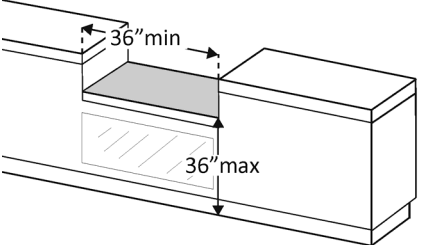
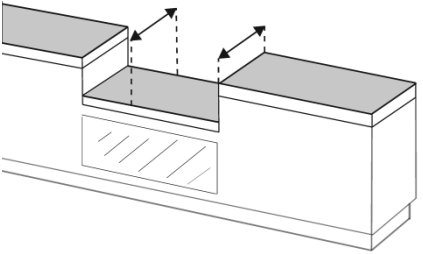
<p>2.66 At the accessible space(s), is the top of the accessible surface no less than 28 inches and no greater than 34 inches above the floor?</p>	<p><input type="checkbox"/> Yes <input type="checkbox"/> No</p> <p>Measurement:</p>		<p style="text-align: center;">NA</p> <p>Photo #:</p>	<ul style="list-style-type: none"> • Alter surface height • •
<p>2.67 Is there a clear floor space at least 30 inches wide by at least 48 inches long for a forward approach?</p> <p>Does it extend no less than 17 inches and no greater than 25 inches under the surface?</p> <p>Is there knee space at least 27 inches high and at least 30 inches wide?</p>	<p><input type="checkbox"/> Yes <input type="checkbox"/> No</p> <p>Measurement:</p> <p><input type="checkbox"/> Yes <input type="checkbox"/> No</p> <p>Measurement:</p> <p><input type="checkbox"/> Yes <input type="checkbox"/> No</p> <p>Measurement:</p>		<p style="text-align: center;">NA</p> <p>Photo #:</p>	<ul style="list-style-type: none"> • Alter table or work surface • Add accessible table or work surface •

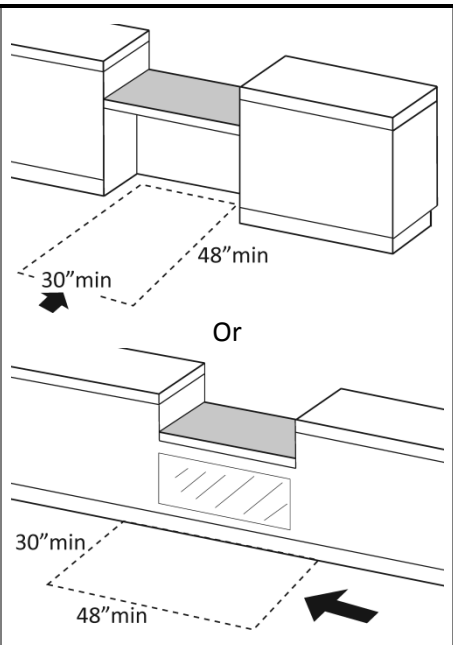
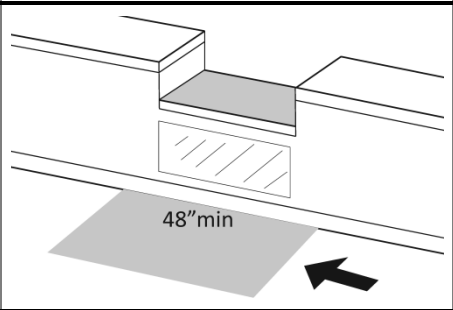
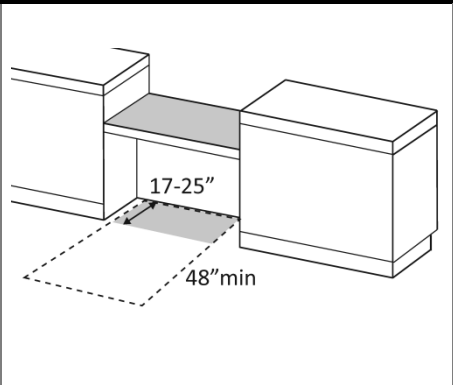
Seating: General – reception areas, waiting rooms, etc. (2010 Standards – 801)

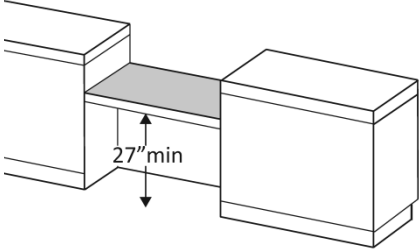
<p>2.68 Is there at least one space at least 36 inches wide by at least 48 inches long for a person in a wheelchair?</p>	<p><input checked="" type="checkbox"/> Yes <input type="checkbox"/> No</p> <p>Measurement:</p> <p style="color: red;">36" X 48"</p>		<p>Photo #: 2.68</p>	<ul style="list-style-type: none"> • Move furniture and equipment to provide space • •
---	--	--	-----------------------------	---

Benches – In locker rooms, dressing rooms, fitting rooms (2010 Standards – 803 & 903)				
<p>2.69 In locker rooms, dressing rooms and fitting rooms, is there at least one room with a bench?</p>	<p><input type="checkbox"/> Yes <input type="checkbox"/> No</p>		<p>NA</p>	<ul style="list-style-type: none"> • Add bench • •
<p>2.70 Is there a clear floor space at least 30 inches wide by at least 48 inches long at the end of the bench and parallel to the short axis of the bench?</p> <p>Is the bench seat at least 42 inches long and no less than 20 inches and no greater than 24 inches deep?</p> <p>Does the bench have back support or is it affixed to a wall?</p> <p>Is the top of the bench seat no less than 17 inches and no greater than 19 inches above the floor?</p>	<p><input type="checkbox"/> Yes <input type="checkbox"/> No Measurement:</p> <p><input type="checkbox"/> Yes <input type="checkbox"/> No Measurement:</p> <p><input type="checkbox"/> Yes <input type="checkbox"/> No</p> <p><input type="checkbox"/> Yes <input type="checkbox"/> No Measurement:</p>	  	<p>NA</p>	<ul style="list-style-type: none"> • Move bench • Replace bench • Affix bench to wall • •

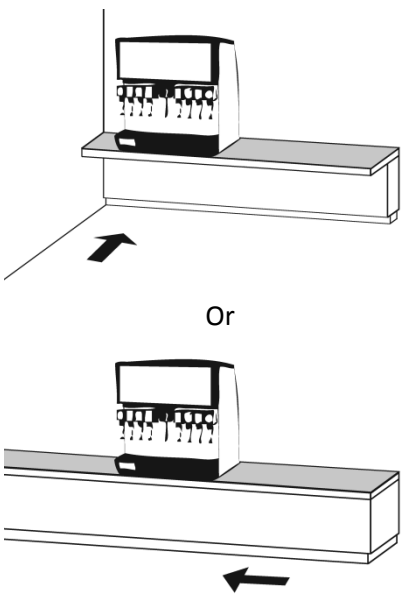
Check-Out Aisles – supermarkets, large retail stores, etc. (2010 Standards – 904)				
<p>2.71 Is the aisle at least 36 inches wide?</p> <p><input type="checkbox"/> Yes <input type="checkbox"/> No</p> <p>Measurement:</p>		<p>Photo #:</p>	<p>NA</p>	<ul style="list-style-type: none"> • Widen aisle • •
<p>2.72 Is the counter surface of at least one aisle no higher than 38 inches above the floor?</p> <p><input type="checkbox"/> Yes <input type="checkbox"/> No</p> <p>Measurement:</p>		<p>Photo #:</p>	<p>NA</p>	<ul style="list-style-type: none"> • Lower counter • •
<p>2.73 Is the top of the counter edge protection no higher than 2 inches above the counter surface?</p> <p><input type="checkbox"/> Yes <input type="checkbox"/> No</p> <p>Measurement:</p>		<p>Photo #:</p>	<p>NA</p>	<ul style="list-style-type: none"> • Lower edge protection • •
<p>2.74 If there is a check writing surface, is the top no less than 28 inches and no greater than 34 inches above the floor?</p> <p><input type="checkbox"/> Yes <input type="checkbox"/> No</p> <p>Measurement:</p>		<p>Photo #:</p>	<p>NA</p>	<ul style="list-style-type: none"> • Alter check writing surface • •

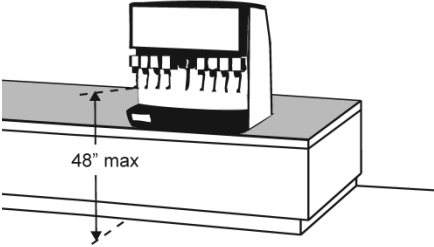
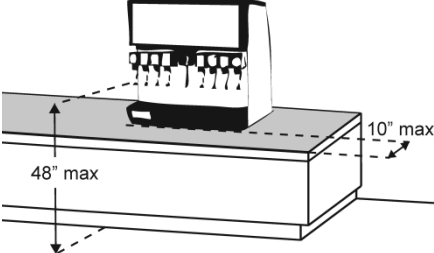
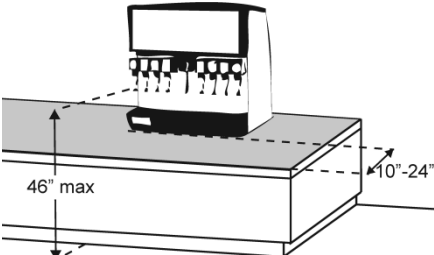
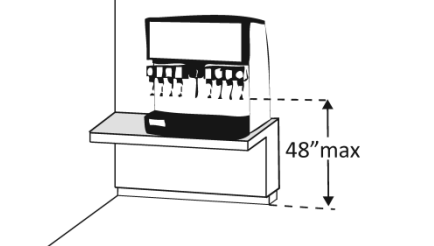
<p>2.75 If there is more than one check-out aisle is there a sign with the International Symbol of Accessibility at the accessible aisle?</p>	<p><input type="checkbox"/> Yes <input type="checkbox"/> No</p>		<p style="text-align: center;">NA</p> <p>Photo #:</p>	<ul style="list-style-type: none"> • Add sign • •
<p>Sales & Service Counters – banks, stores, dry cleaners, auto repair shops, fitness clubs, etc. (2010 Standards – 904)</p>				
<p>2.76 Is there a portion of at least one of each type of counter that is: No higher than 36 inches above the floor? At least 36 inches long?</p>	<p><input type="checkbox"/> Yes <input type="checkbox"/> No Measurement: <input type="checkbox"/> Yes <input type="checkbox"/> No Measurement:</p>		<p style="text-align: center;">NA</p> <p>Photo #:</p>	<ul style="list-style-type: none"> • Lower section of counter • Lengthen section of counter •
<p>2.77 Does the accessible portion of the counter extend the same depth as the counter top?</p>	<p><input type="checkbox"/> Yes <input type="checkbox"/> No Measurement:</p>		<p style="text-align: center;">NA</p> <p>Photo #:</p>	<ul style="list-style-type: none"> • Alter accessible portion • •

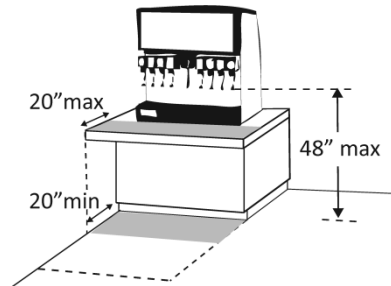
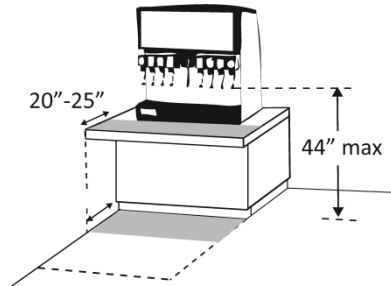
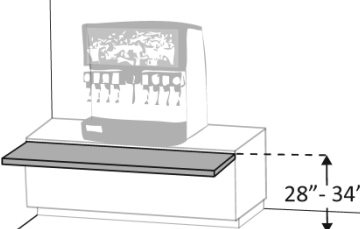
<p>2.78 Is there a clear floor space at least 30 inches wide by at least 48 inches long for a forward or parallel approach?</p>	<p><input type="checkbox"/> Yes <input type="checkbox"/> No</p> <p><input type="checkbox"/> Parallel Measurement:</p> <p><input type="checkbox"/> Forward Measurement:</p>		<p style="text-align: center; color: red; font-weight: bold;">NA</p> <p>Photo #:</p>	<ul style="list-style-type: none"> • Reconfigure to provide a parallel or forward approach • •
<p>2.79 For a parallel approach, is the clear floor space positioned with the 48 inches adjacent to the accessible length of counter?</p>	<p><input type="checkbox"/> Yes <input type="checkbox"/> No</p> <p>Measurement:</p>		<p style="text-align: center; color: red; font-weight: bold;">NA</p> <p>Photo #:</p>	<ul style="list-style-type: none"> • If a parallel approach is not possible, a forward approach is required • •
<p>2.80 For a forward approach:</p> <p>Do no less than 17 and no greater than 25 inches of the clear floor space extend under the accessible length of the counter?</p> <p>Is there at least 27 inches clearance from the floor to the</p>	<p><input type="checkbox"/> Yes <input type="checkbox"/> No</p> <p>Measurement:</p> <p><input type="checkbox"/> Yes <input type="checkbox"/> No</p>		<p style="text-align: center; color: red; font-weight: bold;">NA</p> <p>Photo #:</p>	<ul style="list-style-type: none"> • Reconfigure to provide knee clearance • •

<p>bottom of the counter?</p>	<p>Measurement:</p>		<p>Photo #:</p>	
-------------------------------	---------------------	--	-----------------	--

Food Service Lines – in cafeterias, salad bars, eat-in fast food establishments, etc. (2010 Standards – 904)

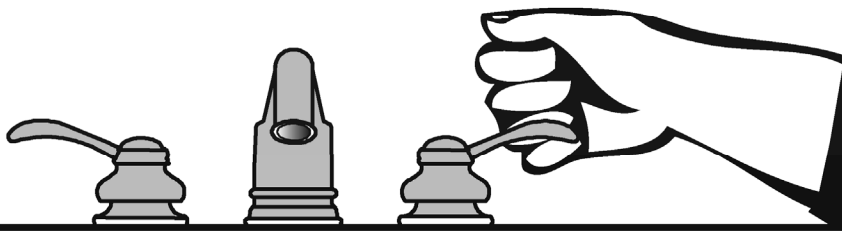
<p>2.81 Does at least one of each type of self-service shelf or dispensing device for tableware, dishware, condiments, food and beverages have a forward or parallel approach?</p>	<p><input type="checkbox"/> Yes <input type="checkbox"/> No</p> <p><input type="checkbox"/> Forward</p> <p><input type="checkbox"/> Parallel</p>		<p style="color: red; text-align: center;">NA</p> <p>Photo #:</p>	<ul style="list-style-type: none"> • Reconfigure to provide approach • •
---	--	---	---	---

<p>2.82 If there is an unobstructed parallel approach, is the shelf or dispensing device no higher than 48 inches above the floor?</p>	<p><input type="checkbox"/> Yes <input type="checkbox"/> No</p> <p>Measurement:</p>		<p>Photo #:</p> <p style="text-align: center;">NA</p>	<ul style="list-style-type: none"> • Lower shelf and/or dispensing device • •
<p>2.83 If there is a shallow obstruction no deeper than 10 inches with a parallel approach, is the shelf or dispensing device no higher than 48 inches above the floor?</p>	<p><input type="checkbox"/> Yes <input type="checkbox"/> No</p> <p>Measurement:</p>		<p>Photo #:</p> <p style="text-align: center;">NA</p>	<ul style="list-style-type: none"> • Lower shelf and/or dispensing device • •
<p>2.84 If there is an obstruction no less than 10 inches and no greater than 24 inches deep with a parallel approach, is the shelf or dispensing device no higher than 46 inches above the floor?</p>	<p><input type="checkbox"/> Yes <input type="checkbox"/> No</p> <p>Measurement:</p>		<p>Photo #:</p> <p style="text-align: center;">NA</p>	<ul style="list-style-type: none"> • Lower shelf and/or dispensing device • •
<p>2.85 If there is an unobstructed forward approach, is the shelf or dispensing device no higher than 48 inches above the floor?</p>	<p><input type="checkbox"/> Yes <input type="checkbox"/> No</p> <p>Measurement:</p>		<p>Photo #:</p> <p style="text-align: center;">NA</p>	<ul style="list-style-type: none"> • Lower shelf and/or dispensing device • •

<p>2.86 If there is an obstruction no deeper than 20 inches with a forward approach:</p> <p>Does clear floor space extend under the obstruction that is at least the same depth as the obstruction?</p> <p>Is the shelf or dispensing device no higher than 48 inches above the floor?</p>	<p><input type="checkbox"/> Yes <input type="checkbox"/> No Measurement:</p> <p><input type="checkbox"/> Yes <input type="checkbox"/> No Measurement:</p>		<p style="text-align: center; color: red; font-weight: bold;">NA</p> <p>Photo #:</p>	<ul style="list-style-type: none"> • Reconfigure to provide knee space • Lower shelf and/or dispensing device •
<p>2.87 If the obstruction is no less than 20 inches and no greater than 25 inches deep with a forward approach:</p> <p>Does clear floor space extend under the obstruction that is at least the same depth as the obstruction?</p> <p>Is the shelf or dispensing device no higher than 44 inches above the floor?</p>	<p><input type="checkbox"/> Yes <input type="checkbox"/> No Measurement:</p> <p><input type="checkbox"/> Yes <input type="checkbox"/> No Measurement:</p>		<p style="text-align: center; color: red; font-weight: bold;">NA</p> <p>Photo #:</p>	<ul style="list-style-type: none"> • Reconfigure to provide knee space • Lower shelf and/or dispensing device •
<p>2.88 If there is a tray slide, is the top no less than 28 inches and no greater than 34 inches above the floor?</p>	<p><input type="checkbox"/> Yes <input type="checkbox"/> No Measurement:</p>		<p style="text-align: center; color: red; font-weight: bold;">NA</p> <p>Photo #:</p>	<ul style="list-style-type: none"> • Reconfigure • •

The ADA Checklist for Readily Achievable Barrier Removal

Priority 3 – Men's Toilet Rooms



Project **SDDOT Rest Area Improvements**
FHU Reference Number 13-039-01
TSP Project Number 03120855

Building **HIDEWOOD SOUTH**

Location **29S., MRM 160**

Date **09-17-2013 (Inspection)**

Surveyors **Timothy Roach, AIA**
Todd Schultz, PE

Robert King, CPD

Contact Information **TSP – (605) 343-6102**

When toilet rooms are open to the public they should be accessible to people with disabilities.





Institute for Human Centered Design
www.HumanCenteredDesign.org

November 2011



ADA National Network
Questions on the ADA 800-949-4232 voice/tty
www.ADAchecklist.org

Priority 3 – Toilet Rooms		Comments	Possible Solutions
<p>3.1 If toilet rooms are available to the public, is at least one toilet room accessible? (Either one for each sex, or one unisex.)</p>	<input checked="" type="checkbox"/> Yes <input type="checkbox"/> No	<p>Photo #: 3.1</p>	<ul style="list-style-type: none"> • Reconfigure toilet rooms • Combine toilet rooms to create one unisex accessible toilet room •
<p>3.2 Are there signs at inaccessible toilet rooms that give directions to accessible toilet rooms?</p>	<input type="checkbox"/> Yes <input type="checkbox"/> No	 <p>Photo #:</p>	<ul style="list-style-type: none"> • Install signs • •
<p>3.3 If not all toilet rooms are accessible, is there a sign at the accessible toilet room with the International Symbol of Accessibility?</p>	<input type="checkbox"/> Yes <input type="checkbox"/> No	 <p>Photo #:</p>	<ul style="list-style-type: none"> • Install sign • •
<p>Accessible Route (2010 Standards – Chapter 4)</p>			
<p>3.4 Is there a route to the accessible toilet room(s) that does not include the use of stairs?</p>	<input checked="" type="checkbox"/> Yes <input type="checkbox"/> No	<p>Photo #: 3.4</p>	<ul style="list-style-type: none"> • Alter route • •
<p>Is the route accessible? (See Priority 2 Interior Accessible)</p>	<input checked="" type="checkbox"/> Yes <input type="checkbox"/> No		

Route for specifics.)

Signs at Toilet Rooms (2010 Standards – 703)

3.5 Do text characters contrast with their backgrounds?

Yes No

Are text characters raised?

Yes No

Is there Braille?

Yes No

Is the sign mounted:
On the wall on the latch side of the door?

Yes No

Note:

Signs are permitted on the push side of doors with closers and without hold-open devices.

With clear floor space beyond the arc of the door swing between the closed position and 45-degree open position, at least 18 x 18 inches centered on the tactile characters? *

Yes No

Measurement:

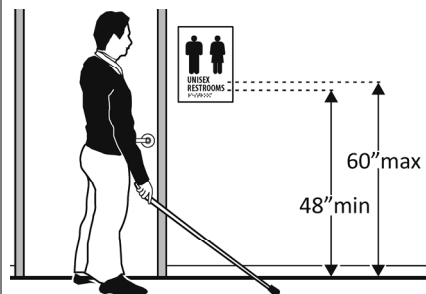
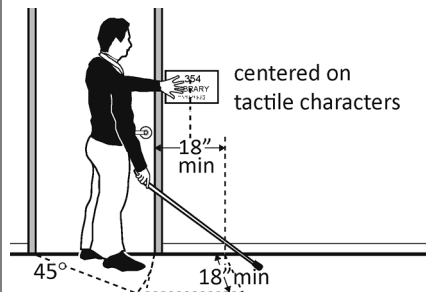
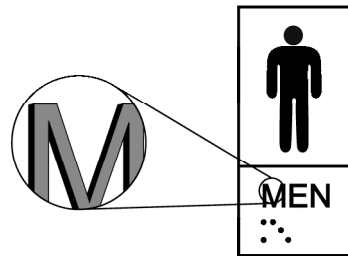
NA

So the baseline of the lowest character is at least 48 inches above the floor and the baseline of the highest character is no more than 60 inches above the floor? *

Yes No

Measurement:

NA



- Install tactile sign
- Relocate sign
-

*If constructed before 3/15/2010 and a person may approach within 3 inches of the sign without encountering protruding objects or standing within the door swing, relocation not required

*If constructed before 3/15/2012 and mounted no higher than 60 inches to the centerline of the sign, relocation is not required

Note:

If the sign is at double doors with one active leaf, the sign should be on the inactive leaf; if both leaves are active, the sign should be on the wall to the right of the right leaf.

Photo #: **3.1**

Entrance (2010 Standards – 404)

3.6 Is the door opening width at least 32 inches clear, between the face of the door and the stop, when the door is open 90 degrees?

Yes No

Measurement:

32"

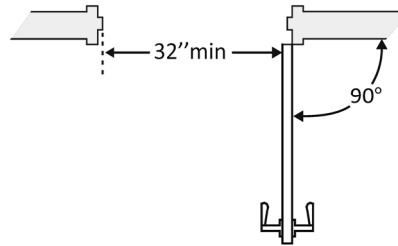


Photo #: **3.6**

- Install offset hinges
- Alter the doorway
-

3.7 If there is a front approach to the pull side of the door is there at least 18 inches of maneuvering clearance beyond the latch side plus 60 inches clear depth?

Yes No

Measurement:

6"

On both sides of the door, is the floor surface of the maneuvering clearance level (no steeper than 1:48)?

Yes No

Measurement:

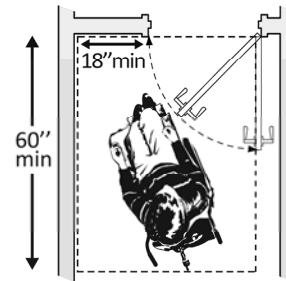
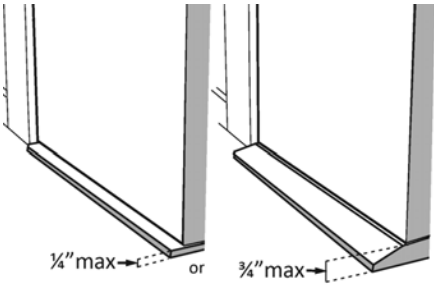
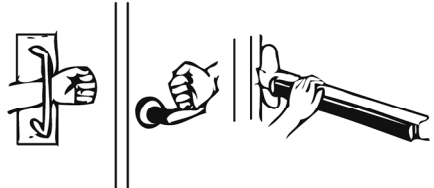
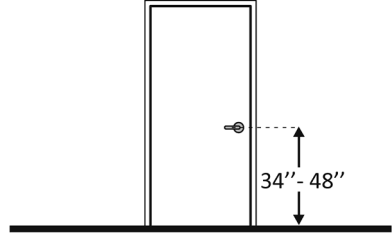

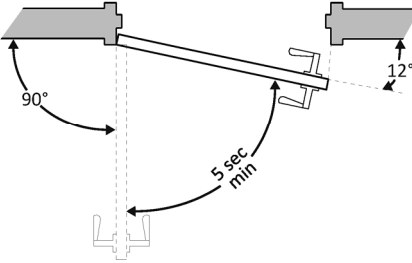
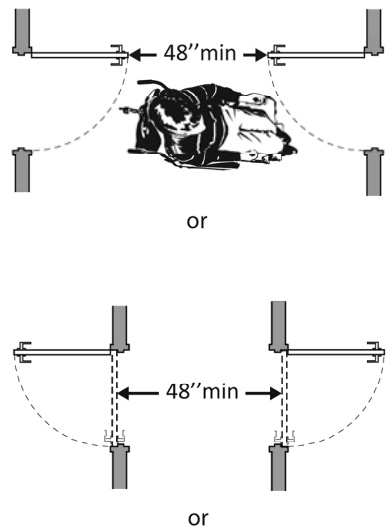


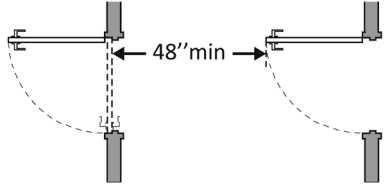
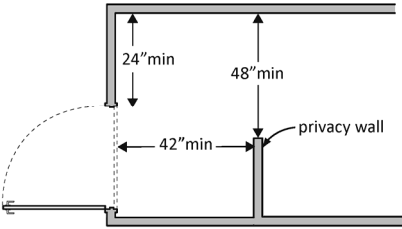
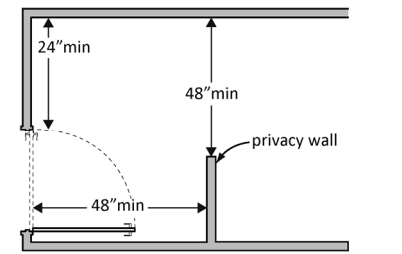

Photo #: **3.1**

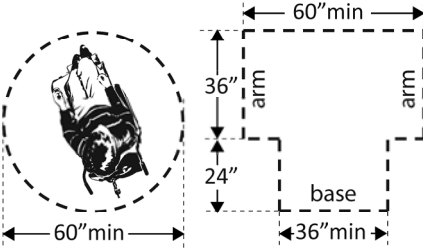
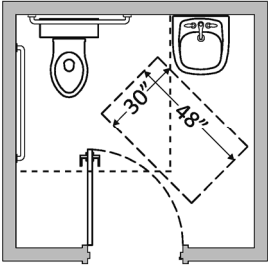
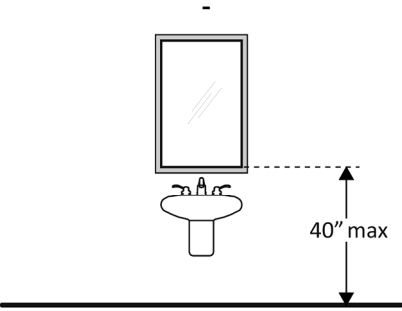
- Remove obstructions
- Reconfigure walls
- Add automatic door opener

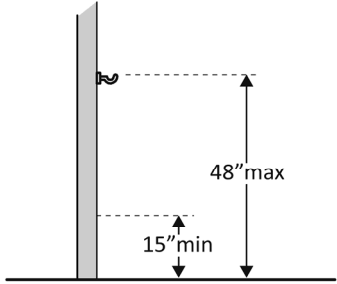
See 2010 Standards 404.2.4 for maneuvering clearance requirements on the push side of the door and side approaches to the pull side of the door

<p>3.8 Is the door threshold edge no more than ¼ inch high?</p> <p>Or</p> <p>No more than ¾ inch high if slope is beveled no steeper than 1:2?</p> <p>Note: The first ¼ inch of the threshold may be vertical; the rest must be beveled.</p>	<p><input type="checkbox"/> Yes <input type="checkbox"/> No</p> <p>Measurement:</p> <p><input type="checkbox"/> Yes <input type="checkbox"/> No</p> <p>Measurement:</p>		<p style="text-align: center;">NA</p> <p>Photo #:</p>	<ul style="list-style-type: none"> • Remove or replace threshold • •
<p>3.9 Is the door equipped with hardware that is operable with one hand and does not require tight grasping, pinching, or twisting of the wrist?</p> <p>Check door handle and lock (if provided).</p>	<p><input checked="" type="checkbox"/> Yes <input type="checkbox"/> No</p> <p>Measurement:</p>		<p>Photo #: 3.9</p>	<ul style="list-style-type: none"> • Replace knobs or latches with lever or loop handles • Install power-assisted or automatic door openers •
<p>3.10 Are the operable parts of the door hardware mounted no less than 34 inches and no greater than 48 inches above the floor?</p>	<p><input type="checkbox"/> Yes <input checked="" type="checkbox"/> No</p> <p>Measurement:</p> <p>32" BOTTOM</p> <p>48" TOP</p>		<p>Photo #: 3.10</p>	<ul style="list-style-type: none"> • Change hardware height • •

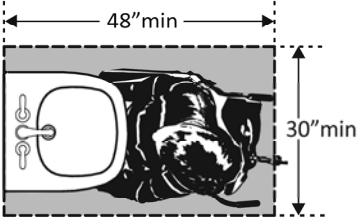
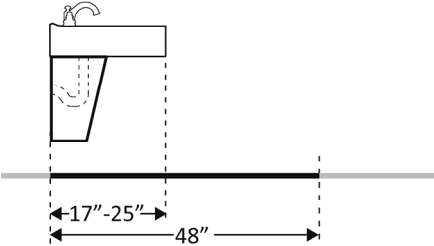
<p>3.11 Can the door be opened easily (5 pounds maximum force)?</p>	<p><input type="checkbox"/> Yes <input checked="" type="checkbox"/> No</p> <p>Measurement:</p> <p>10 LB</p>		<p>Photo #: 3.9</p>	<ul style="list-style-type: none"> • Adjust or replace closers • Install lighter doors • Install power-assisted or automatic door openers
<p>3.12 If the door has a closer, does it take at least 5 seconds to close from an open position of 90 degrees to a position of 12 degrees from the latch?</p>	<p><input type="checkbox"/> Yes <input checked="" type="checkbox"/> No</p> <p>Measurement:</p> <p>4 SEC.</p>		<p>Photo #: 3.9</p>	<ul style="list-style-type: none"> • Adjust closer • •
<p>3.13 If there are two doors in a series, e.g. vestibule, is the distance between the doors at least 48 inches plus the width of the doors when swinging into the space?</p>	<p><input type="checkbox"/> Yes <input type="checkbox"/> No</p> <p>Measurement:</p>		<p>NA</p>	<ul style="list-style-type: none"> • Remove inner door • Change door swing •

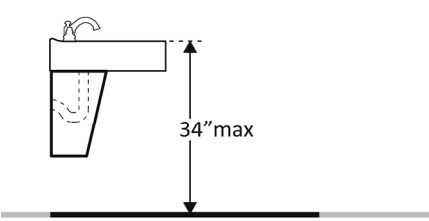
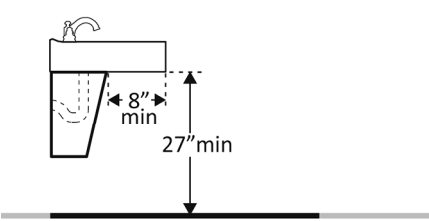
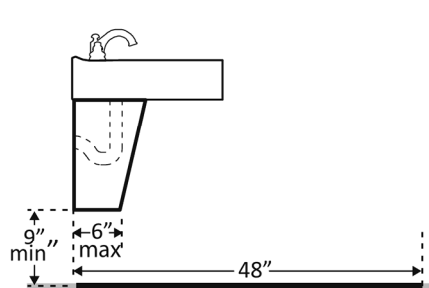
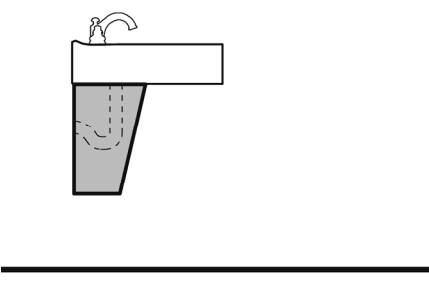
			<p>Photo #:</p>	
<p>3.14 If there is a privacy wall and the door swings out, is there at least 24 inches of maneuvering clearance beyond the door latch side and 42 inches to the privacy wall?</p>	<p><input type="checkbox"/> Yes <input type="checkbox"/> No</p> <p>Measurement:</p>		<p style="text-align: center;">NA</p> <p>Photo #:</p>	<ul style="list-style-type: none"> • Reconfigure space • •
<p>3.15 If there is a privacy wall and the door swings in, is there at least 24 inches of maneuvering clearance beyond the door latch side and at least 48 inches to the privacy wall if there is no door closer or at least 54 inches if there is a door closer?</p>	<p><input type="checkbox"/> Yes <input type="checkbox"/> No</p> <p>Measurement:</p>		<p style="text-align: center;">NA</p> <p>Photo #:</p>	<ul style="list-style-type: none"> • Reconfigure space • •
<p>In the Toilet Room</p>				
<p>3.16 Is there a clear path to at least one of each type of fixture, e.g. lavatory, hand dryer, etc., that is at least 36 inches wide?</p>	<p><input checked="" type="checkbox"/> Yes <input type="checkbox"/> No</p> <p>Measurement:</p> <p style="text-align: center;">44"</p>		<p>Photo #: 3.16</p>	<ul style="list-style-type: none"> • Remove obstructions • •

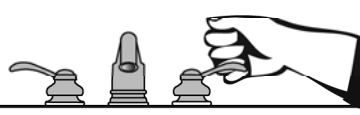
<p>3.17 Is there clear floor space available for a person in a wheelchair to turn around, i.e. a circle at least 60 inches in diameter or a T-shaped space within a 60-inch square?*</p>	<p><input checked="" type="checkbox"/> Yes <input type="checkbox"/> No</p> <p>Measurement: 86" x 106"</p>		<p>Photo #: 3.16</p>	<p>*The door to the toilet room may swing into the required turning space</p> <ul style="list-style-type: none"> • Move or remove partitions, fixtures or objects such as trash cans • •
<p>3.18 In a single user toilet room if the door swings in and over a clear floor space at an accessible fixture, is there a clear floor space at least 30 x 48 inches beyond the swing of the door?</p>	<p><input type="checkbox"/> Yes <input type="checkbox"/> No</p> <p>Measurement:</p>		<p>Photo #: NA</p>	<ul style="list-style-type: none"> • Reverse door swing • Alter toilet room •
<p>3.19 If the mirror is over a lavatory or countertop, is the bottom edge of the reflecting surface no higher than 40 inches above the floor? Or If the mirror is not over the lavatory or countertop, is the bottom edge of the reflecting surface no higher than 35 inches above the floor?*</p>	<p><input checked="" type="checkbox"/> Yes <input type="checkbox"/> No</p> <p>Measurement: 39"</p> <p><input type="checkbox"/> Yes <input type="checkbox"/> No</p> <p>Measurement: NA</p>		<p>Photo #: 3.19</p>	<p>* If installed before 3/15/2012 and the bottom edge of the reflecting surface is no higher than 40 inches above the floor, lowering the mirror to 35 inches is not required</p> <ul style="list-style-type: none"> • Lower the mirror • Add another mirror •

<p>3.20 If there is a coat hook, is it no less than 15 inches and no greater than 48 inches above the floor?</p>	<p><input checked="" type="checkbox"/> Yes <input type="checkbox"/> No</p> <p>Measurement: 46"</p>		<p>Photo #: 3.43</p>	<ul style="list-style-type: none"> • Adjust hook • Replace with or provide additional accessible hook •
---	---	--	-----------------------------	--

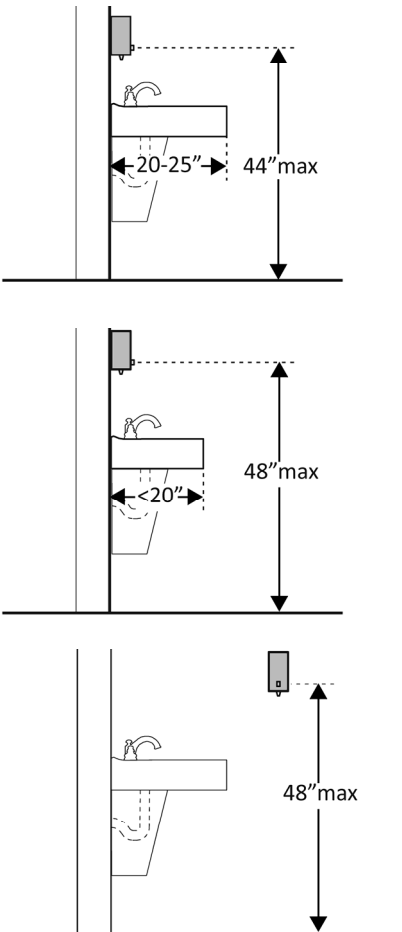
Lavatories (2010 Standards – 606) Note: 2010 Standards refer to sinks in toilet rooms as lavatories.

<p>3.21 Does at least one lavatory have a clear floor space for a forward approach at least 30 inches wide and 48 inches long?</p>	<p><input checked="" type="checkbox"/> Yes <input type="checkbox"/> No</p> <p>Measurement: 30" x 86"</p>		<p>Photo #: 3.19</p>	<ul style="list-style-type: none"> • Alter lavatory • Replace lavatory •
<p>3.22 Do no less than 17 inches and no greater than 25 inches of the clear floor space extend under the lavatory so that a person using a wheelchair can get close enough to reach the faucet?</p>	<p><input checked="" type="checkbox"/> Yes <input type="checkbox"/> No</p> <p>Measurement: 21"</p>		<p>Photo #: 3.23</p>	<ul style="list-style-type: none"> • Alter lavatory • Replace lavatory •

<p>3.23 Is the front of the lavatory or counter surface, whichever is higher, no more than 34 inches above the floor?</p>	<p><input checked="" type="checkbox"/> Yes <input type="checkbox"/> No</p> <p>Measurement:</p> <p>34"</p>		<p>Photo #: 3.23</p>	<ul style="list-style-type: none"> • Alter lavatory • Replace lavatory •
<p>3.24 Is there at least 27 inches clearance from the floor to the bottom of the lavatory that extends at least 8 inches under the lav for knee clearance?</p>	<p><input checked="" type="checkbox"/> Yes <input type="checkbox"/> No</p> <p>Measurement:</p> <p>30"</p>		<p>Photo #: 3.23</p>	<ul style="list-style-type: none"> • Alter lavatory • Replace lavatory •
<p>3.25 Is there toe clearance at least 9 inches high?</p> <p>(Space extending greater than 6 inches beyond the available toe clearance at 9 inches above the floor is not considered toe clearance.)</p>	<p><input checked="" type="checkbox"/> Yes <input type="checkbox"/> No</p> <p>13"</p>		<p>Photo #: 3.23</p>	<ul style="list-style-type: none"> • Alter lavatory • Replace lavatory •
<p>3.26 Are pipes below the lavatory insulated or otherwise configured to protect against contact?</p>	<p><input checked="" type="checkbox"/> Yes <input type="checkbox"/> No</p>		<p>Photo #: 3.23</p>	<ul style="list-style-type: none"> • Install insulation • Install cover panel •

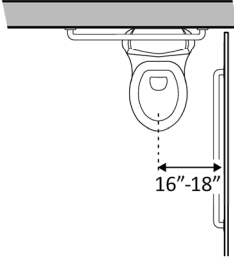
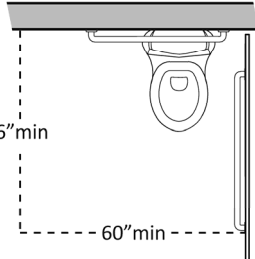
<p>3.27 Can the faucet be operated without tight grasping, pinching, or twisting of the wrist?</p> <p>Is the force required to activate the faucet no greater than 5 pounds?</p>	<p><input checked="" type="checkbox"/> Yes <input type="checkbox"/> No</p> <p><input checked="" type="checkbox"/> Yes <input type="checkbox"/> No</p> <p>1 LB</p>		<p>Photo #: 3.19</p>	<ul style="list-style-type: none"> • Adjust faucet • Replace faucet •
---	--	--	-----------------------------	--

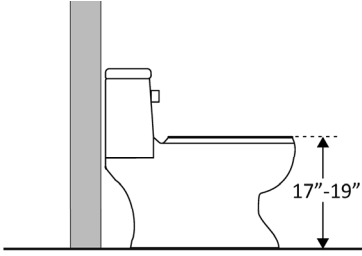
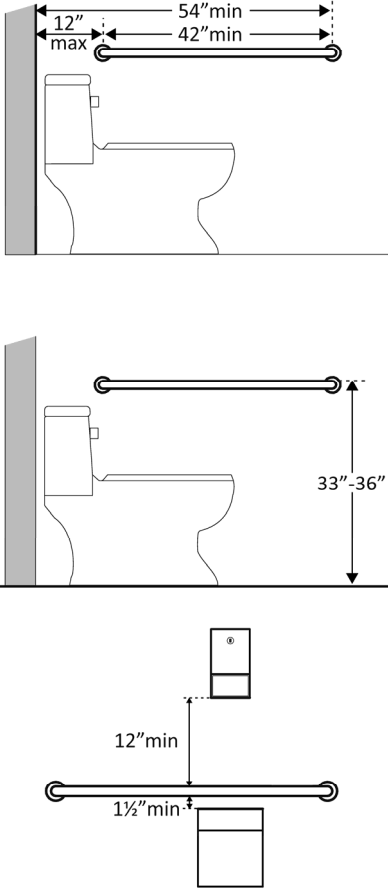
Soap Dispensers and Hand Dryers (2010 Standards – 603)

<p>3.28 Are the operable parts of the soap dispenser within one of the following reach ranges:</p> <p>Above lavatories or counters no less than 20 inches and no greater than 25 inches deep: no higher than 44 inches above the floor?</p> <p>Above lavatories less than 20 inches deep: no higher than 48 inches above the floor?</p> <p>Not over an obstruction: no higher than 48 inches above the floor?</p>	<p><input type="checkbox"/> Yes <input checked="" type="checkbox"/> No</p> <p>Measurement: 49"</p> <p><input type="checkbox"/> Yes <input checked="" type="checkbox"/> No</p> <p>Measurement: 49"</p> <p><input type="checkbox"/> Yes <input type="checkbox"/> No</p> <p>Measurement: NA</p>		<p>Photo #: 3.19</p>	<ul style="list-style-type: none"> • Adjust dispensers • Replace with or provide additional accessible dispensers •
--	---	---	-----------------------------	--

<p>3.29 Are the operable parts of the hand dryer or towel dispenser within one of the following reach ranges:</p> <p>Above lavatories or counters no less than 20 inches and no greater than 25 inches deep: no higher than 44 inches above the floor?</p> <p>Above lavatories less than 20 inches deep: no higher than 48 inches above the floor?</p> <p>Not over an obstruction: no higher than 48 inches above the floor?</p> <p>Can the operable parts of the hand dryer or towel dispenser be operated without tight grasping, pinching or twisting of the wrist?</p> <p>Is the force required to activate the hand dryer or towel dispenser no greater than 5 pounds?</p>	<p><input type="checkbox"/> Yes <input type="checkbox"/> No</p> <p>Measurement: NA</p> <p><input type="checkbox"/> Yes <input type="checkbox"/> No</p> <p>Measurement: NA</p> <p><input checked="" type="checkbox"/> Yes <input type="checkbox"/> No</p> <p>Measurement: 45"</p> <p><input checked="" type="checkbox"/> Yes <input type="checkbox"/> No</p> <p>Measurement: 3lbs</p>		<p>Photo #: 3.19</p>	<ul style="list-style-type: none"> • Adjust dispensers • Replace with or provide additional accessible dispensers •
--	--	--	-----------------------------	--

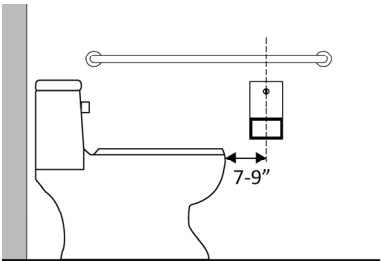
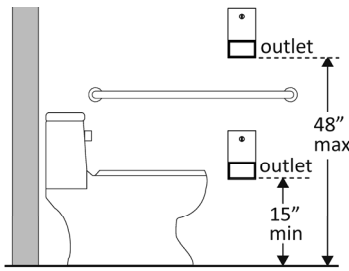
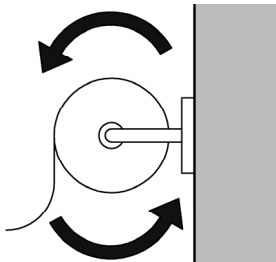
Water Closets in Single-User Toilet Rooms and Compartments (Stalls) (2010 Standards – 603 & 609) Note: 2010 Standards refer to toilets as water closets.

<p>3.30 Is the centerline of the water closet no less than 16 inches and no greater than 18 inches from the side wall or partition?</p>	<p><input checked="" type="checkbox"/> Yes <input type="checkbox"/> No</p> <p>Measurement: 18"</p>		<p>Photo #: 3.30</p>	<ul style="list-style-type: none"> • Move toilet • Replace toilet • Move partition •
<p>3.31 Is clearance provided around the water closet measuring at least 60 inches from the side wall and at least 56 inches from the rear wall?*</p>	<p><input type="checkbox"/> Yes <input checked="" type="checkbox"/> No</p> <p>Measurement: 18"</p>		<p>Photo #: 3.30</p>	<p>* If constructed before 3/15/12, clearances around water closets in single user toilet rooms can be 48 inches wide by 66 inches long or 48 inches wide by 56 inches long (depending on the approach to the water closet, see 1991 Standards Figure 28) and the lavatory may overlap that clearance if the door to the room does not swing into the required clearances at fixtures (such as lavatories, water closet and urinals) and the edge of the lavatory is at least 18 inches from the centerline of the water closet</p> <ul style="list-style-type: none"> • Alter room/compartments for clearance

<p>3.32 Is the height of the water closet no less than 17 inches and no greater than 19 inches above the floor measured to the top of the seat?</p>	<p><input checked="" type="checkbox"/> Yes <input type="checkbox"/> No Measurement: 19"</p>		<p>Photo #: 3.30</p>	<ul style="list-style-type: none"> • Adjust toilet height • Replace toilet •
<p>3.33 Is there a grab bar at least 42 inches long on the side wall?</p> <p>Is it located no more than 12 inches from the rear wall?</p> <p>Does it extend at least 54 inches from the rear wall?</p> <p>Is it mounted no less than 33 inches and no greater than 36 inches above the floor to the top of the gripping surface?</p> <p>Is there at least 12 inches clearance between the grab bar and protruding objects above?*</p> <p>Is there at least 1½ inches clearance between the grab bar and projecting objects below?*</p> <p>Is the space between the wall and the grab bar 1 ½ inches?</p>	<p><input checked="" type="checkbox"/> Yes <input type="checkbox"/> No Measurement: 42"</p> <p><input type="checkbox"/> Yes <input checked="" type="checkbox"/> No Measurement: 13 ½"</p> <p><input checked="" type="checkbox"/> Yes <input type="checkbox"/> No Measurement: 55 ½"</p> <p><input checked="" type="checkbox"/> Yes <input type="checkbox"/> No Measurement: 33"</p> <p><input type="checkbox"/> Yes <input checked="" type="checkbox"/> No Measurement: 8"</p> <p><input checked="" type="checkbox"/> Yes <input type="checkbox"/> No Measurement: NO PROTRUDING OBJECTS BELOW</p> <p><input checked="" type="checkbox"/> Yes <input type="checkbox"/> No</p>		<p>Photo #: 3.30</p>	<ul style="list-style-type: none"> • Install grab bar • Relocate grab bar • Relocate objects • <p>* If constructed before 3/15/2012 grab bars do not need to be relocated; there are no space requirements above and below grab bars in the 1991 Standards</p>

	<p>Measurement: 1 ½"</p>		<p>Photo #: 3.30</p>	
<p>3.34 Is there a grab bar at least 36 inches long on the rear wall?</p> <p>Does it extend at least 12 inches from the centerline of the water closet on one side (side wall)?</p> <p>Does it extend at least 24 inches on the other (open) side?</p> <p>Is it mounted no less than 33 inches and no greater than 36 inches above the floor to the top of the gripping surface?</p> <p>Are there at least 12 inches clearance between the grab bar and protruding objects above?*</p> <p>Are there at least 1½ inches clearance between the grab bar and projecting objects below?*</p> <p>Is the space between the wall and the grab bar 1 ½ inches?</p>	<p><input type="checkbox"/> Yes <input checked="" type="checkbox"/> No</p> <p>Measurement: 30"</p> <p><input checked="" type="checkbox"/> Yes <input type="checkbox"/> No</p> <p>Measurement: 15"</p> <p><input type="checkbox"/> Yes <input checked="" type="checkbox"/> No</p> <p>Measurement: 15"</p> <p><input checked="" type="checkbox"/> Yes <input type="checkbox"/> No</p> <p>Measurement: 33"</p> <p><input checked="" type="checkbox"/> Yes <input type="checkbox"/> No</p> <p>Measurement: NO PROTRUDING OBJECTS BELOW</p> <p><input checked="" type="checkbox"/> Yes <input type="checkbox"/> No</p> <p>Measurement: 13 ½"</p> <p><input checked="" type="checkbox"/> Yes <input type="checkbox"/> No</p>		<p>Photo #: 3.30</p> <p>Photo #: 3.30</p> <p>Photo #: 3.30</p>	<ul style="list-style-type: none"> • Install grab bar • Relocate grab bar • Relocate objects • <p>* If constructed before 3/15/2012 grab bars do not need to be relocated; there are no space requirements above and below grab bars in the 1991 Standards</p>

	<p>Measurement: 1 ½"</p>		<p>Photo #: 3.30</p>	
<p>3.35 If the flush control is hand operated, is the operable part located no higher than 48 inches above the floor?</p>	<p><input checked="" type="checkbox"/> Yes <input type="checkbox"/> No</p> <p>Measurement: 36"</p>		<p>Photo #: 3.30</p>	<ul style="list-style-type: none"> • Move control • Install sensor with override button no higher than 48 inches •
<p>3.36 If the flush control is hand operated, can it be operated with one hand and without tight grasping, pinching, or twisting of the wrist?</p> <p>Is the force required to activate the flush control no greater than 5 pounds?</p>	<p><input checked="" type="checkbox"/> Yes <input type="checkbox"/> No</p> <p><input checked="" type="checkbox"/> Yes <input type="checkbox"/> No</p> <p>Measurement: 1 LB</p>		<p>Photo #: 3.30</p>	<ul style="list-style-type: none"> • Change control • Adjust control •
<p>3.37 Is the flush control on the open side of the water closet?</p>	<p><input type="checkbox"/> Yes <input checked="" type="checkbox"/> No</p>		<p>Photo #: 3.30</p>	<ul style="list-style-type: none"> • Move control • •

<p>3.38 Is the toilet paper dispenser located no less than 7 inches and no greater than 9 inches from the front of the water closet to the centerline of the dispenser?*</p>	<p><input type="checkbox"/> Yes <input checked="" type="checkbox"/> No</p> <p>Measurement:</p> <p>3"</p>		<p>Photo #: 3.41</p> <p>* If constructed before 3/15/2012 dispenser does not need to be relocated if it is within reach from the water closet seat; the 1991 Standards do not specify distance from the front of the water closet</p> <ul style="list-style-type: none"> • Relocate dispenser • •
<p>3.39 Is the outlet of the dispenser:</p> <p>Located no less than 15 inches and no greater than 48 inches above the floor?</p> <p>Not located behind grab bars?</p>	<p><input checked="" type="checkbox"/> Yes <input type="checkbox"/> No</p> <p>Measurement:</p> <p>42"</p> <p><input checked="" type="checkbox"/> Yes <input type="checkbox"/> No</p>		<p>Photo #: 3.41</p> <ul style="list-style-type: none"> • Relocate dispenser • •
<p>3.40 Does the dispenser allow continuous paper flow?</p>	<p><input checked="" type="checkbox"/> Yes <input type="checkbox"/> No</p>		<p>Photo 3.41</p> <ul style="list-style-type: none"> • Adjust dispenser • Replace dispenser •

Toilet Compartments (Stalls) (2010 Standards – 604)

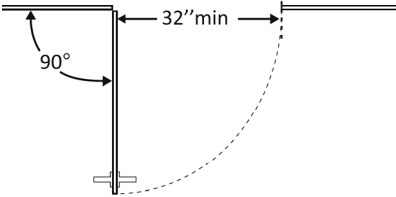
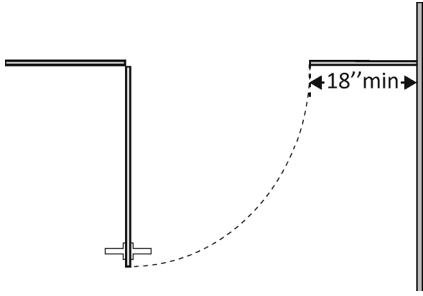
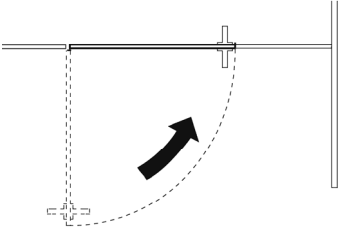
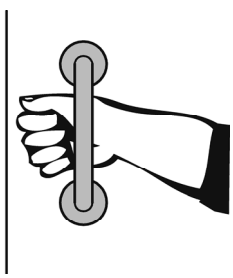
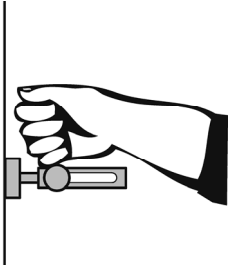
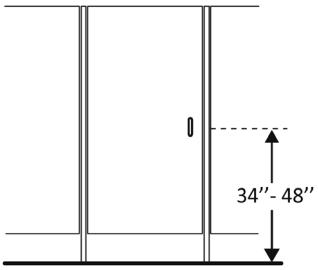
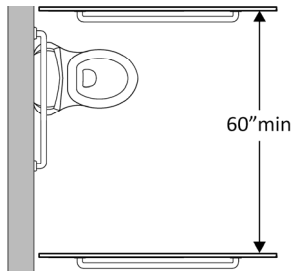
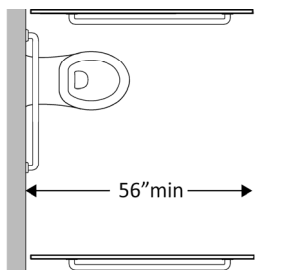
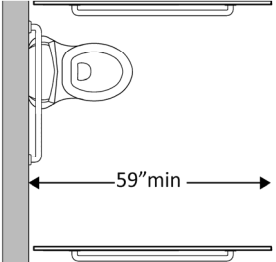
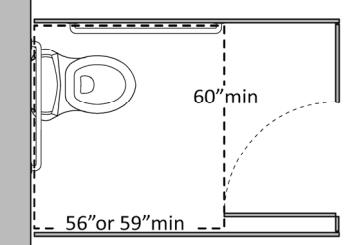
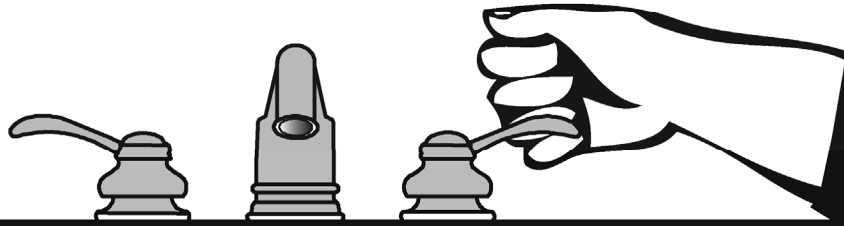
<p>3.41 Is the door opening width at least 32 inches clear, between the face of the door and the stop, when the door is open 90 degrees?</p>	<p><input checked="" type="checkbox"/> Yes <input type="checkbox"/> No</p> <p>Measurement: 32 ½"</p>		<p>Photo #: 3.41</p>	<ul style="list-style-type: none"> • Widen door width • •
<p>3.42 If there is a front approach to the pull side of the door, is there at least 18 inches of maneuvering clearance beyond the latch side plus 60 inches clear depth?*</p>	<p><input type="checkbox"/> Yes <input checked="" type="checkbox"/> No</p> <p>Measurement: 6"</p>		<p>Photo #: 3.41</p>	<p>*See 2010 Standards 604.8.1.2 Doors for maneuvering clearance requirements on the push side of the door and side approaches to the pull side of the door</p> <ul style="list-style-type: none"> • Remove obstructions •
<p>3.43 Is the door self-closing?</p>	<p><input type="checkbox"/> Yes <input checked="" type="checkbox"/> No</p>		<p>Photo #: 3.43</p>	<ul style="list-style-type: none"> • Add closer • Replace door •
<p>3.44 Are there door pulls on both sides of the door that are operable with one hand and do not require tight grasping pinching or twisting of the wrist?*</p>	<p><input checked="" type="checkbox"/> Yes <input type="checkbox"/> No</p>			<p>* If constructed before 3/15/2012 door pulls do not need to be added; door pulls are not required in the 1991 Standards</p> <ul style="list-style-type: none"> • Replace hardware •

			Photo #: 3.43	•
<p>3.45 Is the lock operable with one hand and without tight grasping, pinching or twisting of the wrist?</p>	<p><input checked="" type="checkbox"/> Yes <input type="checkbox"/> No</p>		Photo #: 3.46	<ul style="list-style-type: none"> • Replace lock • •
<p>3.46 Are the operable parts of the door hardware mounted no less than 34 inches and no greater than 48 inches above the floor?</p>	<p><input checked="" type="checkbox"/> Yes <input type="checkbox"/> No</p> <p>Measurement:</p> <p>48"</p>		Photo #: 3.46	<ul style="list-style-type: none"> • Relocate hardware • •
<p>3.47 Is the compartment at least 60 inches wide?</p>	<p><input type="checkbox"/> Yes <input checked="" type="checkbox"/> No</p> <p>Measurement:</p> <p>37"</p>		Photo #: 3.41	<ul style="list-style-type: none"> • Widen compartment • •
<p>3.48 If the water closet is wall hung, is the compartment at least 56 inches deep?</p>	<p><input checked="" type="checkbox"/> Yes <input type="checkbox"/> No</p> <p>Measurement:</p> <p>65"</p>		Photo #: 3.41	<ul style="list-style-type: none"> • Widen compartment • •

<p>3.49 If the water closet is floor mounted, is the compartment at least 59 inches deep?</p>	<p><input type="checkbox"/> Yes <input type="checkbox"/> No</p> <p>Measurement:</p>		<p style="text-align: center; color: red; font-weight: bold;">NA</p> <p>Photo #:</p>	<ul style="list-style-type: none"> • Alter compartment • •
<p>3.50 If the door swings in, is the minimum required compartment area provided beyond the swing of the door (60 inches x 56 inches if water closet is wall hung or 59 inches if water closet is floor mounted)?</p>	<p><input type="checkbox"/> Yes <input type="checkbox"/> No</p> <p>Measurement:</p>		<p style="text-align: center; color: red; font-weight: bold;">NA</p> <p>Photo #:</p>	<ul style="list-style-type: none"> • Reverse door swing • Alter compartment •
	<p><input type="checkbox"/> Yes <input type="checkbox"/> No</p>		<p>Photo #:</p>	<ul style="list-style-type: none"> • • •
	<p><input type="checkbox"/> Yes <input type="checkbox"/> No</p>		<p>Photo #:</p>	<ul style="list-style-type: none"> • • •

The ADA Checklist for Readily Achievable Barrier Removal

Priority 3 – Women’s Toilet Rooms



Project **SDDOT Rest Area Improvements**
FHU Reference Number 13-039-01
TSP Project Number 03120855

Building **HIDEWOOD SOUTH**

Location **29 S., MRM 160**

Date **09-17-2013 (Inspection)**

Surveyors **Timothy Roach, AIA**
Todd Schultz, PE

Robert King, CPD

Contact Information **TSP – (605) 343-6102**



When toilet rooms are open to the public they should be accessible to people with disabilities.



Institute for Human Centered Design
www.HumanCenteredDesign.org
November 2011



ADA National Network
Questions on the ADA 800-949-4232 voice/tty
www.ADAchecklist.org

Priority 3 – Toilet Rooms		Comments	Possible Solutions
<p>3.1 If toilet rooms are available to the public, is at least one toilet room accessible? (Either one for each sex, or one unisex.)</p> <p><input checked="" type="checkbox"/> Yes <input type="checkbox"/> No</p>		Photo #: 3.1	<ul style="list-style-type: none"> • Reconfigure toilet rooms • Combine toilet rooms to create one unisex accessible toilet room
<p>3.2 Are there signs at inaccessible toilet rooms that give directions to accessible toilet rooms?</p> <p><input type="checkbox"/> Yes <input type="checkbox"/> No</p>		<p>NA</p> <p>Photo #:</p>	<ul style="list-style-type: none"> • Install signs • •
<p>3.3 If not all toilet rooms are accessible, is there a sign at the accessible toilet room with the International Symbol of Accessibility?</p> <p><input type="checkbox"/> Yes <input type="checkbox"/> No</p>		<p>NA</p> <p>Photo #:</p>	<ul style="list-style-type: none"> • Install sign • •
<p>Accessible Route (2010 Standards – Chapter 4)</p>			
<p>3.4 Is there a route to the accessible toilet room(s) that does not include the use of stairs?</p> <p><input checked="" type="checkbox"/> Yes <input type="checkbox"/> No</p> <p>Is the route accessible? (See Priority 2 Interior Accessible Route for specifics.)</p> <p><input checked="" type="checkbox"/> Yes <input type="checkbox"/> No</p>		<p>Photo # 3.4:</p>	<ul style="list-style-type: none"> • Alter route • •
<p>Signs at Toilet Rooms (2010 Standards – 703)</p>			

3.5 Do text characters contrast with their backgrounds?

Yes No

Are text characters raised?

Yes No

Is there Braille?

Yes No

Is the sign mounted:
On the wall on the latch side of the door?

Yes No

Note:

Signs are permitted on the push side of doors with closers and without hold-open devices.

With clear floor space beyond the arc of the door swing between the closed position and 45-degree open position, at least 18 x 18 inches centered on the tactile characters? *

Yes No

Measurement:

NA

So the baseline of the lowest character is at least 48 inches above the floor and the baseline of the highest character is no more than 60 inches above the floor? *

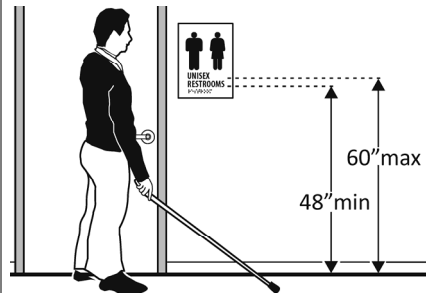
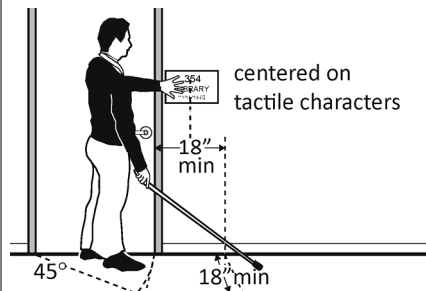
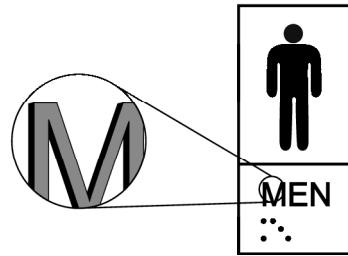
Yes No

Measurement:

NA

Note:

If the sign is at double doors with one active leaf, the sign should be on the inactive leaf; if both leaves are active, the sign should be on the wall to the right of the right leaf.

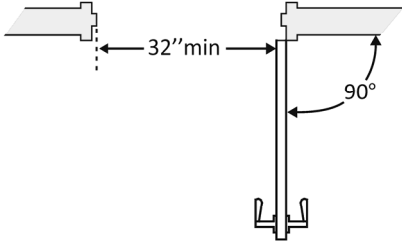
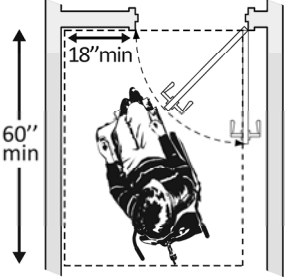
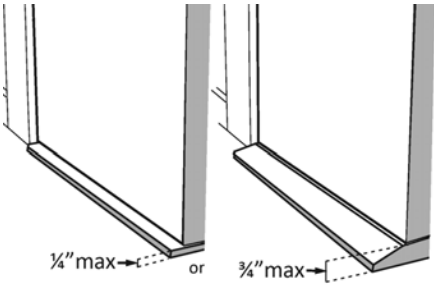


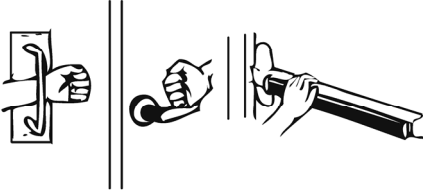
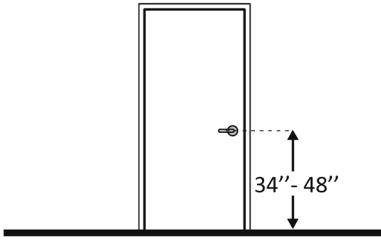

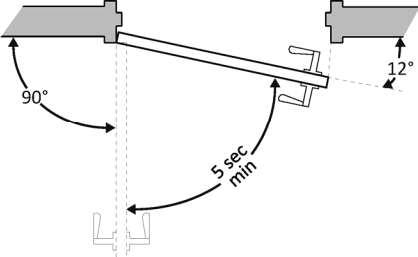
- Install tactile sign
- Relocate sign
-

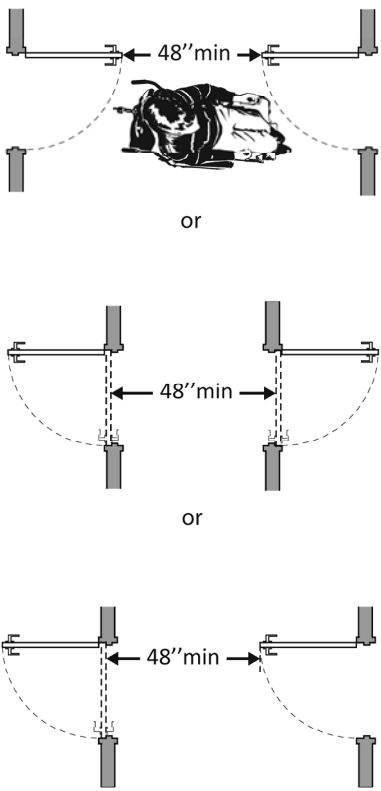
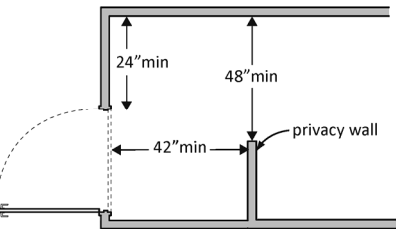
*If constructed before 3/15/2010 and a person may approach within 3 inches of the sign without encountering protruding objects or standing within the door swing, relocation not required

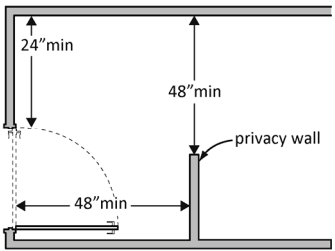

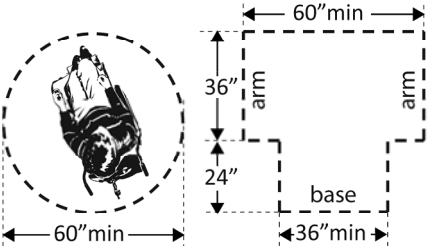
*If constructed before 3/15/2012 and mounted no higher than 60 inches to the centerline of the sign, relocation is not required

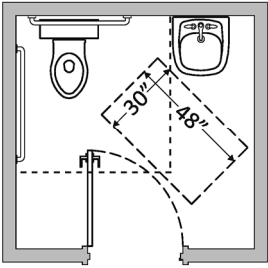
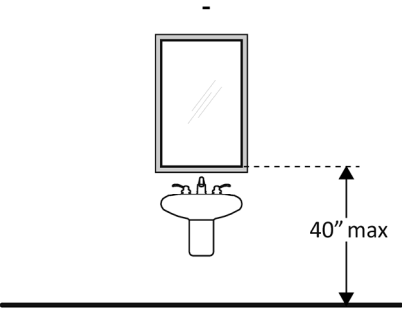
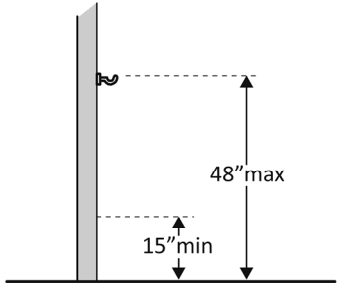
Photo #: 3.1

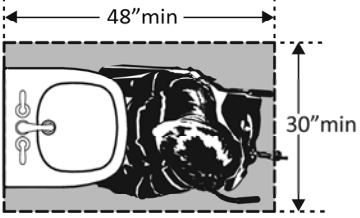
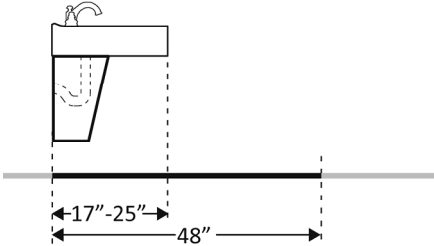
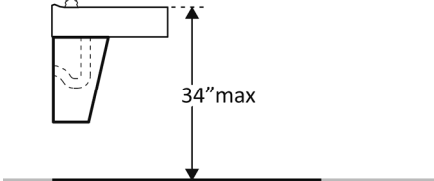
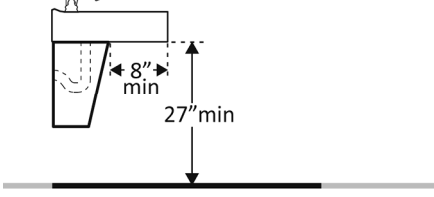
Entrance (2010 Standards – 404)				
<p>3.6 Is the door opening width at least 32 inches clear, between the face of the door and the stop, when the door is open 90 degrees?</p>	<p><input checked="" type="checkbox"/> Yes <input type="checkbox"/> No</p> <p>Measurement: 32"</p>		<p>Photo #: 3.6</p>	<ul style="list-style-type: none"> • Install offset hinges • Alter the doorway •
<p>3.7 If there is a front approach to the pull side of the door is there at least 18 inches of maneuvering clearance beyond the latch side plus 60 inches clear depth?</p> <p>On both sides of the door, is the floor surface of the maneuvering clearance level (no steeper than 1:48)?</p>	<p><input type="checkbox"/> Yes <input checked="" type="checkbox"/> No</p> <p>Measurement: 6"</p> <p><input type="checkbox"/> Yes <input type="checkbox"/> No</p> <p>Measurement:</p>		<p>Photo #: 3.1</p>	<ul style="list-style-type: none"> • Remove obstructions • Reconfigure walls • Add automatic door opener <p>See 2010 Standards 404.2.4 for maneuvering clearance requirements on the push side of the door and side approaches to the pull side of the door</p>
<p>3.8 Is the door threshold edge no more than ¼ inch high?</p> <p>Or</p> <p>No more than ¾ inch high if slope is beveled no steeper than 1:2?</p> <p>Note: The first ¼ inch of the threshold may be vertical; the rest must be beveled.</p>	<p><input type="checkbox"/> Yes <input type="checkbox"/> No</p> <p>Measurement:</p> <p><input type="checkbox"/> Yes <input type="checkbox"/> No</p> <p>Measurement:</p>		<p>NA</p> <p>Photo #:</p>	<ul style="list-style-type: none"> • Remove or replace threshold • •

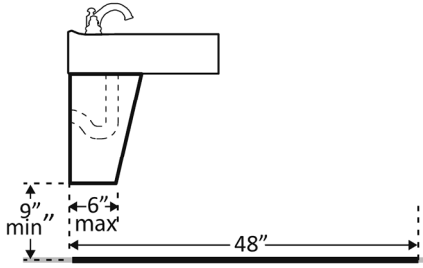
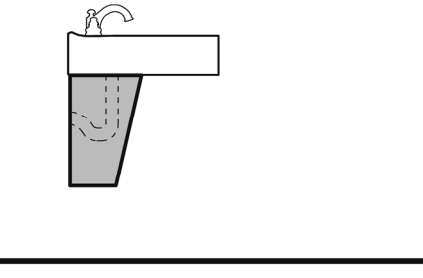
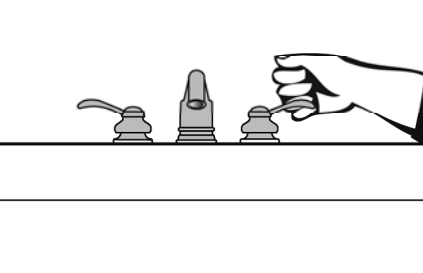
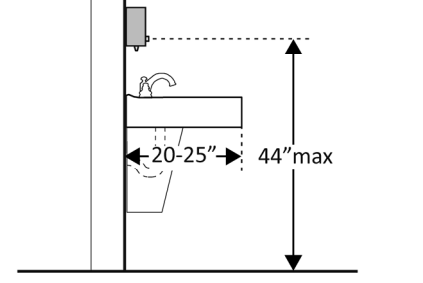
<p>3.9 Is the door equipped with hardware that is operable with one hand and does not require tight grasping, pinching, or twisting of the wrist? Check door handle and lock (if provided).</p>	<p><input checked="" type="checkbox"/> Yes <input type="checkbox"/> No</p> <p>Measurement:</p>		<p>Photo #: 3.9</p>	<ul style="list-style-type: none"> • Replace knobs or latches with lever or loop handles • Install power-assisted or automatic door openers •
<p>3.10 Are the operable parts of the door hardware mounted no less than 34 inches and no greater than 48 inches above the floor?</p>	<p><input checked="" type="checkbox"/> Yes <input type="checkbox"/> No</p> <p>Measurement: 32" Bottom 48" Top</p>		<p>Photo #: 3.10</p>	<ul style="list-style-type: none"> • Change hardware height • •
<p>3.11 Can the door be opened easily (5 pounds maximum force)?</p>	<p><input type="checkbox"/> Yes <input checked="" type="checkbox"/> No</p> <p>Measurement: 6 lbs.</p>		<p>Photo #: 3.10</p>	<ul style="list-style-type: none"> • Adjust or replace closers • Install lighter doors • Install power-assisted or automatic door openers
<p>3.12 If the door has a closer, does it take at least 5 seconds to close from an open position of 90 degrees to a position of 12 degrees from the latch?</p>	<p><input type="checkbox"/> Yes <input checked="" type="checkbox"/> No</p> <p>Measurement: 4 sec.</p>		<p>Photo #: 3.10</p>	<ul style="list-style-type: none"> • Adjust closer • •

<p>3.13 If there are two doors in a series, e.g. vestibule, is the distance between the doors at least 48 inches plus the width of the doors when swinging into the space?</p>	<p><input type="checkbox"/> Yes <input type="checkbox"/> No</p> <p>Measurement:</p>		<p style="text-align: center; color: red; font-weight: bold;">NA</p> <p>Photo #:</p>	<ul style="list-style-type: none"> • Remove inner door • Change door swing •
<p>3.14 If there is a privacy wall and the door swings out, is there at least 24 inches of maneuvering clearance beyond the door latch side and 42 inches to the privacy wall?</p>	<p><input type="checkbox"/> Yes <input type="checkbox"/> No</p> <p>Measurement:</p>		<p style="text-align: center; color: red; font-weight: bold;">NA</p> <p>Photo #:</p>	<ul style="list-style-type: none"> • Reconfigure space • •

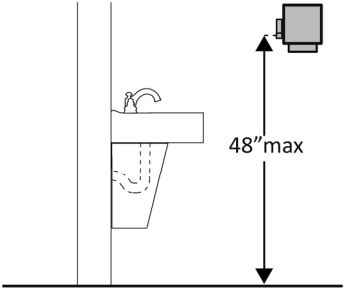
<p>3.15 If there is a privacy wall and the door swings in, is there at least 24 inches of maneuvering clearance beyond the door latch side and at least 48 inches to the privacy wall if there is no door closer or at least 54 inches if there is a door closer?</p>	<p><input type="checkbox"/> Yes <input type="checkbox"/> No</p> <p>Measurement:</p>		<p style="text-align: center; color: red; font-weight: bold;">NA</p> <p>Photo #:</p>	<ul style="list-style-type: none"> • Reconfigure space • •
<p>In the Toilet Room</p>				
<p>3.16 Is there a clear path to at least one of each type of fixture, e.g. lavatory, hand dryer, etc., that is at least 36 inches wide?</p>	<p><input checked="" type="checkbox"/> Yes <input type="checkbox"/> No</p> <p>Measurement:</p> <p style="color: red; font-weight: bold;">44"</p>		<p>Photo #: 3.20</p>	<ul style="list-style-type: none"> • Remove obstructions • •
<p>3.17 Is there clear floor space available for a person in a wheelchair to turn around, i.e. a circle at least 60 inches in diameter or a T-shaped space within a 60-inch square?*</p>	<p><input checked="" type="checkbox"/> Yes <input type="checkbox"/> No</p> <p>Measurement:</p> <p style="color: red; font-weight: bold;">86" x 106"</p>		<p>Photo #: 3.29</p>	<p>*The door to the toilet room may swing into the required turning space</p> <ul style="list-style-type: none"> • Move or remove partitions, fixtures or objects such as trash cans • •

<p>3.18 In a single user toilet room if the door swings in and over a clear floor space at an accessible fixture, is there a clear floor space at least 30 x 48 inches beyond the swing of the door?</p>	<p><input type="checkbox"/> Yes <input type="checkbox"/> No</p> <p>Measurement:</p>		<p style="text-align: center;">NA</p> <p>Photo #:</p>	<ul style="list-style-type: none"> • Reverse door swing • Alter toilet room •
<p>3.19 If the mirror is over a lavatory or countertop, is the bottom edge of the reflecting surface no higher than 40 inches above the floor? Or If the mirror is not over the lavatory or countertop, is the bottom edge of the reflecting surface no higher than 35 inches above the floor?*</p>	<p><input checked="" type="checkbox"/> Yes <input type="checkbox"/> No</p> <p>Measurement:</p> <p style="text-align: center;">39"</p> <p><input type="checkbox"/> Yes <input type="checkbox"/> No</p> <p>Measurement:</p> <p style="text-align: center;">NA</p>		<p>Photo #: 3.23</p>	<p>* If installed before 3/15/2012 and the bottom edge of the reflecting surface is no higher than 40 inches above the floor, lowering the mirror to 35 inches is not required</p> <ul style="list-style-type: none"> • Lower the mirror • Add another mirror •
<p>3.20 If there is a coat hook, is it no less than 15 inches and no greater than 48 inches above the floor?</p>	<p><input checked="" type="checkbox"/> Yes <input type="checkbox"/> No</p> <p>Measurement:</p> <p style="text-align: center;">46"</p>		<p>Photo #: 3.20</p>	<ul style="list-style-type: none"> • Adjust hook • Replace with or provide additional accessible hook •

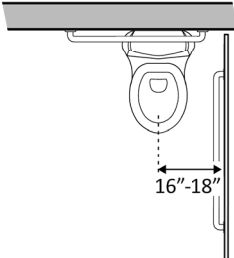
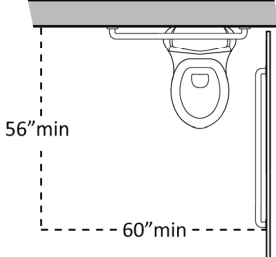
Lavatories (2010 Standards – 606) Note: 2010 Standards refer to sinks in toilet rooms as lavatories.				
<p>3.21 Does at least one lavatory have a clear floor space for a forward approach at least 30 inches wide and 48 inches long?</p>	<p><input checked="" type="checkbox"/> Yes <input type="checkbox"/> No</p> <p>Measurement: 30" X 86"</p>		<p>Photo #: 3.23</p>	<ul style="list-style-type: none"> • Alter lavatory • Replace lavatory •
<p>3.22 Do no less than 17 inches and no greater than 25 inches of the clear floor space extend under the lavatory so that a person using a wheelchair can get close enough to reach the faucet?</p>	<p><input checked="" type="checkbox"/> Yes <input type="checkbox"/> No</p> <p>Measurement: 21"</p>		<p>Photo #: 3.23</p>	<ul style="list-style-type: none"> • Alter lavatory • Replace lavatory •
<p>3.23 Is the front of the lavatory or counter surface, whichever is higher, no more than 34 inches above the floor?</p>	<p><input checked="" type="checkbox"/> Yes <input type="checkbox"/> No</p> <p>Measurement: 34"</p>		<p>Photo #: 3.23</p>	<ul style="list-style-type: none"> • Alter lavatory • Replace lavatory •
<p>3.24 Is there at least 27 inches clearance from the floor to the bottom of the lavatory that extends at least 8 inches under the lav for knee clearance?</p>	<p><input checked="" type="checkbox"/> Yes <input type="checkbox"/> No</p> <p>Measurement: 30"</p>		<p>Photo #: 3.23</p>	<ul style="list-style-type: none"> • Alter lavatory • Replace lavatory •

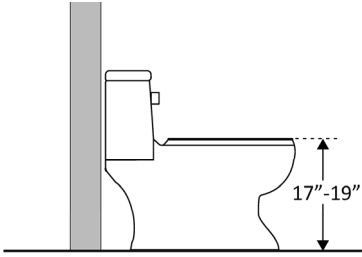
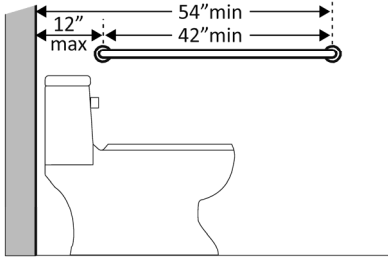
<p>3.25 Is there toe clearance at least 9 inches high? (Space extending greater than 6 inches beyond the available toe clearance at 9 inches above the floor is not considered toe clearance.)</p>	<p><input checked="" type="checkbox"/> Yes <input type="checkbox"/> No 13"</p>		<p>Photo #: 3.23</p>	<ul style="list-style-type: none"> • Alter lavatory • Replace lavatory •
<p>3.26 Are pipes below the lavatory insulated or otherwise configured to protect against contact?</p>	<p><input checked="" type="checkbox"/> Yes <input type="checkbox"/> No</p>		<p>Photo #: 3.23</p>	<ul style="list-style-type: none"> • Install insulation • Install cover panel •
<p>3.27 Can the faucet be operated without tight grasping, pinching, or twisting of the wrist? Is the force required to activate the faucet no greater than 5 pounds?</p>	<p><input checked="" type="checkbox"/> Yes <input type="checkbox"/> No <input checked="" type="checkbox"/> Yes <input type="checkbox"/> No 1 LB</p>		<p>Photo #: 3.23</p>	<ul style="list-style-type: none"> • Adjust faucet • Replace faucet •
<p>Soap Dispensers and Hand Dryers (2010 Standards – 603)</p>				
<p>3.28 Are the operable parts of the soap dispenser within one of the following reach ranges: Above lavatories or counters no less than 20 inches and no greater than 25 inches deep: no higher than 44 inches above the floor?</p>	<p><input type="checkbox"/> Yes <input checked="" type="checkbox"/> No Measurement: 49"</p>		<p>Photo #: 3.23</p>	<ul style="list-style-type: none"> • Adjust dispensers • Replace with or provide additional accessible dispensers •

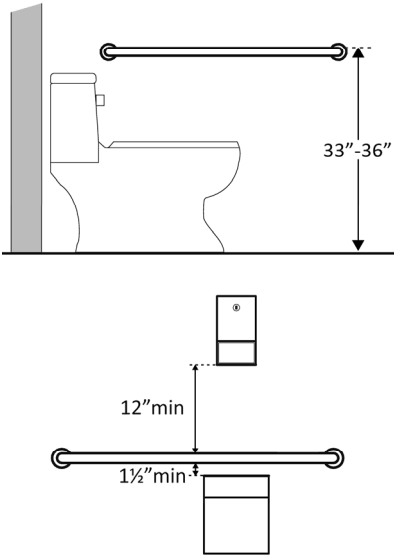
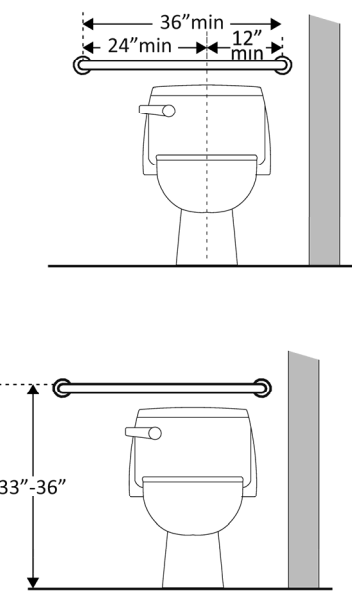
<p>Above lavatories less than 20 inches deep: no higher than 48 inches above the floor?</p> <p>Not over an obstruction: no higher than 48 inches above the floor?</p>	<p><input type="checkbox"/> Yes <input checked="" type="checkbox"/> No</p> <p>Measurement: 49"</p> <p><input type="checkbox"/> Yes <input type="checkbox"/> No</p> <p>Measurement: NA</p>		<p>Photo #: 3.23</p>	
<p>3.29 Are the operable parts of the hand dryer or towel dispenser within one of the following reach ranges:</p> <p>Above lavatories or counters no less than 20 inches and no greater than 25 inches deep: no higher than 44 inches above the floor?</p> <p>Above lavatories less than 20 inches deep: no higher than 48 inches above the floor?</p> <p>Not over an obstruction: no higher than 48 inches above the floor?</p>	<p><input type="checkbox"/> Yes <input type="checkbox"/> No</p> <p>Measurement: NA</p> <p><input type="checkbox"/> Yes <input type="checkbox"/> No</p> <p>Measurement: NA</p> <p><input checked="" type="checkbox"/> Yes <input type="checkbox"/> No</p> <p>Measurement: 45"</p>			<ul style="list-style-type: none"> • Adjust dispensers • Replace with or provide additional accessible dispensers •

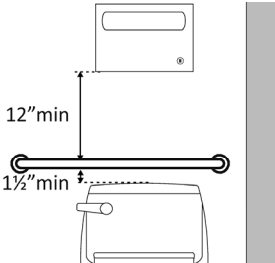
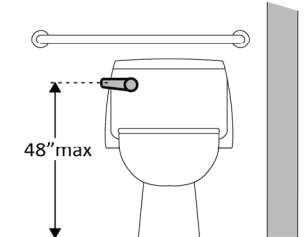
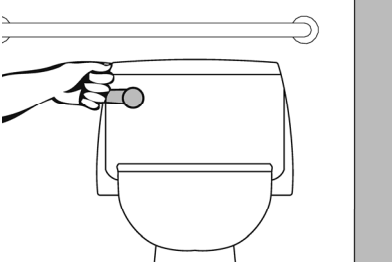
<p>Can the operable parts of the hand dryer or towel dispenser be operated without tight grasping, pinching or twisting of the wrist?</p> <p>Is the force required to activate the hand dryer or towel dispenser no greater than 5 pounds?</p>	<p><input checked="" type="checkbox"/> Yes <input type="checkbox"/> No</p> <p><input checked="" type="checkbox"/> Yes <input type="checkbox"/> No</p> <p>Measurement: 3 LB</p>		<p>Photo #: 3.29</p>	
--	---	--	-----------------------------	--

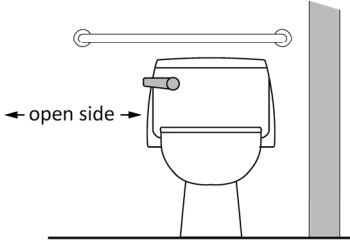
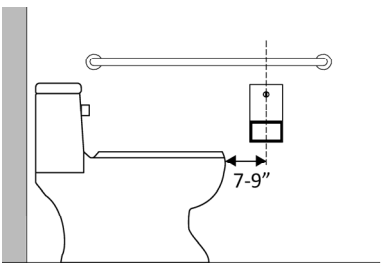
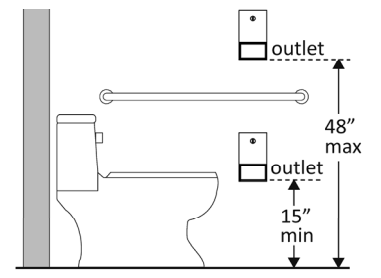
Water Closets in Single-User Toilet Rooms and Compartments (Stalls) (2010 Standards – 603 & 609) Note: 2010 Standards refer to toilets as water closets.

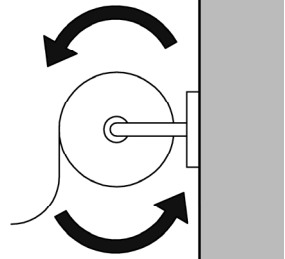
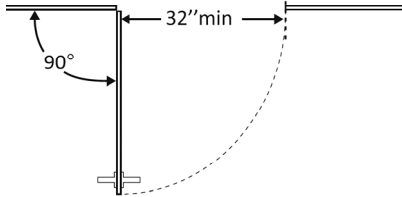
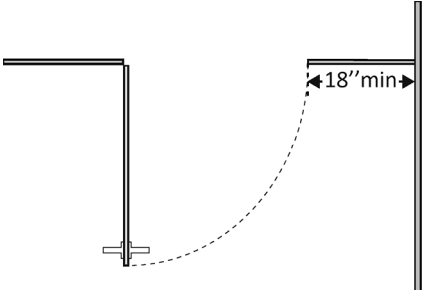
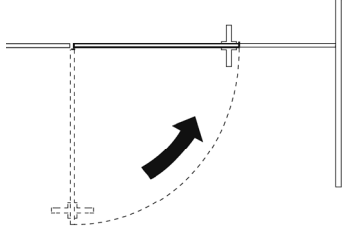
<p>3.30 Is the centerline of the water closet no less than 16 inches and no greater than 18 inches from the side wall or partition?</p>	<p><input checked="" type="checkbox"/> Yes <input type="checkbox"/> No</p> <p>Measurement: 18"</p>		<p>Photo #: 3.30</p>	<ul style="list-style-type: none"> • Move toilet • Replace toilet • Move partition •
<p>3.31 Is clearance provided around the water closet measuring at least 60 inches from the side wall and at least 56 inches from the rear wall?*</p>	<p><input type="checkbox"/> Yes <input checked="" type="checkbox"/> No</p> <p>Measurement: 18"</p>		<p>Photo #: 3.30</p>	<p>* If constructed before 3/15/12, clearances around water closets in single user toilet rooms can be 48 inches wide by 66 inches long or 48 inches wide by 56 inches long (depending on the approach to the water closet, see 1991 Standards Figure 28) and the lavatory may overlap that clearance if the door to the room does not swing into the</p>

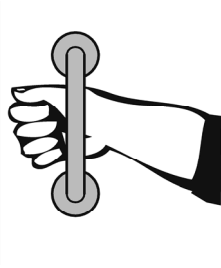
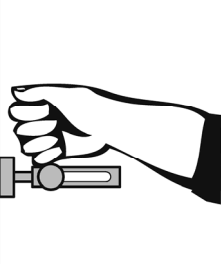
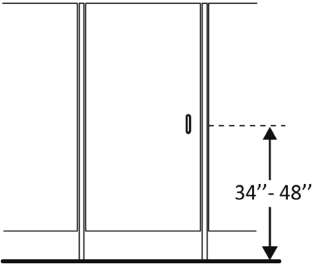
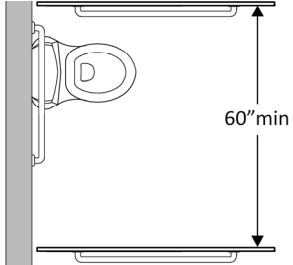
			<p>Photo #: 3.30</p>	<p>required clearances at fixtures (such as lavatories, water closet and urinals) and the edge of the lavatory is at least 18 inches from the centerline of the water closet</p> <ul style="list-style-type: none"> Alter room/compartment for clearance
<p>3.32 Is the height of the water closet no less than 17 inches and no greater than 19 inches above the floor measured to the top of the seat?</p>	<p><input checked="" type="checkbox"/> Yes <input type="checkbox"/> No Measurement: 19"</p>		<p>Photo #: 3.30</p>	<ul style="list-style-type: none"> Adjust toilet height Replace toilet
<p>3.33 Is there a grab bar at least 42 inches long on the side wall?</p> <p>Is it located no more than 12 inches from the rear wall?</p> <p>Does it extend at least 54 inches from the rear wall?</p> <p>Is it mounted no less than 33 inches and no greater than 36 inches above the floor to the top of the gripping surface?</p>	<p><input checked="" type="checkbox"/> Yes <input type="checkbox"/> No Measurement: 42"</p> <p><input type="checkbox"/> Yes <input checked="" type="checkbox"/> No Measurement: 13 ½"</p> <p><input checked="" type="checkbox"/> Yes <input type="checkbox"/> No Measurement: 55 ½"</p> <p><input checked="" type="checkbox"/> Yes <input type="checkbox"/> No Measurement: 33"</p>		<p>Photo #: 3.30</p>	<ul style="list-style-type: none"> Install grab bar Relocate grab bar Relocate objects

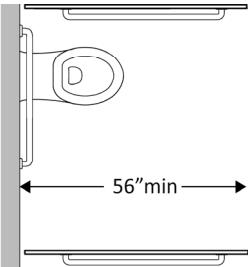
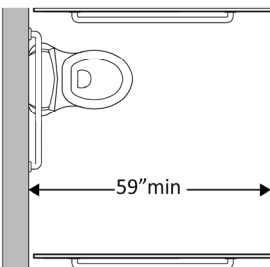
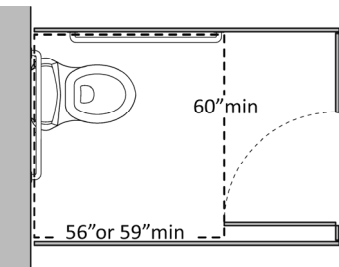
<p>Is there at least 12 inches clearance between the grab bar and protruding objects above?*</p> <p>Is there at least 1½ inches clearance between the grab bar and projecting objects below?*</p> <p>Is the space between the wall and the grab bar 1 ½ inches?</p>	<p><input type="checkbox"/> Yes <input checked="" type="checkbox"/> No Measurement: 8"</p> <p><input checked="" type="checkbox"/> Yes <input type="checkbox"/> No Measurement: NO PROTRUDING OBJECTS BELOW</p> <p><input checked="" type="checkbox"/> Yes <input type="checkbox"/> No Measurement: 1 ½"</p>		<p>Photo #: 3.30</p>	<p>* If constructed before 3/15/2012 grab bars do not need to be relocated; there are no space requirements above and below grab bars in the 1991 Standards</p>
<p>3.34 Is there a grab bar at least 36 inches long on the rear wall?</p> <p>Does it extend at least 12 inches from the centerline of the water closet on one side (side wall)?</p> <p>Does it extend at least 24 inches on the other (open) side?</p> <p>Is it mounted no less than 33 inches and no greater than 36 inches above the floor to the top of the gripping surface?</p> <p>Are there at least 12 inches clearance between the grab bar</p>	<p><input type="checkbox"/> Yes <input checked="" type="checkbox"/> No Measurement: 30"</p> <p><input checked="" type="checkbox"/> Yes <input type="checkbox"/> No Measurement: 15"</p> <p><input type="checkbox"/> Yes <input checked="" type="checkbox"/> No Measurement: 15"</p> <p><input checked="" type="checkbox"/> Yes <input type="checkbox"/> No Measurement: 33"</p> <p><input checked="" type="checkbox"/> Yes <input type="checkbox"/> No</p>		<p>Photo #: 3.30</p> <p>Photo #: 3.30</p>	<ul style="list-style-type: none"> • Install grab bar • Relocate grab bar • Relocate objects •

<p>and protruding objects above?*</p> <p>Are there at least 1½ inches clearance between the grab bar and projecting objects below?*</p> <p>Is the space between the wall and the grab bar 1 ½ inches?</p>	<p>Measurement: TAMPON DISPENSER 4" ABOVE</p> <p><input checked="" type="checkbox"/> Yes <input type="checkbox"/> No</p> <p>Measurement: 13 ½"</p> <p><input checked="" type="checkbox"/> Yes <input type="checkbox"/> No</p> <p>Measurement: 1 ½"</p>		<p>Photo #: 3.30</p>	<p>* If constructed before 3/15/2012 grab bars do not need to be relocated; there are no space requirements above and below grab bars in the 1991 Standards</p>
<p>3.35 If the flush control is hand operated, is the operable part located no higher than 48 inches above the floor?</p>	<p><input checked="" type="checkbox"/> Yes <input type="checkbox"/> No</p> <p>Measurement: 36"</p>		<p>Photo #: 3.30</p>	<ul style="list-style-type: none"> • Move control • Install sensor with override button no higher than 48 inches •
<p>3.36 If the flush control is hand operated, can it be operated with one hand and without tight grasping, pinching, or twisting of the wrist?</p> <p>Is the force required to activate the flush control no greater than 5 pounds?</p>	<p><input checked="" type="checkbox"/> Yes <input type="checkbox"/> No</p> <p><input checked="" type="checkbox"/> Yes <input type="checkbox"/> No</p> <p>Measurement: 1 LB</p>		<p>Photo #: 3.30</p>	<ul style="list-style-type: none"> • Change control • Adjust control •

<p>3.37 Is the flush control on the open side of the water closet?</p>	<p><input type="checkbox"/> Yes <input checked="" type="checkbox"/> No</p>		<p>Photo #: 3.30</p>	<ul style="list-style-type: none"> • Move control • •
<p>3.38 Is the toilet paper dispenser located no less than 7 inches and no greater than 9 inches from the front of the water closet to the centerline of the dispenser?*</p>	<p><input type="checkbox"/> Yes <input checked="" type="checkbox"/> No</p> <p>Measurement:</p> <p>3"</p>		<p>Photo #: 3.30</p>	<p>* If constructed before 3/15/2012 dispenser does not need to be relocated if it is within reach from the water closet seat; the 1991 Standards do not specify distance from the front of the water closet</p> <ul style="list-style-type: none"> • Relocate dispenser • •
<p>3.39 Is the outlet of the dispenser:</p> <p>Located no less than 15 inches and no greater than 48 inches above the floor?</p> <p>Not located behind grab bars?</p>	<p><input checked="" type="checkbox"/> Yes <input type="checkbox"/> No</p> <p>Measurement:</p> <p>42"</p> <p><input type="checkbox"/> Yes <input type="checkbox"/> No</p>		<p>Photo #: 3.30</p>	<ul style="list-style-type: none"> • Relocate dispenser • •

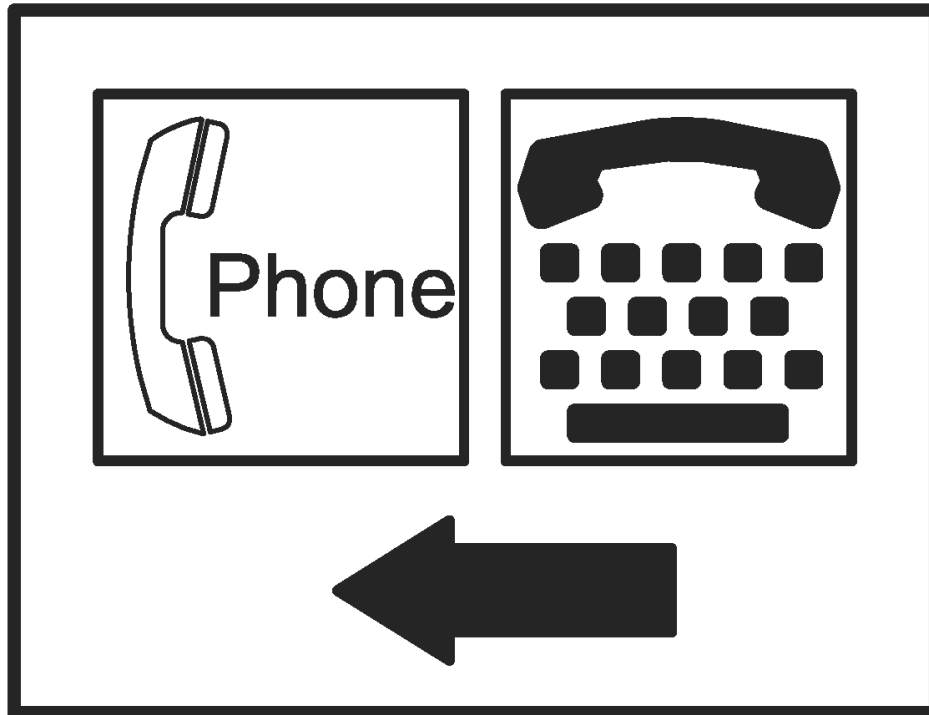
<p>3.40 Does the dispenser allow continuous paper flow?</p>	<p><input checked="" type="checkbox"/> Yes <input type="checkbox"/> No</p>		<p>Photo #: 3.30</p>	<ul style="list-style-type: none"> • Adjust dispenser • Replace dispenser •
<p>Toilet Compartments (Stalls) (2010 Standards – 604)</p>				
<p>3.41 Is the door opening width at least 32 inches clear, between the face of the door and the stop, when the door is open 90 degrees?</p>	<p><input checked="" type="checkbox"/> Yes <input type="checkbox"/> No</p> <p>Measurement: 32 ½"</p>		<p>Photo #: 3.41</p>	<ul style="list-style-type: none"> • Widen door width • •
<p>3.42 If there is a front approach to the pull side of the door, is there at least 18 inches of maneuvering clearance beyond the latch side plus 60 inches clear depth?*</p>	<p><input type="checkbox"/> Yes <input checked="" type="checkbox"/> No</p> <p>Measurement: 6"</p>		<p>Photo #: 3.42</p>	<p>*See 2010 Standards 604.8.1.2 Doors for maneuvering clearance requirements on the push side of the door and side approaches to the pull side of the door</p> <ul style="list-style-type: none"> • Remove obstructions •
<p>3.43 Is the door self-closing?</p>	<p><input type="checkbox"/> Yes <input checked="" type="checkbox"/> No</p>		<p>Photo #: 3.20</p>	<ul style="list-style-type: none"> • Add closer • Replace door •

<p>3.44 Are there door pulls on both sides of the door that are operable with one hand and do not require tight grasping pinching or twisting of the wrist?*</p>	<p><input checked="" type="checkbox"/> Yes <input type="checkbox"/> No</p>		<p>Photo #: 3.44</p>	<p>* If constructed before 3/15/2012 door pulls do not need to be added; door pulls are not required in the 1991 Standards</p> <ul style="list-style-type: none"> • Replace hardware • •
<p>3.45 Is the lock operable with one hand and without tight grasping, pinching or twisting of the wrist?</p>	<p><input checked="" type="checkbox"/> Yes <input type="checkbox"/> No</p>		<p>Photo #: 3.44</p>	<ul style="list-style-type: none"> • Replace lock • •
<p>3.46 Are the operable parts of the door hardware mounted no less than 34 inches and no greater than 48 inches above the floor?</p>	<p><input checked="" type="checkbox"/> Yes <input type="checkbox"/> No</p> <p>Measurement: 48"</p>		<p>Photo #: 3.46</p>	<ul style="list-style-type: none"> • Relocate hardware • •
<p>3.47 Is the compartment at least 60 inches wide?</p>	<p><input type="checkbox"/> Yes <input checked="" type="checkbox"/> No</p> <p>Measurement: 37"</p>		<p>Photo #: 3.20</p>	<ul style="list-style-type: none"> • Widen compartment • •

<p>3.48 If the water closet is wall hung, is the compartment at least 56 inches deep?</p>	<p><input checked="" type="checkbox"/> Yes <input type="checkbox"/> No</p> <p>Measurement: 65"</p>		<p>Photo #: 3.20</p>	<ul style="list-style-type: none"> • Widen compartment • •
<p>3.49 If the water closet is floor mounted, is the compartment at least 59 inches deep?</p>	<p><input type="checkbox"/> Yes <input type="checkbox"/> No</p> <p>Measurement:</p>		<p>Photo #: NA</p>	<ul style="list-style-type: none"> • Alter compartment • •
<p>3.50 If the door swings in, is the minimum required compartment area provided beyond the swing of the door (60 inches x 56 inches if water closet is wall hung or 59 inches if water closet is floor mounted)?</p>	<p><input type="checkbox"/> Yes <input type="checkbox"/> No</p> <p>Measurement:</p>		<p>Photo #: NA</p>	<ul style="list-style-type: none"> • Reverse door swing • Alter compartment •
<p></p>	<p><input type="checkbox"/> Yes <input type="checkbox"/> No</p>	<p></p>	<p>Photo #:</p>	<ul style="list-style-type: none"> • • •
<p></p>	<p><input type="checkbox"/> Yes <input type="checkbox"/> No</p>	<p></p>	<p>Photo #:</p>	<ul style="list-style-type: none"> • • •

ADA Checklist for Readily Achievable Barrier Removal

Priority 4 – Additional Access



Project **SDDOT Rest Area Improvements**

FHU Reference Number 13-039-01

TSP Project Number 03120855

Building **HIDEWOOD SOUTH**

Location **29 S., MRM 160**

Date **09-17-2013 (Inspection)**

Surveyors **Timothy Roach, AIA**

Todd Schultz, PE

Robert King, CPD

Contact Information **TSP – (605) 343-6102**

Amenities such as drinking fountains and public telephones should be accessible to people with disabilities.



Institute for Human Centered Design

www.HumanCenteredDesign.org

November 2011



ADA National Network

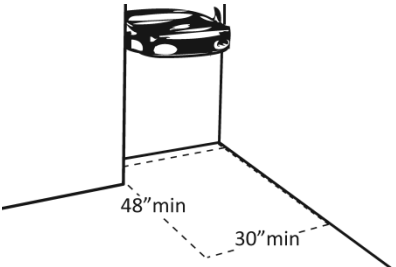
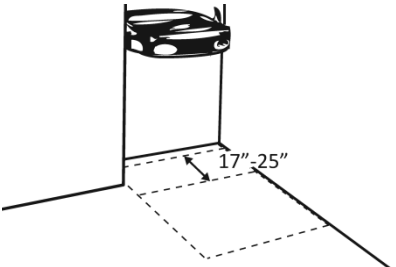
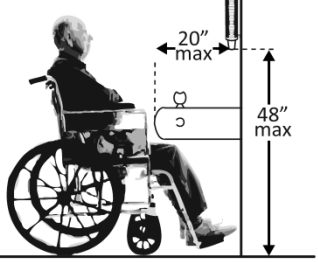
Questions on the ADA 800-949-4232 voice/tty

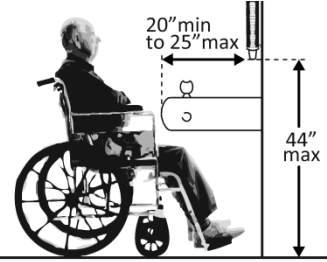

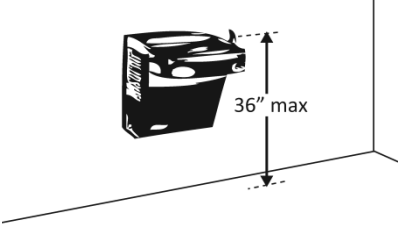
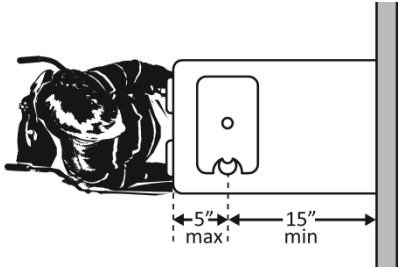
www.ADAchecklist.org

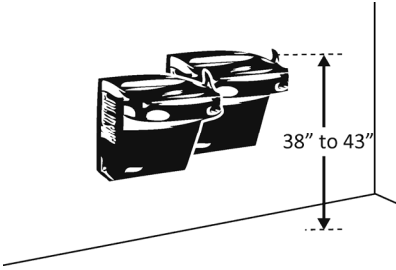
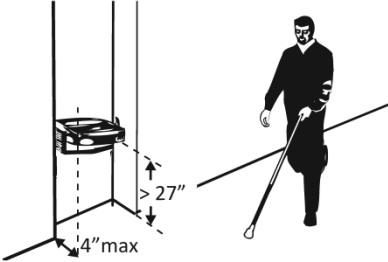
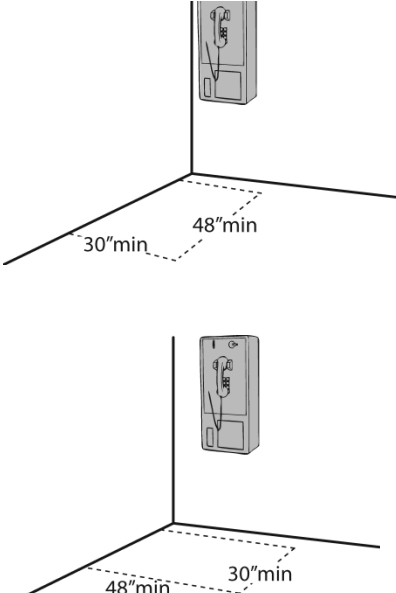
This checklist was produced by the New England ADA Center, a project of the Institute for Human Centered Design and a member of the ADA National Network. This checklist was developed under a grant from the Department of Education, NIDRR grant number H133A060092-09A. However the contents do not necessarily represent the policy of the Department of Education, and you should not assume endorsement by the Federal Government.

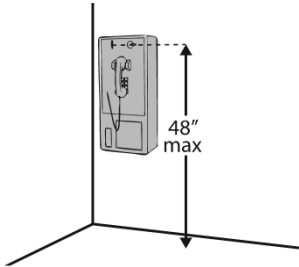
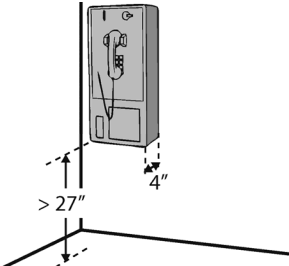


Questions or comments on the checklist contact the New England ADA Center at 617-695-0085 voice/tty or ADAinfo@NewEnglandADA.org




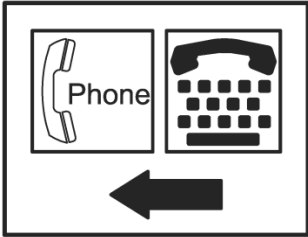
For the full set of checklists, including the checklists for recreation facilities visit www.ADAchecklist.org.

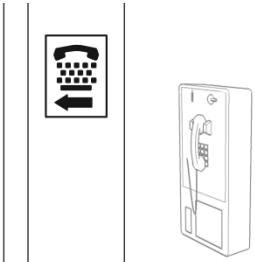
Priority 4 – Additional Access		Comments	Possible Solutions
Drinking Fountains (2010 Standards – 602)			
<p>4.1 Does at least one drinking fountain have a clear floor space at least 30 inches wide x at least 48 inches long centered in front of it for a forward approach?*</p>	<p><input checked="" type="checkbox"/> Yes <input type="checkbox"/> No</p> <p>Measurement: 48 X 30</p>		<p>Photo #: 4.7</p> <p>*If installed before 3/15/2012, a parallel approach is permitted and the clear floor space is not required to be centered</p> <ul style="list-style-type: none"> • Alter space • Relocate drinking fountain • Install a drinking fountain in another location
<p>4.2 If there is a forward approach, do no less than 17 inches and no greater than 25 inches of the clear floor space extend under the drinking fountain?</p>	<p><input type="checkbox"/> Yes <input type="checkbox"/> No</p> <p>Measurement: 19"</p>		<p>Photo #: 4.7</p> <ul style="list-style-type: none"> • Alter space • Replace drinking fountain •
<p>4.3 If the drinking fountain is no deeper than 20 inches, are the operable parts no higher than 48 inches above the floor?</p>	<p><input type="checkbox"/> Yes <input type="checkbox"/> No</p> <p>Measurement: 30"</p>		<p>Photo #: 4.6</p> <ul style="list-style-type: none"> • Adjust drinking fountain • Replace drinking fountain •

<p>4.4 If the drinking fountain is no less than 20 inches and no greater than 25 inches deep, are the operable parts no higher than 44 inches above the floor?</p>	<p><input type="checkbox"/> Yes <input type="checkbox"/> No Measurement:</p>		<p style="text-align: center;">NA</p> <p>Photo #:</p>	<ul style="list-style-type: none"> • Adjust drinking fountain • Replace drinking fountain •
<p>4.5 Can the control be operated with one hand and without tight grasping, pinching or twisting of the wrist?</p> <p>Is the force required to activate the control no more than 5 pounds?</p>	<p><input checked="" type="checkbox"/> Yes <input type="checkbox"/> No Measurement:</p> <p>1 LB</p>		<p>Photo #: 4.8</p>	<ul style="list-style-type: none"> • Change control • Adjust control •
<p>4.6 Is the spout outlet no higher than 36 inches above the floor?</p>	<p><input checked="" type="checkbox"/> Yes <input type="checkbox"/> No Measurement:</p> <p>36"</p>		<p>Photo #: 4.6</p>	<ul style="list-style-type: none"> • Adjust drinking fountain • Replace drinking fountain •
<p>4.7 Is the spout:</p> <p>At least 15 inches from the rear of the drinking fountain?</p> <p>No more than 5 inches from the front of the drinking fountain?</p>	<p><input checked="" type="checkbox"/> Yes <input type="checkbox"/> No Measurement:</p> <p>16"</p> <p><input checked="" type="checkbox"/> Yes <input type="checkbox"/> No Measurement:</p> <p>3"</p>		<p>Photo #: 4.8</p>	<ul style="list-style-type: none"> • Adjust spout • Replace drinking fountain •


<p>4.8 If there is more than one drinking fountain, is there at least one for standing persons?</p> <p>Is the spout outlet no lower than 38 inches and no higher than 43 inches above the floor?</p>	<p><input checked="" type="checkbox"/> Yes <input type="checkbox"/> No</p> <p><input checked="" type="checkbox"/> Yes <input type="checkbox"/> No</p> <p>Measurement: 36"</p>		<p>Photo #: 4.6</p>	<ul style="list-style-type: none"> • Adjust drinking fountain • Install new drinking fountain for standing height •
<p>4.9 If the leading (bottom) edge of the fountain is higher than 27 inches above the floor, does the front of the fountain protrude no more than 4 inches into the circulation path?</p>	<p><input type="checkbox"/> Yes <input type="checkbox"/> No</p> <p>Measurement:</p>		<p>Photo #: NA</p>	<ul style="list-style-type: none"> • Adjust drinking fountain • Replace drinking fountain • Add tactile warning such as permanent planter or partial walls
<p>Public Telephones (2010 Standards – 704) TTY's are devices that employ interactive text-based communication through the transmission of coded signals across the telephone network. They are mainly used by people who are deaf and/or cannot speak.</p>				
<p>4.10 Does at least one telephone have a clear floor space at least 30 inches wide x at least 48 inches long for a parallel or forward approach?</p>	<p><input checked="" type="checkbox"/> Yes <input type="checkbox"/> No</p> <p>30" X 48"</p>		<p>Photo 4.12</p>	<ul style="list-style-type: none"> • Move telephone • Install new telephone for clear floor space •

<p>4.11 Is the highest operable part of the telephone no higher than 48 inches above the floor?</p>	<p><input type="checkbox"/> Yes <input checked="" type="checkbox"/> No</p> <p>Measurement: 51" TO COIN SLOT</p>		<p>Photo #: 4.12</p>	<ul style="list-style-type: none"> • Adjust telephone • •
<p>4.12 If the leading (bottom) edge of the telephone is higher than 27 inches above the floor, does the front of the telephone protrude no more than 4 inches into the circulation path?</p>	<p><input checked="" type="checkbox"/> Yes <input type="checkbox"/> No</p> <p>Measurement: 32 ½" ABOVE FLOOR 8" WALL</p>		<p>Photo #: 4.12</p>	<ul style="list-style-type: none"> • Adjust telephone • •
<p>4.13 Does at least one telephone have a volume control?</p>	<p><input type="checkbox"/> Yes <input checked="" type="checkbox"/> No</p>		<p>Photo #: 4.12</p>	<ul style="list-style-type: none"> • Install volume control • Replace telephone with one that has volume control •
<p>4.14 Is the volume control identified by a pictogram of a telephone handset with radiating sound waves?</p>	<p><input type="checkbox"/> Yes <input checked="" type="checkbox"/> No</p>		<p>Photo #: 4.12</p>	<ul style="list-style-type: none"> • Add pictogram • •

<p>4.15 Does at least one telephone have a TTY?</p>	<p><input type="checkbox"/> Yes <input type="checkbox"/> No</p>		<p style="text-align: center;">NA</p> <p>Photo #:</p>	<ul style="list-style-type: none"> • Install TTY • •
<p>4.16 Is the touch surface of the TTY keypad at least 34 inches above the floor?</p>	<p><input type="checkbox"/> Yes <input type="checkbox"/> No</p> <p>Measurement:</p>		<p style="text-align: center;">NA</p> <p>Photo #:</p>	<ul style="list-style-type: none"> • If a seat is provided, TTY is not required to be 34 inches minimum above the floor • Adjust height of TTY •
<p>4.17 Is the TTY identified by the International Symbol of TTY?</p>	<p><input type="checkbox"/> Yes <input type="checkbox"/> No</p>		<p style="text-align: center;">NA</p> <p>Photo #:</p>	<ul style="list-style-type: none"> • Add symbol • •
<p>4.18 Do signs that provide direction to public telephones also provide direction to the TTY?</p>	<p><input type="checkbox"/> Yes <input type="checkbox"/> No</p>		<p style="text-align: center;">NA</p> <p>Photo #:</p>	<ul style="list-style-type: none"> • Add signs • •

<p>4.19 Do telephones that do not have a TTY provide direction to the TTY?</p>	<input type="checkbox"/> Yes <input type="checkbox"/> No		<p style="text-align: center;">NA</p> <p>Photo #:</p>	<ul style="list-style-type: none"> • Add signs • •
---	--	--	--	---

Fire Alarm Systems (2010 Standards – 702)

<p>4.20 If there are fire alarm systems, do they have both flashing lights and audible signals?</p>	<input type="checkbox"/> Yes <input type="checkbox"/> No		<p style="text-align: center;">NA</p> <p>Photo #:</p>	<ul style="list-style-type: none"> • Install audible and visual alarms • •
	<input type="checkbox"/> Yes <input type="checkbox"/> No		<p>Photo #:</p>	<ul style="list-style-type: none"> • • •
	<input type="checkbox"/> Yes <input type="checkbox"/> No		<p>Photo #:</p>	<ul style="list-style-type: none"> • • •
	<input type="checkbox"/> Yes <input type="checkbox"/> No		<p>Photo #:</p>	<ul style="list-style-type: none"> • • •

HIDEWOOD SOUTH PRIORITY 1



Photo #1.1



Photo #1.10



Photo #1.13



Photo #1.41

HIDEWOOD SOUTH PRIORITY 1



Photo #1.42



Photo #1.43

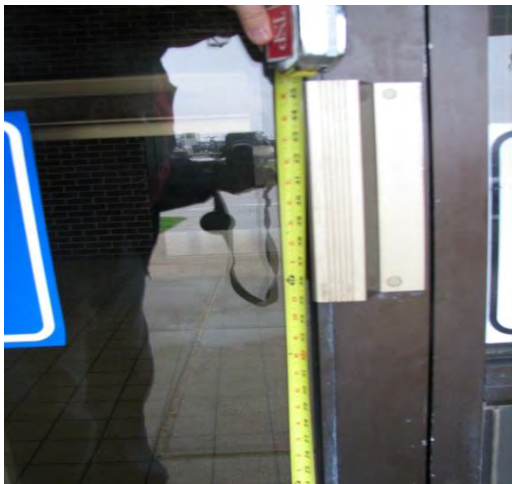


Photo # 1.45



Photo #1.46

HIDEWOOD SOUTH PRIORITY 2



Photo #2.1



Photo #2.4



Photo #2.8



Photo #2.38

HIDEWOOD SOUTH PRIORITY 2



Photo # 2.68

HIDEWOOD SOUTH PRIORITY 3 – MEN'S



Photo #3.1



Photo #3.4



Photo #3.6



Photo #3.9

HIDEWOOD SOUTH PRIORITY 3 – MEN'S



Photo #3.10



Photo # 3.16



Photo #3.19



Photo # 3.23

HIDEWOOD SOUTH PRIORITY 3 – MEN'S



Photo # 3.30



Photo # 3.41



Photo # 3.43



Photo #3.46

HIDEWOOD SOUTH PRIORITY 3 – MEN'S



Photo # 3.47

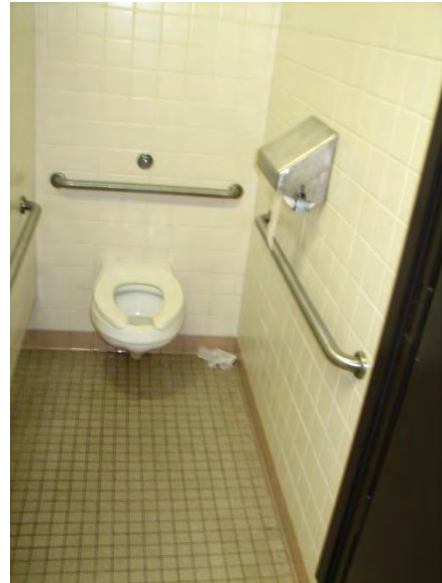


Photo # 3.48

HIDEWOOD SOUTH PRIORITY 3 – WOMEN'S



Photo #3.1



Photo #3.4



Photo #3.6



Photo #3.9

HIDEWOOD SOUTH PRIORITY 3 – WOMEN'S



Photo #3.10



Photo # 3.20



Photo #3.23



Photo # 3.29

HIDEWOOD SOUTH PRIORITY 3 – WOMEN'S



Photo # 3.30



Photo # 3.41



Photo # 3.42



Photo #3.44

HIDEWOOD SOUTH PRIORITY 3 – WOMEN'S

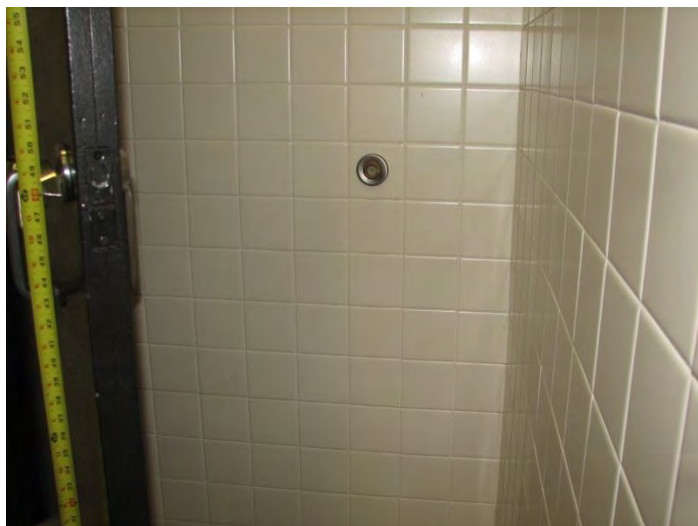


Photo # 3.46

HIDEWOOD SOUTH PRIORITY 4



Photo #4.6



Photo #4.7



Photo #4.8



Photo #4.12



The Interstate Rest Areas Study: Along the I-29 and I-90 Corridors

APPENDIX C AUDITMATE SUMMARY

Detailed Component List for One Facility
HIDE_RAS Hidewood Interstate Rest Area South Bound

9/25/2013

Class	Component	Comment	Quantity	Unit Cost	Lifespan	Age	Installed	Renewal Cost (RC)	Deferred Cost (DC)
Site Structures									
	Brick and Cedar Roof Picnic Shelters	Replace Shingles, repair & repaint roofs, clean and inspect masonry	4						
	Reinforced Concrete Picnic Tables		8						
	Information Display (outdoor)	needs cleaning	1						
Exterior Closure									
	Masonry Wall Mortar, Concrete Mortar	Needs tuckpointing							
	Masonry Wall Mortar, Concrete Mortar								
	Steel Double Door								
	Storefront Single door, Metal and Glass								
	Aluminum Frame and Glazing								
	Aluminum Frame and Glazing								
	Paint (trim, soffits)	Soffits need cleaning/paint							
Roofing and Drainage									
	Galvanized Metal Roof, Standing Seam, Factory Finish (entry)	Appears in good condition							
	Wood Shingle Roof	Ready for replacement							
	Wood Shingle Roof	Ready for replacement							
	Downspouts, Galvanized Steel, Factory Finish	fix at grade (grass covers drain ends).							
	Gutters, Galvanized Steel, Hung, Factory Finish								
Interior Construction									
	Ceramic Tile Wall	good condition in general							
	Painting, Interior, Average Grade	Fair condition, faded							
	Ceramic Tile Floor (restrooms 1/2 x 1/2)	Good condition, needs heavy cleaning and minor repairs							
	Quarry Tile Floor 6" x 6" (Lobby)	fair condition, needs heavy cleaning and minor repairs							
	Toilet Stall Door, Metal, Baked Enamel Finish	worn							
	Brick Interior Walls	general cleaning							
	Exposed Wood framing, ceiling	may have leak damage							
Plumbing									
	Tank, Holding Tank, 05000-6000 gallons	There are no reported issues. Suggest periodically testing for bacterial growth in the tanks							
	Water Softening System-Residential	There are no reported issues. Assuring that the water softener is regenerated properly will help to extend the life of the resin. Resin can gel if not periodically and continuously regenerated.				40			

Detailed Component List for One Facility
HIDE_RAS Hidewood Interstate Rest Area South Bound

9/25/2013

Class	Component	Comment	Quantity	Unit Cost	Lifespan	Age	Installed	Renewal Cost (RC)	Deferred Cost (DC)
	Domestic Water Well Pressure Tank, Medium	Tanks appear to be in good condition			40				
	Domestic Water Pressure Pump	Fully operational. Only preventive maintenance or minor repairs are required.	1 each		40	21	1992		
	Electric Water Cooler, High-Low Two Level Type	Fully operational. Only preventive maintenance or minor repairs are required.	1 each		40				
	Water Heater, Residential, Gas, 51-99 50 Gallons	Appears to be in good condition. Occasionally blowing the bottom out to remove residue and scale may add another 2 years to its life.			10				
	Faucet								
	Lavatory Sink, Set in Countertop Men's Toilet	Fully operational. Packaged, solid surface countertop with integral (3) lavatory bowls. Built-in push button tempered water supply.	1 each		40	21	1992		
	Lavatory Sink, Set in Countertop Women's Toilet	Fully operational. Packaged, solid surface countertop with integral (3) lavatory bowls. Built-in push button tempered water supply.	1 each		40	21	1992		
	Slop Sink, Single Bowl, Enamel	Fully operational. Wall mounted cast iron. Only preventative maintenance or minor repairs are required.			40	21	1992		
	Urinal, Porcelain, Wall-Hung	Appear to be in good condition for their age. Replacing units with low water consumption units will extend the life of			40	21	1992		
	Water Closet, Porcelain, Wall-Hung	Replacing units with low water consumption units will extend the life of the lagoon.			40	21	1992		
	Wall Hydrant	Fully operational. Wall mounted with loose key handle. Only preventive maintenance or minor repairs are required.	1 each		40	21	1992		
	Waste and Vent Piping, above floor	Appears to be in good condition, no apparent leaks. Vent piping is a combination of copper and PVC plastic pipe.			40	21	1992		
	Waste piping - under floor	Fully operational. Waste piping is a combination of cast iron pipe installed in 1980 and PVC plastic pipe installed in 1992			40	33	1980		
	Water Piping	Appears to be in good condition. Copper pipe and fittings			40	21	1992		
	Piping Insulation	Appears to be in good condition. Fabric jacketed pipe insulation.			40	21	1992		
	Valves	Valves appear to be in good condition			40	21	1992		

Detailed Component List for One Facility
HIDE_RAS Hidewood Interstate Rest Area South Bound

9/25/2013

Class	Component	Comment	Quantity	Unit Cost	Lifespan	Age	Installed	Renewal Cost (RC)	Deferred Cost (DC)
	Pipe Hangers and Supports	Appears to be in good condition.			40	21	1992		
Mechanical									
	AC Split System Outdoor Condensing, 03-3.5 Ton	Like new with no defects. Only preventive maintenance is required.							
	Furnace - High Efficiency, Propane gas fired	Fully operational. However, unit is beyond its expected service life	2 each		20	21	1992		
	Air Handling Unit, split System AC/Gas heat, 03-3.5 Ton		2 each	\$2,200.00	40	21	1992	\$4,400	\$0
	In-Line Exhaust fan	Units is in good condition. Only preventive maintenance and minor repairs are required.	1 each		25				
	Electric Duct Heater, 027,200 BTU/hr, 08KW 40,000 BTUH, 12.0 KW	Fully operational. However, unit is beyond its expected service life.							
	Space Heater, Gas-Fired, Ceiling-Mounted, 0-100 MBH 24,900 BTUH	Fully operational. However, unit is beyond its expected service life.			20				
	Hydronic Circulating Pump, Base-Mounted, 005 HP								
	Registers and Grilles	Fully operational			40	21	1992		
	Ductwork	Duct appears to be in good condition. No leaks			40	21	1992		
	Ductwork - underfloor	Duct appears to be in good condition.			40	21	1992		
	Duct Insulation	Rigid external duct insulation is in good condition			40	21	1992		
	Temperature Controls	Thermostats for all heating and cooling equipment are in operational condition	4 each		20	21	1992		
Electrical									
	Panelboard, Main Breaker, 3 PH, 208V, 0225-0250A	Fully operational, only preventive maintenance required.				21	1992		
	Panelboard, MLO, 3 PH, 208V, 0225-0250A	Fully operational, only preventive maintenance required.				33	1980		
	Fluorescent Fixture, 1' x 4' T-8	Fully operational, lamps are hard to get and expensive				21	1992		
	Fluorescent Fixture, 1' x 4' , Economy	Fully operational, lamps are hard to get and expensive				21	1992		
	Incandescent Fixture, Surface Mounted, Stock	Fully operational, only preventive maintenance required.				21	1992		
	Outdoor fixture, Cobrahead	Fully operational, only preventive maintenance required.	8 each						
	Outdoor fixture, HID, Large, Pole-Mounted	Internal wiring in the fixture is deteriorated.							
	Outdoor Fixture, Surface-Mounted, HID, Stock	Fully operational, some lenses show deterioration.							
	Outdoor Fixture, Surface-Mounted, HID, Stock, Small	Fully operational, some lenses show deterioration.				21	1992		

Detailed Component List for One Facility
HIDE_RAS Hidewood Interstate Rest Area South Bound

9/25/2013

Class	Component	Comment	Quantity	Unit Cost	Lifespan	Age	Installed	Renewal Cost (RC)	Deferred Cost (DC)
	CCTV Camera w/Cabling	Fully operational, only preventive maintenance required.							
	Electric Hand Dryer	Fully operational, only preventive maintenance required.				21	1992		
	Emergency Beacon - Well Monitoring System	Understand in good condition		\$2,800.00		21	1992		
	Phone Unit	Wall Mount, replace - Non ADA compliant	1 each			21	1992		
Utilities									
	U/G Fuel, Steel tank, single Wall Tank								
	U/G Fuel, Steel tank, single Wall Tank								
Sanitary Sewer System									
	Lagoons	Both lagoons were relined in 2011 and should not need additional repair in the near future.					2011		
	Sewage Piping System	No problems have been reported concerning the sewer pipes and manholes.							
Water System (Rural Water)									
	Water Pipe System	System is rural water with meter and UG storage tanks. Tanks were replaced with fiberglass tanks a few years ago, so should not need replacing in the near future. No problems reported concerning the water system.							
Infrastructure									
	Parking Area, Asphalt - 6"								
	Parking Area, Non Reinforced Concrete 9.5"	Most of the concrete pavement is in good shape. There is some curb and gutter (approximately 5%) that should be removed and replaced in the next 5-10 years. There is also a significant amount of corner cracking of concrete panels. Most of these can be repaired and sealed. Approximately 10% of the panels need to be removed and replaced in the next 10 years.							

Detailed Component List for One Facility
HIDE_RAS Hidewood Interstate Rest Area South Bound

9/25/2013

Class	Component	Comment	Quantity	Unit Cost	Lifespan	Age	Installed	Renewal Cost (RC)	Deferred Cost (DC)
	Sidewalk, Concrete	Concrete walks generally in good shape. Approximately 15% should be replaced in the next 5-10 years. Mudjacking has been done around the building. If this holds the walks around the building in place, these walks should last in excess of 10 years.							
	Landscaping	Landscaping consists of grass and trees, and is in good shape. Irrigation works well with yearly maintenance.							
	Wayfinding Signage	Signage is in good shape.							
	Site Lighting - Parking	Lights replaced in the mid-1990's. Some problems with the 50" light bases (a washer problem) needs to be addressed.							
	Site Lighting - Pedestrian	Lights replaced in the mid-1990's. No problems indicated.							

**TILFORD EASTBOUND
REST AREA**

TECHNICAL REVIEW REPORT

Prepared for:

Mr. Brad Remmich
South Dakota Department of Transportation
Office of Project Development
700 East Broadway Avenue
Pierre, SD 57501-2586
(605) 773-3093

Prepared by:

TSP
600 Kansas City Street
Rapid City, SD 57701-2712
(605) 343-6102

Felsburg Holt & Ullevig
6300 South Syracuse Way, Suite 600
Centennial, CO 80111
(303) 721-1440

FHU Reference No. 113039-01
December 2013



TABLE OF CONTENTS

	<u>Page</u>
I. INTRODUCTION -----	1
II. GENERAL OVERVIEW -----	2
A. Rest Area Layout -----	2
B. Field Visit Observations -----	4
C. User Environment -----	4
D. Existing Building Code Conformity -----	5
E. Americans with Disabilities Act (ADA) Survey -----	5
F. Energy and Water Usage Review -----	6
III. BUILDING SYSTEM OVERVIEW -----	7
A. Architectural System -----	7
B. Plumbing System -----	7
C. Mechanical System -----	8
D. Electrical System -----	8
E. Sanitary Sewer System -----	8
F. Water System -----	9
G. Infrastructure -----	9
IV. SUMMARY -----	10

APPENDIX A MAINTENANCE STAFF MEETING MINUTES

APPENDIX B ADA SURVEY RESULTS

APPENDIX C AUDITMATE SUMMARY

LIST OF FIGURES

	<u>Page</u>
Figure 1. Tilford Eastbound Rest Area Site Layout -----	3



I. INTRODUCTION

The Tilford Eastbound Rest Area is located along Interstate 90, approximately 16 miles north and west of the Rapid City, South Dakota metropolitan area. The rest area has direct access from Interstate 90 and provides one centralized parking lot for both passenger vehicles and trucks visiting the site.

The purpose of this report is to summarize the condition of existing site components and building systems for the facility as a whole. The intent for this report is to define the general status of the existing facilities given their age and use.

The report has been divided into two general areas of focus. The first section includes a general overview of the facility design and operations. Architectural issues, including the general capacity of the facilities and current operations, are reviewed and compared to current facility standards (i.e., building codes, ADA, etc.).

The systems overview section covers the type and condition of the components that make up the facility, and includes a summary evaluation of the site and building infrastructure. The site infrastructure repairs/replacement review includes sidewalks, lighting, signage, landscaping, and picnic shelters. The building systems infrastructure review includes items such as the building shell and structure, mechanical and plumbing systems, electrical, interior finishes, and communications/IT equipment.



II. GENERAL OVERVIEW

A. Rest Area Layout

The site is narrow and long paralleling Interstate 90 which runs north to south at this location. The main building is located to the south and west of the parking lot. North of the building is the picnic area. The parking lot parallels the rest area on the east, and sits at approximately 10'-15' below the entrance for the main facility. There is a separate parking lot to the south of the building that provides two accessible parking spaces.

Outdoor facilities include:

- Four precast 25'x25' teepee picnic shelters supporting one table each
- One 30'x30' main covered structure supporting four tables
- Three integral reinforced concrete tables/bench sets on concrete slabs are placed throughout the site
- Dumping station
- Portable utility shed approx. 10'x12' for tourism storage
- Portable utility shed approx. 10'x20' for equipment.
- Exterior visitor display structure
- Exterior uncovered vending machines and advertising equipment
- Built in benches at building
- Flag pole

Utilities Include:

- Well and water system that also serves the Tilford Westbound Rest Area.
- Gravity sewer system with lagoons are located on the Tilford Westbound Rest Area
- Lift station at south lagoon
- Power is three phase 208 volt, 0200-0250 amp
- 500 gallon propane gas tank

The 1,641 square foot facility includes the following:

- New wind screen installation at north entrance
- Lobby, and secured visitor center
- Men's and women's restrooms
- Mechanical, maintenance and storage area

Figure 1 shows the layout of the Tilford Eastbound Rest Area facility including the rest area's location in relation to major roadways in the area.



Figure 1. Tilford Eastbound Rest Area Site Layout



B. Field Visit Observations

A field meeting was held with TSP and SDDOT officials on September 19, 2013 to gain initial insights from the SDDOT maintenance team about the operation, history, and condition of the existing on-site facilities at the Tilford Eastbound Rest Area. A copy of the meeting minutes are contained in **Appendix A** of this report, and the following summarizes the key points of the meeting:

- The facility was designed and constructed in 1973 and since this time it has only been only partially upgraded to meet current industry standards (ADA requirements, building codes).
- The facility appears to have been designed for seasonal use, has not been winterized / insulated and has limited mechanical systems.
- Pedestrian access from the main building to the parking lot is difficult. The main building is located at the south end of the parking lot with the entrance approximately 10-15 feet higher than the parking lot.
- The existing ADA parking area is separated from the main lot on the south side of the main building.
- The Information lobby area is small, with minimal circulation area and clearances. This area has limited opportunities for increased use or expansion.
- Storage space for the tourist information center appears insufficient and not accessible per ADA.
- Each restroom provides four stalls and three sinks, with little space for circulation.

C. User Environment

Architecturally, the facility is an inviting modern rustic facility with an interesting form, and thoughtful use of natural materials (including stone, wood and tile). The design seems to appropriately reflect the culture of the Black Hills.

Recent roof changes has eliminated daylight to the lobby space from the back of the building which should also be noted and reviewed.

The four exterior 25' x '25' precast picnic shelters, were crudely constructed.



D. Existing Building Code Conformity

The current facilities were designed and constructed in 1973 to the codes at the time which lacked consideration for people with disabilities. To quantify the differences in code standards, the existing main building was evaluated per the ICC 2012 International Building Code which has been adopted by the State of South Dakota. Based on the use of the existing facility, the following building classifications were utilized in the comparison:

- Size: 1,641 square feet
- Occupant Type: Mercantile
- Construction Type: Type 3-b (or 5-b)
- Occupant Load: < 50
- Maximum access travel: 75 feet
- Required Exits: 1

The following outline the major areas where the existing building deviates from the requirements of the current Building Code (IBC 2012):

- GFI power outlets are not present in restrooms, and the information desk requires additional power connections
- Ventilation system not set for full time operation
- Facility does not include a family / assisted-use restroom
- Several areas are not ADA compliant per ICC A117.1-2009 (outlined in following sections)
- Storage placed around some electrical panels does not meet 36" minimum clearance

It should be noted that per the "Existing" Building Code, unless there are significant safety hazards, the facilities are not required to be modernized as a whole to meet current code standards. However, any repairs or new additions will need to be completed to these standards. The exception concerns ADA requirements, which are a retroactive federal requirement. When the ADA is addressed the project will need to also be completed per building code, which includes accessibility criteria (ICC- A117.1-2009).

E. Americans with Disabilities Act (ADA) Survey

As stated previously, the building was originally constructed prior to the full implementation of ADA standards. At some time it was partially updated to ADA standards in restrooms (per 1991 Federal Standards). To quantify the current facility compliance with ADA standards, a detailed survey was completed utilizing the "ADA Checklist for Readily Achievable Barrier Removal" per the DOJ ADA Standards for Accessible Design - 2010. The survey identified the following general deficiencies, and more detailed information is referenced in **Appendix B** of this report:

Priority 1 Deficiencies (access to building):

- Accessible parking spaces to rear of the building do not meet maximum slope limitations
- Parking signs do not meet current MUTCD standards
- ADA pull handle on entrance door has insufficient clearance, and an appropriate threshold to cover existing tile edge not provided



The Interstate Rest Areas Study: Along the I-29 and I-90 Corridors

- Way-finding signage to find existing accessible lot does not meet current standards

Priority 2 Deficiencies (Access to Goods and Services):

- Doorways from the lobby to each of the restrooms do not have sufficient corridor width. There is insufficient ADA clearance with the existing 36" wide corridor when using operable restroom entrance doors (46-52" min. required depending upon configuration)
- Information Area:
 - Area behind counter and information desks / map count height do not meet ADA clearance or height standards
 - 24" access door to back storage/maintenance area not wide enough (36" minimum). - Storage areas should be accessible as well as some shelving, for those managing the information areas
 - Signage does not meet current ADA standards
- Only one of twelve exterior picnic benches has been modified to current ADA standards

Priority 3 (Restrooms):

- Stall doors not self-closing
- Men's toilet does not provide 18" clearance from partition
- Toilet paper holders in men's and women's stalls do not meet standards
- Entrance doors do not meet closure pressure or ADA pull handle standards

Priority 4 (additional access) Deficiencies:

- Phone is free standing and does not include provisions for sound control, TTY plug in, and shelf.

F. Energy and Water Usage Review

Propane use for 2011 was 857 gallons, equating to 48.7 thousand British thermal units / square feet / year (MBTU/SF/YR). This use data indicates the site uses a reasonable amount of energy for this type of building. Of note, heavy propane use typically exceeds 100 MBTU/SF/YR.

Electrical use for 2012 was 38,655 kilowatts per hour (KWH), equating to 24.2 KWH/SF/YR or 82.5 MBTU/SF/YR. The data suggests a relatively high amount of energy usage for this type of building when compared to industry standards (50 MBTU/SF/YR or 15 KWH/SF/YR). The majority of the electrical use is dedicated to site lighting, well pumps, and sewage pumps, which are normally not included when calculating high energy usage.

Water use averages 850 gallons per day during off-season, and 2200 gallons per day during the tourist season of May through August.



III. BUILDING SYSTEM OVERVIEW

The following sections include a general review of individual building and site components, starting with site components and then broken down by individual disciplines (Architectural Systems, Mechanical, Electrical, Plumbing, and Civil/Site systems). The discussion generally parallels SDDOT AuditMate database format.

A detailed summary of each discipline section in the current AuditMate format including general comments of individual line items are contained in **Appendix C** of this report. The AuditMate contains both existing line items and recommended updates to the SDDOT database, which are shown in **bold** font.

A. Architectural System

The original 1966 structure appears to have been a vaulted toilet building including the picnic shelters and benches. The vault building consists of un-insulated reinforced concrete block walls (CMU) and un-insulated precast roof planks. The building was converted to a utility room with the addition of the larger and current facility in 1972. In supplied drawings, a smaller basement vault space of 11' x 16' x 5' high is shown, and was not inspected for this report.

The shell and interior walls are constructed either as stone or as concrete block bearing walls. The roof system above the lobby consists of exposed wood beams and wood plank decking, with conventional wood framing above the restrooms. The back vault area roof structure is constructed of precast planks.

Around 2000, a new metal roof structure was installed over the old wood roof. The existing roofing system appears to have been originally a built-up system. The metal replacement roof was installed at a new slope over the entire facility, including the vault building, and have assumed that insulation and proper venting were included. Internal drains were shut off and a new exterior gutter and drain system was installed.

The year round facility appears to have been originally designed for seasonal summer use. Per the original drawings, the exterior stone bearing walls and restrooms have limited insulation, but the concrete block walls, the roof over the lobby, all windows and the service door remain un-insulated. It was assumed that the new roof installed in 2000 has been insulated.

B. Plumbing System

Wall hung water closets and urinals, and countertop lavatory sinks are vitreous china installed in 1973. Lavatories faucets and water closets flush valves are electronic type, battery operated. There is also a wall hung vitreous china drinking fountain that was installed in 1973.

Waste and vent piping is cast iron, was installed in 1973 as well as copper water piping and some insulation. Much of the water piping insulation is damaged or missing. There is a water bottle filler surface mounted on the outside of the building piped in cross-linked polyethylene (PEX).



Water is supplied from a shallow well and pumped to a 5,000 gallon underground fiberglass holding tank installed in 2001. A well pressure tank was also installed in 2001.

All water is softened with a dual water softener, installed in 2000 and chlorinated with an injector. If left un-softened, hard well water would require maintenance on the system every three years. An electric water heater was installed in 2005. A small water circulator pump, installed in 2002, circulates domestic hot water from the fixtures back to the water heater.

C. Mechanical System

Building is heated and cooled with a ducted system and central air conditioning. The furnace is propane gas fired, installed in 1973, and supplied from a 500 gallon above ground propane tank. The outdoor condensing unit is a Lennox five ton cooling unit (installed 1993) that shows hail damage. Thermostat for the cooling unit is located in the information center.

Exhaust ventilation for the toilet rooms is ducted by a single small utility fan set. The fan is controlled by a timer and runs 15 minutes every hour. Exhaust grilles are wall mounted on the water closet wall in each toilet room. Air is exhausted through a wall louver in the mechanical room, and there is no mechanical outside air.

A small electric unit heater provides heat for the mechanical room, and was installed in 1993.

D. Electrical System

The building is served by a three phase 208 volt, 250 amp service. There are two 225 amp panels located the mechanical room. Panels are clearly labeled as to what each breaker serves, and all wiring is run in conduit. Panel boards appeared to be in adequate condition, with no signs of excessive rust or deterioration.

All indoor lighting fixtures are original, and installed in 1973. All lamps contain fluorescent bulbs, and the remaining lighting fixtures in the building are a mix of recessed cans and wall mounted scones in the main lobby, and ceiling recessed mounted fixtures in the restroom. Restroom light fixtures are starting to pull away from the ceiling and may become a source of vandalism.

Outdoor lighting is primarily high pressure sodium or HID. Wall packs are used on the building, and some show signs of moisture inside the lens, indicating the lens is no longer sealing properly. Most outdoor lighting was installed between 1989 and 1997.

Hand dryers are electric and operating properly.

CCTV is installed in the lobby. There is also an emergency beacon system, the operation of which was not immediately observable, but confirmed by staff.

E. Sanitary Sewer System

The sanitary sewer system consists of gravity flow sewer lines to a lagoon located east of the Interstate 90 corridor on the north side of the Tilford Westbound Rest Area. Two additional lagoons are located south of the Tilford Westbound Rest Area, primarily serving the westbound



rest area. All three of the lagoons appear to be the same size (approximately 250'x110'). A lift station is used to alternately pump sewage between the north and south lagoons, allowing waste water flow from both the eastbound and westbound rest areas to be diverted to any of the three lagoons.

According to maintenance personnel, the ponds provide adequate capacity and the lift station is working well. A meter has been suggested by the South Dakota Department of Environment and Natural Resources (DENR) for more accurate determination of flow to each pond. The age and material of the pipe is unknown, but no problems have been detected with the system at this time. The dump station also flows to the lagoon on the north side of the Tilford Westbound Rest Area.

A natural problem does occur with the open ponds on either side of the westbound rest area. Depending upon the direction of the winds, the smell of effluent will be present on site and at the outdoor picnic areas. There are times when these smells are extreme as the chemical treatment coming from the dump stations/campers counteracts the treatment at the ponds.

F. Water System

The water source for this site is a well and fiberglass storage tank, which also serves the Tilford Westbound Rest Area through pipes underneath the Interstate 90 corridor. No problems were indicated by the maintenance staff with this system.

G. Infrastructure

The parking area is concrete with some asphalt shoulders along the ramps and asphalt in the handicapped parking area behind the building. The general condition of the concrete on the ramp and in the parking area is good, with most of the deterioration being in the joints. The pavement condition is confirmed by the latest ratings done by the SDDOT. In these ratings, joint seals are the lowest rated followed by joint spalling. Joint repair and sealing should be done soon to extend the life of the pavement another 15 years to a life span of 60 years.

Asphalt pavement is used for shoulders along the ramps and paving in the handicapped parking area. The asphalt in the handicapped parking area has some cracking but is in good condition. Sealing the cracks (est. 25% of area) and applying a seal coat (100% of surface) would help extend the life of the asphalt. The asphalt along the ramps has some grass growing in cracks which can lead to additional deficiencies.

Concrete walk extends along the parking spaces, around the building and to picnic shelters located around the site. The majority of the concrete sidewalk is in good condition. Approximately 10% of the sidewalk has cracks that may require replacement in the future. Most of this cracked walk is primarily on the northeast side of the building around the information kiosk.



IV. SUMMARY

The Tilford Eastbound Rest Area is located along Interstate 90, approximately 16 miles north and west of the Rapid City, South Dakota metropolitan area. The rest area has direct access from Interstate 90 and provides one centralized parking lot for both passenger vehicles and trucks visiting the site.

The purpose of this report was to summarize the condition of existing site components and building systems for the facility as a whole, and to define the general status of the existing facilities given their age and use.

As the main building structure was constructed in 1973, the general building systems as a whole are nearing the end of their design life. There will be an increasing need ahead for repairs and reconstruction including system upgrades to the mechanical, power and lighting systems.

The facility will need to be modified to comply with ADA/building code requirements. The extent of which has yet to be determined, as an additional factor will be in identifying the added space required to modify the restroom entrances, to support increased user loads (if any), and to provide family assist restroom(s).



The Interstate Rest Areas Study: Along the I-29 and I-90 Corridors

APPENDIX A MAINTENANCE STAFF MEETING MINUTES



October 15, 2013

MEETING MINUTES

SDDOT INTERSTATE REST AREA STUDY

FHU Reference No. 113039-01

Tilford Eastbound Maintenance Review Meeting

Tilford Eastbound Rest Area

Date of Meeting: September 19, 2013

In attendance:

- Brad Remmich – SDDOT
- Dan Cooper – SDDOT
- Tim Roach – TSP
- Steve Tebben – TSP
- Todd Schultz - TSP

The purpose of the meeting was to gain initial insights from the SDDOT maintenance team about the operation, history, and condition of the existing on-site facilities at the Tilford Eastbound rest area. The following summarizes the key points of the meeting:

FACILITY USE

- There is consistent year round use of the facilities by truckers and local commuters with no substantial slow periods. In the summer months, there is a notable increase in tourists (many in campers) which peaks during the Sturgis Rally. There are times during this Rally week that the facility is overflowing with insufficient parking, restrooms stalls, and lobby space.
- Based on SDDOT information, with the exception of the Sturgis Rally, the facility seems to be sized appropriately for all user groups, and has sufficient stalls for auto, camper, and truck parking. There is only a limited need for the picnic shelters – only about ½ of the units are used most of the times.
- The facility houses a full time manned tourist center during the summer months (roughly from May to August). This center was not staffed or open at the time of the meeting; however we understand that there is insufficient space for the displays, and for short and long-term storage. Currently long-term storage of travel documents are placed in the maintenance rooms, and in an outside portable shed (approx. 12'x 12').
- The facility gets a higher percentage of male users for the restrooms (perhaps truckers).

USER INFORMATION

- Truckers use this site heavily as the closest next stop to the west is about 130 miles towards Gillette. Many will stop overnight at the site. Many commuters also use the facility year round traveling between Spearfish and Rapid City.

October 15, 2013

Tilford Eastbound Maintenance Review Meeting

Page 2

- There is a higher proportion of tourists with campers at this location – it's should be noted that the dump station is highly utilized by this group and appears to be a worthwhile service. Also, Dan Cooper (SDDOT) has developed a lid system for the tank which limits the ability of the user to dump undesirable items and garbage which clogs up the system.

FACILITY NEEDS / ISSUES

- There is no history of formal complaints from users at this location.
- The facility is located at the eastern end of the general parking lot (rather than centrally located). The structure and picnic areas are uniquely located prominently approximately 10-15' above the main parking lot area. Currently there is no ADA accessible pedestrian access from the main lot to the structure. ADA parking is provided in a separate small hard to find lot at the side/rear of the facility with two parking spaces. This approach for ADA parking is not adequate for the long term due to the size and separation, and the inability to return to the main lot of this lot is full.
- As accessibility from the main lot is limited to steep sidewalks and stairs, for the long term, a serious study is recommended to review alternate options for access and circulation. Given the nature of the site, a rework the grading of the parking lot and auto/truck access routes is likely which may impact the long-term viability of the properties.
- The site is landlocked between the county road and the interstate, and greatly compromised by the grade challenges. In the long term future, it may not be suited for much expansion in parking or for a new facility with the space limitations. Should a major expansion in parking be needed this would require building into the picnic area and extensive retaining walls at a minimum.
- The tourism information screen in the lobby is ineffectively slow as it works on standard phone modem connection. The facility needs internet access for this device to be effective.
- There are no immediate safety issues reported. A video monitor system is very successful in reducing vandalism and security problems.
- There is no history of accidents related to current facility and on site circulation.
- Site Systems (landscaping, lighting, trash, ponds, etc.):
 - Sidewalk, stairs, and paving show signs of aging and wear.
 - The parking lot has been reworked with a new truck parking layout (parallel), which we understand works very effectively.
 - Lagoon System and Lift Station are well maintained and have no history of a major overhaul to date.
 - New fiberglass water tank has been installed (at Tilford East) about 10-12 years ago for the well water system, which supports both the East and West facilities.
 - Lawn Sprinkler system works well.
 - Site parking, pedestrian, and exterior building lighting systems were replaced "a few years ago".
- Building Systems (shell, interior finishes, MEP):
 - Restrooms were modified to ADA many years back - a stall in each was deleted to make space for the larger stalls.
 - Interior Lighting outdated and failing – maintenance cost and problems.

October 15, 2013

Tilford Eastbound Maintenance Review Meeting

Page 3

- General building power is three phase power system - equipment is old and may need modernization/replacement for parts.
- Mechanical systems are very outdated and will eventually need replacement. Bathroom ventilation is set to 15 minute exhaust venting/hr., probably to save energy, but is insufficient, as smell is noticeable.
- Propane fired furnace was replaced a few years ago (heat pump system).
- Security grill at tourist area is old and repair parts are hard to find.

SDDOT MAINTENANCE STAFF REQUESTS

- Facility is lacking in much needed storage and display space for the tourist information area.
- Information Space is undersized, with little room for visitors and displays -the available area is noticeably cramped. No storage space provided for in original design.
- Counters not ADA compliant and have insufficient clearances.
- Rear access door to maintenance rooms too narrow (not ADA).
- Sliding Gate needs replacement.

These meeting minutes were prepared by Tim Roach (TSP). Please contact me at roachtj@teamtsp.com or 605-343-6102 for corrections or clarifications.



The Interstate Rest Areas Study: Along the I-29 and I-90 Corridors

APPENDIX B ADA SURVEY RESULTS

SDDOT Rest Area Improvements
FHU Reference Number 13-039-01
TSP Project Number 03120855

Building **TILFORD EAST**

Location **90 E., MRM 41**

Date **09-19-2013 (Inspection)**

ADA Checklist for Readily Achievable Barrier Removal

Priority 1 – Approach & Entrance



SDDOT Rest Area Improvements

FHU Reference Number 13-039-01

TSP Project Number 03120855

Project

Building **TILFORD EAST**

Location **90 E., MRM 41**

Date **09-19-2013 (Inspection)**

Surveyors **Timothy Roach, AIA**
Todd Schultz, PE

Contact Information **TSP – (605) 343-6102**

An accessible route from site arrival points and an accessible entrance should be provided for everyone.



Institute for Human Centered Design
www.HumanCenteredDesign.org

November 2011

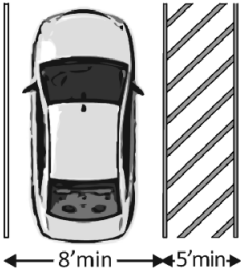


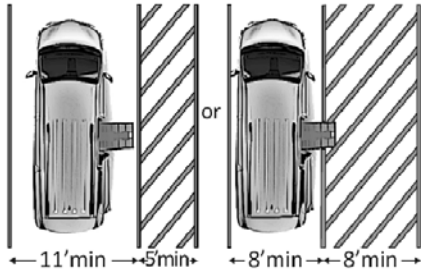
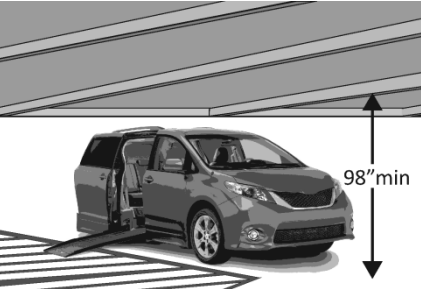
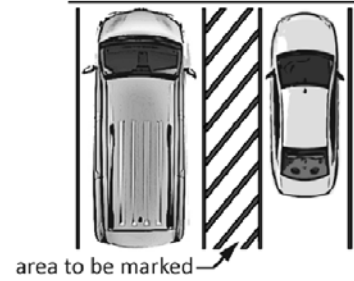
ADA National Network
Questions on the ADA 800-949-4232 voice/tty
www.ADAchecklist.org


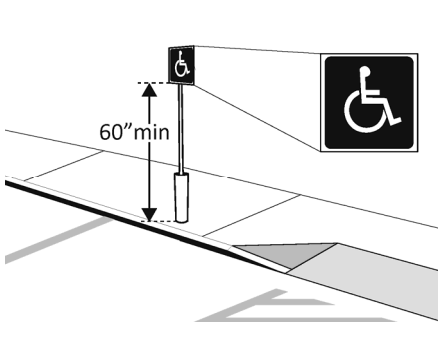
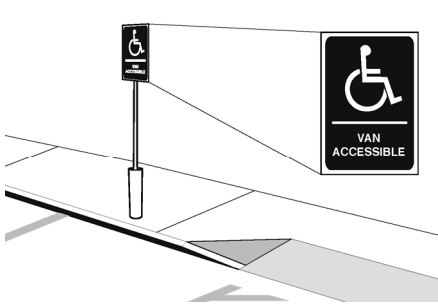

This checklist was produced by the New England ADA Center, a project of the Institute for Human Centered Design and a member of the ADA National Network. This checklist was developed under a grant from the Department of Education, NIDRR grant number H133A060092-09A. However the contents do not necessarily represent the policy of the Department of Education, and you should not assume endorsement by the Federal Government.

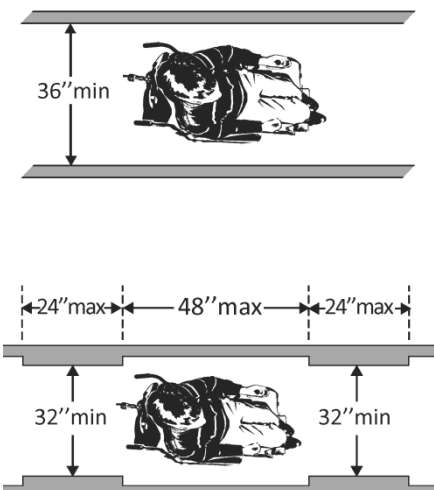
Questions or comments on the checklist contact the New England ADA Center at 617-695-0085 voice/tty or ADAinfo@NewEnglandADA.org

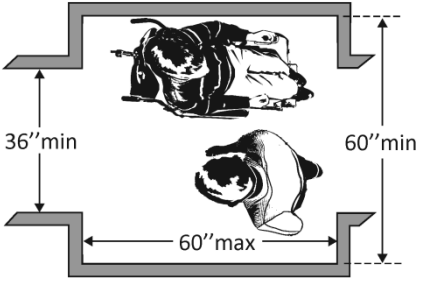
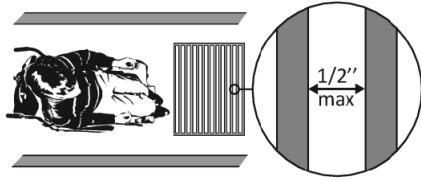
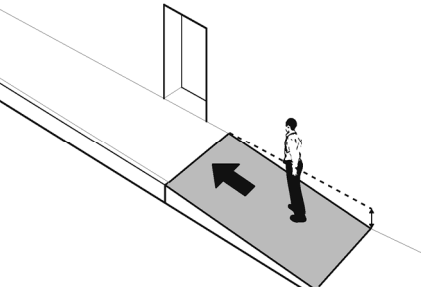
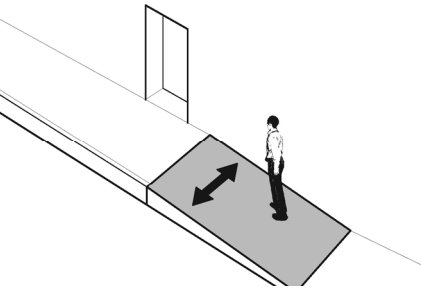
For the full set of checklists, including the checklists for recreation facilities visit www.ADAchecklist.org.

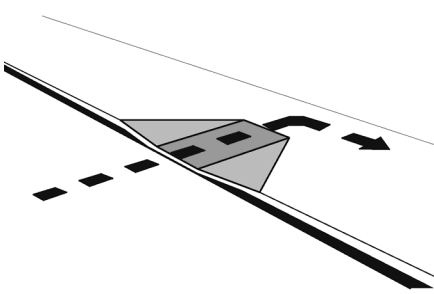
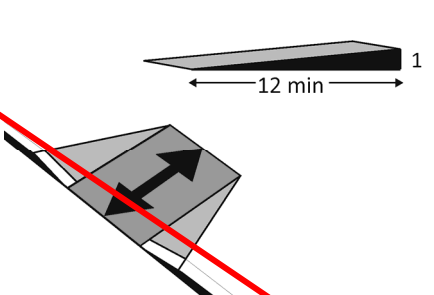
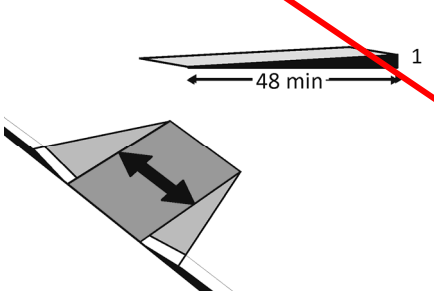
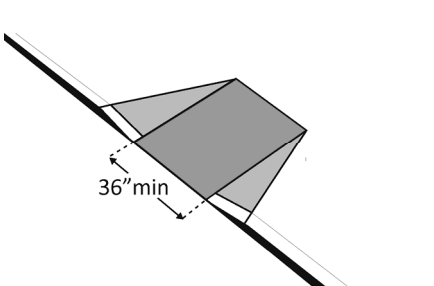
Priority 1 – Approach & Entrance		Comments	Possible Solutions												
<p>1.1 Is there at least one route from site arrival points (parking, passenger loading zones, public sidewalks and public transportation stops) that does not require the use of stairs?</p>	<p><input checked="" type="checkbox"/> Yes <input type="checkbox"/> No</p> <p>If yes, location of route:</p>	<ul style="list-style-type: none"> From left/rear side of building to front door Separate lot <p>Photo #: 1</p>	<ul style="list-style-type: none"> Add a ramp Regrade to 1:20 maximum slope Add a lift if site constraints prevent other solutions 												
<p>Parking (2010 Standards – 208 & 502) Note: Accessible parking spaces should be identified by size, access aisle and signage.</p>															
<p>1.2 If parking is provided for the public, are an adequate number of accessible spaces provided?</p>	<p><input checked="" type="checkbox"/> Yes <input type="checkbox"/> No</p> <p>Total #:</p> <p>Accessible #: 2</p>	<table border="1"> <thead> <tr> <th>Total Spaces</th> <th>Accessible Spaces</th> </tr> </thead> <tbody> <tr> <td>1 - 25</td> <td>1</td> </tr> <tr> <td>26 - 50</td> <td>2</td> </tr> <tr> <td>51 - 75</td> <td>3</td> </tr> <tr> <td>76 - 100</td> <td>4</td> </tr> <tr> <td colspan="2">100+ see 2010 Standards 208.2</td> </tr> </tbody> </table> <p>Photo #: 2</p>	Total Spaces	Accessible Spaces	1 - 25	1	26 - 50	2	51 - 75	3	76 - 100	4	100+ see 2010 Standards 208.2		<ul style="list-style-type: none"> Reconfigure by repainting lines
Total Spaces	Accessible Spaces														
1 - 25	1														
26 - 50	2														
51 - 75	3														
76 - 100	4														
100+ see 2010 Standards 208.2															
<p>1.3 Of the accessible spaces, is at least one a van accessible space?*</p>	<p><input checked="" type="checkbox"/> Yes <input type="checkbox"/> No</p>	<p>*For every 6 or fraction of 6 parking spaces required by the table above, at least 1 should be a van accessible space.</p> <p>Photo #: 2</p>	<p>* If constructed before 3/15/2012, parking is compliant if at least 1 in every 8 accessible spaces is van accessible</p> <ul style="list-style-type: none"> Reconfigure by repainting lines 												
<p>1.4 Are accessible spaces at least 8 feet wide with an access aisle at least 5 feet wide?</p>	<p><input checked="" type="checkbox"/> Yes <input type="checkbox"/> No</p> <p>Measurement:</p>	 <p>8' min 5' min</p> <p>Photo #: 2</p>	<ul style="list-style-type: none"> Reconfigure by repainting lines <p>Two spaces can share an access aisle (check state requirements; some states, such as Connecticut, require an access aisle for</p>												

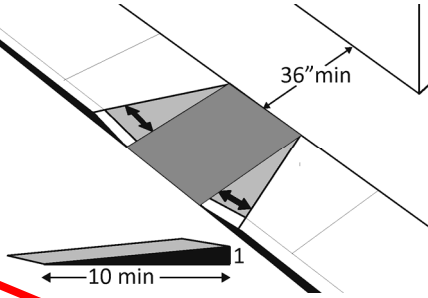
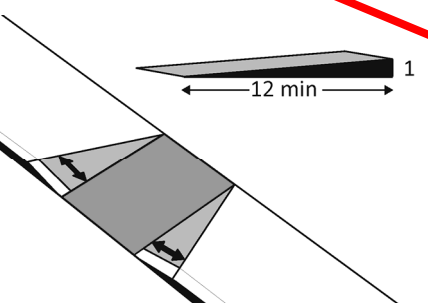
<p>1.5 Is the van accessible space: At least 11 feet wide with an access aisle at least 5 feet wide? Or At least 8 feet wide with an access aisle at least 8 feet wide?</p>	<p><input type="checkbox"/> Yes <input checked="" type="checkbox"/> No Measurement: <input checked="" type="checkbox"/> Yes <input type="checkbox"/> No Measurement:</p>		<p>8 ft wide with access aisle 8 ft. Photo #: 2</p>	<p>each space) • Reconfigure to provide van-accessible space(s) • •</p>
<p>1.6 Is at least 98 inches of vertical clearance provided for the van accessible space?</p>	<p><input type="checkbox"/> Yes <input type="checkbox"/> No Measurement:</p>		<p>NA Photo #:</p>	<p>• Reconfigure to provide van-accessible space(s) • •</p>
<p>1.7 Are the access aisles marked so as to discourage parking in them?</p>	<p><input checked="" type="checkbox"/> Yes <input type="checkbox"/> No</p>		<p>Photo #: 2</p>	<p>• Mark access aisles • • The marking method and color may be addressed by state/local requirements</p>
<p>1.8 Is the slope of the accessible parking spaces and access aisles no steeper than 1:48 in all directions?</p>	<p><input type="checkbox"/> Yes <input checked="" type="checkbox"/> No Measurement: 3% SLOPE</p>		<p>Photo #: 2</p>	<p>• Regrade surface • •</p>

<p>1.9 Do the access aisles adjoin an accessible route?</p>	<p><input checked="" type="checkbox"/> Yes <input type="checkbox"/> No</p>		<p>Photo #: 1</p>	<ul style="list-style-type: none"> • Create accessible route • Relocate accessible space •
<p>1.10 Are accessible spaces Identified with a sign that includes the International Symbol of Accessibility?</p> <p>Is the bottom of the sign at least 60 inches above the ground?</p>	<p><input type="checkbox"/> Yes <input checked="" type="checkbox"/> No</p> <p><input checked="" type="checkbox"/> Yes <input type="checkbox"/> No</p> <p>Measurement:</p>		<p>• Need signs for both spaces</p> <p>• One sign is between both spaces</p> <p>Photo #: 2</p>	<ul style="list-style-type: none"> • Install signs • • <p>The International Symbol of Accessibility is not required on the ground by the 2010 Standards</p>
<p>1.11 Are there signs reading “van accessible” at van accessible spaces?</p>	<p><input checked="" type="checkbox"/> Yes <input type="checkbox"/> No</p>		<p>Photo #: 2</p>	<ul style="list-style-type: none"> • Install signs • •
<p>1.12 Of the total parking spaces, are the accessible spaces located on the closest accessible route to the accessible entrance(s)?</p>	<p><input checked="" type="checkbox"/> Yes <input type="checkbox"/> No</p>		<p>• FROM REAR PARKING LOT</p> <p>Photo #: 1</p>	<ul style="list-style-type: none"> • Reconfigure spaces • • <p>If parking lot serves multiple entrances, accessible parking should be dispersed</p>

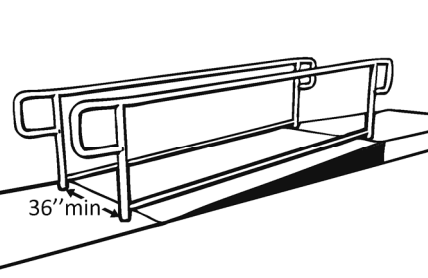
Exterior Accessible Route (2010 Standards – Ch.4)				
<p>1.13 Is the route stable, firm and slip-resistant?</p>	<p><input type="checkbox"/> Yes <input checked="" type="checkbox"/> No</p>		<ul style="list-style-type: none"> • DUE TO 3% SLOPE OF PAVEMENT • ROOF DRAINS ON SIDEWALK – POTENTIAL FOR ICE <p>Photo #: 1, 2</p>	<ul style="list-style-type: none"> • Repair uneven paving • Fill small bumps and breaks with patches • Replace gravel with asphalt or other surface
<p>1.14 Is the route at least 36 inches wide?</p> <p>Note: The accessible route can narrow to 32 inches min. for a max. of 24 inches. These narrower portions of the route must be at least 48 inches from each other.</p>	<p><input checked="" type="checkbox"/> Yes <input type="checkbox"/> No</p> <p>Measurement:</p>		<p>Photo #: 2</p>	<ul style="list-style-type: none"> • Change or move landscaping, furnishings or other items • Widen route •

<p>1.15 If the route is greater than 200 feet in length and no less than 60 inches wide, is there a passing space no less than 60 x 60 inches?</p>	<p><input type="checkbox"/> Yes <input checked="" type="checkbox"/> No</p> <p>Measurement:</p>		<p>Photo #: 2</p>	<ul style="list-style-type: none"> • Widen route for passing space • •
<p>1.16 If there are grates or openings on the route, are the openings no larger than 1/2 inches to the dominant direction of travel?</p> <p>Is the long dimension perpendicular to the dominant direction of travel?</p>	<p><input type="checkbox"/> Yes <input checked="" type="checkbox"/> No</p> <p>Measurement:</p> <p><input type="checkbox"/> Yes <input type="checkbox"/> No</p> <p>NA</p>		<p>Photo #:</p>	<ul style="list-style-type: none"> • Replace or move grate • •
<p>1.17 Is the running slope no steeper than 1:20, i.e. for every inch of height change there are at least 20 inches of route run?</p>	<p><input type="checkbox"/> Yes <input checked="" type="checkbox"/> No</p> <p>Measurement:</p>		<p>• SIDEWALK OK, PAVEMENT 3% SLOPE, WILL EXCEED 2% ALLOWANCE</p> <p>Photo #:</p>	<ul style="list-style-type: none"> • Regrade to 1:20 max. • If steeper than 1:20 and no steeper than 1:12, treat as a ramp and add other features such as edge protection and handrails •
<p>1.18 Is the cross slope no steeper than 1:48?</p>	<p><input type="checkbox"/> Yes <input checked="" type="checkbox"/> No</p> <p>Measurement:</p>		<p>Photo #:</p>	<ul style="list-style-type: none"> • Regrade to 1:48 max. • •

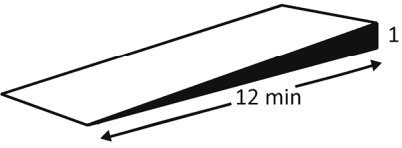
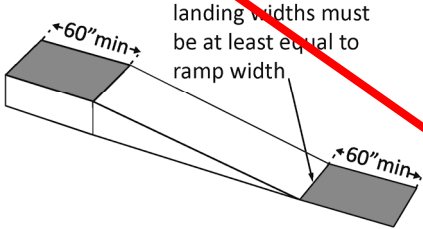
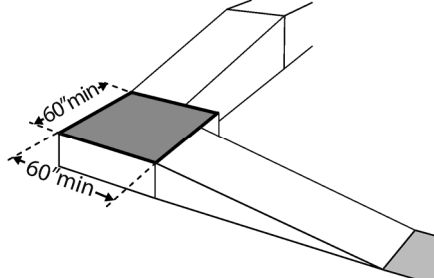
Curb Ramps (2010 Standards – 406)				
<p>1.19 If the accessible route crosses a curb, is there a curb ramp?</p>	<p><input type="checkbox"/> Yes <input type="checkbox"/> No</p>		<p>Photo #:</p>	<ul style="list-style-type: none"> • Install curb ramp • •
<p>1.20 Is the running slope of the curb ramp no steeper than 1:12, i.e. for every inch of height change there are at least 12 inches of curb ramp run?</p>	<p><input type="checkbox"/> Yes <input type="checkbox"/> No</p> <p>Measurement:</p>		<p>Photo #:</p>	<ul style="list-style-type: none"> • Regrade curb ramp • •
<p>1.21 Is the cross slope of the curb ramp, excluding flares, no steeper than 1:48?</p>	<p><input type="checkbox"/> Yes <input type="checkbox"/> No</p> <p>Measurement:</p>		<p>Photo #:</p>	<ul style="list-style-type: none"> • Regrade curb ramp • •
<p>1.22 Is the curb ramp, excluding flares, at least 36 inches wide?</p>	<p><input type="checkbox"/> Yes <input type="checkbox"/> No</p> <p>Measurement:</p>		<p>Photo #:</p>	<ul style="list-style-type: none"> • Widen curb ramp • •

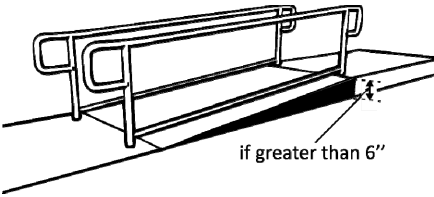
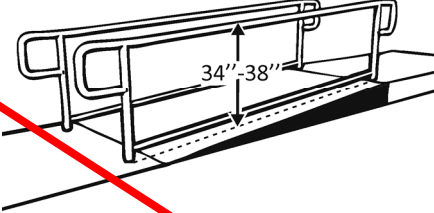
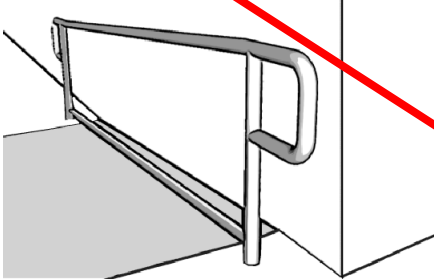
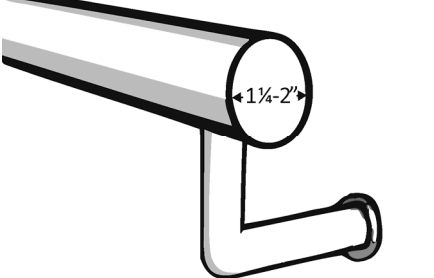
<p>1.23 At the top of the curb ramp is there a level landing (slope no steeper than 1:48 in all directions) that is at least 36 inches long and at least as wide as the curb ramp? If there are curb ramp flares, are the slopes of the flares no steeper than 1:10, i.e. for every inch of height change there are at least 10 inches of flare run?</p>	<p><input type="checkbox"/> Yes <input type="checkbox"/> No Measurement:</p> <p><input type="checkbox"/> Yes <input type="checkbox"/> No Measurement:</p>		<p>Photo #:</p>	<ul style="list-style-type: none"> • Reconfigure • Add ramp flares •
<p>1.24 If the landing at the top is less than 36 inches long, are there curb ramp flares? Are the slopes of the flares no greater than 1:12, i.e. for every inch of height change there are at least 12 inches of flare run?</p>	<p><input type="checkbox"/> Yes <input type="checkbox"/> No Measurement:</p> <p><input type="checkbox"/> Yes <input type="checkbox"/> No Measurement:</p>		<p>Photo #:</p>	<ul style="list-style-type: none"> • Add ramp flares • Regrade flares •

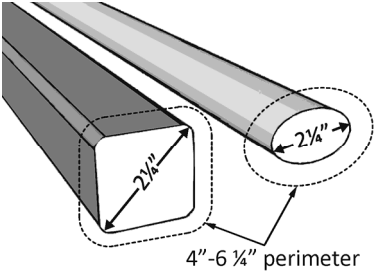
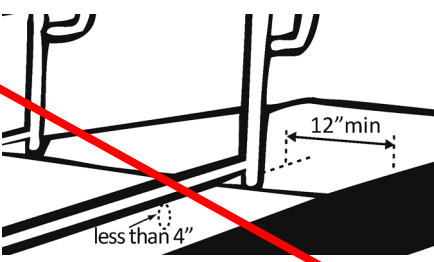
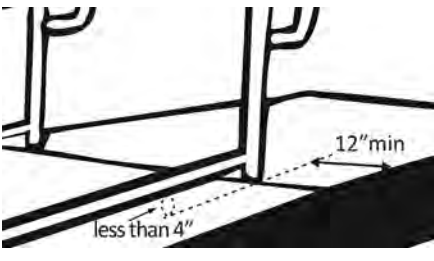
Ramps (2010 Standards – 405 & 505) **Note: If any portion of the accessible route is steeper than 1:20, it should be treated as a ramp.**




<p>1.25 If there is a ramp (other than curb ramps), is it at least 36 inches wide? If there are handrails, measure between the handrails.</p>	<p><input type="checkbox"/> Yes <input checked="" type="checkbox"/> No Measurement:</p>		<p>Photo #: 3</p>	<ul style="list-style-type: none"> • Alter ramp • •
--	---	---	--------------------------	--

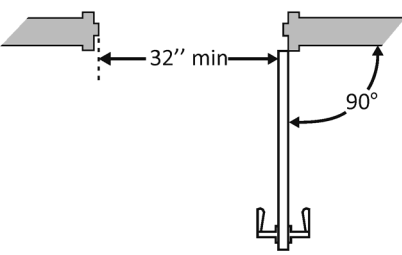
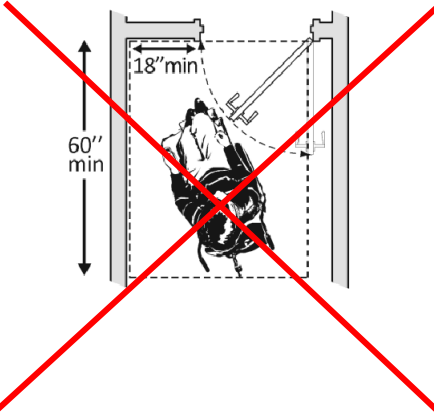
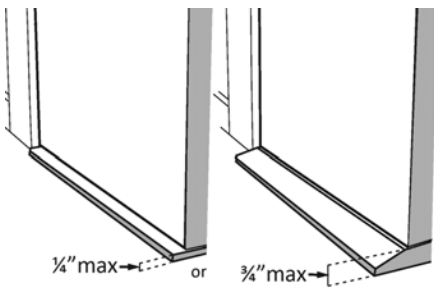
<p>1.26 Is the surface stable, firm and slip resistant?</p>	<p><input type="checkbox"/> Yes <input type="checkbox"/> No</p>		<p>Photo #:</p>	<ul style="list-style-type: none"> • Resurface ramp • •
--	---	--	-----------------	--

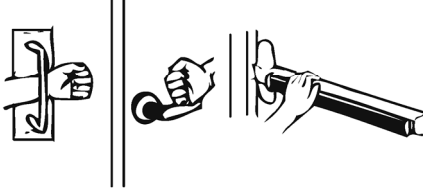
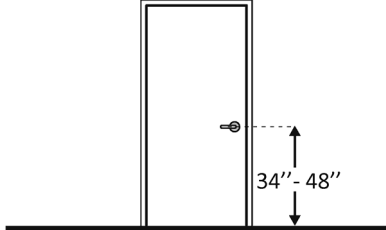
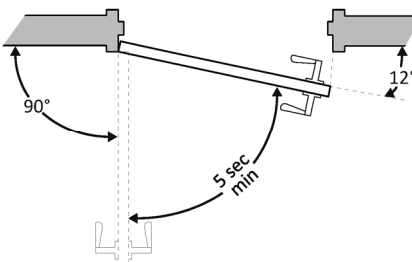
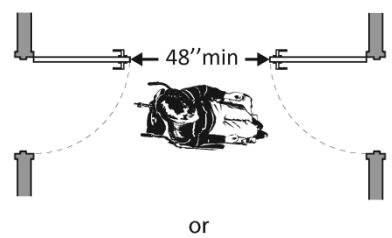
<p>1.27 For each section of the ramp, is the running slope no greater than 1:12, i.e. for every inch of height change there are at least 12 inches of ramp run?</p> <p>Note: Rises no greater than 3 inches with a slope no steeper than 1:8 and rises no greater than 6 inches with a slope no steeper than 1:10 are permitted when such slopes are necessary due to space limitations.</p>	<p><input type="checkbox"/> Yes <input type="checkbox"/> No</p> <p>Measurement:</p>		<p>Photo #:</p>	<ul style="list-style-type: none"> • Alter or relocate ramp • Lengthen ramp to decrease slope •
<p>1.28 Is there a level landing that is at least 60 inches long and at least as wide as the ramp:</p> <p>At the top of the ramp?</p> <p>At the bottom of the ramp?</p>	<p><input type="checkbox"/> Yes <input type="checkbox"/> No</p> <p>Measurement:</p> <p><input type="checkbox"/> Yes <input type="checkbox"/> No</p> <p>Measurement:</p>		<p>Photo #:</p>	<ul style="list-style-type: none"> • Alter ramp • •
<p>1.29 Is there a level landing where the ramp changes direction that is at least 60 x 60 inches?</p>	<p><input type="checkbox"/> Yes <input type="checkbox"/> No</p> <p>Measurement:</p>		<p>Photo #:</p>	<ul style="list-style-type: none"> • Alter ramp • •

<p>1.30 If the ramp has a rise higher than 6 inches, are there handrails on both sides?</p>	<p><input type="checkbox"/> Yes <input type="checkbox"/> No</p> <p>Measurement:</p>		<p>Photo #:</p>	<ul style="list-style-type: none"> • Add handrails • • <p>Curb ramps are not required to have handrails</p>
<p>1.31 Is the top of the handrail gripping surface no less than 34 inches and no greater than 38 inches above the ramp surface?</p>	<p><input type="checkbox"/> Yes <input type="checkbox"/> No</p> <p>Measurement:</p>		<p>Photo #:</p>	<ul style="list-style-type: none"> • Reconfigure or replace handrails • •
<p>1.32 Is the handrail gripping surface continuous and not obstructed along the top or sides?</p> <p>Is the bottom of the handrail gripping surface obstructed for no more than 20 percent of its length?</p>	<p><input type="checkbox"/> Yes <input type="checkbox"/> No</p> <p><input type="checkbox"/> Yes <input type="checkbox"/> No</p> <p>Measurement:</p>		<p>Photo #:</p>	<ul style="list-style-type: none"> • Reconfigure or replace handrails • •
<p>1.33 If the handrail gripping surface is circular, is it no less than 1 ¼ inches and no greater than 2 inches in diameter?</p>	<p><input type="checkbox"/> Yes <input type="checkbox"/> No</p> <p>Measurement:</p>		<p>Photo #:</p>	<ul style="list-style-type: none"> • Replace handrails • •

<p>1.34 If the handrail gripping surface is non-circular, is it no less than 4 inches and no greater than 6 ½ inches in perimeter and no more than 2 ¼ inches in cross section?</p>	<p><input type="checkbox"/> Yes <input type="checkbox"/> No</p> <p>Measurement:</p>		<p>Photo #:</p>	<ul style="list-style-type: none"> • Replace handrails • •
<p>1.35 Does the handrail: Extend at least 12 inches horizontally beyond the top and bottom of the ramp? Return to a wall, guard, or landing surface?</p>	<p><input type="checkbox"/> Yes <input type="checkbox"/> No</p> <p>Measurement:</p> <p><input type="checkbox"/> Yes <input type="checkbox"/> No</p>		<p>Photo #:</p>	<ul style="list-style-type: none"> • Add extensions • Reconfigure handrails •
<p>1.36 To prevent wheelchair casters and crutch tips from falling off: Does the surface of the ramp extend at least 12 inches beyond the inside face of the handrail? Or Is there a curb or barrier that prevents the passage of a 4-inch diameter sphere?</p>	<p><input type="checkbox"/> Yes <input type="checkbox"/> No</p> <p>Measurement:</p> <p><input type="checkbox"/> Yes <input type="checkbox"/> No</p> <p>Measurement:</p>		<p>Photo #:</p>	<ul style="list-style-type: none"> • Add curb • Add barrier • Extend ramp width •
<p>Entrance (2010 Standards – 404)</p>				
<p>1.37 Is the main entrance accessible?</p>	<p><input type="checkbox"/> Yes <input checked="" type="checkbox"/> No</p>		<ul style="list-style-type: none"> • ACCESSIBLE FROM PARKING. • Needs slope correction. • Limited to 2 spaces, could expand. • Entry Door Modification Model <p>Photo #:</p>	<ul style="list-style-type: none"> • Redesign to make it accessible • •

<p>1.38 If the main entrance is not accessible, is there an alternative accessible entrance?</p> <p>Can the alternative accessible entrance be used independently and during the same hours as the main entrance?</p>	<p><input type="checkbox"/> Yes <input checked="" type="checkbox"/> No</p> <p><input type="checkbox"/> Yes <input type="checkbox"/> No</p>		<p>• NO ALTERNATE ENTRANCE</p> <p>Photo #:</p>	<ul style="list-style-type: none"> • Designate an entrance and make it accessible • Ensure that accessible entrance can be used independently and during the same hours as the main entrance •
<p>1.39 Do all inaccessible entrances have signs indicating the location of the nearest accessible entrance?</p>	<p><input type="checkbox"/> Yes <input type="checkbox"/> No</p>		<p>NA</p> <p>Photo #:</p>	<ul style="list-style-type: none"> • Install signs • Install signs on route before people get to inaccessible entrances so that people do not have to turn around and retrace route •
<p>1.40 If not all entrances are accessible, is there a sign at the accessible entrance with the International Symbol of Accessibility?</p>	<p><input type="checkbox"/> Yes <input type="checkbox"/> No</p>		<p>NA</p> <p>Photo #:</p>	<ul style="list-style-type: none"> • Install sign • •

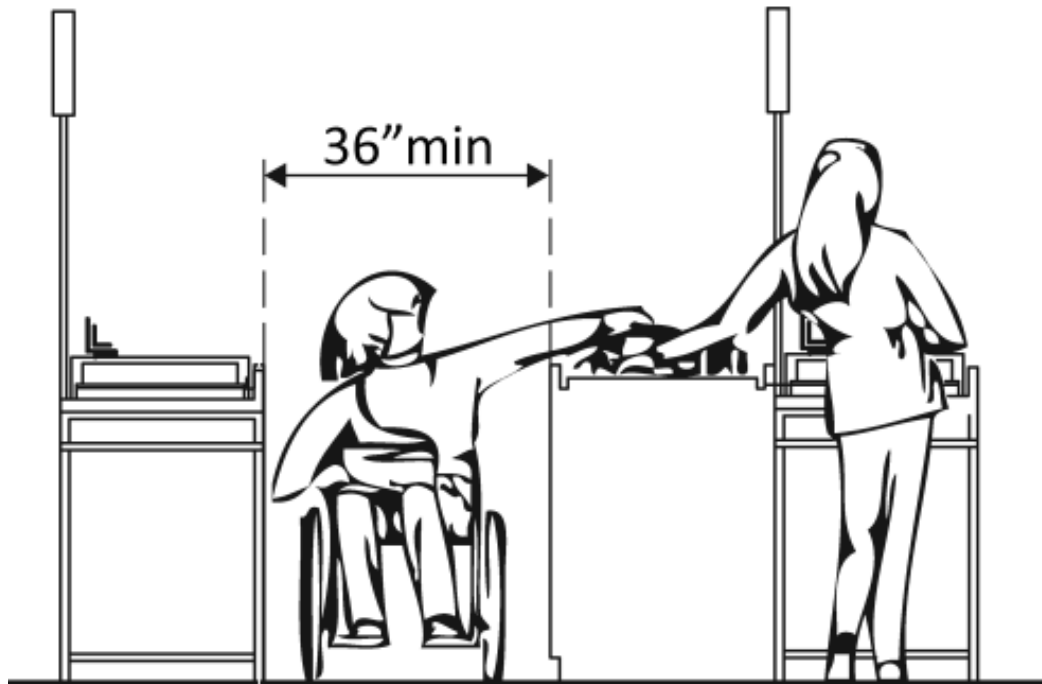
<p>1.41 Is the clear opening width of the accessible entrance door at least 32 inches, between the face of the door and the stop, when the door is open 90 degrees?</p>	<p><input checked="" type="checkbox"/> Yes <input type="checkbox"/> No</p> <p>Measurement:</p> <p>32"</p>		<p>Photo #: 3</p>	<ul style="list-style-type: none"> • Alter door • Install offset hinges •
<p>1.42 If there is a front approach to the pull side of the door, is there at least 18 inches of maneuvering clearance beyond the latch side plus at least 60 inches clear depth?</p> <p>On both sides of the door, is the ground or floor surface of the maneuvering clearance level (no steeper than 1:48)?</p>	<p><input type="checkbox"/> Yes <input checked="" type="checkbox"/> No</p> <p>Measurement:</p> <p>NA</p> <p><input checked="" type="checkbox"/> Yes <input type="checkbox"/> No</p> <p>Measurement:</p> <p>NA</p>		<p>• Note with wind screen front door is side approach. 54" is required, with closer 59" provided.</p> <p>Photo #: 4</p>	<p>See 2010 Standards 404.2.4 for maneuvering clearance requirements on the push side of the door and side approaches to the pull side of the door</p> <ul style="list-style-type: none"> • Remove obstructions • Reconfigure walls • Add automatic door opener
<p>1.43 Is the door threshold edge no more than ¼ inch high?</p> <p>Or</p> <p>No more than ¾ inch high if slope is beveled no steeper than 1:2?</p> <p>Note: The first ¼ inch of the threshold may be vertical; the rest must be beveled.</p>	<p><input checked="" type="checkbox"/> Yes <input type="checkbox"/> No</p> <p>Measurement:</p> <p>FLUSH</p> <p><input type="checkbox"/> Yes <input type="checkbox"/> No</p> <p>Measurement:</p> <p>< ¾"</p>		<p>Photo #: 3</p>	<ul style="list-style-type: none"> • Remove or replace threshold • •

<p>1.44 Is the door equipped with hardware, including locks, that is operable with one hand and does not require tight grasping, pinching, or twisting of the wrist?</p>	<p><input type="checkbox"/> Yes <input checked="" type="checkbox"/> No</p>		<p>• Pull Side Handle</p> <p>Photo #: 5</p>	<ul style="list-style-type: none"> • Replace inaccessible knob with lever, loop or push hardware • Add automatic door opener •
<p>1.45 Are the operable parts of the door hardware no less than 34 inches and no greater than 48 inches above the floor or ground surface?</p>	<p><input checked="" type="checkbox"/> Yes <input type="checkbox"/> No</p> <p>Measurement:</p>		<p>44" TO CENTER LINE</p> <p>Photo #: 6</p>	<ul style="list-style-type: none"> • Change hardware height • •
<p>1.46 If the door has a closer, does it take at least 5 seconds to close from an open position of 90 degrees to a position of 12 degrees from the latch?</p>	<p><input type="checkbox"/> Yes <input checked="" type="checkbox"/> No</p> <p>Measurement:</p> <p>BROKEN</p>		<p>• Broken closer, high force.</p> <p>Photo #:</p>	<ul style="list-style-type: none"> • Adjust closer • •
<p>1.47 If there are two doors in a series, e.g. vestibule, is the distance between the doors at least 48 inches plus the width of the doors when swinging into the space?</p>	<p><input type="checkbox"/> Yes <input type="checkbox"/> No</p> <p>Measurement:</p>		<p>NA</p>	<ul style="list-style-type: none"> • Remove inner door • Change door swing •

		<p style="text-align: center;">48" min</p> <p style="text-align: center;">or</p> <p style="text-align: center;">48" min</p>	<p>Photo #:</p>	
<p>1.48 If provided at the building entrance, are carpets or mats no higher than ½ inch thick?</p>	<p><input checked="" type="checkbox"/> Yes <input type="checkbox"/> No</p> <p>Measurement:</p>	<p style="text-align: center;">½" max</p>	<p>Photo #: 7</p>	<ul style="list-style-type: none"> • Replace or remove mats • •
<p>1.49 Are edges of carpets or mats securely attached to minimize tripping hazards?</p>	<p><input checked="" type="checkbox"/> Yes <input type="checkbox"/> No</p>		<ul style="list-style-type: none"> • Rubber Board – non slip <p>Photo #: 7</p>	<ul style="list-style-type: none"> • Secure carpeting or mats at edges • •

ADA Checklist for Readily Achievable Barrier Removal

Priority 2 – Access to Goods & Services



Project **SDDOT Rest Area Improvements**
FHU Reference Number 13-039-01
TSP Project Number 03120855

Building **TILFORD EAST**

Location **90 E., MRM 41**

Date **09-19-2013 (Inspection)**

Surveyors **Timothy Roach, AIA**
Todd Schultz, PE

Contact Information **TSP – (605) 343-6102**

The layout of the building should allow people with disabilities to obtain goods and services and to participate in activities without assistance.



Institute for Human Centered Design
www.HumanCenteredDesign.org

November 2011



ADA National Network
Questions on the ADA 800-949-4232 voice/tty

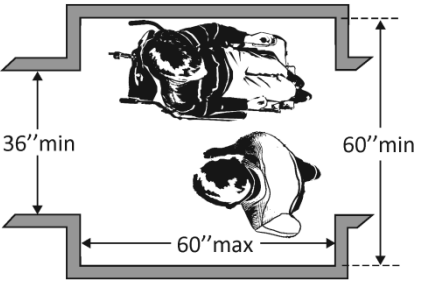
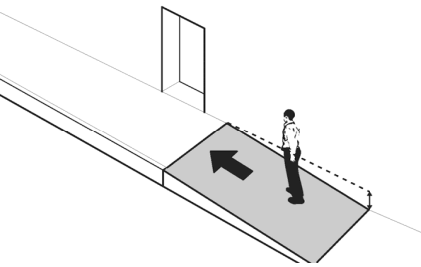
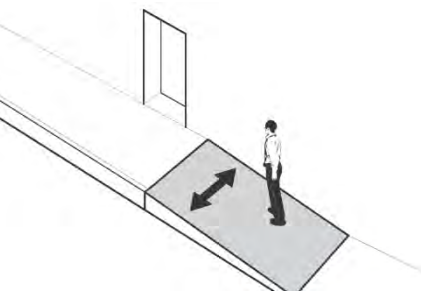

www.ADAchecklist.org

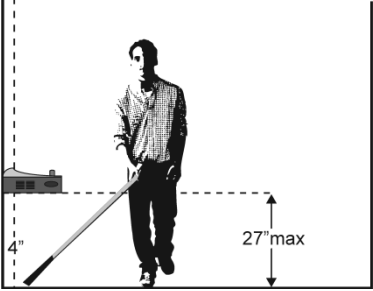
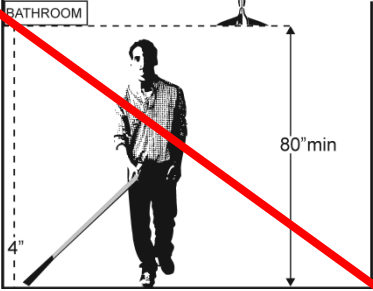
This checklist was produced by the New England ADA Center, a project of the Institute for Human Centered Design and a member of the ADA National Network. This checklist was developed under a grant from the Department of Education, NIDRR grant number H133A060092-09A. However the contents do not necessarily represent the policy of the Department of Education, and you should not assume endorsement by the Federal Government.

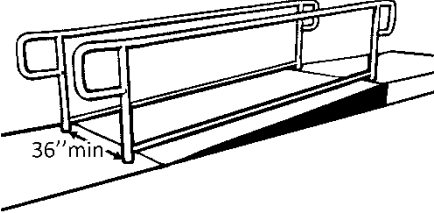
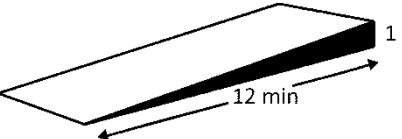
Questions or comments on the checklist contact the New England ADA Center at 617-695-0085 voice/tty or ADAinfo@NewEnglandADA.org

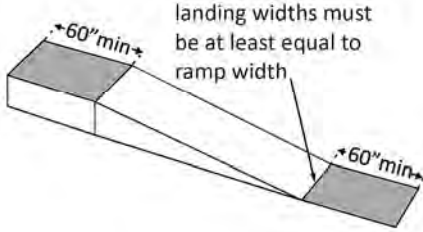
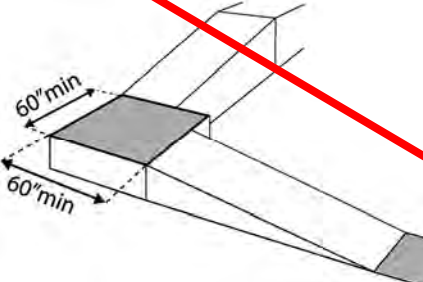
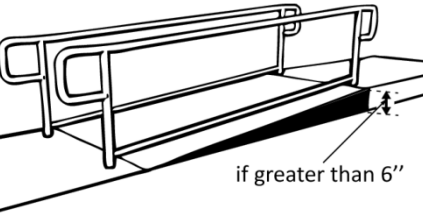
For the full set of checklists, including the checklists for recreation facilities visit www.ADAchecklist.org.

Priority 2 – Access to Goods & Services		Comments	Possible Solutions
<p>2.1 Does the accessible entrance provide direct access to the main floor, lobby and elevator?</p>	<input checked="" type="checkbox"/> Yes <input type="checkbox"/> No	<p>Photo #: 6</p>	<ul style="list-style-type: none"> • Create accessible route • •
Interior Accessible Route (2010 Standards – Ch.4)			
<p>2.2 Are all public spaces on at least one accessible route?</p>	<input checked="" type="checkbox"/> Yes <input type="checkbox"/> No	<p>Photo #: 6</p>	<ul style="list-style-type: none"> • Create accessible route • •
<p>2.3 Is the route stable, firm and slip-resistant?</p>	<input checked="" type="checkbox"/> Yes <input type="checkbox"/> No	<p>Yes, tile floors</p> <p>Photo #: 13</p>	<ul style="list-style-type: none"> • Repair uneven surfaces • •
<p>2.4 Is the route at least 36 inches wide?</p> <p>Note: The accessible route can narrow to 32 inches min. for a max. of 24 inches. These narrower portions of the route must be at least 48 inches from each other.</p>	<input checked="" type="checkbox"/> Yes <input type="checkbox"/> No	<p>Measurement: Men & Women's 39" + 34" @ Door Jam</p>	<p>Photo #:</p> <ul style="list-style-type: none"> • Widen route • •

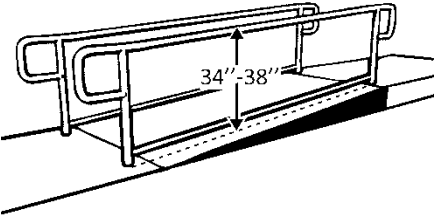
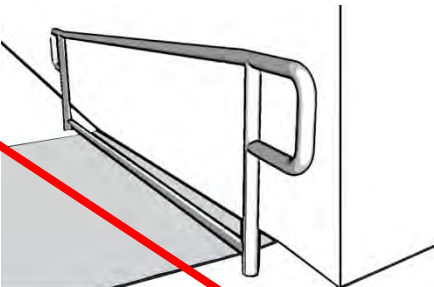
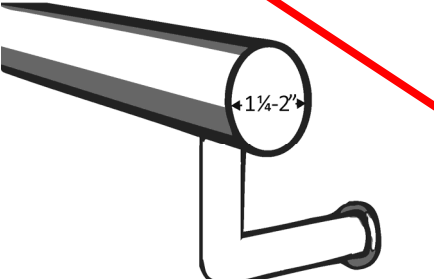
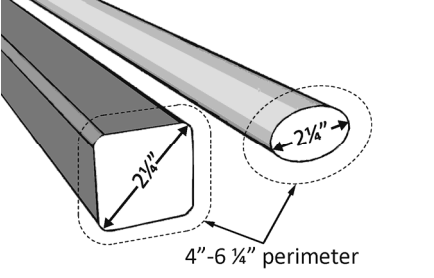
<p>2.5 If the route is greater than 200 feet in length and no less than 36 inches wide, is there a passing space no less than 60 x 60 inches?</p>	<p><input type="checkbox"/> Yes <input checked="" type="checkbox"/> No</p> <p>Measurement:</p>		<p>Photo #:</p> <p style="text-align: center;">NA</p>	<ul style="list-style-type: none"> • Widen route for passing space • •
<p>2.6 Is the running slope no steeper than 1:20, i.e. for every inch of height change there are at least 20 inches of route run?</p>	<p><input type="checkbox"/> Yes <input checked="" type="checkbox"/> No</p> <p>Measurement:</p>		<p>Photo #:</p> <p style="text-align: center;">NA</p>	<ul style="list-style-type: none"> • Regrade • If steeper than 1:20 and no steeper than 1:12, treat as ramp and add other features such as edge protection and handrails •
<p>2.7 Is the cross slope no steeper than 1:48?</p>	<p><input type="checkbox"/> Yes <input checked="" type="checkbox"/> No</p> <p>Measurement:</p>		<p>Photo #:</p> <p style="text-align: center;">NA</p>	<ul style="list-style-type: none"> • Regrade • •
<p>2.8 Do all objects on circulation paths through public areas, e.g. fire extinguishers, drinking fountains, signs, etc., protrude no more than 4 inches into the path? Or If an object protrudes more than 4 inches, is the bottom</p>	<p><input type="checkbox"/> Yes <input checked="" type="checkbox"/> No</p> <p>Measurement:</p> <p><input type="checkbox"/> Yes <input type="checkbox"/> No</p>		<p>Photo #:</p> <p style="text-align: center;">NA</p>	<ul style="list-style-type: none"> • Remove object • Add tactile warning such as permanent planter or partial walls •

<p>leading edge at 27 inches or lower above the floor? Or Is the bottom leading edge at 80 inches or higher above the floor?</p>	<p>Measurement: <input type="checkbox"/> Yes <input type="checkbox"/> No</p> <p>Measurement:</p>	<p>Or</p>  <p>Or</p> 	<p>Photo #:</p>	
<p>2.9 Are there elevators or platform lifts to all public stories?*</p>	<p><input type="checkbox"/> Yes <input type="checkbox"/> No</p>			<p>*Vertical access is not required in new construction or alterations if a facility is less than three stories or has less than 3,000 square feet per story, unless a facility is a shopping center, shopping mall, professional office of a health care provider, transportation terminal, state facility or government facility</p>

				<ul style="list-style-type: none"> • Install if necessary • Offer goods and services on an accessible story •
Ramps (2010 Standards 404 & 505)				
2.10 If there is a ramp, is it at least 36 inches wide? If there are handrails, measure between the handrails.	<input type="checkbox"/> Yes <input type="checkbox"/> No Measurement:		Photo #:	<ul style="list-style-type: none"> • Alter ramp • •
2.11 Is the surface stable, firm and slip resistant?	<input type="checkbox"/> Yes <input type="checkbox"/> No		Photo #:	<ul style="list-style-type: none"> • Change surface • •
2.12 For each section of the ramp, is the running slope no greater than 1:12, i.e. for every inch of height change there are at least 12 inches of ramp run? Note: Rises no greater than 3 inches with a slope no steeper than 1:8 and rises no greater than 6 inches with a slope no steeper than 1:10 are permitted when due to space limitations.	<input type="checkbox"/> Yes <input type="checkbox"/> No Measurement:		Photo #:	<ul style="list-style-type: none"> • Lengthen ramp to decrease slope • Reconfigure ramp to include switchbacks • Relocate ramp •

<p>2.13 Is there a level landing that is at least 60 inches long and at least as wide as the ramp:</p> <p>At the top of the ramp?</p> <p>At the bottom of the ramp?</p>	<p><input type="checkbox"/> Yes <input type="checkbox"/> No</p> <p>Measurement:</p> <p><input type="checkbox"/> Yes <input type="checkbox"/> No</p> <p>Measurement:</p>		<p>Photo #:</p>	<ul style="list-style-type: none"> • Alter ramp • Relocate ramp •
<p>2.14 Is there a level landing where the ramp changes direction that is at least 60 x 60 inches?</p>	<p><input type="checkbox"/> Yes <input type="checkbox"/> No</p> <p>Measurement:</p>		<p>Photo #:</p>	<ul style="list-style-type: none"> • Increase landing size • •
<p>2.15 If the ramp has a rise higher than 6 inches are there handrails on both sides?</p>	<p><input type="checkbox"/> Yes <input type="checkbox"/> No</p> <p>Measurement:</p>		<p>Photo #:</p>	<ul style="list-style-type: none"> • Add handrails • •

ADA Checklist for Readily Achievable Barrier Removal **Priority 2 – Access to Goods & Services**

<p>2.16 Is the top of the handrail gripping surface no less than 34 inches and no greater than 38 inches above the ramp surface?</p>	<p><input type="checkbox"/> Yes <input type="checkbox"/> No</p> <p>Measurement:</p>		<p>Photo #:</p>	<ul style="list-style-type: none"> • Adjust handrail height • •
<p>2.17 Is the handrail gripping surface continuous and not obstructed along the top or sides?</p> <p>If there are obstructions, is the bottom of the handrail gripping surface obstructed by no more than 20%?</p>	<p><input type="checkbox"/> Yes <input type="checkbox"/> No</p> <p><input type="checkbox"/> Yes <input type="checkbox"/> No</p> <p>Measurement:</p>		<p>Photo #:</p>	<ul style="list-style-type: none"> • Regrade to 1:20 max • If steeper than 1:20 and no steeper than 1:12, treat as a ramp and add other features such as edge protection and handrails •
<p>2.18 If the handrail gripping surface is circular, is it no less than 1 ¼ inches and no greater than 2 inches in diameter?</p>	<p><input type="checkbox"/> Yes <input type="checkbox"/> No</p> <p>Measurement:</p>		<p>Photo #:</p>	<ul style="list-style-type: none"> • Alter handrails • •
<p>2.19 If the handrail gripping surface is non-circular, is it no less than 4 inches and no greater than 6 ½ inches in perimeter and no more than 2 ¼ inches in cross section?</p>	<p><input type="checkbox"/> Yes <input type="checkbox"/> No</p> <p>Measurement:</p>		<p>Photo #:</p>	<ul style="list-style-type: none"> • Alter handrails • •

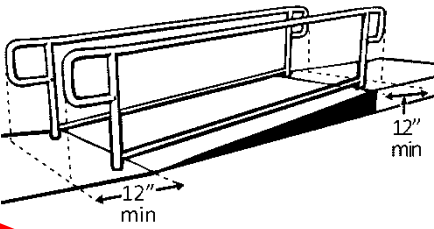
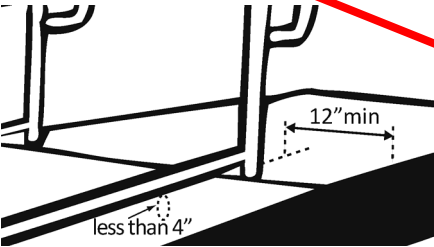
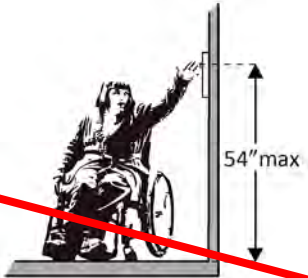
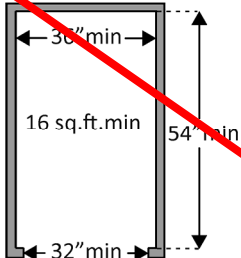
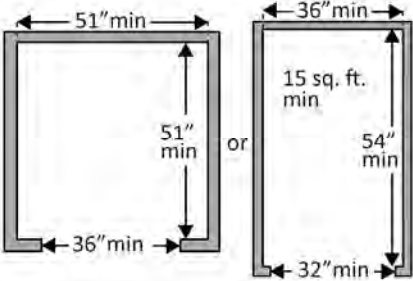
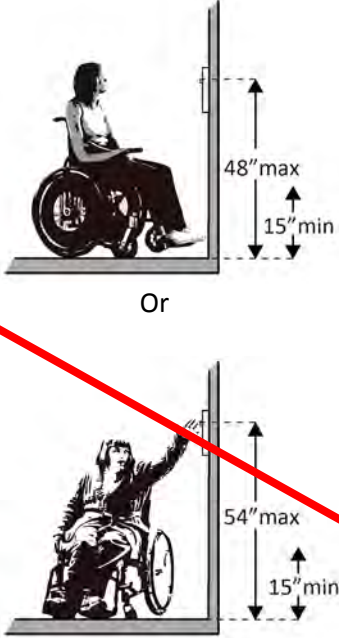

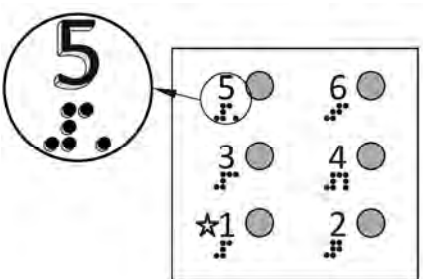
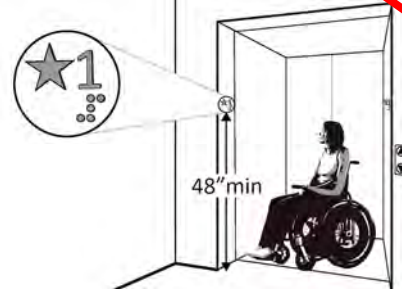

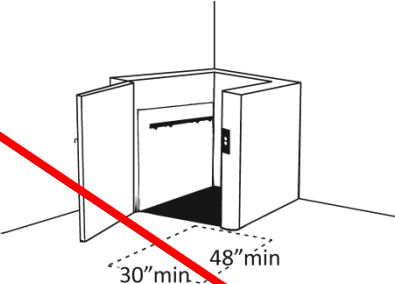
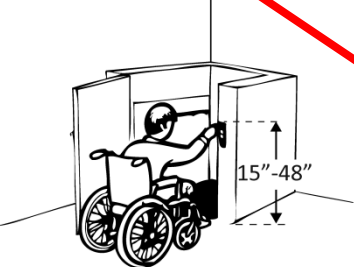
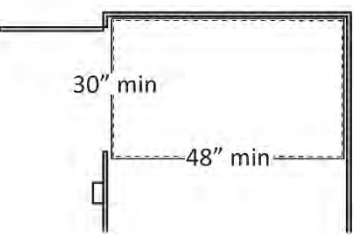
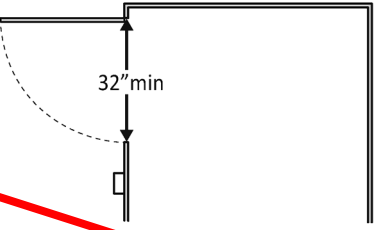
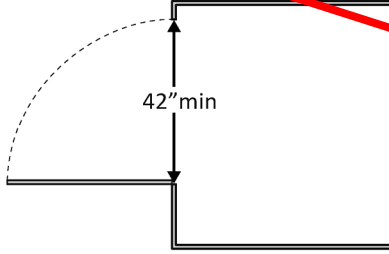
<p>2.20 Does the handrail:</p> <p>Extend at least 12 inches beyond the top and bottom of the ramp?</p> <p>Return to a wall, guard, or landing surface?</p>	<p><input type="checkbox"/> Yes <input type="checkbox"/> No</p> <p>Measurement:</p> <p><input type="checkbox"/> Yes <input type="checkbox"/> No</p>		<p>Photo #:</p>	<ul style="list-style-type: none"> • Alter handrails • • <p>If a 12" extension would be hazardous (in circulation path), it is not required</p>
<p>2.21 To prevent wheelchair casters and crutch tips from falling off:</p> <p>Does the surface of the ramp extend at least 12 inches beyond the inside face of the handrail?</p> <p>Or</p> <p>Is there a curb or barrier that prevents the passage of a 4-inch diameter sphere?</p>	<p><input type="checkbox"/> Yes <input type="checkbox"/> No</p> <p>Measurement:</p> <p><input type="checkbox"/> Yes <input type="checkbox"/> No</p> <p>Measurement:</p>		<p>Photo #:</p>	<ul style="list-style-type: none"> • Add curb • Add barrier • Extend ramp width • •
<p>Elevators – Full Size & LULA (limited use, limited application) (2010 Standards – 407 & 408) Note: LULA elevators are often used in alterations.</p>				
<p>2.22 If there is a full size or LULA elevator, are the call buttons no higher than 54 inches above the floor?</p>	<p><input type="checkbox"/> Yes <input type="checkbox"/> No</p> <p>Measurement:</p>		<p>Photo #:</p>	<ul style="list-style-type: none"> • Change call button height • •
<p>2.23 If there is a full size or LULA elevator, does the sliding door reopen automatically when obstructed by an object or person?*</p>	<p><input type="checkbox"/> Yes <input type="checkbox"/> No</p>			<p>* If constructed before 3/15/2012 and manually operated, the door is not required to reopen automatically</p>

			Photo #:	<ul style="list-style-type: none"> • Install opener •
<p>2.24 If there is a LULA elevator with a swinging door:</p> <p>Is the door power- operated? <input type="checkbox"/> Yes <input type="checkbox"/> No</p> <p>Does the door remain open for at least 20 seconds when activated? <input type="checkbox"/> Yes <input type="checkbox"/> No</p> <p>Time:</p>			Photo #:	<ul style="list-style-type: none"> • Add power operated door • Adjust opening time •
<p>2.25 If there is a full size elevator:</p> <p>Is the interior at least 54 inches deep by at least 36 inches wide with at least 16 sq. ft. of clear floor area? <input type="checkbox"/> Yes <input type="checkbox"/> No</p> <p>Measurement:</p> <p>Is the door opening width at least 32 inches? <input type="checkbox"/> Yes <input type="checkbox"/> No</p> <p>Measurement:</p>			Photo #:	<ul style="list-style-type: none"> • Replace elevator • •
<p>2.26 If there is a LULA elevator, is the interior:</p> <p>At least 51 x 51 inches with a door opening width of at least 36 inches? <input type="checkbox"/> Yes <input type="checkbox"/> No</p> <p>Measurement:</p> <p>Or</p> <p>At least 54 inches deep by at least 36 inches wide with at least 15 sq. ft. of clear floor <input type="checkbox"/> Yes <input type="checkbox"/> No</p> <p>Measurement:</p>				<ul style="list-style-type: none"> • Replace elevator • •

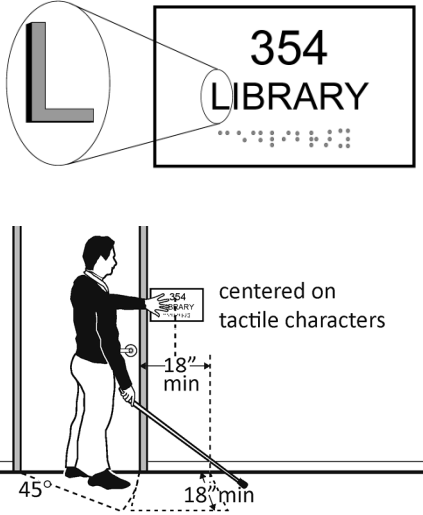
<p>area and a door opening width of at least 32 inches?</p>			Photo #:	
<p>2.27 If there is a full size or LULA elevator, are the in-car controls:</p> <p>No less than 15 inches and no greater 48 inches above the floor? Or Up to 54 inches above the floor for a parallel approach?</p>	<p><input type="checkbox"/> Yes <input type="checkbox"/> No Measurement:</p> <p><input type="checkbox"/> Yes <input type="checkbox"/> No Measurement:</p>	 <p>Or</p>	Photo #:	<ul style="list-style-type: none"> • Change control height • •
<p>2.28 If there is a LULA elevator, are the in-car controls centered on a side wall?</p>	<p><input type="checkbox"/> Yes <input type="checkbox"/> No Measurement:</p>		Photo #:	<ul style="list-style-type: none"> • Reconfigure controls • •

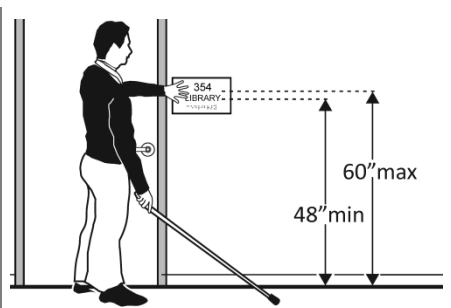
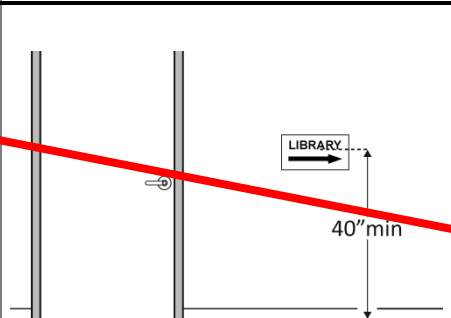
<p>2.29 If there is a full size or LULA elevator:</p> <p>Are the car control buttons designated with raised characters?</p> <p>Are the car control buttons designated with Braille?</p>	<p><input type="checkbox"/> Yes <input type="checkbox"/> No</p> <p><input type="checkbox"/> Yes <input type="checkbox"/> No</p>		<p>Photo #:</p>	<ul style="list-style-type: none"> • Add raised characters • Add Braille •
<p>2.30 If there is a full size or LULA elevator, are there audible signals which sound as the car passes or is about to stop at a floor?</p>	<p><input type="checkbox"/> Yes <input type="checkbox"/> No</p>		<p>Photo #:</p>	<ul style="list-style-type: none"> • Install audible signals • •
<p>2.31 If there is a full size or LULA elevator:</p> <p>Is there a sign on both door jambs at every floor identifying the floor?</p> <p>Is there a tactile star on both jambs at the main entry level?</p> <p>Do text characters contrast with their backgrounds?</p> <p>Are text characters raised?</p> <p>Is there Braille?</p> <p>Is the sign mounted between 48 inches to the baseline of the lowest character and 60 inches to the baseline of the highest character above the floor?*</p>	<p><input type="checkbox"/> Yes <input type="checkbox"/> No</p> <p><input type="checkbox"/> Yes <input type="checkbox"/> No</p> <p><input type="checkbox"/> Yes <input type="checkbox"/> No</p> <p><input type="checkbox"/> Yes <input type="checkbox"/> No</p> <p><input type="checkbox"/> Yes <input type="checkbox"/> No</p> <p><input type="checkbox"/> Yes <input type="checkbox"/> No</p> <p>Measurement:</p>		<p>Photo #:</p>	<ul style="list-style-type: none"> • Install signs • Change sign height • • <p>* If constructed before 3/15/2012 and mounted no higher than 60 inches to the centerline of the sign, relocation is not required</p>

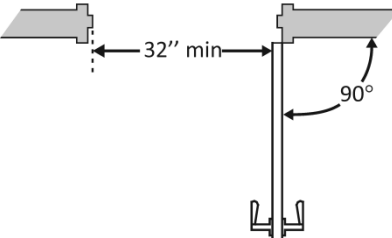
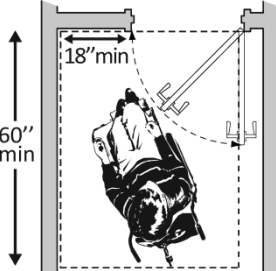
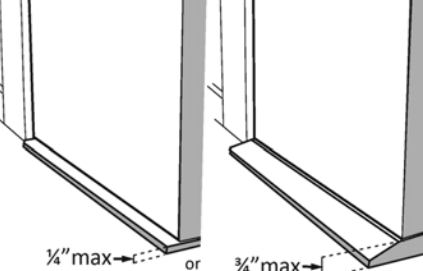
Platform Lifts (2010 Standards – 410)				
<p>2.32 If a lift is provided, can it be used without assistance from others?</p>	<p><input type="checkbox"/> Yes <input type="checkbox"/> No</p>		<p>Photo #:</p>	<ul style="list-style-type: none"> • Reconfigure so independently operable • •
<p>2.33 Is there a clear floor space at least 30 inches wide by at least 48 inches long for a person using a wheelchair to approach and reach the controls to use the lift?</p>	<p><input type="checkbox"/> Yes <input type="checkbox"/> No</p> <p>Measurement:</p>		<p>Photo #:</p>	<ul style="list-style-type: none"> • Remove obstructions • •
<p>2.34 Are the lift controls no less than 15 inches and no greater than 48 inches above the floor?</p>	<p><input type="checkbox"/> Yes <input type="checkbox"/> No</p> <p>Measurement:</p>		<p>Photo #:</p>	<ul style="list-style-type: none"> • Change control height • •
<p>2.35 Is there a clear floor space at least 30 inches wide by at least 48 inches long inside the lift?</p>	<p><input type="checkbox"/> Yes <input type="checkbox"/> No</p> <p>Measurement:</p>		<p>Photo #:</p>	<ul style="list-style-type: none"> • Replace lift • •

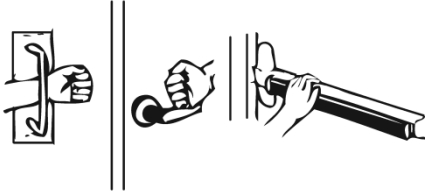
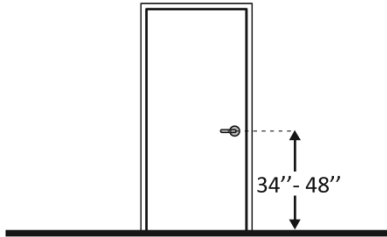
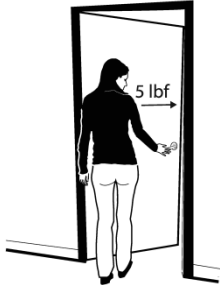
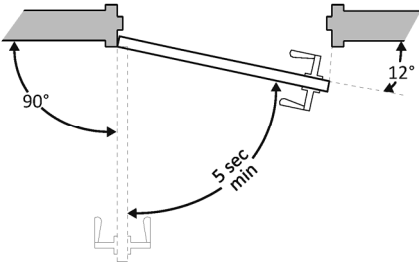
<p>2.36 If there is an end door, is the clear opening width at least 32 inches?</p>	<p><input type="checkbox"/> Yes <input type="checkbox"/> No</p> <p>Measurement:</p>		<p>Photo #:</p>	<ul style="list-style-type: none"> • Alter door width • •
<p>2.37 If there is a side door, is the clear opening width at least 42 inches?</p>	<p><input type="checkbox"/> Yes <input type="checkbox"/> No</p> <p>Measurement:</p>		<p>Photo #:</p>	<ul style="list-style-type: none"> • Alter door width • •

Signs (2010 Standards – 703) Note: “Tactile characters” are read using touch, i.e. raised characters and Braille.

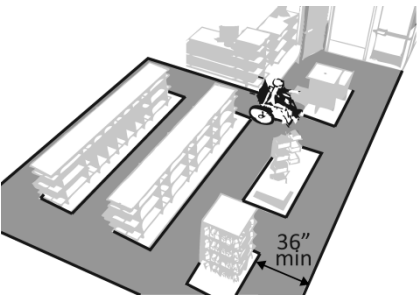
<p>2.38 If there are signs designating permanent rooms and spaces not likely to change over time, e.g. room numbers and letters, room names, and exit signs:</p> <p>Do text characters contrast with their backgrounds?</p> <p>Are text characters raised?</p> <p>Is there Braille?</p> <p>Is the sign mounted: On the wall on the latch side of the door?</p>	<p><input checked="" type="checkbox"/> Yes <input type="checkbox"/> No</p> <p><input checked="" type="checkbox"/> Yes <input type="checkbox"/> No</p> <p><input type="checkbox"/> Yes <input checked="" type="checkbox"/> No</p> <p><input type="checkbox"/> Yes <input checked="" type="checkbox"/> No</p>		<ul style="list-style-type: none"> • No 18" side clearance provided 	<ul style="list-style-type: none"> • Install tactile sign • Relocate sign •
---	---	---	---	--

<p>Note: Signs are permitted on the push side of doors with closers and without hold-open devices.</p> <p>With clear floor space beyond the arc of the door swing between the closed position and 45-degree open position, at least 18 x 18 inches centered on the tactile characters?*</p> <p>So the baseline of the lowest character is at least 48 inches above the floor and the baseline of the highest character is no more than 60 inches above the floor? *</p> <p>Note: If the sign is at double doors with one active leaf, the sign should be on the inactive leaf; if both leaves are active, the sign should be on the wall to the right of the right leaf.</p>	<p><input checked="" type="checkbox"/> Yes <input type="checkbox"/> No</p> <p>Measurement:</p> <p><input type="checkbox"/> Yes <input type="checkbox"/> No</p> <p>Measurement:</p> <p>Signs ok @ Men's and Women's</p>		<p>Photo #: 8 Women's & Men's Similar</p>	<p>*If constructed before 3/15/2010 and a person may approach within 3 inches of the sign without encountering protruding objects or standing within the door swing, relocation not required</p> <p>*If constructed before 3/15/2012 and mounted no higher than 60 inches to the centerline of the sign, relocation not required</p>
<p>2.39 If there are signs that provide direction to or information about interior spaces:</p> <p>Do text characters contrast with their backgrounds?</p> <p>Is the sign mounted so that characters are at least 40 inches above the floor?</p>	<p><input type="checkbox"/> Yes <input type="checkbox"/> No</p> <p><input type="checkbox"/> Yes <input type="checkbox"/> No</p> <p>Measurement:</p>		<p>Photo #:</p>	<p>• Install signs with contrasting characters</p> <p>• Change sign height</p> <p>•</p> <p>Raised characters and Braille are not required</p>


Interior Doors – to classrooms, medical exam rooms, conference rooms, etc. (2010 Standards – 404)				
<p>2.40 Is the door opening width at least 32 inches clear, between the face of the door and the stop, when the door is open 90 degrees?</p>	<p><input checked="" type="checkbox"/> Yes <input type="checkbox"/> No</p> <p>Measurement:</p> <p>34 +” to restrooms</p>		<p>Photo #: 10 Men & similar in Women’s</p>	<ul style="list-style-type: none"> • Install offset hinges • Alter the doorway •
<p>2.41 If there is a front approach to the pull side of the door, is there at least 18 inches of maneuvering clearance beyond the latch side plus at least 60 inches clear depth?</p> <p>On both sides of the door, is the floor surface of the maneuvering clearance level (no steeper than 1:48)?</p>	<p><input type="checkbox"/> Yes <input checked="" type="checkbox"/> No</p> <p>Measurement:</p> <p>NA</p> <p><input type="checkbox"/> Yes <input type="checkbox"/> No</p> <p>Measurement:</p>		<p>Photo #: 9</p>	<ul style="list-style-type: none"> • Remove obstructions • Reconfigure walls • Add automatic door opener <p>See 2010 Standards 404.2.4 for maneuvering clearance requirements on the push side of the door and side approaches to the pull side of the door</p>
<p>2.42 Is the door threshold edge no more than ¼ inch high?</p> <p>Or</p> <p>No more than ¾ inch high if slope is beveled no steeper than 1:2?</p> <p>Note: The first ¼ inch of the threshold may be vertical; the rest must be beveled.</p>	<p><input checked="" type="checkbox"/> Yes <input type="checkbox"/> No</p> <p>Measurement:</p> <p><input type="checkbox"/> Yes <input type="checkbox"/> No</p> <p>Measurement:</p>		<ul style="list-style-type: none"> • No Threshold in Men’s or Women’s <p>Photo #: 9 Men’s</p>	<ul style="list-style-type: none"> • Remove or replace threshold • •

<p>2.43 Is the door equipped with hardware that is operable with one hand and does not require tight grasping, pinching and twisting of the wrist?</p>	<p><input type="checkbox"/> Yes <input checked="" type="checkbox"/> No</p>		<ul style="list-style-type: none"> • 1 ½" Clearance • Similar in Men's and Women's <p>Photo #: 11 Men's</p>	<ul style="list-style-type: none"> • Replace inaccessible knob with lever, loop or push hardware • Add automatic door opener •
<p>2.44 Are the operable parts of the hardware no less than 34 inches and no greater than 48 inches above the floor?</p>	<p><input checked="" type="checkbox"/> Yes <input type="checkbox"/> No</p> <p>Measurement: Pull Handle 38" Center Line for both Men's & Women's</p>		<p>Photo #: 11</p>	<ul style="list-style-type: none"> • Change hardware height • •
<p>2.45 Can the door be opened easily (5 pounds maximum force)?</p> <p>Note: You can use a pressure gauge or fish scale to measure force. If you do not have a pressure gauge or fish scale you will need to judge whether the door is easy to open.</p>	<p><input type="checkbox"/> Yes <input checked="" type="checkbox"/> No</p> <p>Measurement: 10 lbs for both Men's & Women's</p>		<p>Photo #:</p>	<ul style="list-style-type: none"> • Adjust or replace closers • Install lighter doors • Install power-assisted or automatic door openers
<p>2.46 If the door has a closer, does it take at least 5 seconds to close from an open position of 90 degrees to a position of 12 degrees from the latch?</p>	<p><input checked="" type="checkbox"/> Yes <input type="checkbox"/> No</p> <p>Measurement:</p>		<p>Photo #:</p>	<ul style="list-style-type: none"> • Adjust closer • •

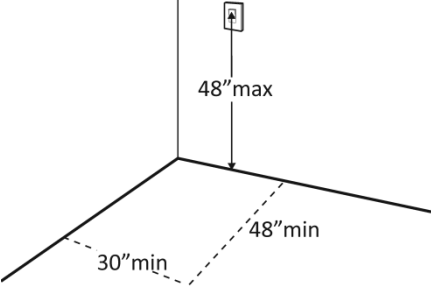
Rooms and Spaces – stores, supermarkets, libraries, etc. (2010 Standards – 302, 304, & 402)

<p>2.47 Are aisles and pathways to goods and services, and to one of each type of sales and service counters, at least 36 inches wide?</p>	<p><input checked="" type="checkbox"/> Yes <input type="checkbox"/> No</p> <p>Measurement:</p>		<p>• No Display Racks are out</p> <p>Photo #:</p>	<ul style="list-style-type: none"> • Rearrange goods, equipment and furniture • •
---	--	--	--	--

<p>2.48 Are floor surfaces stable, firm and slip resistant?</p>	<p><input checked="" type="checkbox"/> Yes <input type="checkbox"/> No</p>		<p>• Red Floor tile/worn</p> <p>Photo #:</p>	<ul style="list-style-type: none"> • Change floor surface • •
--	--	--	---	--

<p>2.49 If there is carpet:</p> <p>Is it no higher than ½ inch?</p> <p>Is it securely attached along the edges?</p>	<p><input type="checkbox"/> Yes <input checked="" type="checkbox"/> No</p> <p>Measurement:</p> <p><input type="checkbox"/> Yes <input type="checkbox"/> No</p>		<p>Photo #:</p>	<ul style="list-style-type: none"> • Replace carpet • •
--	--	--	-----------------	--

Controls – light switches, security and intercom systems, emergency/alarm boxes, etc. (2010 Standards – 309)

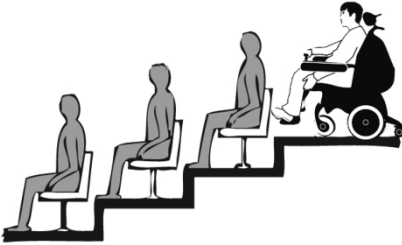
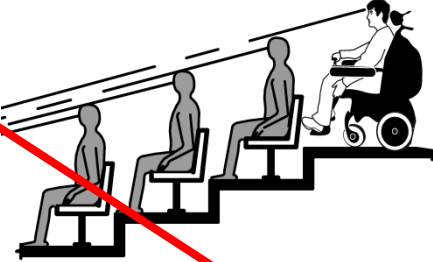
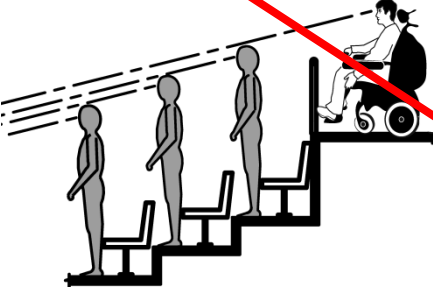

<p>2.50 Is there a clear floor space at least 30 inches wide by at least 48 inches long for a forward or parallel approach?</p> <p>Are the operable parts no higher than 48 inches above the floor?*</p>	<p><input type="checkbox"/> Yes <input type="checkbox"/> No</p> <p>Measurement:</p> <p><input type="checkbox"/> Yes <input type="checkbox"/> No</p> <p>Measurement:</p>		<p>• None in public spaces</p>	<ul style="list-style-type: none"> • Change height of control • • <p>*If constructed before 3/15/2012 and a parallel approach is provided, controls can be 54 inches</p>
---	---	--	---------------------------------------	---

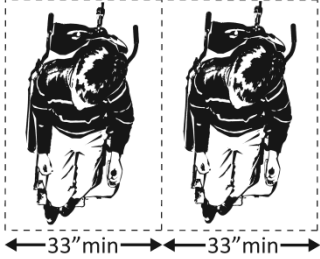
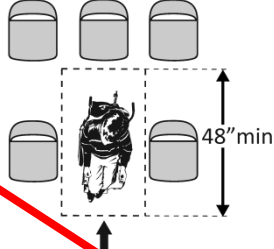
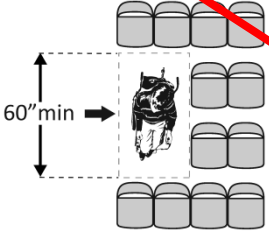
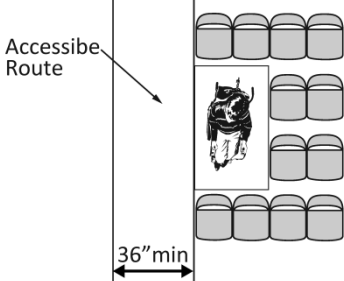
			above the floor
			Photo #:

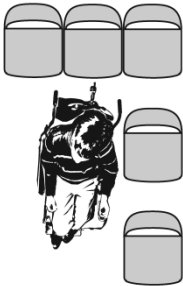

<p>2.51 Can the control be operated with one hand and without tight grasping, pinching, or twisting of the wrist?</p>	<input checked="" type="checkbox"/> Yes <input type="checkbox"/> No		<p>Photo #:</p> <ul style="list-style-type: none"> • Replace control • •
--	---	--	---

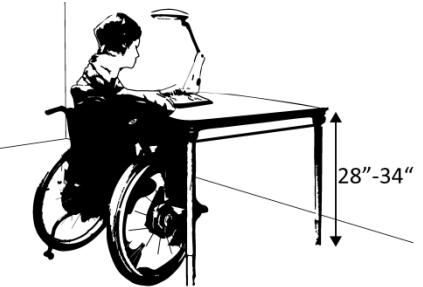
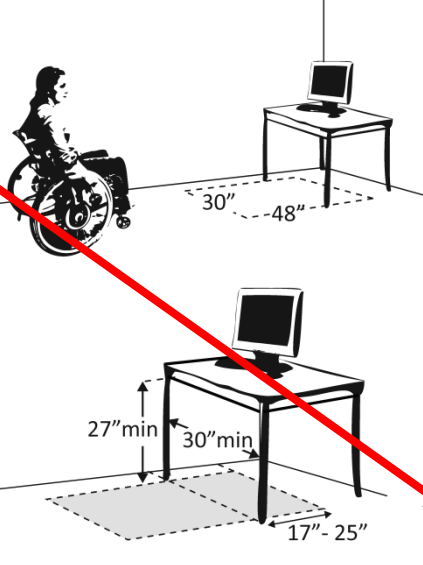
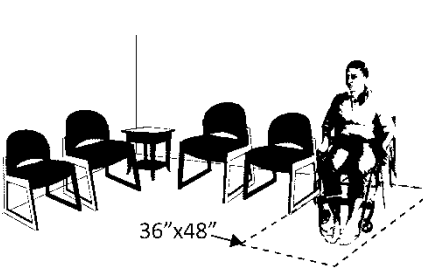
Seating: Assembly Areas – theaters, auditoriums, stadiums, theater style classrooms, etc. (2010 Standards – 221 & 802)

<p>2.52 Are an adequate number of wheelchair spaces provided?</p>	<input type="checkbox"/> Yes <input type="checkbox"/> No	<table border="1"> <thead> <tr> <th># of Seats</th> <th>Wheelchair Spaces</th> </tr> </thead> <tbody> <tr> <td>4 - 25</td> <td>1</td> </tr> <tr> <td>26 - 50</td> <td>2</td> </tr> <tr> <td>51 - 150</td> <td>4</td> </tr> <tr> <td>151 - 300</td> <td>5</td> </tr> <tr> <td colspan="2">300+ see 2010 Standards 221.2.1.</td> </tr> </tbody> </table>	# of Seats	Wheelchair Spaces	4 - 25	1	26 - 50	2	51 - 150	4	151 - 300	5	300+ see 2010 Standards 221.2.1.		<p>Photo #:</p> <ul style="list-style-type: none"> • Reconfigure to add wheelchair spaces • •
# of Seats	Wheelchair Spaces														
4 - 25	1														
26 - 50	2														
51 - 150	4														
151 - 300	5														
300+ see 2010 Standards 221.2.1.															

<p>2.53 Are wheelchair spaces dispersed to allow location choices and viewing angles equivalent to other seating, including specialty seating areas that provide distinct services and amenities?</p>	<p><input type="checkbox"/> Yes <input type="checkbox"/> No</p>		<p>Photo #:</p>	<ul style="list-style-type: none"> • Reconfigure to disperse wheelchair spaces • •
<p>2.54 Where people are expected to remain seated, do people in wheelchair spaces have a clear line of sight over and between the heads of others in front of them?</p>	<p><input type="checkbox"/> Yes <input type="checkbox"/> No</p>		<p>Photo #:</p>	<ul style="list-style-type: none"> • Alter for line of sight • •
<p>2.55 Where people are expected to stand, do people in wheelchair spaces have a clear line of sight over and between the heads of others in front of them?</p>	<p><input type="checkbox"/> Yes <input type="checkbox"/> No</p>		<p>Photo #:</p>	<ul style="list-style-type: none"> • Alter for line of sight • •
<p>2.56 If there is a single wheelchair space, is it at least 36 inches wide?</p>	<p><input type="checkbox"/> Yes <input type="checkbox"/> No</p> <p>Measurement:</p>		<p>Photo #:</p>	<ul style="list-style-type: none"> • Alter space • •

<p>2.57 If there are two adjacent wheelchair spaces, are they each at least 33 inches wide?</p>	<p><input type="checkbox"/> Yes <input type="checkbox"/> No</p> <p>Measurement:</p>		<p>Photo #:</p>	<ul style="list-style-type: none"> • Alter spaces • •
<p>2.58 If the wheelchair space can be entered from the front or rear, is it at least 48 inches deep?</p>	<p><input type="checkbox"/> Yes <input type="checkbox"/> No</p> <p>Measurement:</p>		<p>Photo #:</p>	<ul style="list-style-type: none"> • Alter space • •
<p>2.59 If the wheelchair space can only be entered from the side, is it at least 60 inches deep?</p>	<p><input type="checkbox"/> Yes <input type="checkbox"/> No</p> <p>Measurement:</p>		<p>Photo #:</p>	<ul style="list-style-type: none"> • Alter space • •
<p>2.60 Do wheelchair spaces adjoin, but not overlap, accessible routes?</p>	<p><input type="checkbox"/> Yes <input type="checkbox"/> No</p>	<p>Accessible Route</p> 	<p>Photo #:</p>	<ul style="list-style-type: none"> • Alter spaces • •

<p>2.61 Is there at least one companion seat for each wheelchair space?</p>	<p><input type="checkbox"/> Yes <input type="checkbox"/> No</p>		<p>Photo #:</p>	<ul style="list-style-type: none"> • Add companion seats • •
<p>2.62 Is the companion seat located so the companion is shoulder-to-shoulder with the person in a wheelchair?</p>	<p><input type="checkbox"/> Yes <input type="checkbox"/> No</p>		<p>Photo #:</p>	<ul style="list-style-type: none"> • Alter seating • •
<p>2.63 Is the companion seat equivalent in size, quality, comfort and amenities to seating in the immediate area?</p>	<p><input type="checkbox"/> Yes <input type="checkbox"/> No</p>		<p>Photo #:</p>	<ul style="list-style-type: none"> • Add equivalent seating • •
<p>Seating: At dining surfaces (restaurants, cafeterias, bars, etc.) and non-employee work surfaces (libraries, conference rooms, etc.) (2010 Standards – 226 & 902)</p>				
<p>2.64 Are at least 5%, but no fewer than one, of seating and standing spaces accessible for people who use wheelchairs?</p>	<p><input type="checkbox"/> Yes <input type="checkbox"/> No</p> <p>Total #:</p> <p>Wheelchair #:</p>		<p>Photo #:</p>	<ul style="list-style-type: none"> • Alter to provide accessible spaces • •
<p>2.65 Is there a route at least 36 inches wide to accessible seating?</p>	<p><input type="checkbox"/> Yes <input type="checkbox"/> No</p> <p>Measurement:</p>		<p>Photo #:</p>	<ul style="list-style-type: none"> • Widen route • •

<p>2.66 At the accessible space(s), is the top of the accessible surface no less than 28 inches and no greater than 34 inches above the floor?</p>	<p><input type="checkbox"/> Yes <input type="checkbox"/> No</p> <p>Measurement:</p>		<p>Photo #:</p>	<ul style="list-style-type: none"> • Alter surface height • •
<p>2.67 Is there a clear floor space at least 30 inches wide by at least 48 inches long for a forward approach?</p> <p>Does it extend no less than 17 inches and no greater than 25 inches under the surface?</p> <p>Is there knee space at least 27 inches high and at least 30 inches wide?</p>	<p><input type="checkbox"/> Yes <input type="checkbox"/> No</p> <p>Measurement:</p> <p><input type="checkbox"/> Yes <input type="checkbox"/> No</p> <p>Measurement:</p> <p><input type="checkbox"/> Yes <input type="checkbox"/> No</p> <p>Measurement:</p>		<p>Photo #:</p>	<ul style="list-style-type: none"> • Alter table or work surface • Add accessible table or work surface •
<p>Seating: General – reception areas, waiting rooms, etc. (2010 Standards – 801)</p>				
<p>2.68 Is there at least one space at least 36 inches wide by at least 48 inches long for a person in a wheelchair?</p>	<p><input type="checkbox"/> Yes <input type="checkbox"/> No</p> <p>Measurement:</p>		<p>Photo #:</p>	<ul style="list-style-type: none"> • Move furniture and equipment to provide space • •

Benches – In locker rooms, dressing rooms, fitting rooms (2010 Standards – 803 & 903)

2.69 In locker rooms, dressing rooms and fitting rooms, is there at least one room with a bench?

Yes No

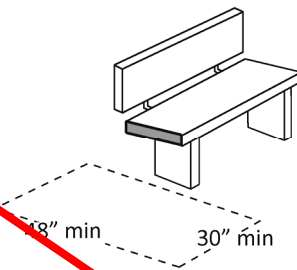
- Add bench
-
-

Photo #:

2.70 Is there a clear floor space at least 30 inches wide by at least 48 inches long at the end of the bench and parallel to the short axis of the bench?

Yes No

Measurement:

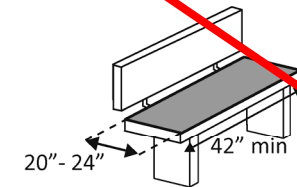


Yes No

Measurement:

Is the bench seat at least 42 inches long and no less than 20 inches and no greater than 24 inches deep?

Yes No



Does the bench have back support or is it affixed to a wall?

Yes No

Is the top of the bench seat no less than 17 inches and no greater than 19 inches above the floor?

Measurement:

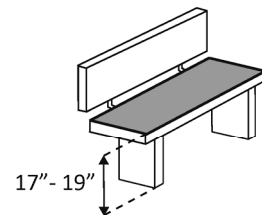
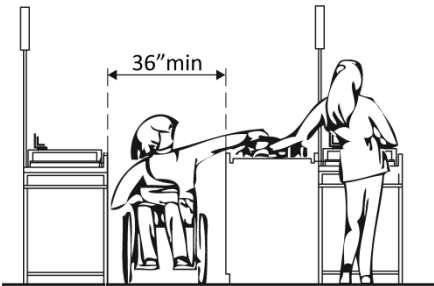
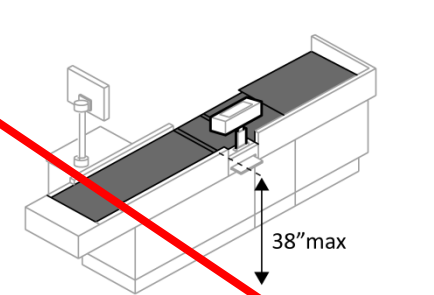
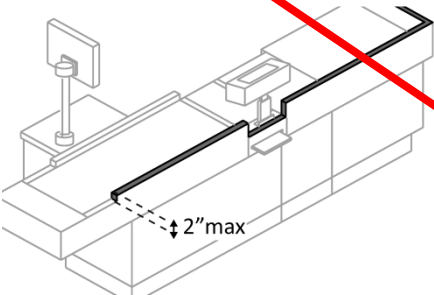
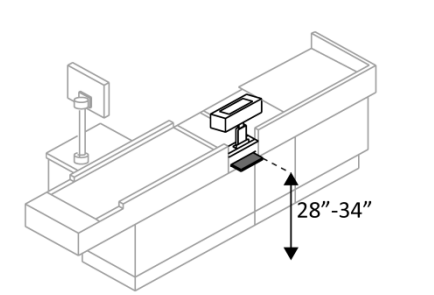
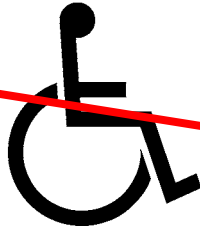


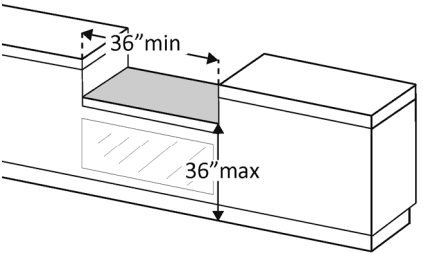
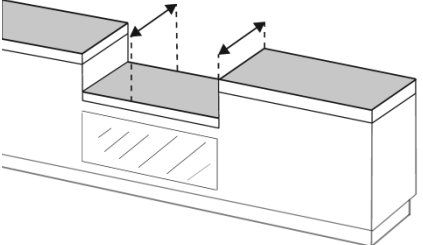
Photo #:

- Move bench
- Replace bench
- Affix bench to wall
-
-

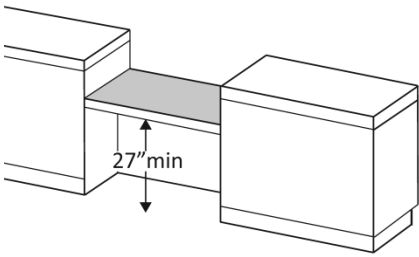
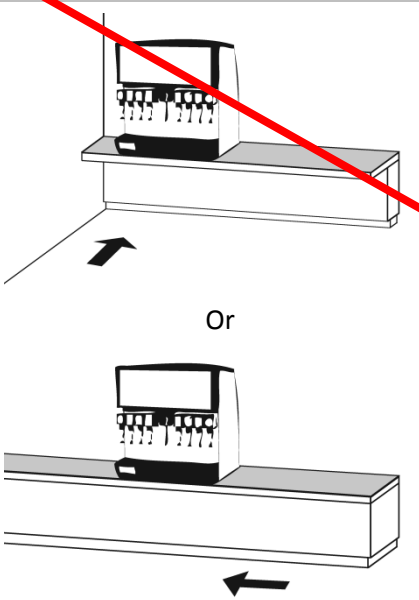
Check-Out Aisles – supermarkets, large retail stores, etc. (2010 Standards – 904)				
<p>2.71 Is the aisle at least 36 inches wide?</p>	<p><input type="checkbox"/> Yes <input type="checkbox"/> No</p> <p>Measurement:</p>	 <p>36"min</p>	<p>Photo #:</p>	<ul style="list-style-type: none"> • Widen aisle • •
<p>2.72 Is the counter surface of at least one aisle no higher than 38 inches above the floor?</p>	<p><input type="checkbox"/> Yes <input type="checkbox"/> No</p> <p>Measurement:</p>	 <p>38"max</p>	<p>Photo #:</p>	<ul style="list-style-type: none"> • Lower counter • •
<p>2.73 Is the top of the counter edge protection no higher than 2 inches above the counter surface?</p>	<p><input type="checkbox"/> Yes <input type="checkbox"/> No</p> <p>Measurement:</p>	 <p>2"max</p>	<p>Photo #:</p>	<ul style="list-style-type: none"> • Lower edge protection • •
<p>2.74 If there is a check writing surface, is the top no less than 28 inches and no greater than 34 inches above the floor?</p>	<p><input type="checkbox"/> Yes <input type="checkbox"/> No</p> <p>Measurement:</p>	 <p>28"-34"</p>	<p>Photo #:</p>	<ul style="list-style-type: none"> • Alter check writing surface • •

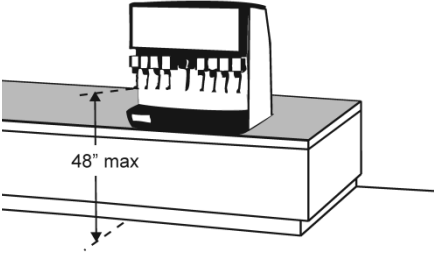
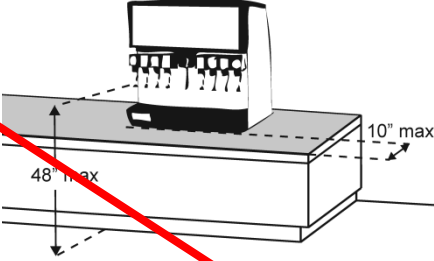
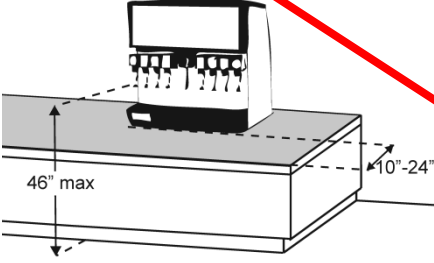
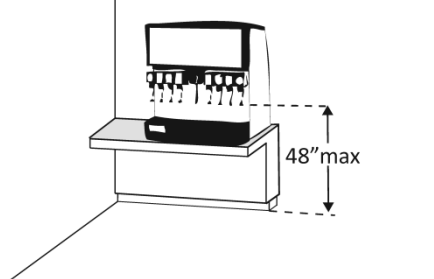
<p>2.75 If there is more than one check-out aisle is there a sign with the International Symbol of Accessibility at the accessible aisle?</p>	<p><input type="checkbox"/> Yes <input type="checkbox"/> No</p>		<p>Photo #:</p>	<ul style="list-style-type: none"> • Add sign • •
---	---	---	-----------------	--

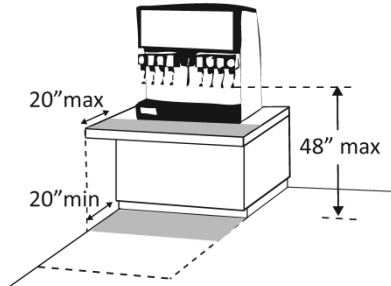
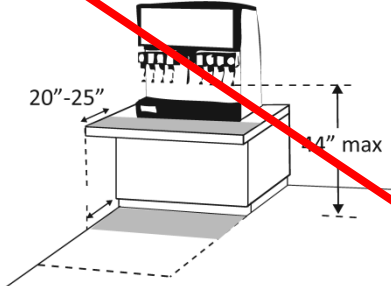
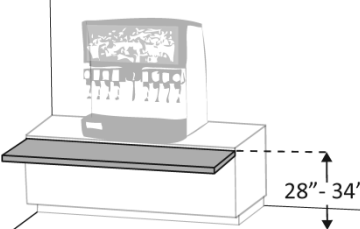
Sales & Service Counters – banks, stores, dry cleaners, auto repair shops, fitness clubs, etc. (2010 Standards – 904)

<p>2.76 Is there a portion of at least one of each type of counter that is:</p> <p>No higher than 36 inches above the floor?</p> <p>At least 36 inches long?</p>	<p><input type="checkbox"/> Yes <input checked="" type="checkbox"/> No Measurement:</p> <p><input type="checkbox"/> Yes <input checked="" type="checkbox"/> No Measurement:</p>		<p>• 2 COUNTERS</p> <p>Photo #: 12</p>	<ul style="list-style-type: none"> • Lower section of counter • Lengthen section of counter •
<p>2.77 Does the accessible portion of the counter extend the same depth as the counter top?</p>	<p><input type="checkbox"/> Yes <input checked="" type="checkbox"/> No Measurement: NA</p>		<p>Photo #:</p>	<ul style="list-style-type: none"> • Alter accessible portion • •

<p>2.78 Is there a clear floor space at least 30 inches wide by at least 48 inches long for a forward or parallel approach?</p>	<p><input type="checkbox"/> Yes <input type="checkbox"/> No</p> <p><input type="checkbox"/> Parallel Measurement:</p> <p><input type="checkbox"/> Forward Measurement:</p>		<p>Photo #:</p>	<ul style="list-style-type: none"> • Reconfigure to provide a parallel or forward approach • •
<p>2.79 For a parallel approach, is the clear floor space positioned with the 48 inches adjacent to the accessible length of counter?</p>	<p><input type="checkbox"/> Yes <input type="checkbox"/> No</p> <p>Measurement:</p>		<p>Photo #:</p>	<ul style="list-style-type: none"> • If a parallel approach is not possible, a forward approach is required • •
<p>2.80 For a forward approach:</p> <p>Do no less than 17 and no greater than 25 inches of the clear floor space extend under the accessible length of the counter?</p> <p>Is there at least 27 inches clearance from the floor to the</p>	<p><input type="checkbox"/> Yes <input type="checkbox"/> No</p> <p>Measurement:</p> <p><input type="checkbox"/> Yes <input type="checkbox"/> No</p>		<p>Photo #:</p>	<ul style="list-style-type: none"> • Reconfigure to provide knee clearance • •

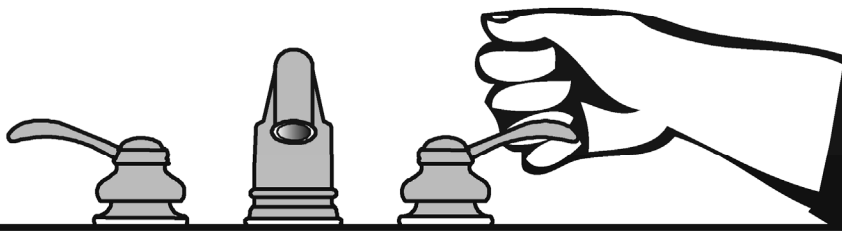
<p>bottom of the counter?</p>	<p>Measurement:</p>		<p>Photo #:</p>	
<p>Food Service Lines – in cafeterias, salad bars, eat-in fast food establishments, etc. (2010 Standards – 904)</p>				
<p>2.81 Does at least one of each type of self-service shelf or dispensing device for tableware, dishware, condiments, food and beverages have a forward or parallel approach?</p>	<p><input type="checkbox"/> Yes <input type="checkbox"/> No</p> <p><input type="checkbox"/> Forward</p> <p><input type="checkbox"/> Parallel</p>		<p>Photo #:</p>	<ul style="list-style-type: none"> • Reconfigure to provide approach • •

<p>2.82 If there is an unobstructed parallel approach, is the shelf or dispensing device no higher than 48 inches above the floor?</p>	<p><input type="checkbox"/> Yes <input type="checkbox"/> No</p> <p>Measurement:</p>		<p>Photo #:</p>	<ul style="list-style-type: none"> • Lower shelf and/or dispensing device • •
<p>2.83 If there is a shallow obstruction no deeper than 10 inches with a parallel approach, is the shelf or dispensing device no higher than 48 inches above the floor?</p>	<p><input type="checkbox"/> Yes <input type="checkbox"/> No</p> <p>Measurement:</p>		<p>Photo #:</p>	<ul style="list-style-type: none"> • Lower shelf and/or dispensing device • •
<p>2.84 If there is an obstruction no less than 10 inches and no greater than 24 inches deep with a parallel approach, is the shelf or dispensing device no higher than 46 inches above the floor?</p>	<p><input type="checkbox"/> Yes <input type="checkbox"/> No</p> <p>Measurement:</p>		<p>Photo #:</p>	<ul style="list-style-type: none"> • Lower shelf and/or dispensing device • •
<p>2.85 If there is an unobstructed forward approach, is the shelf or dispensing device no higher than 48 inches above the floor?</p>	<p><input type="checkbox"/> Yes <input type="checkbox"/> No</p> <p>Measurement:</p>		<p>Photo #:</p>	<ul style="list-style-type: none"> • Lower shelf and/or dispensing device • •

<p>2.86 If there is an obstruction no deeper than 20 inches with a forward approach:</p> <p>Does clear floor space extend under the obstruction that is at least the same depth as the obstruction?</p> <p>Is the shelf or dispensing device no higher than 48 inches above the floor?</p>	<p><input type="checkbox"/> Yes <input type="checkbox"/> No Measurement:</p> <p><input type="checkbox"/> Yes <input type="checkbox"/> No Measurement:</p>		<p>Photo #:</p>	<ul style="list-style-type: none"> • Reconfigure to provide knee space • Lower shelf and/or dispensing device •
<p>2.87 If the obstruction is no less than 20 inches and no greater than 25 inches deep with a forward approach:</p> <p>Does clear floor space extend under the obstruction that is at least the same depth as the obstruction?</p> <p>Is the shelf or dispensing device no higher than 44 inches above the floor?</p>	<p><input type="checkbox"/> Yes <input type="checkbox"/> No Measurement:</p> <p><input type="checkbox"/> Yes <input type="checkbox"/> No Measurement:</p>		<p>Photo #:</p>	<ul style="list-style-type: none"> • Reconfigure to provide knee space • Lower shelf and/or dispensing device •
<p>2.88 If there is a tray slide, is the top no less than 28 inches and no greater than 34 inches above the floor?</p>	<p><input type="checkbox"/> Yes <input type="checkbox"/> No Measurement:</p>		<p>Photo #:</p>	<ul style="list-style-type: none"> • Reconfigure • •

The ADA Checklist for Readily Achievable Barrier Removal

Priority 3 – Men's Toilet Rooms



Project **SDDOT Rest Area Improvements**
FHU Reference Number 13-039-01
TSP Project Number 03120855

Building **TILFORD EAST**

Location **90 E., MRM 41**

Date **09-19-2013 (Inspection)**

Surveyors **Timothy Roach, AIA**
Todd Schultz, PE

Contact Information **TSP – (605) 343-6102**

When toilet rooms are open to the public they should be accessible to people with disabilities.





Institute for Human Centered Design
www.HumanCenteredDesign.org

November 2011



ADA National Network
Questions on the ADA 800-949-4232 voice/tty
www.ADAchecklist.org

Priority 3 – Toilet Rooms		Comments	Possible Solutions
<p>3.1 If toilet rooms are available to the public, is at least one toilet room accessible? (Either one for each sex, or one unisex.)</p>	<input checked="" type="checkbox"/> Yes <input type="checkbox"/> No	<p>Photo #:</p>	<ul style="list-style-type: none"> • Reconfigure toilet rooms • Combine toilet rooms to create one unisex accessible toilet room •
<p>3.2 Are there signs at inaccessible toilet rooms that give directions to accessible toilet rooms?</p>	<input type="checkbox"/> Yes <input type="checkbox"/> No	 <p>Photo #:</p>	<p>NA</p> <ul style="list-style-type: none"> • Install signs • •
<p>3.3 If not all toilet rooms are accessible, is there a sign at the accessible toilet room with the International Symbol of Accessibility?</p>	<input type="checkbox"/> Yes <input type="checkbox"/> No	 <p>Photo #:</p>	<p>NA</p> <ul style="list-style-type: none"> • Install sign • •
<p>Accessible Route (2010 Standards – Chapter 4)</p>			
<p>3.4 Is there a route to the accessible toilet room(s) that does not include the use of stairs?</p>	<input checked="" type="checkbox"/> Yes <input type="checkbox"/> No	<p>Photo #: 13</p>	<ul style="list-style-type: none"> • Alter route • •
<p>Is the route accessible? (See Priority 2 Interior Accessible Route for specifics.)</p>	<input type="checkbox"/> Yes <input checked="" type="checkbox"/> No		

Signs at Toilet Rooms (2010 Standards – 703)

3.5 Do text characters contrast with their backgrounds?

Yes No

Are text characters raised?

Yes No

Is there Braille?

Yes No

Is the sign mounted:
On the wall on the latch side of the door?

Yes No

Note:

Signs are permitted on the push side of doors with closers and without hold-open devices.

With clear floor space beyond the arc of the door swing and 45-degree open position, at least 18 x 18 inches centered on the tactile characters? *

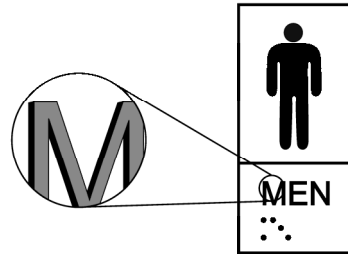
Yes No

So the baseline of the lowest character is at least 48 inches above the floor and the baseline of the highest character is no more than 60 inches above the floor? *

Yes No

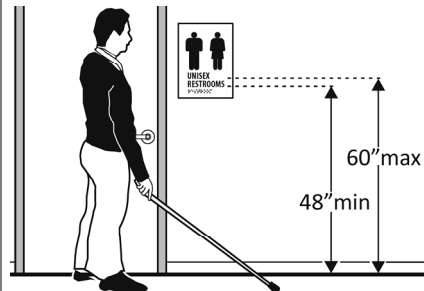
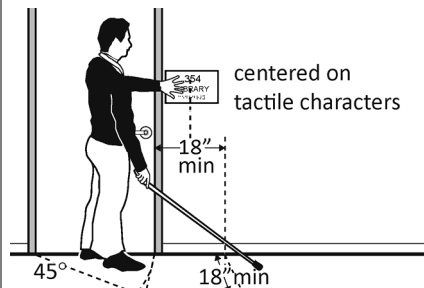
Note:

If the sign is at double doors with one active leaf, the sign should be on the inactive leaf; if both leaves are active, the sign



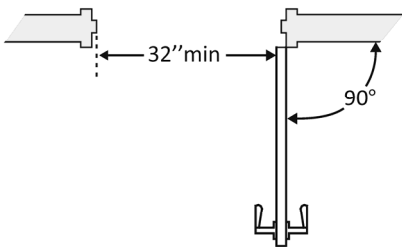
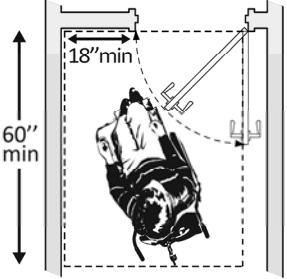
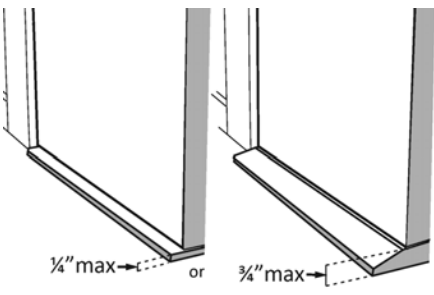
SEE PRIORITY 2 SECTION

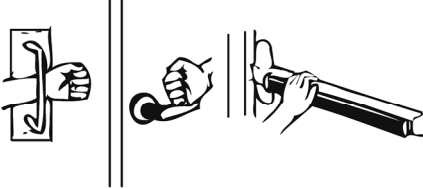
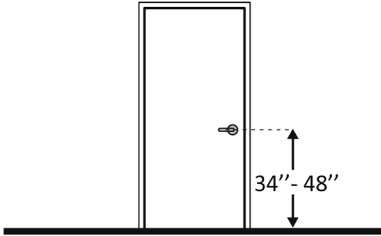

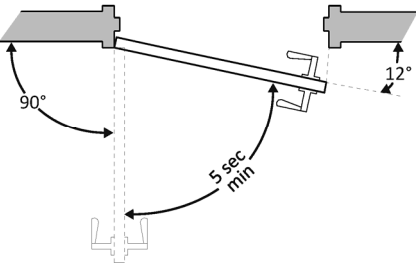
- Install tactile sign
- Relocate sign
-

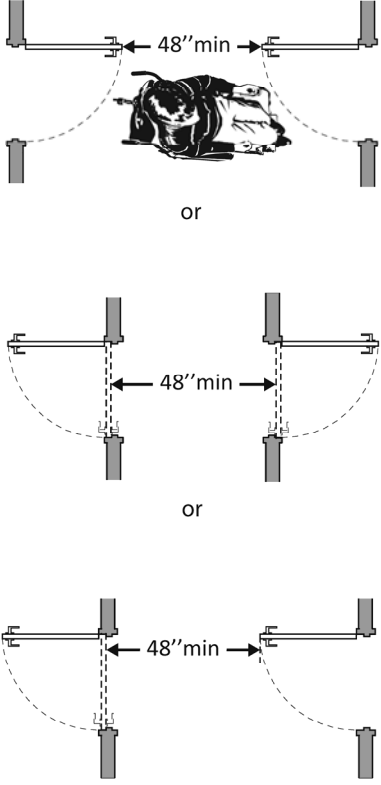
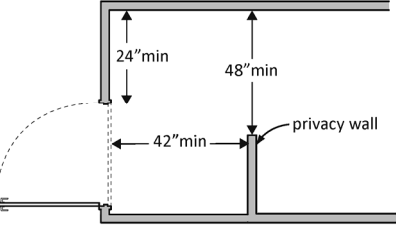


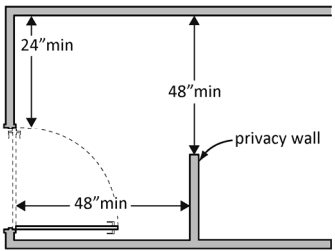

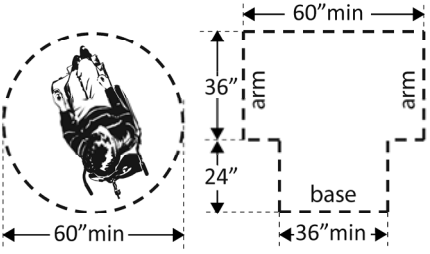
*If constructed before 3/15/2010 and a person may approach within 3 inches of the sign without encountering protruding objects or standing within the door swing, relocation not required

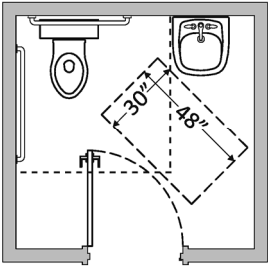
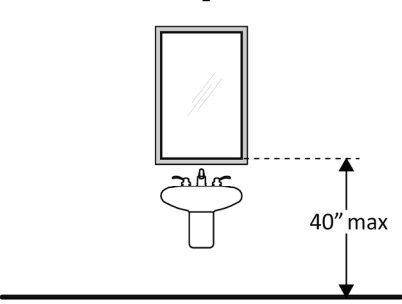
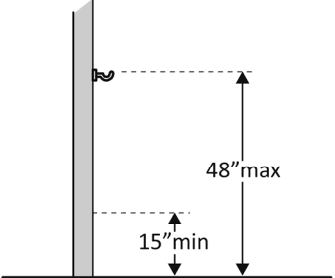
*If constructed before 3/15/2012 and mounted no higher than 60 inches to the centerline of the sign, relocation is not required

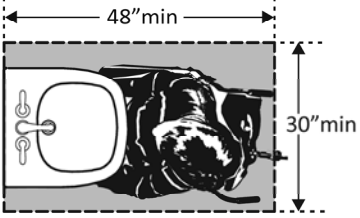
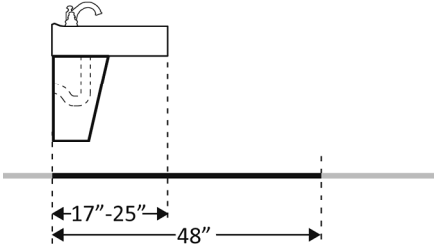
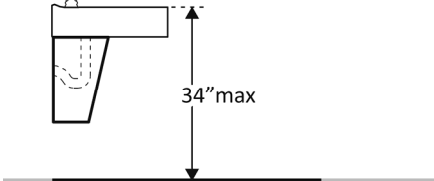
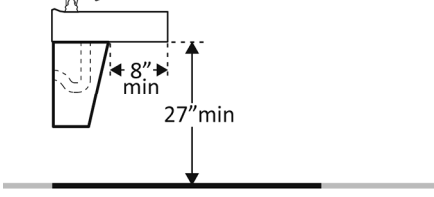
<p>should be on the wall to the right of the right leaf.</p>			<p>Photo #:</p>	
<p>Entrance (2010 Standards – 404)</p>				
<p>3.6 Is the door opening width at least 32 inches clear, between the face of the door and the stop, when the door is open 90 degrees?</p>	<p><input type="checkbox"/> Yes <input type="checkbox"/> No</p> <p>Measurement:</p>		<p>SEE PRIORITY 2 SECTION</p> <p>Photo #: 14</p>	<ul style="list-style-type: none"> • Install offset hinges • Alter the doorway •
<p>3.7 If there is a front approach to the pull side of the door is there at least 18 inches of maneuvering clearance beyond the latch side plus 60 inches clear depth?</p> <p>On both sides of the door, is the floor surface of the maneuvering clearance level (no steeper than 1:48)?</p>	<p><input type="checkbox"/> Yes <input type="checkbox"/> No</p> <p>Measurement:</p> <p><input type="checkbox"/> Yes <input type="checkbox"/> No</p> <p>Measurement:</p>		<p>SEE PRIORITY 2 SECTION</p> <p>Photo #:</p>	<ul style="list-style-type: none"> • Remove obstructions • Reconfigure walls • Add automatic door opener <p>See 2010 Standards 404.2.4 for maneuvering clearance requirements on the push side of the door and side approaches to the pull side of the door</p>
<p>3.8 Is the door threshold edge no more than ¼ inch high?</p> <p>Or</p> <p>No more than ¾ inch high if slope is beveled no steeper than 1:2?</p> <p>Note: The first ¼ inch of the threshold may be vertical; the rest must be beveled.</p>	<p><input type="checkbox"/> Yes <input type="checkbox"/> No</p> <p>Measurement:</p> <p><input type="checkbox"/> Yes <input type="checkbox"/> No</p> <p>Measurement:</p>		<p>SEE PRIORITY 2 SECTION</p> <p>Photo #:</p>	<ul style="list-style-type: none"> • Remove or replace threshold • •

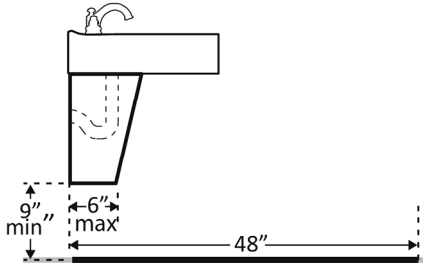
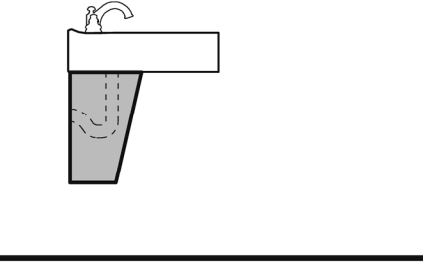
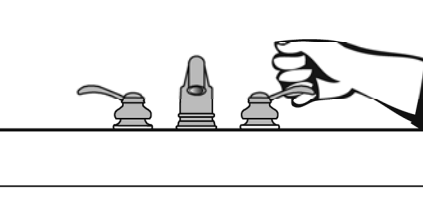
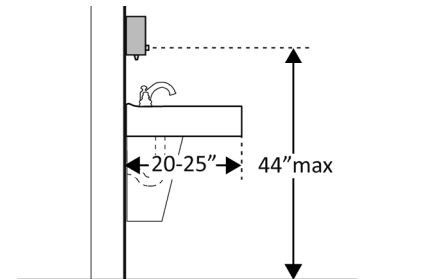
<p>3.9 Is the door equipped with hardware that is operable with one hand and does not require tight grasping, pinching, or twisting of the wrist? Check door handle and lock (if provided).</p>	<p><input type="checkbox"/> Yes <input type="checkbox"/> No</p> <p>Measurement:</p>		<p>SEE PRIORITY 2 SECTION</p> <p>Photo #:</p>	<ul style="list-style-type: none"> • Replace knobs or latches with lever or loop handles • Install power-assisted or automatic door openers •
<p>3.10 Are the operable parts of the door hardware mounted no less than 34 inches and no greater than 48 inches above the floor?</p>	<p><input type="checkbox"/> Yes <input type="checkbox"/> No</p> <p>Measurement:</p>		<p>SEE PRIORITY 2 SECTION</p> <p>Photo #:</p>	<ul style="list-style-type: none"> • Change hardware height • •
<p>3.11 Can the door be opened easily (5 pounds maximum force)?</p>	<p><input type="checkbox"/> Yes <input type="checkbox"/> No</p> <p>Measurement:</p>		<p>SEE PRIORITY 2 SECTION</p> <p>Photo #:</p>	<ul style="list-style-type: none"> • Adjust or replace closers • Install lighter doors • Install power-assisted or automatic door openers
<p>3.12 If the door has a closer, does it take at least 5 seconds to close from an open position of 90 degrees to a position of 12 degrees from the latch?</p>	<p><input type="checkbox"/> Yes <input type="checkbox"/> No</p> <p>Measurement:</p>		<p>SEE PRIORITY 2 SECTION</p> <p>Photo #:</p>	<ul style="list-style-type: none"> • Adjust closer • •

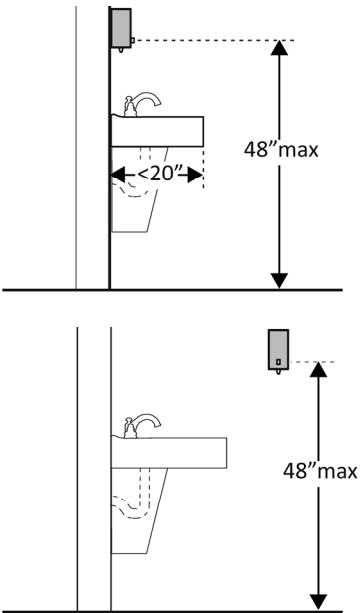
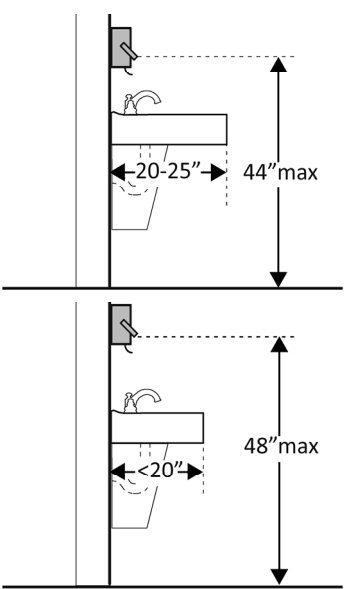
<p>3.13 If there are two doors in a series, e.g. vestibule, is the distance between the doors at least 48 inches plus the width of the doors when swinging into the space?</p>	<p><input type="checkbox"/> Yes <input type="checkbox"/> No</p> <p>Measurement:</p> <p>NA</p>	 <p>or</p> <p>or</p> <p>or</p>	<p>• 18 " required</p> <p>Photo #:</p>	<ul style="list-style-type: none"> • Remove inner door • Change door swing •
<p>3.14 If there is a privacy wall and the door swings out, is there at least 24 inches of maneuvering clearance beyond the door latch side and 42 inches to the privacy wall?</p>	<p><input type="checkbox"/> Yes <input type="checkbox"/> No</p> <p>Measurement:</p> <p>NA</p>	 <p>24" min</p> <p>48" min</p> <p>42" min</p> <p>privacy wall</p>	<p>• No Privacy Wall</p> <p>• 29" clearance behind to counter</p> <p>Photo #:</p>	<ul style="list-style-type: none"> • Reconfigure space • •

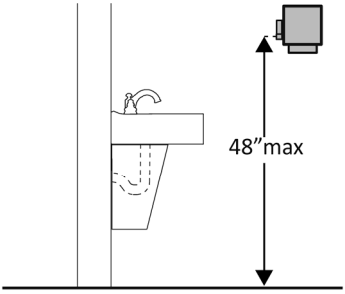
<p>3.15 If there is a privacy wall and the door swings in, is there at least 24 inches of maneuvering clearance beyond the door latch side and at least 48 inches to the privacy wall if there is no door closer or at least 54 inches if there is a door closer?</p>	<p><input type="checkbox"/> Yes <input type="checkbox"/> No</p> <p>Measurement:</p>		<p style="text-align: center; color: red; font-weight: bold;">NA</p> <p>Photo #:</p>	<ul style="list-style-type: none"> • Reconfigure space • •
In the Toilet Room				
<p>3.16 Is there a clear path to at least one of each type of fixture, e.g. lavatory, hand dryer, etc., that is at least 36 inches wide?</p>	<p><input checked="" type="checkbox"/> Yes <input type="checkbox"/> No</p> <p>Measurement:</p>		<p>Photo #:</p>	<ul style="list-style-type: none"> • Remove obstructions • •
<p>3.17 Is there clear floor space available for a person in a wheelchair to turn around, i.e. a circle at least 60 inches in diameter or a T-shaped space within a 60-inch square?*</p>	<p><input checked="" type="checkbox"/> Yes <input type="checkbox"/> No</p> <p>Measurement:</p>		<p>Photo #:</p>	<p>*The door to the toilet room may swing into the required turning space</p> <ul style="list-style-type: none"> • Move or remove partitions, fixtures or objects such as trash cans • •

<p>3.18 In a single user toilet room if the door swings in and over a clear floor space at an accessible fixture, is there a clear floor space at least 30 x 48 inches beyond the swing of the door?</p>	<p><input type="checkbox"/> Yes <input type="checkbox"/> No</p> <p>Measurement:</p>		<p style="text-align: center; color: red; font-weight: bold;">NA</p> <p>Photo #:</p>	<ul style="list-style-type: none"> • Reverse door swing • Alter toilet room •
<p>3.19 If the mirror is over a lavatory or countertop, is the bottom edge of the reflecting surface no higher than 40 inches above the floor? Or If the mirror is not over the lavatory or countertop, is the bottom edge of the reflecting surface no higher than 35 inches above the floor?*</p>	<p><input checked="" type="checkbox"/> Yes <input type="checkbox"/> No</p> <p>Measurement:</p> <p style="text-align: center; color: red; font-weight: bold;">37 ½"</p> <p><input type="checkbox"/> Yes <input type="checkbox"/> No</p> <p>Measurement:</p>		<p>Photo #: 15</p>	<p>* If installed before 3/15/2012 and the bottom edge of the reflecting surface is no higher than 40 inches above the floor, lowering the mirror to 35 inches is not required</p> <ul style="list-style-type: none"> • Lower the mirror • Add another mirror •
<p>3.20 If there is a coat hook, is it no less than 15 inches and no greater than 48 inches above the floor?</p>	<p><input type="checkbox"/> Yes <input type="checkbox"/> No</p> <p>Measurement:</p>		<p style="text-align: center; color: red; font-weight: bold;">NA</p> <p>Photo #:</p>	<ul style="list-style-type: none"> • Adjust hook • Replace with or provide additional accessible hook •

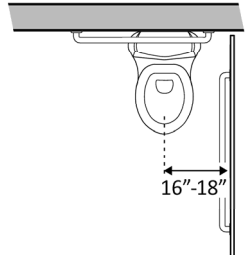
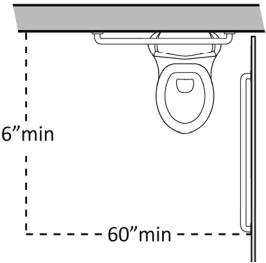
Lavatories (2010 Standards – 606) Note: 2010 Standards refer to sinks in toilet rooms as lavatories.				
<p>3.21 Does at least one lavatory have a clear floor space for a forward approach at least 30 inches wide and 48 inches long?</p>	<p><input checked="" type="checkbox"/> Yes <input type="checkbox"/> No</p> <p>Measurement:</p>		<p>Photo #: 15</p>	<ul style="list-style-type: none"> • Alter lavatory • Replace lavatory •
<p>3.22 Do no less than 17 inches and no greater than 25 inches of the clear floor space extend under the lavatory so that a person using a wheelchair can get close enough to reach the faucet?</p>	<p><input checked="" type="checkbox"/> Yes <input type="checkbox"/> No</p> <p>Measurement:</p>		<p>Photo #: 15</p>	<ul style="list-style-type: none"> • Alter lavatory • Replace lavatory •
<p>3.23 Is the front of the lavatory or counter surface, whichever is higher, no more than 34 inches above the floor?</p>	<p><input checked="" type="checkbox"/> Yes <input type="checkbox"/> No</p> <p>Measurement:</p>		<p>Photo #: 15</p>	<ul style="list-style-type: none"> • Alter lavatory • Replace lavatory •
<p>3.24 Is there at least 27 inches clearance from the floor to the bottom of the lavatory that extends at least 8 inches under the lav for knee clearance?</p>	<p><input type="checkbox"/> Yes <input checked="" type="checkbox"/> No</p> <p>Measurement:</p>		<p>Photo #: 15</p>	<ul style="list-style-type: none"> • Alter lavatory • Replace lavatory •

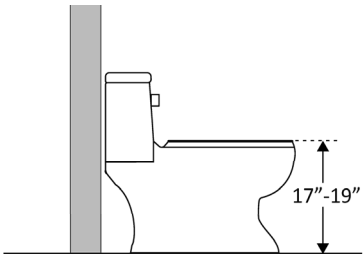
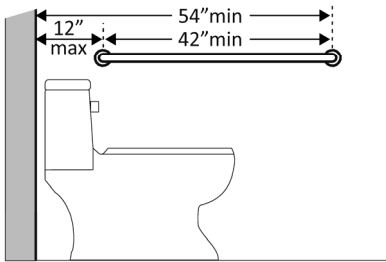
<p>3.25 Is there toe clearance at least 9 inches high? (Space extending greater than 6 inches beyond the available toe clearance at 9 inches above the floor is not considered toe clearance.)</p>	<p><input checked="" type="checkbox"/> Yes <input type="checkbox"/> No</p>		<p>Photo #: 15</p>	<ul style="list-style-type: none"> • Alter lavatory • Replace lavatory •
<p>3.26 Are pipes below the lavatory insulated or otherwise configured to protect against contact?</p>	<p><input checked="" type="checkbox"/> Yes <input type="checkbox"/> No</p>		<p>Photo #: 15</p>	<ul style="list-style-type: none"> • Install insulation • Install cover panel •
<p>3.27 Can the faucet be operated without tight grasping, pinching, or twisting of the wrist? Is the force required to activate the faucet no greater than 5 pounds?</p>	<p><input checked="" type="checkbox"/> Yes <input type="checkbox"/> No</p> <p><input type="checkbox"/> Yes <input type="checkbox"/> No</p>		<p>• SENSORS</p> <p>Photo #: 15</p>	<ul style="list-style-type: none"> • Adjust faucet • Replace faucet •
<p>Soap Dispensers and Hand Dryers (2010 Standards – 603)</p>				
<p>3.28 Are the operable parts of the soap dispenser within one of the following reach ranges: Above lavatories or counters no less than 20 inches and no greater than 25 inches deep: no higher than 44 inches above the floor?</p>	<p><input checked="" type="checkbox"/> Yes <input type="checkbox"/> No</p> <p>Measurement:</p>		<p>• 9" Above Counter</p> <p>• 42" Above Floor</p>	<ul style="list-style-type: none"> • Adjust dispensers • Replace with or provide additional accessible dispensers •

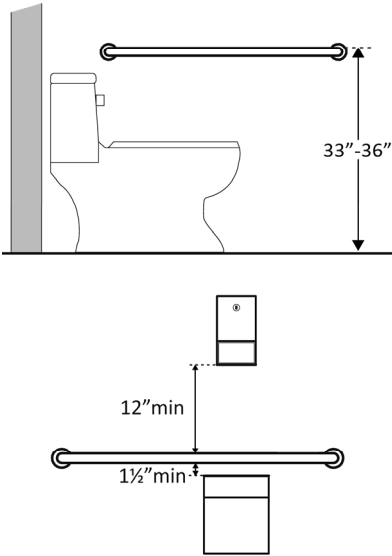
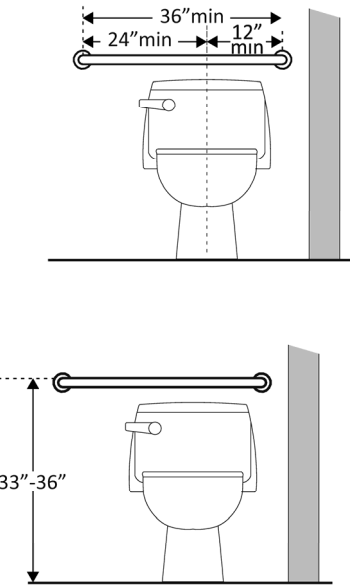
<p>Above lavatories less than 20 inches deep: no higher than 48 inches above the floor?</p> <p>Not over an obstruction: no higher than 48 inches above the floor?</p>	<p><input checked="" type="checkbox"/> Yes <input type="checkbox"/> No</p> <p>Measurement: 43"</p> <p><input type="checkbox"/> Yes <input type="checkbox"/> No</p> <p>Measurement:</p>		<p>Photo #: 15</p>	
<p>3.29 Are the operable parts of the hand dryer or towel dispenser within one of the following reach ranges:</p> <p>Above lavatories or counters no less than 20 inches and no greater than 25 inches deep: no higher than 44 inches above the floor?</p> <p>Above lavatories less than 20 inches deep: no higher than 48 inches above the floor?</p> <p>Not over an obstruction: no</p>	<p><input type="checkbox"/> Yes <input type="checkbox"/> No</p> <p>Measurement:</p> <p><input type="checkbox"/> Yes <input type="checkbox"/> No</p> <p>Measurement:</p> <p><input type="checkbox"/> Yes <input type="checkbox"/> No</p>		<p>NA</p>	<ul style="list-style-type: none"> • Adjust dispensers • Replace with or provide additional accessible dispensers •

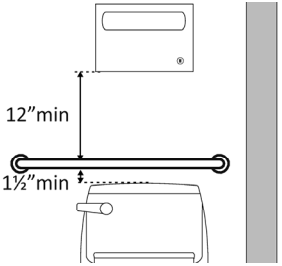
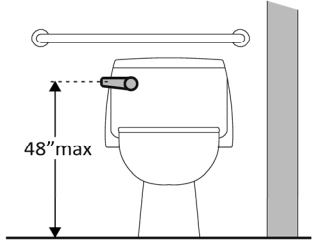
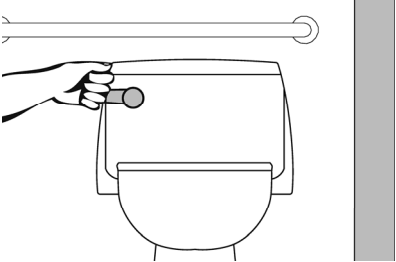
<p>higher than 48 inches above the floor?</p> <p>Can the operable parts of the hand dryer or towel dispenser be operated without tight grasping, pinching or twisting of the wrist?</p> <p>Is the force required to activate the hand dryer or towel dispenser no greater than 5 pounds?</p>	<p>Measurement:</p> <p><input type="checkbox"/> Yes <input type="checkbox"/> No</p> <p><input checked="" type="checkbox"/> Yes <input type="checkbox"/> No</p> <p>Measurement:</p>		<p>• 45"</p> <p>Photo #: 16</p>	
--	--	--	---------------------------------	--

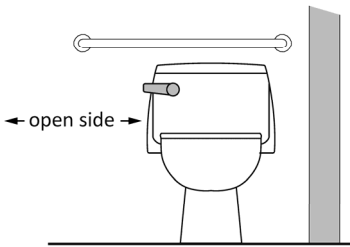
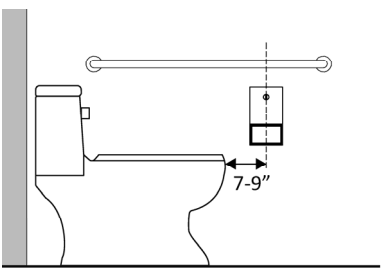
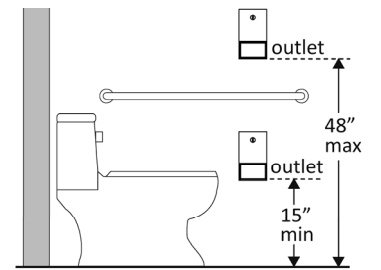
Water Closets in Single-User Toilet Rooms and Compartments (Stalls) (2010 Standards – 603 & 609) Note: 2010 Standards refer to toilets as water closets.

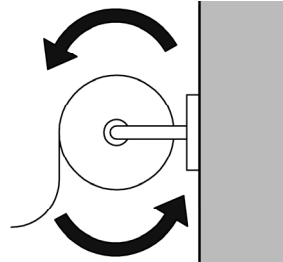
<p>3.30 Is the centerline of the water closet no less than 16 inches and no greater than 18 inches from the side wall or partition?</p>	<p><input checked="" type="checkbox"/> Yes <input type="checkbox"/> No</p> <p>Measurement:</p> <p>19"</p>		<p>Photo #: 18</p>	<ul style="list-style-type: none"> • Move toilet • Replace toilet • Move partition •
<p>3.31 Is clearance provided around the water closet measuring at least 60 inches from the side wall and at least 56 inches from the rear wall?*</p>	<p><input checked="" type="checkbox"/> Yes <input type="checkbox"/> No</p> <p>Measurement:</p>		<ul style="list-style-type: none"> • 60" from rear wall • 70" from side wall <p>Photo #: 19</p>	<p>* If constructed before 3/15/12, clearances around water closets in single user toilet rooms can be 48 inches wide by 66 inches long or 48 inches wide by 56 inches long (depending on the approach to the water closet, see 1991 Standards Figure 28) and the lavatory may overlap</p>

				<p>that clearance if the door to the room does not swing into the required clearances at fixtures (such as lavatories, water closet and urinals) and the edge of the lavatory is at least 18 inches from the centerline of the water closet</p> <ul style="list-style-type: none"> Alter room/compartment for clearance
<p>3.32 Is the height of the water closet no less than 17 inches and no greater than 19 inches above the floor measured to the top of the seat?</p>	<p><input checked="" type="checkbox"/> Yes <input type="checkbox"/> No</p> <p>Measurement:</p>		<ul style="list-style-type: none"> 17" height <p>Photo #: 17</p>	<ul style="list-style-type: none"> Adjust toilet height Replace toilet
<p>3.33 Is there a grab bar at least 42 inches long on the side wall?</p> <p>Is it located no more than 12 inches from the rear wall?</p> <p>Does it extend at least 54 inches from the rear wall?</p> <p>Is it mounted no less than 33</p>	<p><input checked="" type="checkbox"/> Yes <input type="checkbox"/> No</p> <p>Measurement:</p> <p><input checked="" type="checkbox"/> Yes <input type="checkbox"/> No</p> <p>Measurement:</p> <p><input type="checkbox"/> Yes <input checked="" type="checkbox"/> No</p> <p>Measurement:</p> <p><input checked="" type="checkbox"/> Yes <input type="checkbox"/> No</p>		<ul style="list-style-type: none"> 42 " grab bar 10 ½" from rear wall <ul style="list-style-type: none"> Center line 34" above finished floor 	<ul style="list-style-type: none"> Install grab bar Relocate grab bar Relocate objects

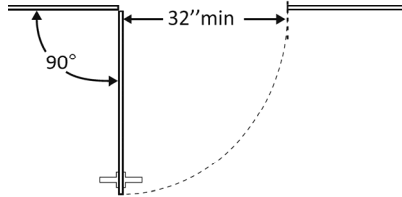
<p>inches and no greater than 36 inches above the floor to the top of the gripping surface?</p> <p>Is there at least 12 inches clearance between the grab bar and protruding objects above?*</p> <p>Is there at least 1½ inches clearance between the grab bar and projecting objects below?*</p> <p>Is the space between the wall and the grab bar 1 ½ inches?</p>	<p>Measurement:</p> <p><input checked="" type="checkbox"/> Yes <input type="checkbox"/> No</p> <p>Measurement:</p> <p><input type="checkbox"/> Yes <input checked="" type="checkbox"/> No</p> <p>Measurement:</p> <p><input checked="" type="checkbox"/> Yes <input type="checkbox"/> No</p> <p>Measurement:</p>		<p>• Mounted 34"</p> <p>Photo #: 19</p>	<p>* If constructed before 3/15/2012 grab bars do not need to be relocated; there are no space requirements above and below grab bars in the 1991 Standards</p>
<p>3.34 Is there a grab bar at least 36 inches long on the rear wall?</p> <p>Does it extend at least 12 inches from the centerline of the water closet on one side (side wall)?</p> <p>Does it extend at least 24 inches on the other (open) side?</p> <p>Is it mounted no less than 33 inches and no greater than 36 inches above the floor to the top of the gripping surface?</p>	<p><input checked="" type="checkbox"/> Yes <input type="checkbox"/> No</p> <p>Measurement:</p> <p><input checked="" type="checkbox"/> Yes <input type="checkbox"/> No</p> <p>Measurement:</p> <p><input checked="" type="checkbox"/> Yes <input type="checkbox"/> No</p> <p>Measurement:</p> <p><input type="checkbox"/> Yes <input type="checkbox"/> No</p> <p>Measurement:</p>		<p>• Grab Bar 36"</p> <p>Photo #: 19</p> <p>• Mounted 33 ½"</p> <p>Photo #: 19</p>	<ul style="list-style-type: none"> • Install grab bar • Relocate grab bar • Relocate objects •

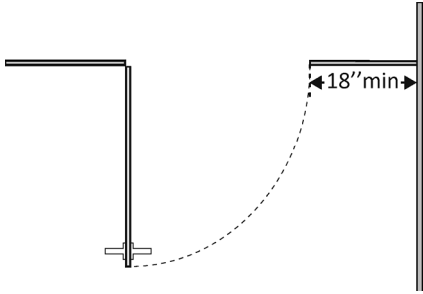
<p>Are there at least 12 inches clearance between the grab bar and protruding objects above?*</p> <p>Are there at least 1½ inches clearance between the grab bar and projecting objects below?*</p> <p>Is the space between the wall and the grab bar 1 ½ inches?</p>	<p><input checked="" type="checkbox"/> Yes <input type="checkbox"/> No Measurement:</p> <p><input checked="" type="checkbox"/> Yes <input type="checkbox"/> No Measurement:</p> <p><input checked="" type="checkbox"/> Yes <input type="checkbox"/> No Measurement:</p>		<p>Photo #: 19</p>	<p>* If constructed before 3/15/2012 grab bars do not need to be relocated; there are no space requirements above and below grab bars in the 1991 Standards</p>
<p>3.35 If the flush control is hand operated, is the operable part located no higher than 48 inches above the floor?</p>	<p><input type="checkbox"/> Yes <input type="checkbox"/> No Measurement:</p>		<p>NA AUTOMATIC FLUSH WALL MOUNT</p> <p>Photo #: 19</p>	<ul style="list-style-type: none"> • Move control • Install sensor with override button no higher than 48 inches •
<p>3.36 If the flush control is hand operated, can it be operated with one hand and without tight grasping, pinching, or twisting of the wrist?</p> <p>Is the force required to activate the flush control no greater than 5 pounds?</p>	<p><input type="checkbox"/> Yes <input type="checkbox"/> No Measurement:</p> <p><input type="checkbox"/> Yes <input type="checkbox"/> No Measurement:</p>		<p>NA</p> <p>Photo #:</p>	<ul style="list-style-type: none"> • Change control • Adjust control •

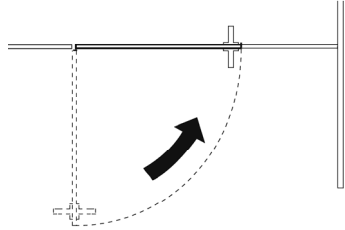
<p>3.37 Is the flush control on the open side of the water closet?</p>	<p><input type="checkbox"/> Yes <input type="checkbox"/> No</p>		<p style="text-align: center;">NA</p> <p>Photo #:</p>	<ul style="list-style-type: none"> • Move control • •
<p>3.38 Is the toilet paper dispenser located no less than 7 inches and no greater than 9 inches from the front of the water closet to the centerline of the dispenser?*</p>	<p><input type="checkbox"/> Yes <input checked="" type="checkbox"/> No</p> <p>Measurement:</p>		<p>Photo #: 19</p>	<p>* If constructed before 3/15/2012 dispenser does not need to be relocated if it is within reach from the water closet seat; the 1991 Standards do not specify distance from the front of the water closet</p> <ul style="list-style-type: none"> • Relocate dispenser • •
<p>3.39 Is the outlet of the dispenser:</p> <p>Located no less than 15 inches and no greater than 48 inches above the floor?</p> <p>Not located behind grab bars?</p>	<p><input checked="" type="checkbox"/> Yes <input type="checkbox"/> No</p> <p>Measurement:</p> <p><input type="checkbox"/> Yes <input checked="" type="checkbox"/> No</p>		<p>Photo #: 19</p>	<ul style="list-style-type: none"> • Relocate dispenser • •

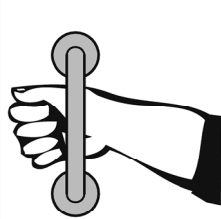
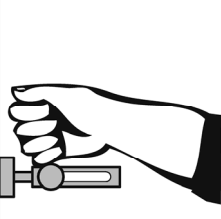
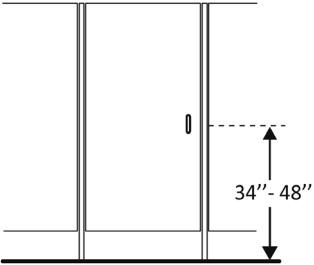
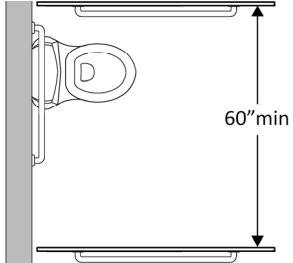
<p>3.40 Does the dispenser allow continuous paper flow?</p>	<p><input checked="" type="checkbox"/> Yes <input type="checkbox"/> No</p>		<p>Photo #: 19</p>	<ul style="list-style-type: none"> • Adjust dispenser • Replace dispenser •
--	--	---	---------------------------	--

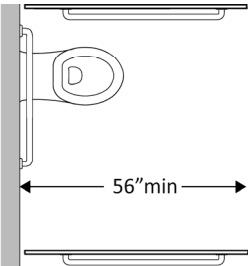
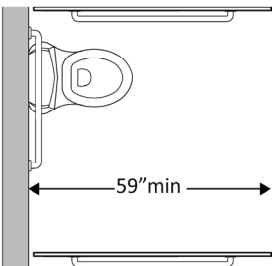
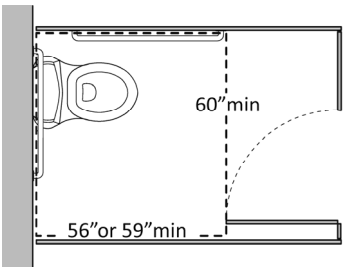
Toilet Compartments (Stalls) (2010 Standards – 604)

<p>3.41 Is the door opening width at least 32 inches clear, between the face of the door and the stop, when the door is open 90 degrees?</p>	<p><input checked="" type="checkbox"/> Yes <input type="checkbox"/> No</p> <p>Measurement:</p>		<p>Photo #: 20</p>	<ul style="list-style-type: none"> • Widen door width • •
---	--	--	---------------------------	--

<p>3.42 If there is a front approach to the pull side of the door, is there at least 18 inches of maneuvering clearance beyond the latch side plus 60 inches clear depth?*</p>	<p><input checked="" type="checkbox"/> Yes <input type="checkbox"/> No</p> <p>Measurement:</p>		<p>Photo #: 20</p>	<p>*See 2010 Standards 604.8.1.2 Doors for maneuvering clearance requirements on the push side of the door and side approaches to the pull side of the door</p> <ul style="list-style-type: none"> • Remove obstructions •
---	--	---	---------------------------	--

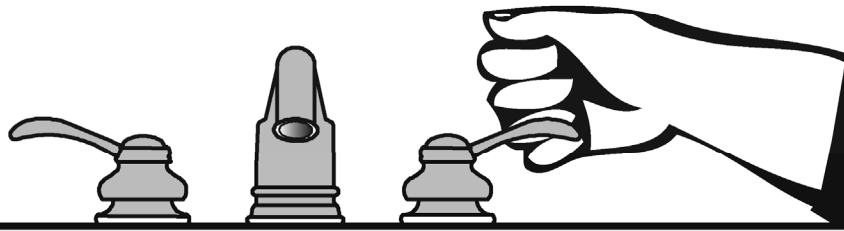
<p>3.43 Is the door self-closing?</p>	<p><input type="checkbox"/> Yes <input checked="" type="checkbox"/> No</p>		<p>Photo #: 20</p>	<ul style="list-style-type: none"> • Add closer • Replace door •
--	--	--	---------------------------	---

<p>3.44 Are there door pulls on both sides of the door that are operable with one hand and do not require tight grasping pinching or twisting of the wrist?*</p>	<p><input checked="" type="checkbox"/> Yes <input type="checkbox"/> No</p>		<p>Photo #: 20</p>	<p>* If constructed before 3/15/2012 door pulls do not need to be added; door pulls are not required in the 1991 Standards</p> <ul style="list-style-type: none"> • Replace hardware • •
<p>3.45 Is the lock operable with one hand and without tight grasping, pinching or twisting of the wrist?</p>	<p><input checked="" type="checkbox"/> Yes <input type="checkbox"/> No</p>		<p>Photo #: 20</p>	<ul style="list-style-type: none"> • Replace lock • •
<p>3.46 Are the operable parts of the door hardware mounted no less than 34 inches and no greater than 48 inches above the floor?</p>	<p><input checked="" type="checkbox"/> Yes <input type="checkbox"/> No</p> <p>Measurement:</p> <p>41 1/2"</p>		<p>Photo #: 20</p>	<ul style="list-style-type: none"> • Relocate hardware • •
<p>3.47 Is the compartment at least 60 inches wide?</p>	<p><input checked="" type="checkbox"/> Yes <input type="checkbox"/> No</p> <p>Measurement:</p>		<p>Photo #:</p>	<ul style="list-style-type: none"> • Widen compartment • •

<p>3.48 If the water closet is wall hung, is the compartment at least 56 inches deep?</p>	<p><input type="checkbox"/> Yes <input type="checkbox"/> No</p> <p>Measurement:</p>		<p>SEE PRIORITY 2 SECTION</p> <p>Photo #:</p>	<ul style="list-style-type: none"> • Widen compartment • •
<p>3.49 If the water closet is floor mounted, is the compartment at least 59 inches deep?</p>	<p><input type="checkbox"/> Yes <input type="checkbox"/> No</p> <p>Measurement:</p>		<p>SEE PRIORITY 2 SECTION</p> <p>Photo #:</p>	<ul style="list-style-type: none"> • Alter compartment • •
<p>3.50 If the door swings in, is the minimum required compartment area provided beyond the swing of the door (60 inches x 56 inches if water closet is wall hung or 59 inches if water closet is floor mounted)?</p>	<p><input type="checkbox"/> Yes <input type="checkbox"/> No</p> <p>Measurement:</p>		<p>SEE PRIORITY 2 SECTION</p> <p>Photo #:</p>	<ul style="list-style-type: none"> • Reverse door swing • Alter compartment •
	<p><input type="checkbox"/> Yes <input type="checkbox"/> No</p>		<p>Photo #:</p>	<ul style="list-style-type: none"> • • •
	<p><input type="checkbox"/> Yes <input type="checkbox"/> No</p>		<p>Photo #:</p>	<ul style="list-style-type: none"> • • •

The ADA Checklist for Readily Achievable Barrier Removal

Priority 3 – Women’s Toilet Rooms



Project **SDDOT Rest Area Improvements**
FHU Reference Number 13-039-01
TSP Project Number 03120855

Building **TILFORD EAST**

Location **90 E., MRM 41**

Date **09-19-2013 (Inspection)**

Surveyors **Timothy Roach, AIA**
Todd Schultz, PE

Contact Information **TSP – (605) 343-6102**



When toilet rooms are open to the public they should be accessible to people with disabilities.



Institute for Human Centered Design
www.HumanCenteredDesign.org
November 2011



ADA National Network
Questions on the ADA 800-949-4232 voice/tty
www.ADAchecklist.org

Priority 3 – Toilet Rooms		Comments	Possible Solutions
<p>3.1 If toilet rooms are available to the public, is at least one toilet room accessible? (Either one for each sex, or one unisex.)</p>	<input checked="" type="checkbox"/> Yes <input type="checkbox"/> No	<p>Photo #: 21</p>	<ul style="list-style-type: none"> • Reconfigure toilet rooms • Combine toilet rooms to create one unisex accessible toilet room •
<p>3.2 Are there signs at inaccessible toilet rooms that give directions to accessible toilet rooms?</p>	<input type="checkbox"/> Yes <input type="checkbox"/> No	 <p>Photo #:</p>	<ul style="list-style-type: none"> • Install signs • •
<p>3.3 If not all toilet rooms are accessible, is there a sign at the accessible toilet room with the International Symbol of Accessibility?</p>	<input type="checkbox"/> Yes <input type="checkbox"/> No	 <p>Photo #:</p>	<ul style="list-style-type: none"> • Install sign • •
<p>Accessible Route (2010 Standards – Chapter 4)</p>			
<p>3.4 Is there a route to the accessible toilet room(s) that does not include the use of stairs?</p> <p>Is the route accessible? (See Priority 2 Interior Accessible Route for specifics.)</p>	<input checked="" type="checkbox"/> Yes <input type="checkbox"/> No <input type="checkbox"/> Yes <input checked="" type="checkbox"/> No	<ul style="list-style-type: none"> • Insufficient clearance @ door <p>Photo #: 21</p>	<ul style="list-style-type: none"> • Alter route • •

Signs at Toilet Rooms (2010 Standards – 703)

3.5 Do text characters contrast with their backgrounds?

Yes No

Are text characters raised?

Yes No

Is there Braille?

Yes No

Is the sign mounted:
On the wall on the latch side of the door?

Yes No

Note:

Signs are permitted on the push side of doors with closers and without hold-open devices.

With clear floor space beyond the arc of the door swing and 45-degree open position, at least 18 x 18 inches centered on the tactile characters? *

Yes No

Measurement:

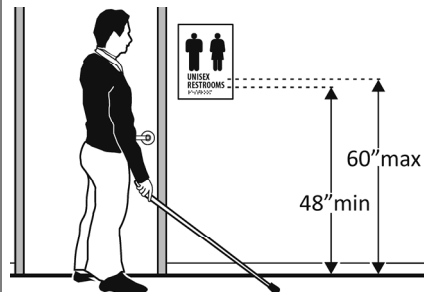
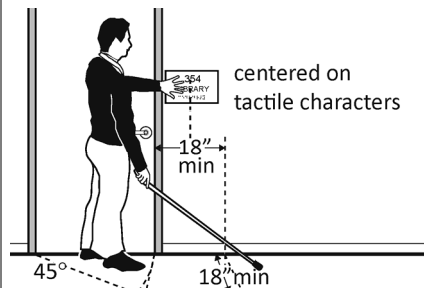
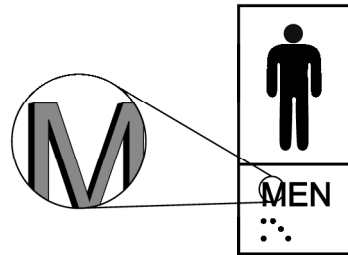
So the baseline of the lowest character is at least 48 inches above the floor and the baseline of the highest character is no more than 60 inches above the floor? *

Yes No

Measurement:

Note:

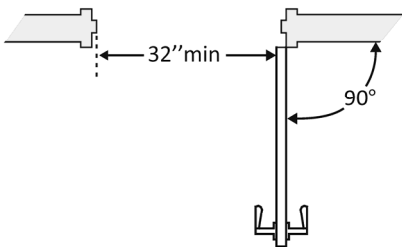
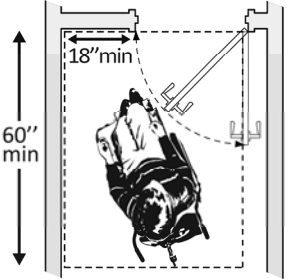
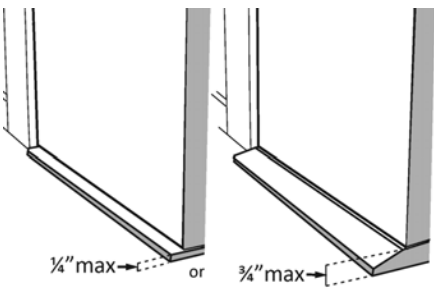
If the sign is at double doors with one active leaf, the sign should be on the inactive leaf; if both leaves are active, the sign

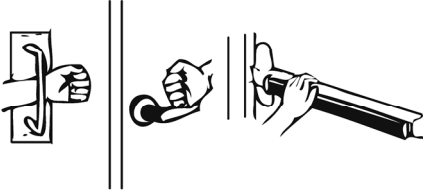
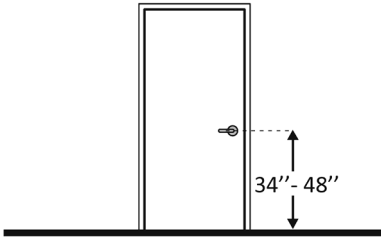

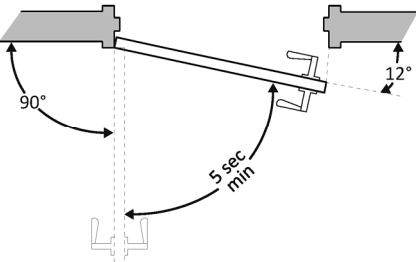


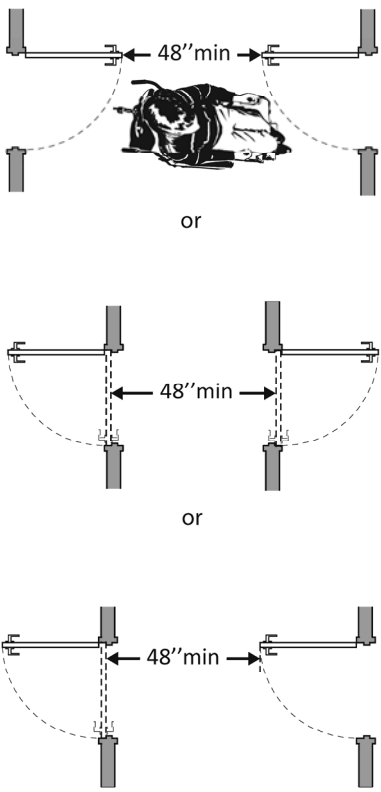
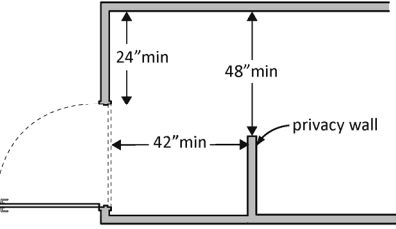
- Install tactile sign
- Relocate sign
-

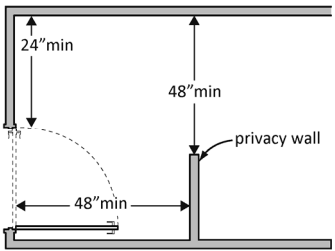

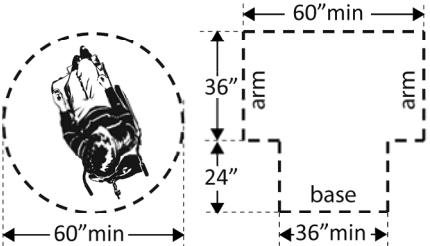
*If constructed before 3/15/2010 and a person may approach within 3 inches of the sign without encountering protruding objects or standing within the door swing, relocation not required

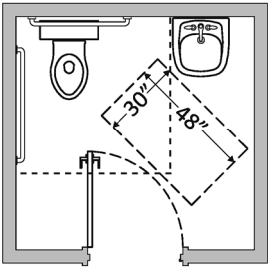
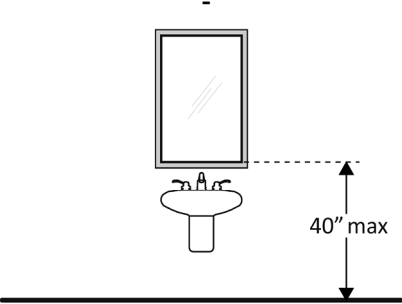
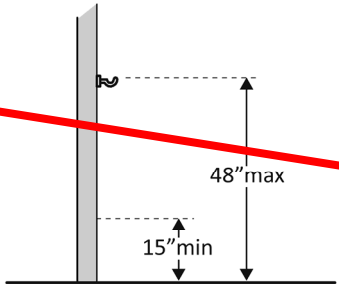
*If constructed before 3/15/2012 and mounted no higher than 60 inches to the centerline of the sign, relocation is not required

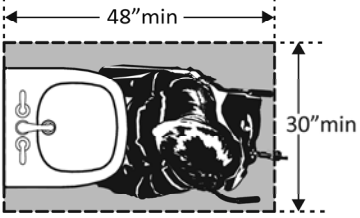
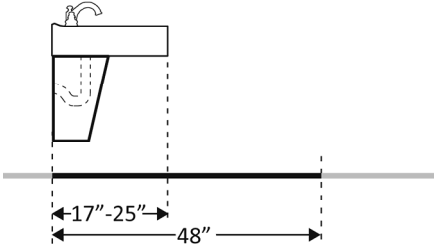
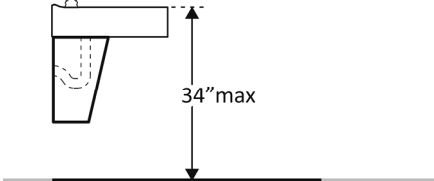
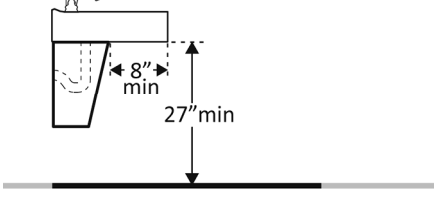
<p>should be on the wall to the right of the right leaf.</p>			<p>Photo #: 22</p>	
<p>Entrance (2010 Standards – 404)</p>				
<p>3.6 Is the door opening width at least 32 inches clear, between the face of the door and the stop, when the door is open 90 degrees?</p>	<p><input checked="" type="checkbox"/> Yes <input type="checkbox"/> No</p> <p>Measurement:</p>		<p>Photo #:</p>	<ul style="list-style-type: none"> • Install offset hinges • Alter the doorway •
<p>3.7 If there is a front approach to the pull side of the door is there at least 18 inches of maneuvering clearance beyond the latch side plus 60 inches clear depth?</p> <p>On both sides of the door, is the floor surface of the maneuvering clearance level (no steeper than 1:48)?</p>	<p><input type="checkbox"/> Yes <input type="checkbox"/> No</p> <p>Measurement:</p> <p><input type="checkbox"/> Yes <input type="checkbox"/> No</p> <p>Measurement:</p>		<p>Photo #: 23</p>	<ul style="list-style-type: none"> • Remove obstructions • Reconfigure walls • Add automatic door opener <p>See 2010 Standards 404.2.4 for maneuvering clearance requirements on the push side of the door and side approaches to the pull side of the door</p>
<p>3.8 Is the door threshold edge no more than ¼ inch high?</p> <p>Or</p> <p>No more than ¾ inch high if slope is beveled no steeper than 1:2?</p> <p>Note: The first ¼ inch of the threshold may be vertical; the rest must be beveled.</p>	<p><input checked="" type="checkbox"/> Yes <input type="checkbox"/> No</p> <p>Measurement:</p> <p><input type="checkbox"/> Yes <input type="checkbox"/> No</p> <p>Measurement:</p>		<p>Photo #: 21</p>	<ul style="list-style-type: none"> • Remove or replace threshold • •

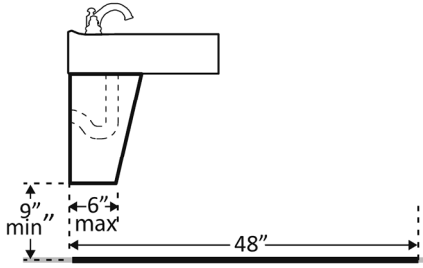
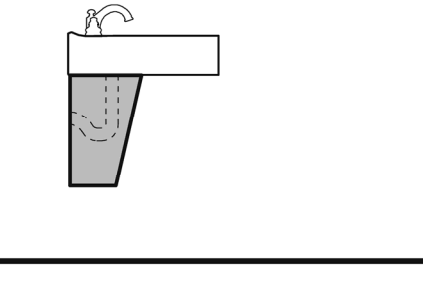
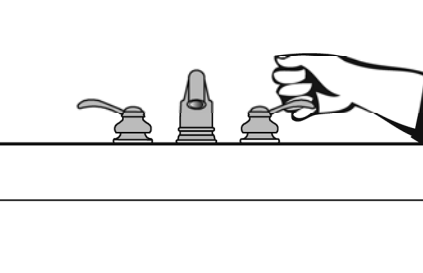
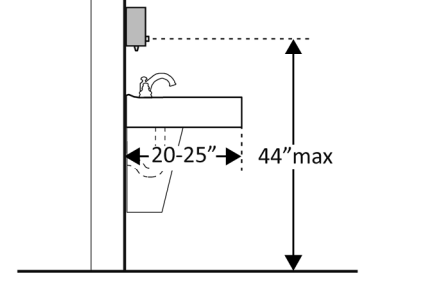
<p>3.9 Is the door equipped with hardware that is operable with one hand and does not require tight grasping, pinching, or twisting of the wrist? Check door handle and lock (if provided).</p>	<p><input type="checkbox"/> Yes <input checked="" type="checkbox"/> No</p> <p>Measurement:</p>		<p>Photo #: 23</p>	<ul style="list-style-type: none"> • Replace knobs or latches with lever or loop handles • Install power-assisted or automatic door openers •
<p>3.10 Are the operable parts of the door hardware mounted no less than 34 inches and no greater than 48 inches above the floor?</p>	<p><input checked="" type="checkbox"/> Yes <input type="checkbox"/> No</p> <p>Measurement:</p>		<p>Photo #: 23</p>	<ul style="list-style-type: none"> • Change hardware height • •
<p>3.11 Can the door be opened easily (5 pounds maximum force)?</p>	<p><input type="checkbox"/> Yes <input type="checkbox"/> No</p> <p>Measurement:</p>		<p>SEE PRIORITY 2 SECTION</p> <p>Photo #:</p>	<ul style="list-style-type: none"> • Adjust or replace closers • Install lighter doors • Install power-assisted or automatic door openers
<p>3.12 If the door has a closer, does it take at least 5 seconds to close from an open position of 90 degrees to a position of 12 degrees from the latch?</p>	<p><input type="checkbox"/> Yes <input type="checkbox"/> No</p> <p>Measurement:</p>		<p>SEE PRIORITY 2 SECTION</p> <p>Photo #:</p>	<ul style="list-style-type: none"> • Adjust closer • •

<p>3.13 If there are two doors in a series, e.g. vestibule, is the distance between the doors at least 48 inches plus the width of the doors when swinging into the space?</p>	<p><input type="checkbox"/> Yes <input checked="" type="checkbox"/> No</p> <p>Measurement:</p>	 <p>48" min</p> <p>or</p> <p>48" min</p> <p>or</p> <p>48" min</p>	<p>Photo #:</p>	<ul style="list-style-type: none"> • Remove inner door • Change door swing •
<p>3.14 If there is a privacy wall and the door swings out, is there at least 24 inches of maneuvering clearance beyond the door latch side and 42 inches to the privacy wall?</p>	<p><input type="checkbox"/> Yes <input checked="" type="checkbox"/> No</p> <p>Measurement:</p>	 <p>24" min</p> <p>48" min</p> <p>42" min</p> <p>privacy wall</p>	<p>Photo #: 24</p>	<ul style="list-style-type: none"> • Reconfigure space • •

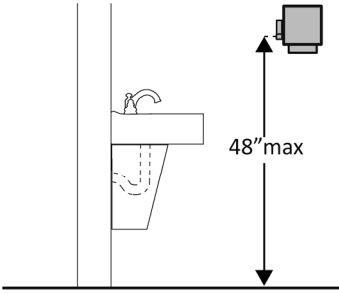
<p>3.15 If there is a privacy wall and the door swings in, is there at least 24 inches of maneuvering clearance beyond the door latch side and at least 48 inches to the privacy wall if there is no door closer or at least 54 inches if there is a door closer?</p>	<p><input type="checkbox"/> Yes <input type="checkbox"/> No</p> <p>Measurement:</p>		<p style="text-align: center; color: red; font-weight: bold;">NA</p> <p>Photo #:</p>	<ul style="list-style-type: none"> • Reconfigure space • •
<p>In the Toilet Room</p>				
<p>3.16 Is there a clear path to at least one of each type of fixture, e.g. lavatory, hand dryer, etc., that is at least 36 inches wide?</p>	<p><input checked="" type="checkbox"/> Yes <input type="checkbox"/> No</p> <p>Measurement:</p>		<p>Photo #: 25</p>	<ul style="list-style-type: none"> • Remove obstructions • •
<p>3.17 Is there clear floor space available for a person in a wheelchair to turn around, i.e. a circle at least 60 inches in diameter or a T-shaped space within a 60-inch square?*</p>	<p><input checked="" type="checkbox"/> Yes <input type="checkbox"/> No</p> <p>Measurement:</p>		<p>Photo #: 26</p>	<p>*The door to the toilet room may swing into the required turning space</p> <ul style="list-style-type: none"> • Move or remove partitions, fixtures or objects such as trash cans • •

<p>3.18 In a single user toilet room if the door swings in and over a clear floor space at an accessible fixture, is there a clear floor space at least 30 x 48 inches beyond the swing of the door?</p>	<p><input type="checkbox"/> Yes <input type="checkbox"/> No</p> <p>Measurement:</p>		<p style="text-align: center; color: red; font-weight: bold;">NA</p> <p>Photo #:</p>	<ul style="list-style-type: none"> • Reverse door swing • Alter toilet room •
<p>3.19 If the mirror is over a lavatory or countertop, is the bottom edge of the reflecting surface no higher than 40 inches above the floor? Or If the mirror is not over the lavatory or countertop, is the bottom edge of the reflecting surface no higher than 35 inches above the floor?*</p>	<p><input checked="" type="checkbox"/> Yes <input type="checkbox"/> No</p> <p>Measurement:</p> <p style="text-align: center; color: red; font-weight: bold;">37 ½"</p> <p><input type="checkbox"/> Yes <input type="checkbox"/> No</p> <p>Measurement:</p>		<p>Photo #: 26</p>	<p>* If installed before 3/15/2012 and the bottom edge of the reflecting surface is no higher than 40 inches above the floor, lowering the mirror to 35 inches is not required</p> <ul style="list-style-type: none"> • Lower the mirror • Add another mirror •
<p>3.20 If there is a coat hook, is it no less than 15 inches and no greater than 48 inches above the floor?</p>	<p><input type="checkbox"/> Yes <input type="checkbox"/> No</p> <p>Measurement:</p>		<p>Photo #:</p>	<ul style="list-style-type: none"> • Adjust hook • Replace with or provide additional accessible hook •

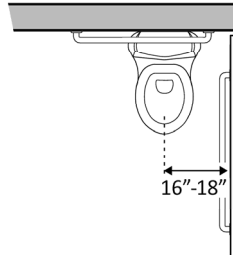
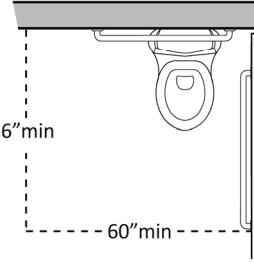
Lavatories (2010 Standards – 606) Note: 2010 Standards refer to sinks in toilet rooms as lavatories.				
<p>3.21 Does at least one lavatory have a clear floor space for a forward approach at least 30 inches wide and 48 inches long?</p>	<p><input checked="" type="checkbox"/> Yes <input type="checkbox"/> No</p> <p>Measurement:</p>		<p>Photo #: 26</p>	<ul style="list-style-type: none"> • Alter lavatory • Replace lavatory •
<p>3.22 Do no less than 17 inches and no greater than 25 inches of the clear floor space extend under the lavatory so that a person using a wheelchair can get close enough to reach the faucet?</p>	<p><input checked="" type="checkbox"/> Yes <input type="checkbox"/> No</p> <p>Measurement:</p>		<p>Photo #: 26</p>	<ul style="list-style-type: none"> • Alter lavatory • Replace lavatory •
<p>3.23 Is the front of the lavatory or counter surface, whichever is higher, no more than 34 inches above the floor?</p>	<p><input checked="" type="checkbox"/> Yes <input type="checkbox"/> No</p> <p>Measurement:</p>		<p>Photo #: 26</p>	<ul style="list-style-type: none"> • Alter lavatory • Replace lavatory •
<p>3.24 Is there at least 27 inches clearance from the floor to the bottom of the lavatory that extends at least 8 inches under the lav for knee clearance?</p>	<p><input type="checkbox"/> Yes <input checked="" type="checkbox"/> No</p> <p>Measurement:</p>		<p>Photo #: 26</p>	<ul style="list-style-type: none"> • Alter lavatory • Replace lavatory •

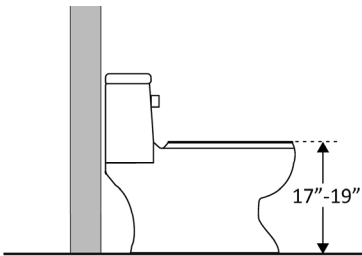
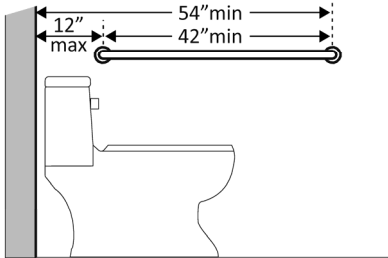
<p>3.25 Is there toe clearance at least 9 inches high? (Space extending greater than 6 inches beyond the available toe clearance at 9 inches above the floor is not considered toe clearance.)</p>	<p><input checked="" type="checkbox"/> Yes <input type="checkbox"/> No</p>		<p>Photo #: 26</p>	<ul style="list-style-type: none"> • Alter lavatory • Replace lavatory •
<p>3.26 Are pipes below the lavatory insulated or otherwise configured to protect against contact?</p>	<p><input checked="" type="checkbox"/> Yes <input type="checkbox"/> No</p>		<p>Photo #: 26</p>	<ul style="list-style-type: none"> • Install insulation • Install cover panel •
<p>3.27 Can the faucet be operated without tight grasping, pinching, or twisting of the wrist? Is the force required to activate the faucet no greater than 5 pounds?</p>	<p><input checked="" type="checkbox"/> Yes <input type="checkbox"/> No <input type="checkbox"/> Yes <input type="checkbox"/> No</p>		<p>• Sensors</p> <p>Photo #: 26</p>	<ul style="list-style-type: none"> • Adjust faucet • Replace faucet •
<p>Soap Dispensers and Hand Dryers (2010 Standards – 603)</p>				
<p>3.28 Are the operable parts of the soap dispenser within one of the following reach ranges: Above lavatories or counters no less than 20 inches and no greater than 25 inches deep: no higher than 44 inches above the floor?</p>	<p><input checked="" type="checkbox"/> Yes <input type="checkbox"/> No Measurement:</p>		<ul style="list-style-type: none"> • 9" Above Counter • 42" Above Floor 	<ul style="list-style-type: none"> • Adjust dispensers • Replace with or provide additional accessible dispensers •

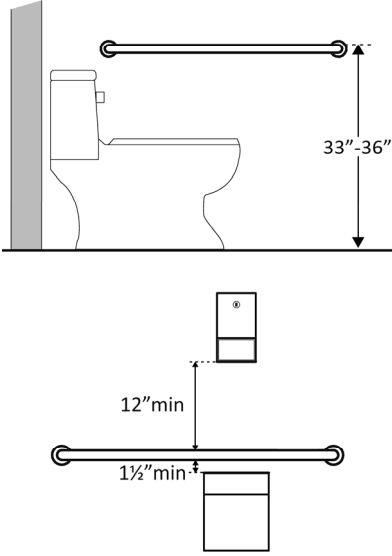
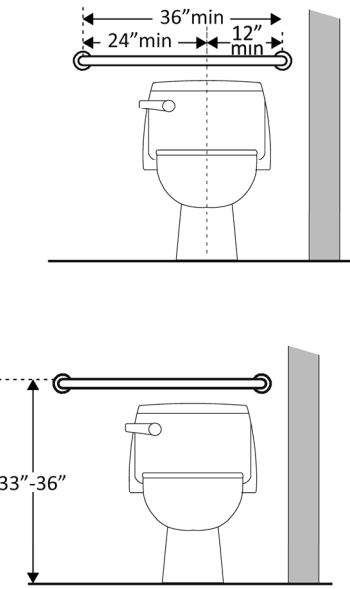
<p>Above lavatories less than 20 inches deep: no higher than 48 inches above the floor?</p> <p>Not over an obstruction: no higher than 48 inches above the floor?</p>	<p><input checked="" type="checkbox"/> Yes <input type="checkbox"/> No</p> <p>Measurement: 43"</p> <p><input type="checkbox"/> Yes <input type="checkbox"/> No</p> <p>Measurement:</p>		<p>Photo #: 26</p>	
<p>3.29 Are the operable parts of the hand dryer or towel dispenser within one of the following reach ranges:</p> <p>Above lavatories or counters no less than 20 inches and no greater than 25 inches deep: no higher than 44 inches above the floor?</p> <p>Above lavatories less than 20 inches deep: no higher than 48 inches above the floor?</p> <p>Not over an obstruction: no</p>	<p><input type="checkbox"/> Yes <input type="checkbox"/> No</p> <p>Measurement:</p> <p><input type="checkbox"/> Yes <input type="checkbox"/> No</p> <p>Measurement:</p> <p><input type="checkbox"/> Yes <input type="checkbox"/> No</p>		<p>NA</p>	<ul style="list-style-type: none"> • Adjust dispensers • Replace with or provide additional accessible dispensers •

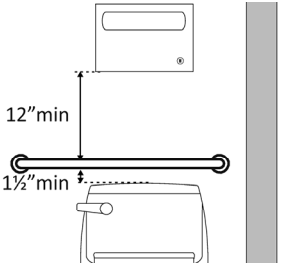
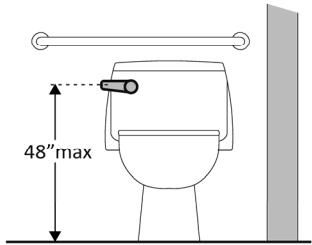
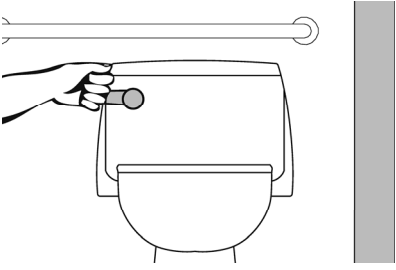
<p>higher than 48 inches above the floor?</p> <p>Can the operable parts of the hand dryer or towel dispenser be operated without tight grasping, pinching or twisting of the wrist?</p> <p>Is the force required to activate the hand dryer or towel dispenser no greater than 5 pounds?</p>	<p>Measurement:</p> <p><input checked="" type="checkbox"/> Yes <input type="checkbox"/> No</p> <p><input type="checkbox"/> Yes <input checked="" type="checkbox"/> No</p> <p>Measurement:</p>		<p>• 42"</p> <p>Photo #:</p>	
--	---	--	------------------------------	--

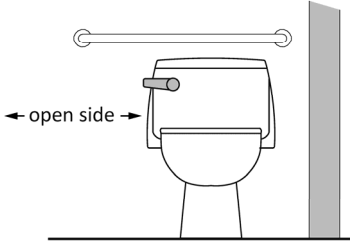
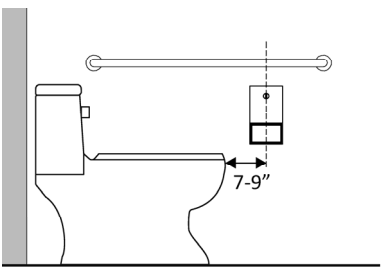
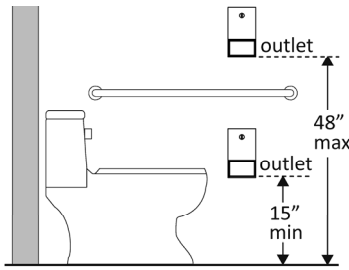
Water Closets in Single-User Toilet Rooms and Compartments (Stalls) (2010 Standards – 603 & 609) Note: 2010 Standards refer to toilets as water closets.

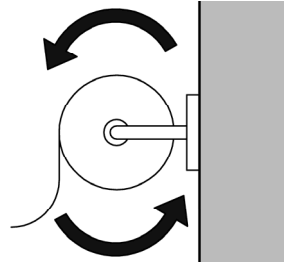
<p>3.30 Is the centerline of the water closet no less than 16 inches and no greater than 18 inches from the side wall or partition?</p>	<p><input checked="" type="checkbox"/> Yes <input type="checkbox"/> No</p> <p>Measurement:</p> <p>18"</p>		<p>Photo #:</p>	<ul style="list-style-type: none"> • Move toilet • Replace toilet • Move partition •
<p>3.31 Is clearance provided around the water closet measuring at least 60 inches from the side wall and at least 56 inches from the rear wall?*</p>	<p><input checked="" type="checkbox"/> Yes <input type="checkbox"/> No</p> <p>Measurement:</p>		<p>• 60" from rear wall</p> <p>• 70" from side wall</p> <p>Photo #: 26</p>	<p>* If constructed before 3/15/12, clearances around water closets in single user toilet rooms can be 48 inches wide by 66 inches long or 48 inches wide by 56 inches long (depending on the approach to the water closet, see 1991 Standards Figure 28) and the lavatory may overlap</p>

			<p>Photo #:</p>	<p>that clearance if the door to the room does not swing into the required clearances at fixtures (such as lavatories, water closet and urinals) and the edge of the lavatory is at least 18 inches from the centerline of the water closet</p> <ul style="list-style-type: none"> Alter room/compartment for clearance
<p>3.32 Is the height of the water closet no less than 17 inches and no greater than 19 inches above the floor measured to the top of the seat?</p>	<p><input checked="" type="checkbox"/> Yes <input type="checkbox"/> No</p> <p>Measurement:</p>		<p>• Height 17"</p> <p>Photo #: 28</p>	<ul style="list-style-type: none"> Adjust toilet height Replace toilet
<p>3.33 Is there a grab bar at least 42 inches long on the side wall?</p> <p>Is it located no more than 12 inches from the rear wall?</p> <p>Does it extend at least 54 inches from the rear wall?</p> <p>Is it mounted no less than 33</p>	<p><input checked="" type="checkbox"/> Yes <input type="checkbox"/> No</p> <p>Measurement:</p> <p><input checked="" type="checkbox"/> Yes <input type="checkbox"/> No</p> <p>Measurement:</p> <p><input type="checkbox"/> Yes <input checked="" type="checkbox"/> No</p> <p>Measurement:</p> <p><input checked="" type="checkbox"/> Yes <input type="checkbox"/> No</p>		<p>• 42 " grab bar</p> <p>• 10 ½" from rear wall</p> <p>• Center line 34" above finished floor</p>	<ul style="list-style-type: none"> Install grab bar Relocate grab bar Relocate objects

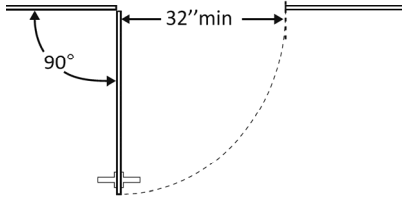
<p>inches and no greater than 36 inches above the floor to the top of the gripping surface?</p> <p>Is there at least 12 inches clearance between the grab bar and protruding objects above?*</p> <p>Is there at least 1½ inches clearance between the grab bar and projecting objects below?*</p> <p>Is the space between the wall and the grab bar 1 ½ inches?</p>	<p>Measurement:</p> <p><input checked="" type="checkbox"/> Yes <input type="checkbox"/> No</p> <p>Measurement:</p> <p><input type="checkbox"/> Yes <input checked="" type="checkbox"/> No</p> <p>Measurement:</p> <p><input checked="" type="checkbox"/> Yes <input type="checkbox"/> No</p> <p>Measurement:</p>		<p>• Mounted 34"</p> <p>Photo #: 29</p>	<p>* If constructed before 3/15/2012 grab bars do not need to be relocated; there are no space requirements above and below grab bars in the 1991 Standards</p>
<p>3.34 Is there a grab bar at least 36 inches long on the rear wall?</p> <p>Does it extend at least 12 inches from the centerline of the water closet on one side (side wall)?</p> <p>Does it extend at least 24 inches on the other (open) side?</p> <p>Is it mounted no less than 33 inches and no greater than 36 inches above the floor to the top of the gripping surface?</p>	<p><input checked="" type="checkbox"/> Yes <input type="checkbox"/> No</p> <p>Measurement:</p> <p><input checked="" type="checkbox"/> Yes <input type="checkbox"/> No</p> <p>Measurement:</p> <p><input checked="" type="checkbox"/> Yes <input type="checkbox"/> No</p> <p>Measurement:</p>		<p>• Grab Bar 36"</p> <p>Photo #:</p> <p>• Mounted 33 ½"</p> <p>Photo #: 29</p>	<ul style="list-style-type: none"> • Install grab bar • Relocate grab bar • Relocate objects •

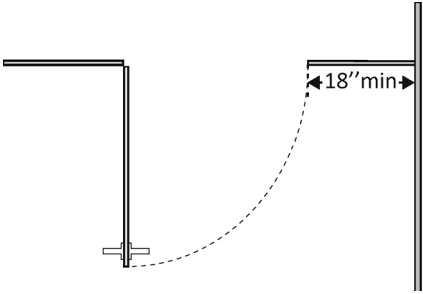
<p>Are there at least 12 inches clearance between the grab bar and protruding objects above?*</p> <p>Are there at least 1½ inches clearance between the grab bar and projecting objects below?*</p> <p>Is the space between the wall and the grab bar 1 ½ inches?</p>	<p><input checked="" type="checkbox"/> Yes <input type="checkbox"/> No Measurement:</p> <p><input checked="" type="checkbox"/> Yes <input type="checkbox"/> No Measurement:</p> <p><input checked="" type="checkbox"/> Yes <input type="checkbox"/> No Measurement:</p>		<p>Photo #: 29</p>	<p>* If constructed before 3/15/2012 grab bars do not need to be relocated; there are no space requirements above and below grab bars in the 1991 Standards</p>
<p>3.35 If the flush control is hand operated, is the operable part located no higher than 48 inches above the floor?</p>	<p><input type="checkbox"/> Yes <input type="checkbox"/> No Measurement:</p>		<p>NA</p> <p>Photo #: 29</p>	<ul style="list-style-type: none"> • Move control • Install sensor with override button no higher than 48 inches •
<p>3.36 If the flush control is hand operated, can it be operated with one hand and without tight grasping, pinching, or twisting of the wrist?</p> <p>Is the force required to activate the flush control no greater than 5 pounds?</p>	<p><input type="checkbox"/> Yes <input type="checkbox"/> No Measurement:</p> <p><input type="checkbox"/> Yes <input type="checkbox"/> No Measurement:</p>		<p>NA</p> <p>Photo #: 29</p>	<ul style="list-style-type: none"> • Change control • Adjust control •

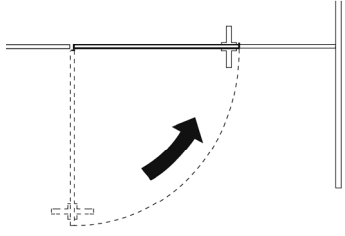
<p>3.37 Is the flush control on the open side of the water closet?</p>	<p><input type="checkbox"/> Yes <input type="checkbox"/> No</p>		<p style="text-align: center;">NA</p> <p>Photo #: 29</p>	<ul style="list-style-type: none"> • Move control • •
<p>3.38 Is the toilet paper dispenser located no less than 7 inches and no greater than 9 inches from the front of the water closet to the centerline of the dispenser?*</p>	<p><input type="checkbox"/> Yes <input checked="" type="checkbox"/> No</p> <p>Measurement:</p>		<p>Photo #: 29</p>	<p>* If constructed before 3/15/2012 dispenser does not need to be relocated if it is within reach from the water closet seat; the 1991 Standards do not specify distance from the front of the water closet</p> <ul style="list-style-type: none"> • Relocate dispenser • •
<p>3.39 Is the outlet of the dispenser:</p> <p>Located no less than 15 inches and no greater than 48 inches above the floor?</p> <p>Not located behind grab bars?</p>	<p><input checked="" type="checkbox"/> Yes <input type="checkbox"/> No</p> <p>Measurement:</p> <p><input type="checkbox"/> Yes <input checked="" type="checkbox"/> No</p>		<p>Photo #: 29</p>	<ul style="list-style-type: none"> • Relocate dispenser • •

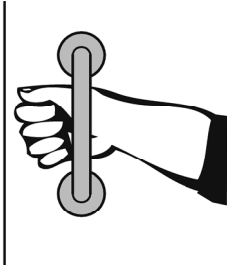
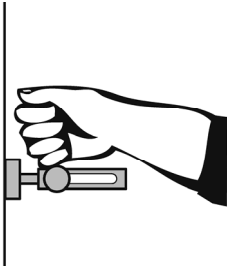
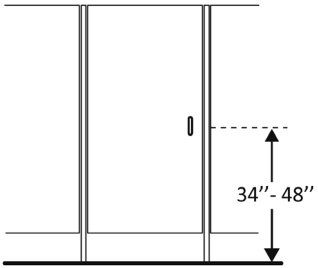
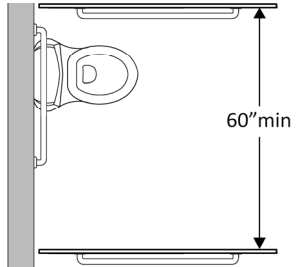
<p>3.40 Does the dispenser allow continuous paper flow?</p>	<p><input checked="" type="checkbox"/> Yes <input type="checkbox"/> No</p>		<p>Photo #:</p>	<ul style="list-style-type: none"> • Adjust dispenser • Replace dispenser •
--	--	---	-----------------	--

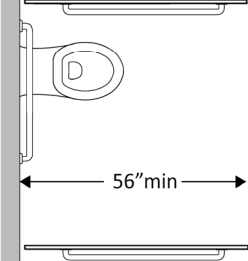
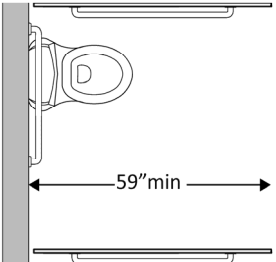
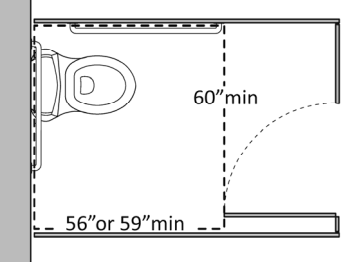
Toilet Compartments (Stalls) (2010 Standards – 604)

<p>3.41 Is the door opening width at least 32 inches clear, between the face of the door and the stop, when the door is open 90 degrees?</p>	<p><input checked="" type="checkbox"/> Yes <input type="checkbox"/> No</p> <p>Measurement:</p>		<p>Photo #: 30</p>	<ul style="list-style-type: none"> • Widen door width • •
---	--	--	---------------------------	--

<p>3.42 If there is a front approach to the pull side of the door, is there at least 18 inches of maneuvering clearance beyond the latch side plus 60 inches clear depth?*</p>	<p><input checked="" type="checkbox"/> Yes <input type="checkbox"/> No</p> <p>Measurement:</p>		<p>Photo #: 30</p>	<p>*See 2010 Standards 604.8.1.2 Doors for maneuvering clearance requirements on the push side of the door and side approaches to the pull side of the door</p> <ul style="list-style-type: none"> • Remove obstructions •
---	--	---	---------------------------	--

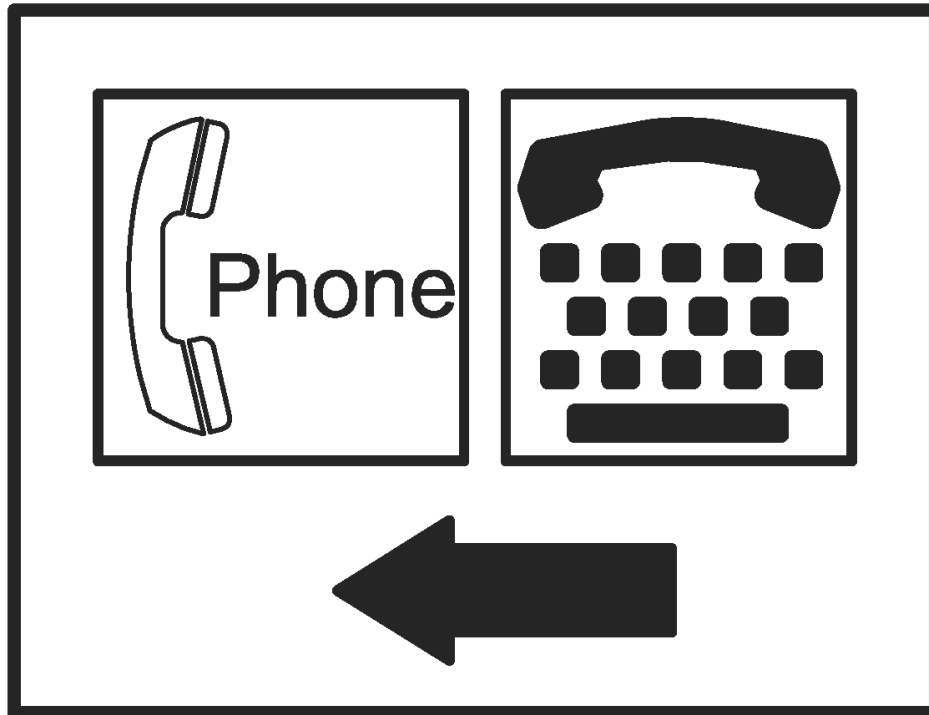
<p>3.43 Is the door self-closing?</p>	<p><input type="checkbox"/> Yes <input checked="" type="checkbox"/> No</p>		<p>Photo #: 30</p>	<ul style="list-style-type: none"> • Add closer • Replace door •
--	--	--	---------------------------	---

<p>3.44 Are there door pulls on both sides of the door that are operable with one hand and do not require tight grasping pinching or twisting of the wrist?*</p>	<p><input checked="" type="checkbox"/> Yes <input type="checkbox"/> No</p>		<p>Photo #: 30</p>	<p>* If constructed before 3/15/2012 door pulls do not need to be added; door pulls are not required in the 1991 Standards</p> <ul style="list-style-type: none"> • Replace hardware • •
<p>3.45 Is the lock operable with one hand and without tight grasping, pinching or twisting of the wrist?</p>	<p><input checked="" type="checkbox"/> Yes <input type="checkbox"/> No</p>		<p>Photo #: 30</p>	<ul style="list-style-type: none"> • Replace lock • •
<p>3.46 Are the operable parts of the door hardware mounted no less than 34 inches and no greater than 48 inches above the floor?</p>	<p><input checked="" type="checkbox"/> Yes <input type="checkbox"/> No</p> <p>Measurement:</p> <p>41 1/2"</p>		<p>Photo #: 30</p>	<ul style="list-style-type: none"> • Relocate hardware • •
<p>3.47 Is the compartment at least 60 inches wide?</p>	<p><input checked="" type="checkbox"/> Yes <input type="checkbox"/> No</p> <p>Measurement:</p>		<p>Photo #: 29</p>	<ul style="list-style-type: none"> • Widen compartment • •

<p>3.48 If the water closet is wall hung, is the compartment at least 56 inches deep?</p>	<p><input type="checkbox"/> Yes <input type="checkbox"/> No</p> <p>Measurement:</p>		<p>SEE PRIORITY 2 SECTION</p> <p>Photo #:</p>	<ul style="list-style-type: none"> • Widen compartment • •
<p>3.49 If the water closet is floor mounted, is the compartment at least 59 inches deep?</p>	<p><input type="checkbox"/> Yes <input type="checkbox"/> No</p> <p>Measurement:</p>		<p>SEE PRIORITY 2 SECTION</p> <p>Photo #:</p>	<ul style="list-style-type: none"> • Alter compartment • •
<p>3.50 If the door swings in, is the minimum required compartment area provided beyond the swing of the door (60 inches x 56 inches if water closet is wall hung or 59 inches if water closet is floor mounted)?</p>	<p><input type="checkbox"/> Yes <input type="checkbox"/> No</p> <p>Measurement:</p>		<p>SEE PRIORITY 2 SECTION</p> <p>Photo #:</p>	<ul style="list-style-type: none"> • Reverse door swing • Alter compartment •
	<p><input type="checkbox"/> Yes <input type="checkbox"/> No</p>		<p>Photo #:</p>	<ul style="list-style-type: none"> • • •
	<p><input type="checkbox"/> Yes <input type="checkbox"/> No</p>		<p>Photo #:</p>	<ul style="list-style-type: none"> • • •

ADA Checklist for Readily Achievable Barrier Removal

Priority 4 – Additional Access



Project **SDDOT Rest Area Improvements**

FHU Reference Number 13-039-01

TSP Project Number 03120855

Building **TILFORD EAST**

Location **90 E., MRM 41**

Date **09-19-2013 (Inspection)**

Surveyors **Timothy Roach, AIA**

Todd Schultz, PE

Contact Information **TSP – (605) 343-6102**

Amenities such as drinking fountains and public telephones should be accessible to people with disabilities.



Institute for Human Centered Design

www.HumanCenteredDesign.org

November 2011



ADA National Network

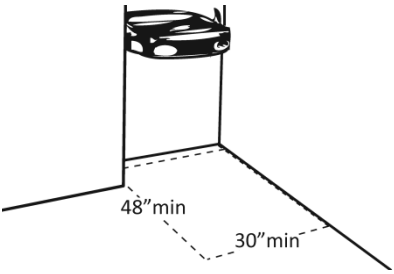
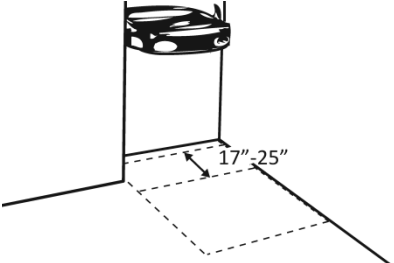
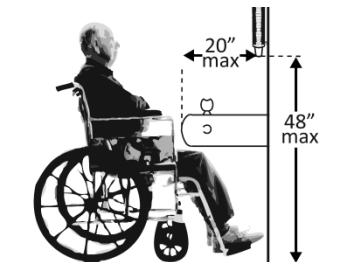
Questions on the ADA 800-949-4232 voice/tty

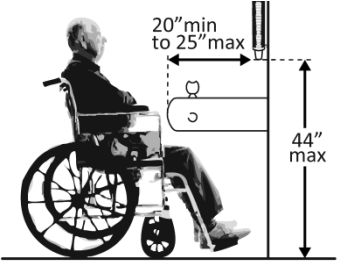

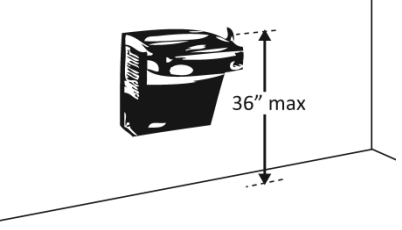
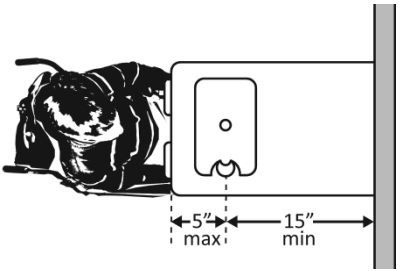
www.ADAchecklist.org

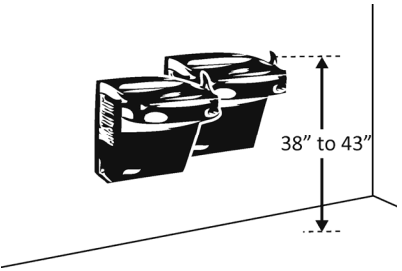
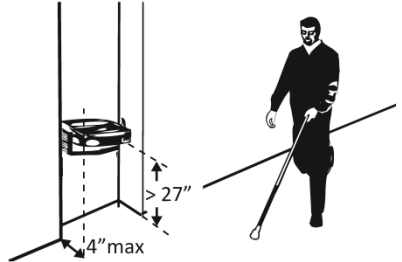
This checklist was produced by the New England ADA Center, a project of the Institute for Human Centered Design and a member of the ADA National Network. This checklist was developed under a grant from the Department of Education, NIDRR grant number H133A060092-09A. However the contents do not necessarily represent the policy of the Department of Education, and you should not assume endorsement by the Federal Government.

Questions or comments on the checklist contact the New England ADA Center at 617-695-0085 voice/tty or ADAinfo@NewEnglandADA.org

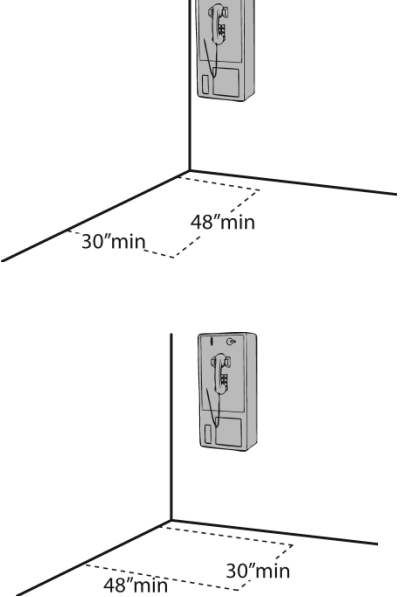
For the full set of checklists, including the checklists for recreation facilities visit www.ADAchecklist.org.

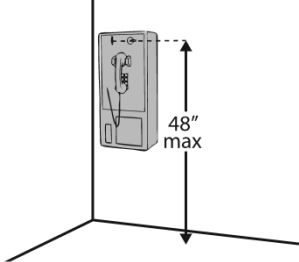
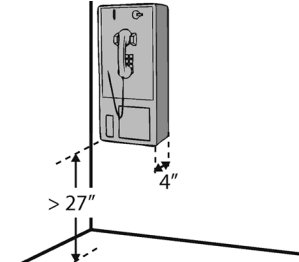


Priority 4 – Additional Access		Comments	Possible Solutions
Drinking Fountains (2010 Standards – 602)			
<p>4.1 Does at least one drinking fountain have a clear floor space at least 30 inches wide x at least 48 inches long centered in front of it for a forward approach?*</p>	<p><input checked="" type="checkbox"/> Yes <input type="checkbox"/> No</p> <p>Measurement:</p>	 <p>48" min 30" min</p>	<p>• 30" WIDE CLEARANCE</p> <p>Photo #: 31</p> <p>*If installed before 3/15/2012, a parallel approach is permitted and the clear floor space is not required to be centered</p> <ul style="list-style-type: none"> • Alter space • Relocate drinking fountain • Install a drinking fountain in another location
<p>4.2 If there is a forward approach, do no less than 17 inches and no greater than 25 inches of the clear floor space extend under the drinking fountain?</p>	<p><input type="checkbox"/> Yes <input type="checkbox"/> No</p> <p>Measurement:</p>	 <p>17"-25"</p>	<p>Photo #: NA</p> <ul style="list-style-type: none"> • Alter space • Replace drinking fountain •
<p>4.3 If the drinking fountain is no deeper than 20 inches, are the operable parts no higher than 48 inches above the floor?</p>	<p><input type="checkbox"/> Yes <input checked="" type="checkbox"/> No</p> <p>Measurement:</p>	 <p>20" max 48" max</p>	<p>Photo #: 31</p> <ul style="list-style-type: none"> • Adjust drinking fountain • Replace drinking fountain •




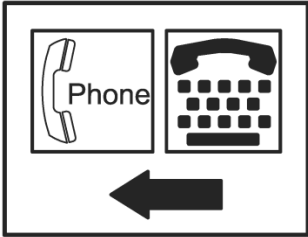
<p>4.4 If the drinking fountain is no less than 20 inches and no greater than 25 inches deep, are the operable parts no higher than 44 inches above the floor?</p>	<p><input type="checkbox"/> Yes <input type="checkbox"/> No</p> <p>Measurement:</p>		<p style="text-align: center; color: red; font-weight: bold;">NA</p> <p>Photo #:</p>	<ul style="list-style-type: none"> • Adjust drinking fountain • Replace drinking fountain •
<p>4.5 Can the control be operated with one hand and without tight grasping, pinching or twisting of the wrist?</p> <p>Is the force required to activate the control no more than 5 pounds?</p>	<p><input checked="" type="checkbox"/> Yes <input type="checkbox"/> No</p> <p><input checked="" type="checkbox"/> Yes <input type="checkbox"/> No</p> <p>Measurement:</p>		<p>Photo #: 31</p>	<ul style="list-style-type: none"> • Change control • Adjust control •
<p>4.6 Is the spout outlet no higher than 36 inches above the floor?</p>	<p><input checked="" type="checkbox"/> Yes <input type="checkbox"/> No</p> <p>Measurement:</p>		<p>Photo #: 32</p>	<ul style="list-style-type: none"> • Adjust drinking fountain • Replace drinking fountain •
<p>4.7 Is the spout:</p> <p>At least 15 inches from the rear of the drinking fountain?</p> <p>No more than 5 inches from the front of the drinking fountain?</p>	<p><input checked="" type="checkbox"/> Yes <input type="checkbox"/> No</p> <p>Measurement:</p> <p><input checked="" type="checkbox"/> Yes <input type="checkbox"/> No</p> <p>Measurement:</p>		<p>Photo #: 32</p>	<ul style="list-style-type: none"> • Adjust spout • Replace drinking fountain •



<p>4.8 If there is more than one drinking fountain, is there at least one for standing persons?</p> <p>Is the spout outlet no lower than 38 inches and no higher than 43 inches above the floor?</p>	<p><input type="checkbox"/> Yes <input checked="" type="checkbox"/> No</p> <p><input checked="" type="checkbox"/> Yes <input type="checkbox"/> No</p> <p>Measurement:</p>		<p>Photo #: 32</p>	<ul style="list-style-type: none"> • Adjust drinking fountain • Install new drinking fountain for standing height •
<p>4.9 If the leading (bottom) edge of the fountain is higher than 27 inches above the floor, does the front of the fountain protrude no more than 4 inches into the circulation path?</p>	<p><input type="checkbox"/> Yes <input checked="" type="checkbox"/> No</p> <p>Measurement:</p>		<p>Photo #: NA</p>	<ul style="list-style-type: none"> • Adjust drinking fountain • Replace drinking fountain • Add tactile warning such as permanent planter or partial walls

Public Telephones (2010 Standards – 704) TTY's are devices that employ interactive text-based communication through the transmission of coded signals across the telephone network. They are mainly used by people who are deaf and/or cannot speak.


<p>4.10 Does at least one telephone have a clear floor space at least 30 inches wide x at least 48 inches long for a parallel or forward approach?</p>	<p><input checked="" type="checkbox"/> Yes <input type="checkbox"/> No</p>		<p>Photo #: 33</p>	<ul style="list-style-type: none"> • Move telephone • Install new telephone for clear floor space •
---	--	---	---------------------------	--

<p>4.11 Is the highest operable part of the telephone no higher than 48 inches above the floor?</p>	<p><input checked="" type="checkbox"/> Yes <input type="checkbox"/> No Measurement:</p>		<p>Photo #: 33</p>	<ul style="list-style-type: none"> • Adjust telephone • •
<p>4.12 If the leading (bottom) edge of the telephone is higher than 27 inches above the floor, does the front of the telephone protrude no more than 4 inches into the circulation path?</p>	<p><input type="checkbox"/> Yes <input checked="" type="checkbox"/> No Measurement:</p>		<p>Photo #: 33</p>	<ul style="list-style-type: none"> • Adjust telephone • •
<p>4.13 Does at least one telephone have a volume control?</p>	<p><input type="checkbox"/> Yes <input checked="" type="checkbox"/> No</p>		<p>Photo #: 33</p>	<ul style="list-style-type: none"> • Install volume control • Replace telephone with one that has volume control •
<p>4.14 Is the volume control identified by a pictogram of a telephone handset with radiating sound waves?</p>	<p><input type="checkbox"/> Yes <input checked="" type="checkbox"/> No</p>		<p>Photo #: 33</p>	<ul style="list-style-type: none"> • Add pictogram • •

<p>4.15 Does at least one telephone have a TTY?</p>	<p><input type="checkbox"/> Yes <input checked="" type="checkbox"/> No</p>		<p>Photo #: 33</p>	<ul style="list-style-type: none"> • Install TTY • •
<p>4.16 Is the touch surface of the TTY keypad at least 34 inches above the floor?</p>	<p><input type="checkbox"/> Yes <input type="checkbox"/> No Measurement:</p>		<p>Photo #: NA</p>	<ul style="list-style-type: none"> • If a seat is provided, TTY is not required to be 34 inches minimum above the floor • Adjust height of TTY •
<p>4.17 Is the TTY identified by the International Symbol of TTY?</p>	<p><input type="checkbox"/> Yes <input type="checkbox"/> No</p>		<p>Photo #: NA</p>	<ul style="list-style-type: none"> • Add symbol • •
<p>4.18 Do signs that provide direction to public telephones also provide direction to the TTY?</p>	<p><input type="checkbox"/> Yes <input type="checkbox"/> No</p>		<p>Photo #: NA</p>	<ul style="list-style-type: none"> • Add signs • •

<p>4.19 Do telephones that do not have a TTY provide direction to the TTY?</p>	<input type="checkbox"/> Yes <input type="checkbox"/> No	 	<p style="text-align: center; color: red; font-weight: bold;">NA</p> <p>Photo #:</p>	<ul style="list-style-type: none"> • Add signs • •
---	--	---	--	---

Fire Alarm Systems (2010 Standards – 702)

<p>4.20 If there are fire alarm systems, do they have both flashing lights and audible signals?</p>	<input type="checkbox"/> Yes <input type="checkbox"/> No		<p style="text-align: center; color: red; font-weight: bold;">NA</p> <p>Photo #:</p>	<ul style="list-style-type: none"> • Install audible and visual alarms • •
	<input type="checkbox"/> Yes <input type="checkbox"/> No		<p>Photo #:</p>	<ul style="list-style-type: none"> • • •
	<input type="checkbox"/> Yes <input type="checkbox"/> No		<p>Photo #:</p>	<ul style="list-style-type: none"> • • •
	<input type="checkbox"/> Yes <input type="checkbox"/> No		<p>Photo #:</p>	<ul style="list-style-type: none"> • • •

TILFORD EAST PRIORITY 1



Photo #1



Photo #2



Photo #3



Photo #4

TILFORD EAST PRIORITY 1



Photo #5

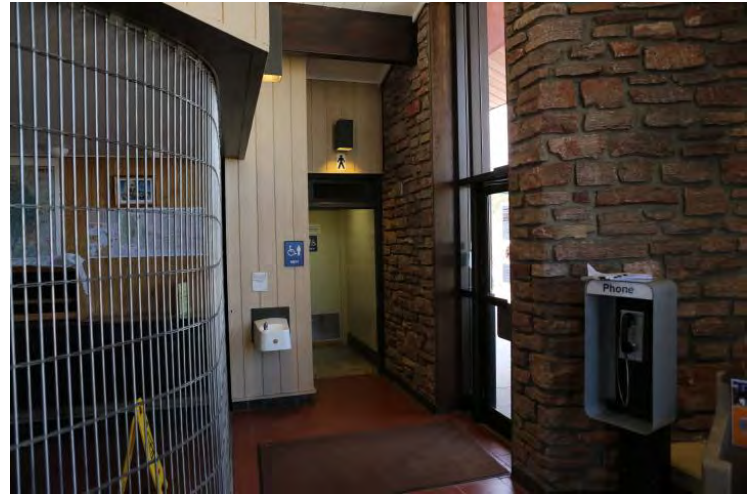


Photo #6



Photo #7

TILFORD EAST PRIORITY 2

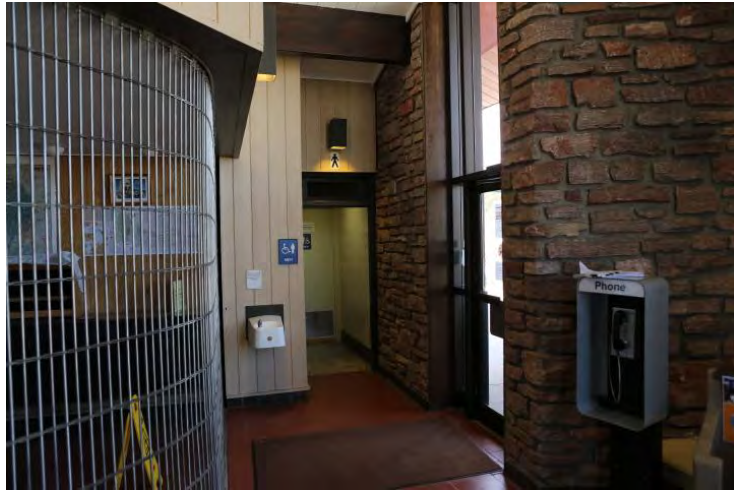


Photo #6



Photo #8



Photo #9



Photo #10

TILFORD EAST PRIORITY 2

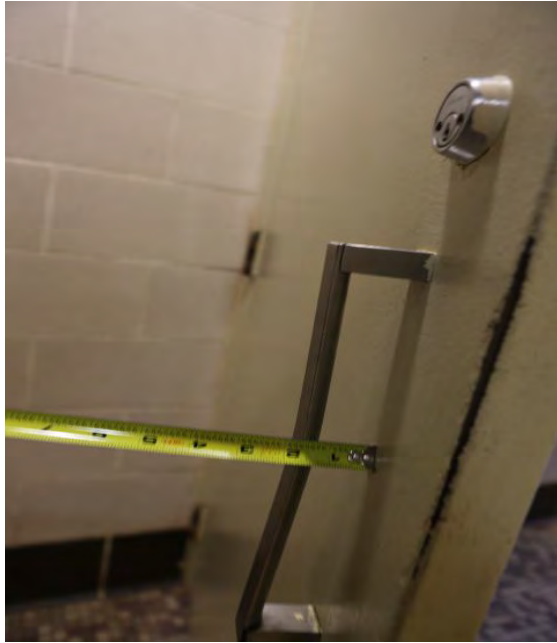


Photo #11



Photo #12



Photo #13

TILFORD EAST PRIORITY 3 – Men's



Photo #13



Photo #14



Photo #15



Photo #16

TILFORD EAST PRIORITY 3 – Men's



Photo #17



Photo #18



Photo #19



Photo #20

TILFORD EAST PRIORITY 3 – Women's

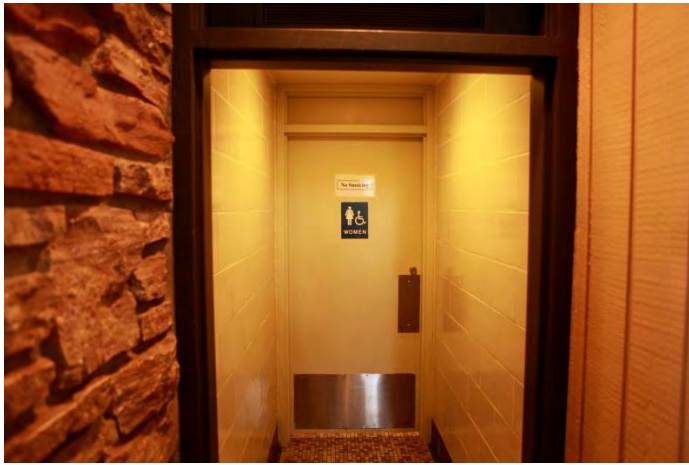


Photo #21



Photo #22

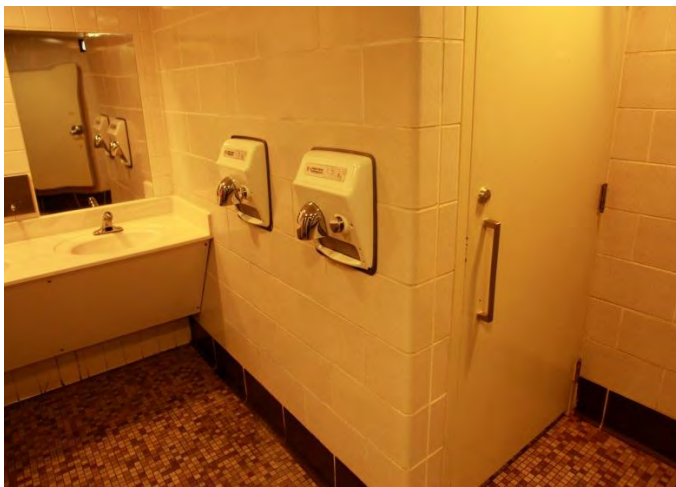


Photo #23

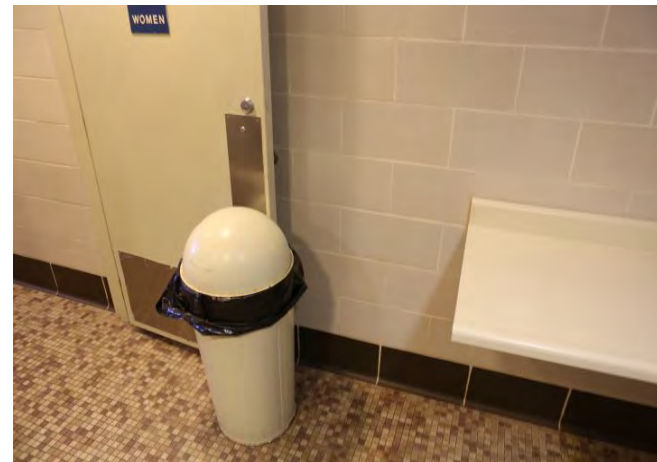


Photo #24

TILFORD EAST PRIORITY 3 – Women's



Photo #25



Photo #26



Photo #27



Photo #28

TILFORD EAST PRIORITY 3 – Women's



Photo #29



Photo #30

TILFORD EAST PRIORITY 4

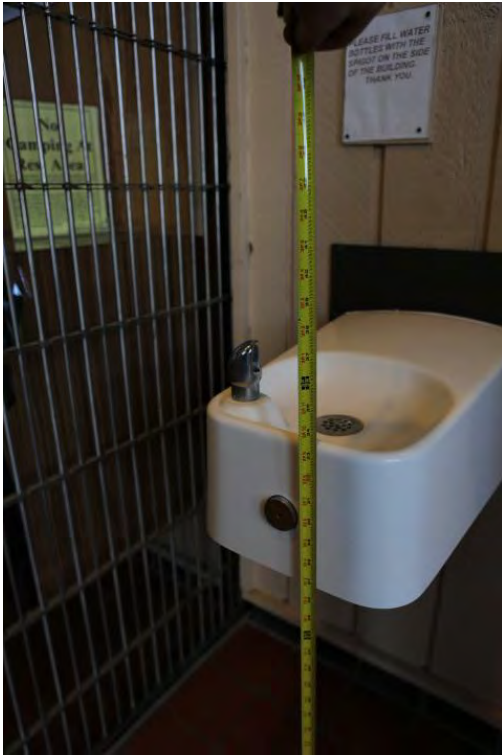


Photo #31



Photo #32

TILFORD EAST PRIORITY 4



Photo #33



The Interstate Rest Areas Study: Along the I-29 and I-90 Corridors

APPENDIX C AUDITMATE SUMMARY

Detailed Component List for One Facility
TILF_RAE Tilford Rest Area East

\$41,542

Class	Component	Comment	Quantity	Unit Cost	Lifespan	Age	Installed	Renewal Cost (RC)	Deferred Cost (DC)
Site Structures									
	Utility Storage Shed	roughly 10x12 used for visitor document storage. It is old, but in working condition.	1	\$10,000.00	15	15?		\$10,000	
	Reinforced Concrete Picnic Shelter	30x30 good condition. At this age facility will need routine structural inspection	1	\$30,000.00	75	37	1966	\$30,000	
	Precast Concrete Picnic Shelter	Structures need routine structural inspection of welded plate connections and minor repairs to plates, concrete, and paint	4	\$5,000.00	75	37	1966	\$20,000	
	Reinforced Concrete Picnic Tables	Tables appear to be in good condition	12	\$4,000.00	75	37	1966	\$48,000	
	Information Display (outdoor)	Appears to be in good condition			20				
Exterior Closure									
	Insulated Stone Wall System	No evident of heavy wear, cracking, or spalling			75	40	1973		
	CMU Exterior Wall (uninsulated)	No evident of heavy wear, cracking, or spalling			75	40	1966		
	Masonry Wall Mortar & CMU Wall	Good condition. Tuck-pointing seems to have been completed over the years. Recommend mason inspection, tuck-pointing, and caulking			65	47	1966		
	Paint or Stain Exterior (CMU)	Existing paint seems only a few years old and not original (as shown in AuditMate). Touch up recommended at base.			10	5?	1989		
	Paint Exterior (Soffits, Trim and Service Door)	Existing paint seems only a few years old and not original.			10	5?	1989		
	Steel Double Door (uninsulated)	Good working order. Needs painting.			30	24	1989		
	Storefront Single Door (alum. & Glass)	Life span 10 years in heavy use (not 50) - fair condition. Needs threshold and new pull hardware (ADA). Should replace with insulating glass. Door doesn't appear to be original.			15	10?	1973		
	Alum. Frame & Glazing - Storefront Uninsul.	In fair condition - Inspect and replace sealants periodically. Should replace with insulating glass & frame system.			45	40	1973		
	Alum. Frame & Glazing - Windows Uninsul.	Fair condition but old			45	40	1973		
	Glass Block Windows	8 @ 16" x 16" - Fair condition but old	8		60	47	1966		
Roofing and Drainage									
	Galvanized Metal Roof, Standing Seam, Factory Finish	Good condition, some sagging apparent at long spans. Recommend structural engineer review while reviewing picnic shelters. New system replaced existing built up roof system.		\$25.00/sf					
	Downspouts, Galvanized Steel, Factory Finish			\$10/sf					

Detailed Component List for One Facility
TILF_RAE Tilford Rest Area East

\$41,542

Class	Component	Comment	Quantity	Unit Cost	Lifespan	Age	Installed	Renewal Cost (RC)	Deferred Cost (DC)
	Gutters, Galvanized Steel, Hung	Replaced existing internal roof drain system. New system appears to be in good condition.		\$10/sf					
Interior Construction									
	Painting, Interior, Average Grade	Recalculate SF in AuditMate to include Lobby walls and ceilings, restroom ceilings, maintenance areas.							
	Ceramic Tile Floor (restrooms 1/2"x1/2 ")	Recommend deep cleaning & minor repairs at a minimum. Replacement preferred.							
	Epoxy Paint Floor Quarry Tile Floor (Lobby 6"x6")	Abrasive grain is worn off - floors will get slippery. Recommend replacement in high traffic areas. At a minimum, clean grout and some replacement tile needed (10 sf).			20				
	Toilet Stall Door, Metal, Baked Enamel Finish	Seem original but in fair shape. Could use refinishing							
	Interior Doors and Hardware		2		20				
	SS Security Gate Assembly	Needs replacement ASAP			35	40	1973		
	Information Desk & Map Counter	Needs replacement ASAP			20	40	1973		
Plumbing									
	Sewage Ejection Pump, Duplex, 2" Discharge, Over	There are no reported issues.							
	Tank, Holding Tank, 5000 gallons	There are no reported issues. Suggest periodically testing for bacterial growth in the tanks.							
	Water Softening System, Residential	There are no reported issues. Assuring that the water softener is regenerated properly will help to extend the life of the resin. Resin can gel if not periodically and continuously regenerated.							
	Well Pressure tank, Medium	Tank appears to be in good condition							
	Well Pump	Delete line item - well is located at Tilford East Side	1-each	\$640.00	25	11	2002	\$640	\$0
	Water Fountain, Porcelain	Needs minor valve repair							
	Water Heater, Residential, Electric 20-50 gallons	Appears to be in good condition. Occasionally blowing the bottom out to remove residue and scale may add another 2 years to its life.							
	Cabinet Countertop, Corian, w/Integral sink								
	Faucets (Lav)	Maintain water quality, and regular maintenance and cleaning will help extend the faucets life							
	Faucets (Lav)	Maintain water quality, and regular maintenance and cleaning will help extend the faucets life							

Detailed Component List for One Facility
TILF_RAE Tilford Rest Area East

\$41,542

Class	Component	Comment	Quantity	Unit Cost	Lifespan	Age	Installed	Renewal Cost (RC)	Deferred Cost (DC)
	Urinals, Porcelain, Wall-Hung	Appear to be in good condition for their age. Replacing units with low water consumption units will extend the life of the lagoon and pumps.							
	Water Closet, Porcelain, Wall-Hung	Replacing units with low water consumption units will extend the life of the lagoon and pumps							
	Waste and Vent Piping	Appears to be in good condition, no apparent leaks			50	40	1973		
	Water Piping	Appears to be in good condition			65	40	1973		
	Piping Insulation	Is in poor condition and should be replaced within the next year. Sweating pipes were observed where insulation was damaged, which in turns damages the remaining insulation. Dripping is also a nuisance in the mechanical room and some water damage occurs to other equipment			30	40	1973		
	Valves	Valves are starting to exhibit some corrosion.			45	40	1973		
	Pipe Hangers and Supports	Appear to be in good condition. Should last another 25 years if humidity is controlled by proper ventilation.			65	40	1973		
Mechanical									
	Furnace - Propane	Furnace is 2 years old and appears to be in good condition.			40	2	2011		
	AC Split System Outdoor Condensing, 05 Ton	Unit should be replaced in the near future. The unit has considerable hail damage to the fins, which affects its performance.							
	Air Handling Unit, Split System AC/Gas heat, 05 Ton	Electric unit heater appears to be in adequate condition. However, the unit is 40 years old and should be replaced in the near future. It is difficult to determine the condition of electric hearing elements, and this is the only source of heat in the mechanical room where water piping exists, and may freeze if the heater fails.							
	In-Line Exhaust fan	Unit is in good condition for its age.							
	Unit Heater, Electric, Ceiling or Wall Mounted								
	Hydronic Circulating Pump, Base-Mounted, 005 HP	Is in good condition. Should last another 5 years			25	20	2000		
	Humidifier, Electric, Portable, Small								
	Ductwork and Grilles	Units are in adequate condition and will last another 10 years. No adjustments required to AuditMate.			50	40	1973		
	Temperature Controls	Programmable Thermostat is in good working condition.			60	40	1973		

Detailed Component List for One Facility
TILF_RAE Tilford Rest Area East

\$41,542

Class	Component	Comment	Quantity	Unit Cost	Lifespan	Age	Installed	Renewal Cost (RC)	Deferred Cost (DC)
Electrical									
	Well Monitoring System	Understand in good condition	1 each	\$3,200.00	40	11	2002	\$3,200	\$0
	Phone Unit	Floor Mount, replace - Non ADA compliant							
Utilities									
	A/G Fuel, Steel Tank 0-100								
Sanitary Sewer System									
	Lagoons (3, note 1 supports Tilford east)	The lagoons are scheduled to be overhauled by the SDDOT in a separate project							
	Sewage Piping System	No reported problems (4" diameter pipe across interstate to Tilford East Bound							
Water System (well)									
	Water Pipe System	3" water line - no reported problem							
Infrastructure									
	Parking Area, Non Reinforced Concrete 9.5"	Continue periodic joint repair and sealing. May need to replace 2 or 3 panels in the next 5 years.							
	Roadway, Asphalt	Asphalt Pavement behind main building, used for handicapped parking, needs to have cracks repaired and the surface chip or slurry sealed. The shoulders along the concrete pavement should have a seal coat applied in the near future.							
	Sidewalk, Concrete	Concrete stairs need maintenance or replacement. The treads of the steps are deteriorating. Approximately 10% of the walks will need replacement in the next 5 - 10 years. Most of this replacement will be near the building and flagpole. The stone wall at the bottom of the steps needs repair or replacement. The lower walk along the parking spaces will need approximately 20% replaced in the next 5 - 10 years, mostly to the north of the stairs.							
	Landscaping	Landscaping for the site appears to be in good shape (this site visit occurred prior to the snowstorm of October 4-5, 2013). Grass is well kept and trees appear to be healthy. The sprinkler system is in good working order with only yearly maintenance required. Refreshing of landscaping should be considered at some point.							

Detailed Component List for One Facility
TILF_RAE Tilford Rest Area East

\$41,542

Class	Component	Comment	Quantity	Unit Cost	Lifespan	Age	Installed	Renewal Cost (RC)	Deferred Cost (DC)
	Wayfinding Signage	Existing signs appear to be in good shape, but could use modernization							
	Site Lighting - Parking	Replaced a "few years ago".							
	Site Lighting - Pedestrian	Replaced a "few years ago".							

**TILFORD WESTBOUND
REST AREA
TECHNICAL REVIEW REPORT**

Prepared for:

Mr. Brad Remmich
South Dakota Department of Transportation
Office of Project Development
700 East Broadway Avenue
Pierre, SD 57501-2586
(605) 773-3093

Prepared by:

TSP
600 Kansas City Street
Rapid City, SD 57701-2712
(605) 343-6102

Felsburg Holt & Ullevig
6300 South Syracuse Way, Suite 600
Centennial, CO 80111
(303) 721-1440

FHU Reference No. 113039-01
December 2013



The Interstate Rest Areas Study: Along the I-29 and I-90 Corridors

TABLE OF CONTENTS

	<u>Page</u>
I. INTRODUCTION -----	1
II. GENERAL OVERVIEW -----	2
A. Rest Area Layout -----	2
B. Field Visit Observations -----	4
C. User Environment -----	4
D. Existing Building Code Conformity -----	5
E. Americans with Disabilities Act (ADA) Survey -----	5
F. Energy and Water Usage Review -----	6
III. BUILDING SYSTEM OVERVIEW -----	7
A. Architectural System -----	7
B. Plumbing System -----	7
C. Mechanical System -----	8
D. Electrical System -----	8
E. Sanitary Sewer System -----	8
F. Water System -----	9
G. Infrastructure -----	9
IV. SUMMARY -----	10

APPENDIX A MAINTENANCE STAFF MEETING MINUTES

APPENDIX B ADA SURVEY RESULTS

APPENDIX C AUDITMATE SUMMARY

LIST OF FIGURES

	<u>Page</u>
Figure 1. Tilford Westbound Rest Area Site Layout -----	3



I. INTRODUCTION

The Tilford Westbound Rest Area is located along Interstate 90, approximately 16 miles north and west of the Rapid City, South Dakota metropolitan area. The rest area has direct access from Interstate 90 and provides one centralized parking lot for both passenger vehicles and trucks visiting the site.

The purpose of this report is to summarize the condition of existing site components and building systems for the facility as a whole. The intent for this report is to define the general status of the existing facilities given their age and use.

The report has been divided into two general areas of focus. The first section includes a general overview of the facility design and operations. Architectural issues, including the general capacity of the facilities and current operations, are reviewed and compared to current facility standards (i.e., building codes, ADA, etc.).

The systems overview section covers the type and condition of the components that make up the facility, and includes a summary evaluation of the site and building infrastructure. The site infrastructure repairs/replacement review includes sidewalks, lighting, signage, landscaping, and picnic shelters. The building systems infrastructure review includes items such as the building shell and structure, mechanical and plumbing systems, electrical, interior finishes, and communications/IT equipment.



II. GENERAL OVERVIEW

A. Rest Area Layout

The site is narrow and long paralleling Interstate 90 which runs north to south at this location. The main building is located to the north and east of the parking lot. South of the building is the picnic area. The parking lot parallels the rest area on the west, and sits at approximately five feet above the entrance for the main facility. There is a separate parking lot to the north of the building that provides two accessible parking spaces.

Outdoor facilities include:

- Four precast 25'x25' teepee picnic shelters supporting one table each
- One 30'x30' main covered structure supporting four tables
- Three integral reinforced concrete tables/bench sets on concrete slabs are placed throughout the site
- Dumping station
- Portable utility shed approx. 10'x12' for tourism storage
- Portable utility shed approx. 10'x20' for equipment
- Exterior visitor display structure
- Exterior uncovered vending machines and advertising equipment
- Built in benches at building
- Flag pole

Utilities Include:

- Well and water system located at the Tilford Eastbound Rest Area
- Gravity sewer system with lagoons located on site
- Power is three phase 208 volt, 0200-0250 amp
- 500 gallon propane gas tank

The 1,641 square foot facility includes the following:

- Lobby, and secured visitor center
- Men's and women's restrooms
- Mechanical, maintenance and storage area

Figure 1 shows the layout of the Tilford Westbound Rest Area facility including the rest area's location in relation to major roadways in the area.



The Interstate Rest Areas Study: Along the I-29 and I-90 Corridors



Figure 1. Tilford Westbound Rest Area Site Layout



B. Field Visit Observations

A field meeting was held with TSP and SDDOT officials on September 19, 2013 to gain initial insights from the SDDOT maintenance team about the operation, history, and condition of the existing on-site facilities at the Tilford Westbound Rest Area. A copy of the meeting minutes are contained in **Appendix A** of this report, and the following summarizes the key points of the meeting:

- The facility was designed and constructed in 1973 and since this time it has only been only partially upgraded to meet current industry standards (ADA requirements, building codes).
- The facility appears to have been designed for seasonal use, has not been winterized / insulated and has limited mechanical systems.
- Pedestrian access from the main building to the parking lot is difficult. The main building is located at the north end of the parking lot with the entrance approximately five feet lower than the parking lot.
- The existing ADA parking area is separated from the main lot on the north side of the main building.
- The Information lobby area is very small, with minimal circulation area and clearances. This area has limited opportunities for increased use or expansion.
- Storage space for the tourist information center appears insufficient and not accessible per ADA.
- Each restroom provides four stalls and three sinks, with little space for circulation.
- A septic smell from sewage ponds was observed. Often, the odors are so strong they can be smelled from highway (but are more enhanced at parking/picnic areas). This issue is addressed further in the report.

C. User Environment

Architecturally, the facility is an inviting modern rustic facility with an interesting form, a thoughtful use of natural materials (including stone, wood and tile). In its design it seems to appropriately reflect the culture of the Black Hills.

Recent roof changes has eliminated daylight to the lobby space from the back of the building which should also be noted and reviewed.

The four exterior 25' x '25' precast picnic shelters, were crudely constructed.



D. Existing Building Code Conformity

The current facilities were designed and constructed in 1973 to the codes at the time which lacked consideration for people with disabilities. To quantify the differences in code standards, the existing main building was evaluated per the ICC 2012 International Building Code which has been adopted by the State of South Dakota. Based on the use of the existing facility, the following building classifications were utilized in the comparison:

- Size: 1,641 square feet
- Occupant Type: Mercantile
- Construction Type: Type 3-b (or 5-b)
- Occupant Load: < 50
- Maximum access travel: 75 feet
- Required Exits: 1

The following outline the major areas where the existing building deviates from the requirements of the current Building Code (IBC 2012):

- GFI power outlets are not present in restrooms, and the information desk requires additional power connections.
- Ventilation system not set for full time operation.
- Facility does not include a family / assisted-use restroom.
- Several areas are not ADA compliant per ICC A117.1-2009 (outlined in following sections)
- Storage placed around some electrical panels does not meet 36" minimum clearance.

It should be noted that per the "Existing" Building Code, unless there are significant safety hazards, the facilities are not required to be modernized as a whole to meet current code standards. However, any repairs or new additions will need to be completed to these standards. The exception concerns ADA requirements, which are a retroactive federal requirement. When the ADA is addressed the project will need to also be completed per building code, which includes accessibility criteria (ICC- A117.1-2009).

E. Americans with Disabilities Act (ADA) Survey

As stated previously, the building was originally constructed prior to the full implementation of ADA standards. At some time it was partially updated to ADA standards in restrooms (per 1991 Federal Standards). To quantify the current facility compliance with ADA standards, a detailed survey was completed utilizing the "ADA Checklist for Readily Achievable Barrier Removal" per the DOJ ADA Standards for Accessible Design - 2010. The survey identified the following general deficiencies, and more detailed information is referenced in **Appendix B** of this report:

Priority 1 Deficiencies (access to building):

- Accessible parking spaces to rear of the building do not meet maximum slope limitations
- Parking signs do not meet current MUTCD standards
- ADA pull handle on entrance door has insufficient clearance, and an appropriate threshold to cover existing tile edge not provided



The Interstate Rest Areas Study: Along the I-29 and I-90 Corridors

- Way-finding signage to find existing accessible lot does not meet current standards.

Priority 2 Deficiencies (Access to Goods and Services):

- Doorways from the lobby to each of the restrooms do not have sufficient corridor width. There is insufficient ADA clearance with the existing 36" wide corridor when using operable restroom entrance doors (46-52" min. required depending upon configuration).
- Information Area:
 - Area behind counter and information desks / map count height do not meet ADA clearance or height standards.
 - 24" access door to back storage/maintenance area not wide enough (36" minimum). - Storage areas should be accessible as well as some shelving, for those managing the information areas.
 - Signage, upgrade existing signs to current ADA standards.
- Only one of twelve exterior picnic benches has been modified to current ADA standards.

Priority 3 (Restrooms):

- Stall doors not self-closing.
- Men's toilet does not provide 18" clearance from partition.
- Toilet paper holders in men's and women's stalls do not meet standards
- Entrance doors do not meet closure pressure or ADA pull handle standards.

Priority 4 (additional access) Deficiencies:

- Phone is free standing and requires replacement with a new unit to include provisions for sound control, TTY plug in, and shelf.

F. Energy and Water Usage Review

Propane use for 2011 was 857 gallons, equating to 48.7 thousand British thermal units / square feet / year (MBTU/SF/YR). This use data indicates the site uses a reasonable amount of energy for this type of building. Of note, heavy propane use typically exceeds 100 MBTU/SF/YR.

Electrical use for 2012 was 38,655 kilowatts per hour (KWH), equating to 24.2 KWH/SF/YR or 82.5 MBTU/SF/YR. The data suggests a relatively high amount of energy usage for this type of building when compared to industry standards (50 MBTU/SF/YR or 15 KWH/SF/YR). The majority of the electrical use is dedicated to site lighting, well pumps, and sewage pumps, which are normally not included when calculating high energy usage.

Water use averages 850 gallons per day during off-season, and 2200 gallons per day during the tourist season of May through August.



III. BUILDING SYSTEM OVERVIEW

The following sections include a general review of individual building and site components, starting with site components and then broken down by individual disciplines (Architectural Systems, Mechanical, Electrical, Plumbing, and Civil/Site systems). The discussion generally parallels SDDOT AuditMate database format.

A detailed summary of each discipline section in the current AuditMate format including general comments of individual line items are contained in **Appendix C** of this report. The table contains both existing line items and recommended updates to the SDDOT database, which are shown in **bold** font.

A. Architectural System

The original 1966 structure appears to have been a vaulted toilet building including the picnic shelters and benches. The vault building consists of un-insulated reinforced concrete block walls (CMU) and un-insulated precast roof planks. The building was converted to a utility room with the addition of the larger and current facility in 1972. In supplied drawings, a smaller basement vault space of 11' x 16' x 5' high is shown, and was not inspected for this report.

The shell and interior walls are constructed either as stone or as concrete block bearing walls. The roof system above the lobby consists of exposed wood beams and wood plank decking, with conventional wood framing above the restrooms. The back vault area roof structure is constructed of precast planks.

Around 2000, a new metal roof structure was installed over the old wood roof. The existing roofing system appears to have been originally a built-up system. The metal replacement roof was installed at a new slope over the entire facility, including the vault building, and have assumed that insulation and proper venting were included. Internal drains were shut off and a new exterior gutter and drain system was installed.

The year round facility appears to have been originally designed for seasonal summer use. Per the original drawings, the exterior stone bearing walls and restrooms have limited insulation, but the concrete block walls, the roof over the lobby, all windows and the service door remain un-insulated. It was assumed that the new roof installed in 2000 has been insulated.

B. Plumbing System

Wall hung water closets and urinals, and countertop lavatory sinks are vitreous china installed in 1973. Lavatories faucets and water closets flush valves are electronic type, battery operated. There is also a wall hung vitreous china drinking fountain that was installed in 1973.

Waste and vent piping is cast iron, was installed in 1973 as well as copper water piping and some insulation. Much of the water piping insulation is damaged or missing. There is a water bottle filler surface mounted on the outside of the building piped in cross-linked polyethylene (PEX).

Water is supplied from a shallow well and pumped to a 5,000 gallon underground fiberglass holding tank installed in 2001. A well pressure tank was also installed in 2001.



All water is softened with a dual water softener, installed in 2000 and chlorinated with an injector. If left un-softened, hard well water would require maintenance on the system every three years. An electric water heater was installed in 2005. A small water circulator pump, installed in 2002, circulates domestic hot water from the fixtures back to the water heater.

C. Mechanical System

Building is heated and cooled with a ducted system and central air conditioning. The furnace is propane gas fired, installed in 1973, and supplied from a 500 gallon above ground propane tank. The outdoor condensing unit is a Lennox five ton cooling unit (installed 1993) that shows hail damage. Thermostat for the cooling unit is located in the information center.

Exhaust ventilation for the toilet rooms is ducted and exhausted by a single small utility fan set. The fan is controlled by a timer and runs 15 minutes every hour. Exhaust grilles are wall mounted on the water closet wall in each toilet room. Air is exhausted through a wall louver in the mechanical room, and there is no mechanical outside air.

A small electric unit heater provides heat for the mechanical room, and was installed in 1993.

D. Electrical System

The building is served by a three phase 208 volt, 250 amp service. There are two 225 amp panels located the mechanical room. Panels are clearly labeled as to what each breaker serves, and all wiring is run in conduit. Panel boards appeared to be in adequate condition, with no signs of excessive rust or deterioration.

All indoor lighting fixtures are original, and installed in 1973. All lamps contain fluorescent bulbs, and the remaining lighting fixtures in the building are a mix of recessed cans and wall mounted scones in the main lobby, and ceiling recessed mounted fixtures in the restroom. Restroom light fixtures are starting to pull away from the ceiling and may become a source of vandalism.

Outdoor lighting is primarily high pressure sodium or HID. Wall packs are used on the building, and some show signs of moisture inside the lens, indicating the lens is no longer sealing properly. Most outdoor lighting was installed between 1989 and 1997.

Hand dryers are electric and operating properly.

CCTV is installed in the lobby. There is also an emergency beacon system, the operation of which was not immediately observable, but confirmed by staff.

E. Sanitary Sewer System

The sanitary sewer system consists of gravity flow sewer lines to two lagoon located south of the main building. A third lagoon is also located north of the rest area, and primarily serves the Tilford Eastbound Rest Area. All three of the lagoons appear to be the same size (approximately 250'x110'). A lift station is used to alternately pump sewage between the north and south lagoons, allowing waste water flow from both the eastbound and westbound rest areas to be diverted to any of the three lagoons.



According to maintenance personnel, the ponds provide adequate capacity and the lift station is working well. A meter has been suggested by the South Dakota Department of Environment and Natural Resources (DENR) for more accurate determination of flow to each pond. The age and material of the pipe is unknown, but no problems have been detected with the system at this time. The dump station also flows to the lagoon on the north side of the rest area.

A natural problem does occur with the open ponds on either side of the westbound rest area. Depending upon the direction of the winds, the smell of effluent will be present on site and at the outdoor picnic areas. There are times when these smells are extreme as the chemical treatment coming from the dump stations/campers counteracts the treatment at the ponds.

F. Water System

The water well for this site is located on the Tilford Eastbound Rest Area. The water line traverses from the eastbound rest area under the Interstate 90 corridor and serves the Tilford Westbound building. No problems were indicated by the maintenance staff with this system.

G. Infrastructure

The parking area is concrete with some asphalt shoulders along the ramps and asphalt in the handicapped parking area behind the building.

The general condition of the concrete on the ramp and in the parking area is good, with most of the deterioration being in the joints. This is confirmed by the latest pavement ratings done by the SDDOT. In these ratings, joint seals are the lowest rated followed by joint spalling. Joint repair and sealing should be done soon to extend the life of the pavement another 15 years to a life span of 60 years.

Asphalt pavement is used for shoulders along the ramps and paving in the handicapped parking area. The asphalt in the handicapped parking area has some cracking but is in good condition. Sealing the cracks (est. 25% of area) and applying a seal coat (100% of surface) would help extend the life of the asphalt. The asphalt along the ramps has some grass growing in cracks which can lead to additional deficiencies.

Concrete walk extends along the parking spaces, around the building and to picnic shelters located around the site. The majority of the concrete sidewalk is in good condition. Approximately 10% of the sidewalk has cracks that may require replacement in the future. Most of this cracked walk is primarily on the southeast side of the building around the information kiosk.



IV. SUMMARY

The Tilford Westbound Rest Area is located along Interstate 90, approximately 16 miles north and west of the Rapid City, South Dakota metropolitan area. The rest area has direct access from Interstate 90 and provides one centralized parking lot for both passenger vehicles and trucks visiting the site.

The purpose of this report was to summarize the condition of existing site components and building systems for the facility as a whole, and to define the general status of the existing facilities given their age and use.

As the main building structure was constructed in 1973, the general building systems as a whole are nearing the end of their design life. There will be an increasing need ahead for repairs and reconstruction including system upgrades to the mechanical, power and lighting systems.

This site is fairly narrow and long, which would allow for the expansion of the facility in the future. The grade challenges limit ease of access to facility for the elderly and handicapped, which will need to be addressed. Most importantly, the smell from the septic ponds are often substantial and discourage use at the facility, and the picnic areas. There are also some improvements and repairs that will be needed in the near future.

The facility will need to be modified to comply with ADA/building code requirements. The extent of which has yet to be determined, as an additional factor will be in identifying the added space required to modify the restroom entrances, to support increased user loads (if any), and to provide family assist restroom(s).



The Interstate Rest Areas Study: Along the I-29 and I-90 Corridors

APPENDIX A MAINTENANCE STAFF MEETING MINUTES



October 15, 2013

MEETING MINUTES

SDDOT INTERSTATE REST AREA STUDY

FHU Reference No. 113039-01

Tilford Westbound Maintenance Review Meeting

Tilford Westbound Rest Area

Date of Meeting: September 19, 2013

In attendance:

- Brad Remmich – SDDOT
- Dan Cooper – SDDOT
- Tim Roach – TSP
- Steve Tebben – TSP
- Todd Schultz - TSP

The purpose of the meeting was to gain initial insights from the SDDOT maintenance team about the operation, history, and condition of the existing on-site facilities at the Tilford Westbound rest area. The following summarizes the key points of the meeting:

FACILITY USE

- The facilities are used consistently year round by truckers and local commuters with no substantial slow periods. In the summer months, there is a notable increase in tourists (many in campers) which peaks during the Sturgis Rally. There are times during this Rally week that the facility is overflowing with insufficient parking, restrooms stalls, and lobby space.
- Based on SDDOT information, with the exception of the Sturgis Rally, the facility seems to be sized appropriately for all user groups, and has sufficient stalls for auto, camper, and truck parking. There is only a limited need for the picnic shelters – only about ½ of the units are used most of the times.
- The facility houses a full time manned tourist center during the summer months (roughly from May to August). This center was not staffed or open at the time of the meeting; however we understand that there is insufficient space for the displays, and for short and long-term storage. Currently long-term storage of travel documents are placed in the maintenance rooms, and in an outside portable shed (approx. 12'x 12').
- The facility gets a higher percentage of male users for the restrooms (perhaps truckers).

USER INFORMATION

- Truckers use this site heavily as the closest next stop to the west is about 130 miles towards Gillette. Many will stop overnight at the site. Many commuters also use the facility year round traveling between Spearfish and Rapid City.
- There is a higher proportion of tourists with campers at this location – it's should be noted that the dump station is highly utilized by this group and appears to be a worthwhile service. Also, Dan Cooper (SDDOT) has developed a lid system for the tank which limits the ability of the user to dump undesirable items and garbage which clogs up the system.

FACILITY NEEDS / ISSUES

- There is no history of formal complaints from users at this location.
- ADA parking is provided in a separate lot at the side/rear of the facility with two parking spaces. Many travelers don't realize that this ADA parking area is available, and usually try to access the building from the main lot. The ADA parking spaces are limited to two. If the lot is full, there is no way back to the main lot by auto.
- The facility is located at the western end of the general parking lot (rather than centrally located). The parking lot at that point is roughly 5' higher than the building entrance. Access to the building from the main parking lot is provided by a ramp (non-ADA).
- A very noticeable septic smell was emanating from the lagoon system. The facility has lagoons to the north and south of the structure (one supports the lagoons for the Tilford East facility). Apparently, the chemicals used by the campers from the dump stations kill the needed bacteria in the lagoons. This is counteracted by additional bacteria provided by the maintenance crew. This issue should be further reviewed as the smell at the site was highly noticeable.
- The tourism information screen in the lobby is ineffectively slow as it works on standard phone modem connection. The facility needs internet access for this device to be effective.
- There were no immediate safety or security issues reported. A video monitor system is very successful in reducing vandalism and security problems.
- There is no known history of accidents related to current facility and on site circulation.
- Site Systems (landscaping, lighting, trash, ponds, etc.):
 - Sidewalk, stairs, and paving show signs of aging and wear.
 - Lagoon System and Lift Station are well maintained and have no history of a major overhaul to date.
 - New fiberglass water tank has been installed (at Tilford East) about 10-12 years ago for the well water system, which supports both the East and West facilities.
 - Lawn Sprinkler system works well.
 - Site parking, pedestrian, and exterior building lighting systems were replaced "a few years ago".
- Building Systems (shell, interior finishes, MEP):
 - Building has been partially modified to meet ADA in the 1990's
 - Interior Lighting outdated and failing – maintenance cost and problems.
 - General building power is three phase power system - equipment is old and may need modernization/replacement for parts.

October 15, 2013

Tilford Westbound Maintenance Review Meeting

Page 3

- Mechanical systems are very outdated and will eventually need replacement. Bathroom ventilation is set to 15 minute exhaust venting/hr., probably to save energy, but is insufficient, as smell is noticeable.
- Propane fired furnace was replaced a few years ago (heat pump system).
- Security grill at tourist area is old and repair parts are hard to find.

SDDOT MAINTENANCE STAFF REQUESTS

- Facility is lacking in much needed storage and display space for the tourist information area.
- Information Space is undersized, with little room for visitors and displays -the available area is noticeably cramped. No storage space provided for in original design.
- Counters not ADA compliant and have insufficient clearances.
- Rear access door to maintenance rooms too narrow (not ADA).
- Sliding Gate needs replacement.

These meeting minutes were prepared by Tim Roach (TSP). Please contact me at roachtj@teamtsp.com or 605-343-6102 for corrections or clarifications.



The Interstate Rest Areas Study: Along the I-29 and I-90 Corridors

APPENDIX B ADA SURVEY RESULTS

SDDOT Rest Area Improvements
FHU Reference Number 13-039-01
TSP Project Number 03120855

Building	TILFORD WEST
Location	90 W., MRM 41
Date	09-19-2013 (Inspection)

ADA Checklist for Readily Achievable Barrier Removal

Priority 1 – Approach & Entrance



SDDOT Rest Area Improvements

FHU Reference Number 13-039-01

TSP Project Number 03120855

Project

Building

TILFORD WEST

Location

90 W., MRM 41

Date

09-19-2013 (Inspection)

Surveyors

Timothy Roach, AIA

Todd Schultz, PE

Contact Information

TSP – (605) 343-6102

An accessible route from site arrival points and an accessible entrance should be provided for everyone.



Institute for Human Centered Design

www.HumanCenteredDesign.org

November 2011



ADA National Network

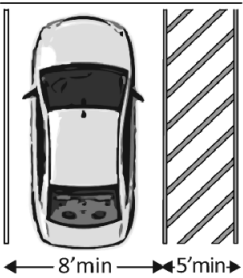
Questions on the ADA 800-949-4232 voice/tty

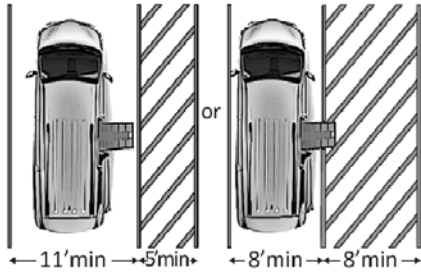
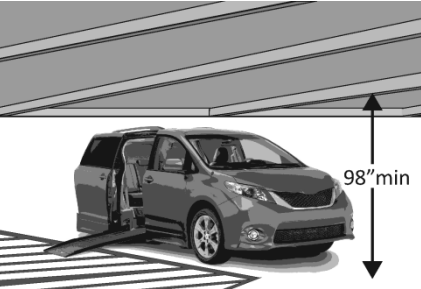
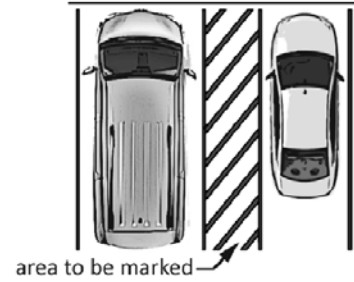
www.ADAchecklist.org


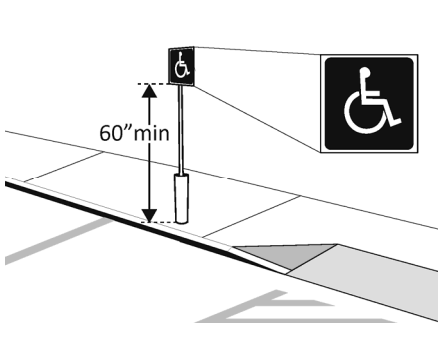
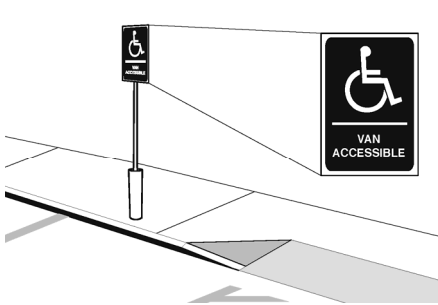
This checklist was produced by the New England ADA Center, a project of the Institute for Human Centered Design and a member of the ADA National Network. This checklist was developed under a grant from the Department of Education, NIDRR grant number H133A060092-09A. However the contents do not necessarily represent the policy of the Department of Education, and you should not assume endorsement by the Federal Government.

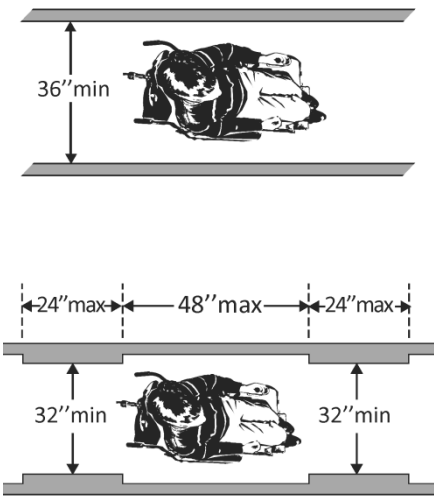
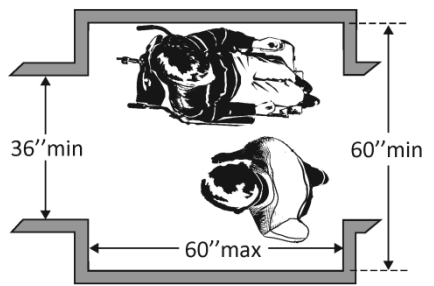
Questions or comments on the checklist contact the New England ADA Center at 617-695-0085 voice/tty or ADAinfo@NewEnglandADA.org

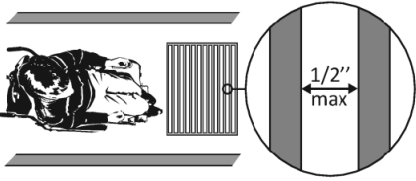
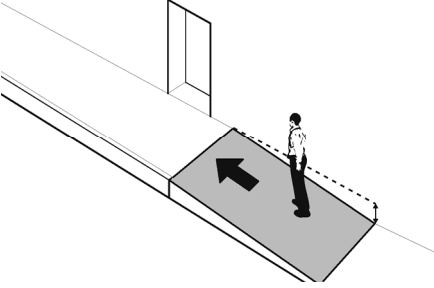
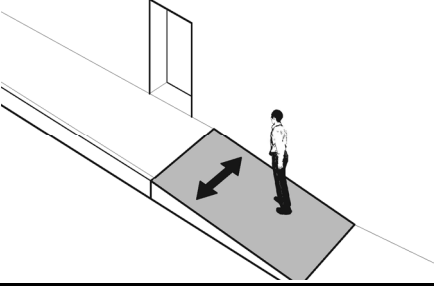
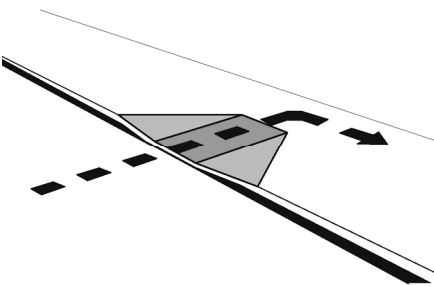
For the full set of checklists, including the checklists for recreation facilities visit www.ADAchecklist.org.

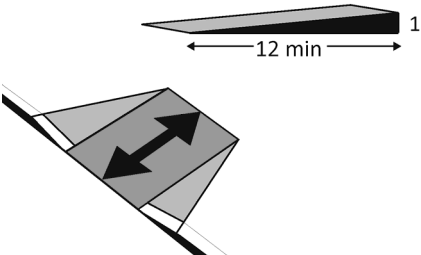
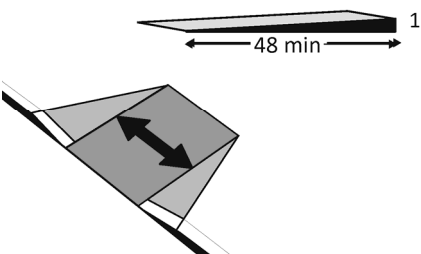
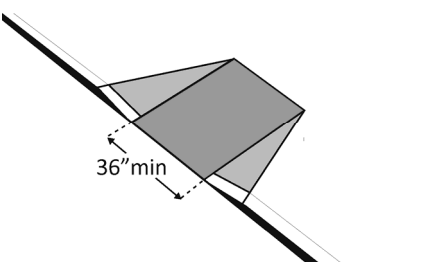
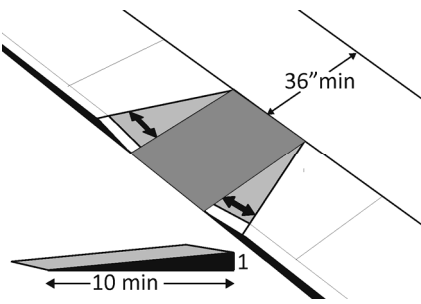
Priority 1 – Approach & Entrance		Comments	Possible Solutions												
<p>1.1 Is there at least one route from site arrival points (parking, passenger loading zones, public sidewalks and public transportation stops) that does not require the use of stairs?</p>	<p><input checked="" type="checkbox"/> Yes <input type="checkbox"/> No</p> <p>If yes, location of route:</p>	<p>From left/rear side of building to front door</p> <p>Photo #: 25</p>	<ul style="list-style-type: none"> • Add a ramp • Regrade to 1:20 maximum slope • Add a lift if site constraints prevent other solutions 												
<p>Parking (2010 Standards – 208 & 502) Note: Accessible parking spaces should be identified by size, access aisle and signage.</p>															
<p>1.2 If parking is provided for the public, are an adequate number of accessible spaces provided?</p>	<p><input checked="" type="checkbox"/> Yes <input type="checkbox"/> No</p> <p>Total #: 14</p> <p>Accessible #: 2</p>	<table border="1"> <thead> <tr> <th>Total Spaces</th> <th>Accessible Spaces</th> </tr> </thead> <tbody> <tr> <td>1 - 25</td> <td>1</td> </tr> <tr> <td>26 - 50</td> <td>2</td> </tr> <tr> <td>51 - 75</td> <td>3</td> </tr> <tr> <td>76 - 100</td> <td>4</td> </tr> <tr> <td colspan="2">100+ see 2010 Standards 208.2</td> </tr> </tbody> </table> <p>Photo #: C0125</p>	Total Spaces	Accessible Spaces	1 - 25	1	26 - 50	2	51 - 75	3	76 - 100	4	100+ see 2010 Standards 208.2		<ul style="list-style-type: none"> • Reconfigure by repainting lines • •
Total Spaces	Accessible Spaces														
1 - 25	1														
26 - 50	2														
51 - 75	3														
76 - 100	4														
100+ see 2010 Standards 208.2															
<p>1.3 Of the accessible spaces, is at least one a van accessible space?*</p>	<p><input checked="" type="checkbox"/> Yes <input type="checkbox"/> No</p>	<p>*For every 6 or fraction of 6 parking spaces required by the table above, at least 1 should be a van accessible space.</p> <p>Photo #: C0125</p>	<p>* If constructed before 3/15/2012, parking is compliant if at least 1 in every 8 accessible spaces is van accessible</p> <ul style="list-style-type: none"> • Reconfigure by repainting lines 												
<p>1.4 Are accessible spaces at least 8 feet wide with an access aisle at least 5 feet wide?</p>	<p><input checked="" type="checkbox"/> Yes <input type="checkbox"/> No</p> <p>Measurement:</p>	 <p>8' min 5' min</p> <p>8 ft Parking 8 ft Accessible Aisle</p> <p>Photo #: C0125</p>	<ul style="list-style-type: none"> • Reconfigure by repainting lines <p>Two spaces can share an access aisle (check state requirements; some states, such as Connecticut, require an access aisle for each space)</p>												

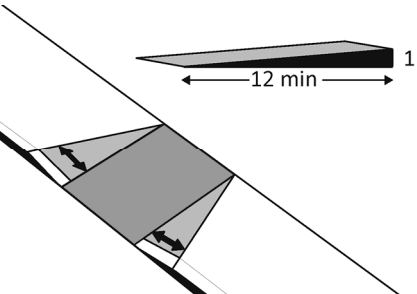
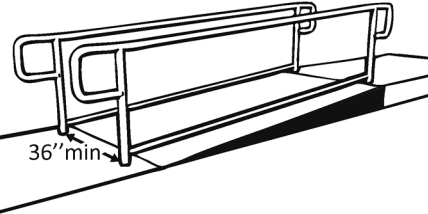
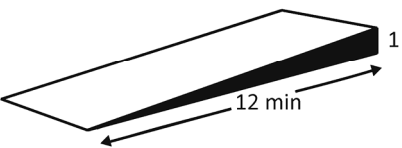
<p>1.5 Is the van accessible space: At least 11 feet wide with an access aisle at least 5 feet wide? Or At least 8 feet wide with an access aisle at least 8 feet wide?</p>	<p><input type="checkbox"/> Yes <input checked="" type="checkbox"/> No Measurement: <input checked="" type="checkbox"/> Yes <input type="checkbox"/> No Measurement:</p>		<p>8 ft wide with access aisle 8 ft. Photo #: C0125</p>	<ul style="list-style-type: none"> • Reconfigure to provide van-accessible space(s) • •
<p>1.6 Is at least 98 inches of vertical clearance provided for the van accessible space?</p>	<p><input type="checkbox"/> Yes <input type="checkbox"/> No Measurement:</p>		<p>Photo #: C0125</p>	<ul style="list-style-type: none"> • Reconfigure to provide van-accessible space(s) • •
<p>1.7 Are the access aisles marked so as to discourage parking in them?</p>	<p><input checked="" type="checkbox"/> Yes <input type="checkbox"/> No</p>		<p>Photo #: C0125</p>	<ul style="list-style-type: none"> • Mark access aisles • • <p>The marking method and color may be addressed by state/local requirements</p>
<p>1.8 Is the slope of the accessible parking spaces and access aisles no steeper than 1:48 in all directions?</p>	<p><input type="checkbox"/> Yes <input checked="" type="checkbox"/> No Measurement: 1:20</p>		<p>Photo #: C0123</p>	<ul style="list-style-type: none"> • Regrade surface • •

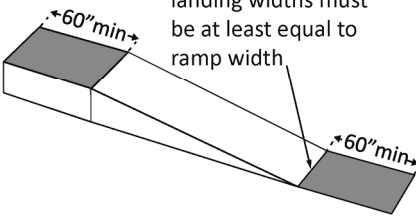
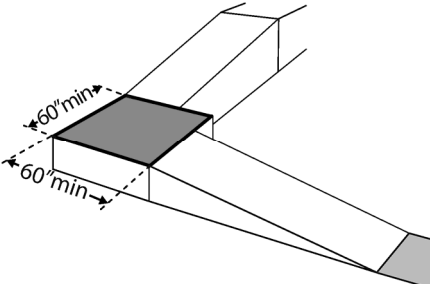
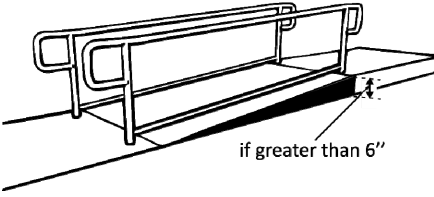
<p>1.9 Do the access aisles adjoin an accessible route?</p>	<p><input checked="" type="checkbox"/> Yes <input type="checkbox"/> No</p>		<p>Photo #: 25</p>	<ul style="list-style-type: none"> • Create accessible route • Relocate accessible space •
<p>1.10 Are accessible spaces Identified with a sign that includes the International Symbol of Accessibility?</p> <p>Is the bottom of the sign at least 60 inches above the ground?</p>	<p><input type="checkbox"/> Yes <input checked="" type="checkbox"/> No</p> <p><input checked="" type="checkbox"/> Yes <input type="checkbox"/> No</p> <p>Measurement:</p>		<p>• Need signs for both spaces</p> <p>• One sign is between both spaces</p> <p>Photo #: C0125</p>	<ul style="list-style-type: none"> • Install signs • • <p>The International Symbol of Accessibility is not required on the ground by the 2010 Standards</p>
<p>1.11 Are there signs reading “van accessible” at van accessible spaces?</p>	<p><input checked="" type="checkbox"/> Yes <input type="checkbox"/> No</p>		<p>Photo #: C0125</p>	<ul style="list-style-type: none"> • Install signs • •
<p>1.12 Of the total parking spaces, are the accessible spaces located on the closest accessible route to the accessible entrance(s)?</p>	<p><input checked="" type="checkbox"/> Yes <input type="checkbox"/> No</p>		<p>Photo #: 25</p>	<ul style="list-style-type: none"> • Reconfigure spaces • • <p>If parking lot serves multiple entrances, accessible parking should be dispersed</p>

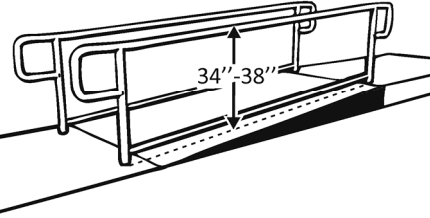
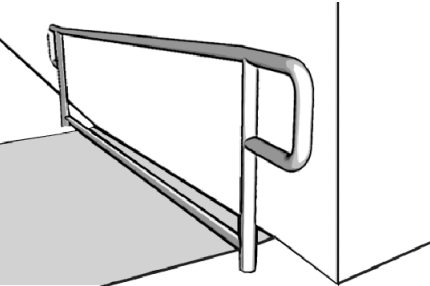
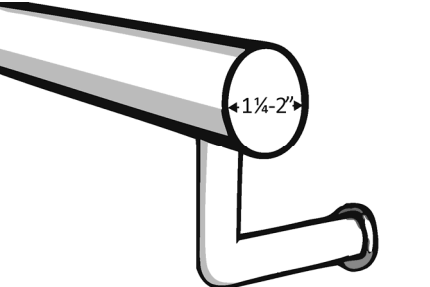
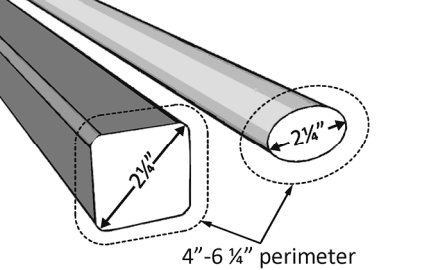
Exterior Accessible Route (2010 Standards – Ch.4)				
<p>1.13 Is the route stable, firm and slip-resistant?</p>	<p><input type="checkbox"/> Yes <input type="checkbox"/> No</p>		<p>Photo #:</p>	<ul style="list-style-type: none"> • Repair uneven paving • Fill small bumps and breaks with patches • Replace gravel with asphalt or other surface
<p>1.14 Is the route at least 36 inches wide?</p> <p>Note: The accessible route can narrow to 32 inches min. for a max. of 24 inches. These narrower portions of the route must be at least 48 inches from each other.</p>	<p><input type="checkbox"/> Yes <input type="checkbox"/> No</p> <p>Measurement:</p>	 <p>The diagram illustrates two scenarios for route width. The top scenario shows a wheelchair on a path that is at least 36 inches wide. The bottom scenario shows a wheelchair on a path that is at least 32 inches wide, with narrow sections of 24 inches maximum width. These narrow sections must be separated by a distance of at least 48 inches.</p>	<p>Photo #:</p>	<ul style="list-style-type: none"> • Change or move landscaping, furnishings or other items • Widen route •
<p>1.15 If the route is greater than 200 feet in length and no less than 60 inches wide, is there a passing space no less than 60 x 60 inches?</p>	<p><input type="checkbox"/> Yes <input type="checkbox"/> No</p> <p>Measurement:</p>	 <p>The diagram shows a passing space for two wheelchairs. The space is at least 60 inches wide and 60 inches deep. The wheelchairs are shown positioned such that they do not overlap, with a minimum clearance of 36 inches between them.</p>	<p>Photo #:</p>	<ul style="list-style-type: none"> • Widen route for passing space • •

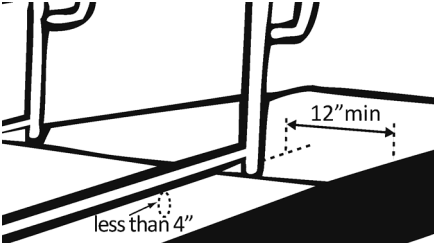
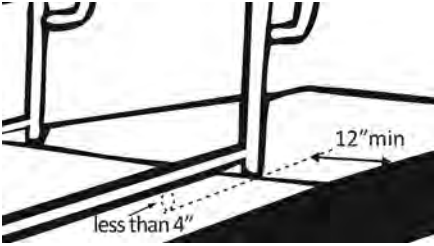
<p>1.16 If there are grates or openings on the route, are the openings no larger than ½ inches to the dominant direction of travel?</p> <p>Is the long dimension perpendicular to the dominant direction of travel?</p>	<p><input type="checkbox"/> Yes <input type="checkbox"/> No</p> <p>Measurement:</p> <p><input type="checkbox"/> Yes <input type="checkbox"/> No</p>		<p>Photo #:</p>	<ul style="list-style-type: none"> • Replace or move grate • •
<p>1.17 Is the running slope no steeper than 1:20, i.e. for every inch of height change there are at least 20 inches of route run?</p>	<p><input type="checkbox"/> Yes <input type="checkbox"/> No</p> <p>Measurement:</p>		<p>Photo #:</p>	<ul style="list-style-type: none"> • Regrade to 1:20 max. • If steeper than 1:20 and no steeper than 1:12, treat as a ramp and add other features such as edge protection and handrails •
<p>1.18 Is the cross slope no steeper than 1:48?</p>	<p><input type="checkbox"/> Yes <input type="checkbox"/> No</p> <p>Measurement:</p>		<p>Photo #:</p>	<ul style="list-style-type: none"> • Regrade to 1:48 max. • •
<p>Curb Ramps (2010 Standards – 406)</p>				
<p>1.19 If the accessible route crosses a curb, is there a curb ramp?</p>	<p><input type="checkbox"/> Yes <input type="checkbox"/> No</p>		<p>Photo #:</p>	<ul style="list-style-type: none"> • Install curb ramp • •


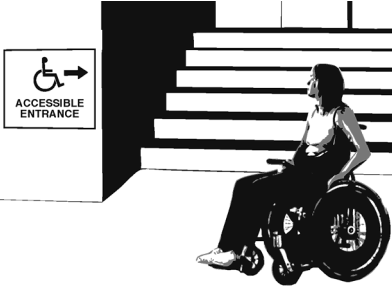

<p>1.20 Is the running slope of the curb ramp no steeper than 1:12, i.e. for every inch of height change there are at least 12 inches of curb ramp run?</p>	<p><input type="checkbox"/> Yes <input type="checkbox"/> No</p> <p>Measurement:</p>		<p>Photo #:</p>	<ul style="list-style-type: none"> • Regrade curb ramp • •
<p>1.21 Is the cross slope of the curb ramp, excluding flares, no steeper than 1:48?</p>	<p><input type="checkbox"/> Yes <input type="checkbox"/> No</p> <p>Measurement:</p>		<p>Photo #:</p>	<ul style="list-style-type: none"> • Regrade curb ramp • •
<p>1.22 Is the curb ramp, excluding flares, at least 36 inches wide?</p>	<p><input type="checkbox"/> Yes <input type="checkbox"/> No</p> <p>Measurement:</p>		<p>Photo #:</p>	<ul style="list-style-type: none"> • Widen curb ramp • •
<p>1.23 At the top of the curb ramp is there a level landing (slope no steeper than 1:48 in all directions) that is at least 36 inches long and at least as wide as the curb ramp?</p> <p>If there are curb ramp flares, are the slopes of the flares no steeper than 1:10, i.e. for every inch of height change there are</p>	<p><input type="checkbox"/> Yes <input type="checkbox"/> No</p> <p>Measurement:</p> <p><input type="checkbox"/> Yes <input type="checkbox"/> No</p> <p>Measurement:</p>		<p>Photo #:</p>	<ul style="list-style-type: none"> • Reconfigure • Add ramp flares •

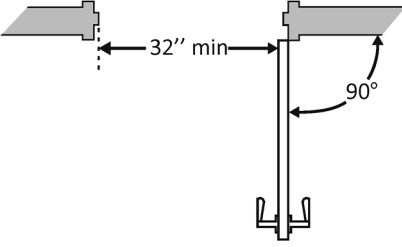
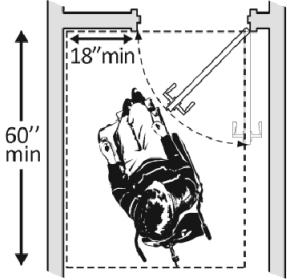
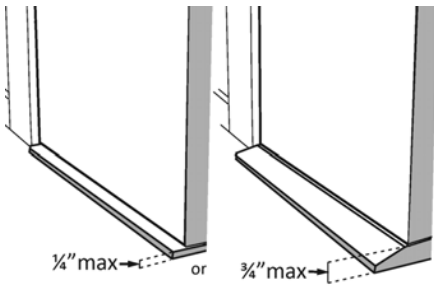
<p>at least 10 inches of flare run?</p>			<p>Photo #:</p>	
<p>1.24 If the landing at the top is less than 36 inches long, are there curb ramp flares?</p> <p>Are the slopes of the flares no greater than 1:12, i.e. for every inch of height change there are at least 12 inches of flare run?</p>	<p><input type="checkbox"/> Yes <input type="checkbox"/> No</p> <p><input type="checkbox"/> Yes <input type="checkbox"/> No</p> <p>Measurement:</p>		<p>Photo #:</p>	<ul style="list-style-type: none"> • Add ramp flares • Regrade flares •
<p>Ramps (2010 Standards – 405 & 505) Note: If any portion of the accessible route is steeper than 1:20, it should be treated as a ramp.</p>				
<p>1.25 If there is a ramp (other than curb ramps), is it at least 36 inches wide? If there are handrails, measure between the handrails.</p>	<p><input type="checkbox"/> Yes <input type="checkbox"/> No</p> <p>Measurement:</p>		<p>Photo #:</p>	<ul style="list-style-type: none"> • Alter ramp • •
<p>1.26 Is the surface stable, firm and slip resistant?</p>	<p><input type="checkbox"/> Yes <input type="checkbox"/> No</p>		<p>Photo #:</p>	<ul style="list-style-type: none"> • Resurface ramp • •
<p>1.27 For each section of the ramp, is the running slope no greater than 1:12, i.e. for every inch of height change there are at least 12 inches of ramp run?</p> <p>Note: Rises no greater than 3 inches with a slope no steeper than</p>	<p><input type="checkbox"/> Yes <input type="checkbox"/> No</p> <p>Measurement:</p>		<p>Photo #:</p>	<ul style="list-style-type: none"> • Alter or relocate ramp • Lengthen ramp to decrease slope •

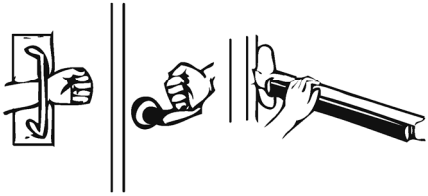
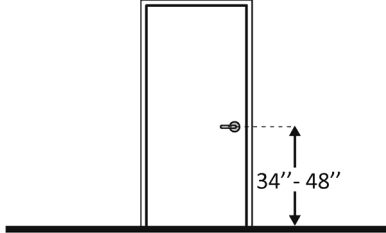
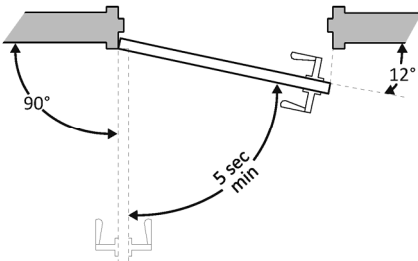
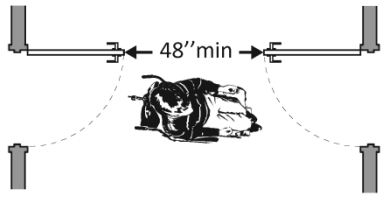

<p>1:8 and rises no greater than 6 inches with a slope no steeper than 1:10 are permitted when such slopes are necessary due to space limitations.</p>			<p>Photo #:</p>	
<p>1.28 Is there a level landing that is at least 60 inches long and at least as wide as the ramp:</p> <p>At the top of the ramp?</p> <p>At the bottom of the ramp?</p>	<p><input type="checkbox"/> Yes <input type="checkbox"/> No</p> <p>Measurement:</p> <p><input type="checkbox"/> Yes <input type="checkbox"/> No</p> <p>Measurement:</p>		<p>Photo #:</p>	<ul style="list-style-type: none"> • Alter ramp • •
<p>1.29 Is there a level landing where the ramp changes direction that is at least 60 x 60 inches?</p>	<p><input type="checkbox"/> Yes <input type="checkbox"/> No</p> <p>Measurement:</p>		<p>Photo #:</p>	<ul style="list-style-type: none"> • Alter ramp • •
<p>1.30 If the ramp has a rise higher than 6 inches, are there handrails on both sides?</p>	<p><input type="checkbox"/> Yes <input type="checkbox"/> No</p> <p>Measurement:</p>		<p>Photo #:</p>	<ul style="list-style-type: none"> • Add handrails • • <p>Curb ramps are not required to have handrails</p>

<p>1.31 Is the top of the handrail gripping surface no less than 34 inches and no greater than 38 inches above the ramp surface?</p>	<p><input type="checkbox"/> Yes <input checked="" type="checkbox"/> No</p> <p>Measurement:</p> <p>32"</p>		<p>Photo #: 7</p>	<ul style="list-style-type: none"> • Reconfigure or replace handrails • •
<p>1.32 Is the handrail gripping surface continuous and not obstructed along the top or sides?</p> <p>Is the bottom of the handrail gripping surface obstructed for no more than 20 percent of its length?</p>	<p><input checked="" type="checkbox"/> Yes <input type="checkbox"/> No</p> <p><input type="checkbox"/> Yes <input checked="" type="checkbox"/> No</p> <p>Measurement:</p>		<p>Photo #: 14</p>	<ul style="list-style-type: none"> • Reconfigure or replace handrails • •
<p>1.33 If the handrail gripping surface is circular, is it no less than 1 ¼ inches and no greater than 2 inches in diameter?</p>	<p><input type="checkbox"/> Yes <input type="checkbox"/> No</p> <p>Measurement:</p>		<p>Photo #:</p>	<ul style="list-style-type: none"> • Replace handrails • •
<p>1.34 If the handrail gripping surface is non-circular, is it no less than 4 inches and no greater than 6 ½ inches in perimeter and no more than 2 ¼ inches in cross section?</p>	<p><input type="checkbox"/> Yes <input type="checkbox"/> No</p> <p>Measurement:</p>		<p>Photo #:</p>	<ul style="list-style-type: none"> • Replace handrails • •

<p>1.35 Does the handrail:</p> <p>Extend at least 12 inches horizontally beyond the top and bottom of the ramp?</p> <p>Return to a wall, guard, or landing surface?</p>	<p><input type="checkbox"/> Yes <input checked="" type="checkbox"/> No</p> <p>Measurement:</p> <p><input type="checkbox"/> Yes <input checked="" type="checkbox"/> No</p>		<p>Photo #: 8</p>	<ul style="list-style-type: none"> • Add extensions • Reconfigure handrails •
<p>1.36 To prevent wheelchair casters and crutch tips from falling off:</p> <p>Does the surface of the ramp extend at least 12 inches beyond the inside face of the handrail?</p> <p>Or</p> <p>Is there a curb or barrier that prevents the passage of a 4-inch diameter sphere?</p>	<p><input type="checkbox"/> Yes <input checked="" type="checkbox"/> No</p> <p>Measurement:</p> <p><input type="checkbox"/> Yes <input checked="" type="checkbox"/> No</p>		<p>Photo #: 8</p>	<ul style="list-style-type: none"> • Add curb • Add barrier • Extend ramp width •
<p>Entrance (2010 Standards – 404)</p>				
<p>1.37 Is the main entrance accessible?</p>	<p><input type="checkbox"/> Yes <input checked="" type="checkbox"/> No</p>		<p>• ACCESSIBLE FROM PARKING.</p> <p>• Needs slope correction.</p> <p>• Limited to 2 spaces, could expand.</p> <p>• Entry Door modifications model</p> <p>Photo #: 25</p>	<ul style="list-style-type: none"> • Redesign to make it accessible • •

<p>1.38 If the main entrance is not accessible, is there an alternative accessible entrance?</p> <p>Can the alternative accessible entrance be used independently and during the same hours as the main entrance?</p>	<p><input type="checkbox"/> Yes <input checked="" type="checkbox"/> No</p> <p><input type="checkbox"/> Yes <input type="checkbox"/> No</p>		<p>• NO ALTERNATE ENTRANCE</p> <p>Photo #:</p>	<ul style="list-style-type: none"> • Designate an entrance and make it accessible • Ensure that accessible entrance can be used independently and during the same hours as the main entrance •
<p>1.39 Do all inaccessible entrances have signs indicating the location of the nearest accessible entrance?</p>	<p><input type="checkbox"/> Yes <input type="checkbox"/> No</p>		<p>NA</p> <p>Photo #:</p>	<ul style="list-style-type: none"> • Install signs • Install signs on route before people get to inaccessible entrances so that people do not have to turn around and retrace route •
<p>1.40 If not all entrances are accessible, is there a sign at the accessible entrance with the International Symbol of Accessibility?</p>	<p><input type="checkbox"/> Yes <input type="checkbox"/> No</p>		<p>NA</p> <p>Photo #:</p>	<ul style="list-style-type: none"> • Install sign • •

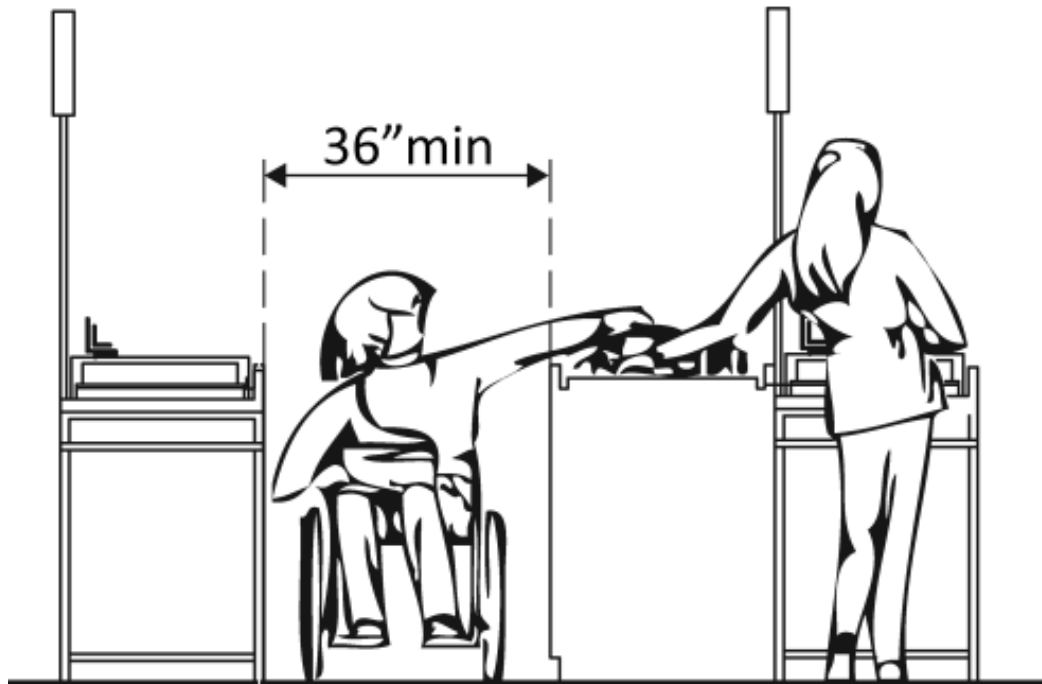
<p>1.41 Is the clear opening width of the accessible entrance door at least 32 inches, between the face of the door and the stop, when the door is open 90 degrees?</p>	<p><input checked="" type="checkbox"/> Yes <input type="checkbox"/> No</p> <p>Measurement:</p> <p>32"</p>		<p>Photo #: 19</p>	<ul style="list-style-type: none"> • Alter door • Install offset hinges •
<p>1.42 If there is a front approach to the pull side of the door, is there at least 18 inches of maneuvering clearance beyond the latch side plus at least 60 inches clear depth?</p> <p>On both sides of the door, is the ground or floor surface of the maneuvering clearance level (no steeper than 1:48)?</p>	<p><input checked="" type="checkbox"/> Yes <input type="checkbox"/> No</p> <p>Measurement:</p> <p>NA</p> <p><input checked="" type="checkbox"/> Yes <input type="checkbox"/> No</p> <p>Measurement:</p> <p>NA</p>		<p>Photo #: 21</p>	<p>See 2010 Standards 404.2.4 for maneuvering clearance requirements on the push side of the door and side approaches to the pull side of the door</p> <ul style="list-style-type: none"> • Remove obstructions • Reconfigure walls • Add automatic door opener
<p>1.43 Is the door threshold edge no more than ¼ inch high?</p> <p>Or</p> <p>No more than ¾ inch high if slope is beveled no steeper than 1:2?</p> <p>Note: The first ¼ inch of the threshold may be vertical; the rest must be beveled.</p>	<p><input type="checkbox"/> Yes <input type="checkbox"/> No</p> <p>Measurement:</p> <p><input type="checkbox"/> Yes <input type="checkbox"/> No</p> <p>Measurement:</p> <p>< ¾"</p>		<p>Photo #: 22</p>	<ul style="list-style-type: none"> • Remove or replace threshold • •

<p>1.44 Is the door equipped with hardware, including locks, that is operable with one hand and does not require tight grasping, pinching, or twisting of the wrist?</p>	<p><input type="checkbox"/> Yes <input checked="" type="checkbox"/> No</p>		<p>Photo #: 26</p>	<ul style="list-style-type: none"> • Replace inaccessible knob with lever, loop or push hardware • Add automatic door opener •
<p>1.45 Are the operable parts of the door hardware no less than 34 inches and no greater than 48 inches above the floor or ground surface?</p>	<p><input type="checkbox"/> Yes <input type="checkbox"/> No</p> <p>Measurement:</p>		<p>44" TO CENTER LINE</p> <p>Photo #: 28</p>	<ul style="list-style-type: none"> • Change hardware height • •
<p>1.46 If the door has a closer, does it take at least 5 seconds to close from an open position of 90 degrees to a position of 12 degrees from the latch?</p>	<p><input type="checkbox"/> Yes <input checked="" type="checkbox"/> No</p> <p>Measurement:</p> <p>2 ½ SECONDS</p>		<p>Photo #: 29</p>	<ul style="list-style-type: none"> • Adjust closer • •
<p>1.47 If there are two doors in a series, e.g. vestibule, is the distance between the doors at least 48 inches plus the width of the doors when swinging into the space?</p>	<p><input type="checkbox"/> Yes <input type="checkbox"/> No</p> <p>Measurement:</p>	 <p>or</p> 	<p>NA</p>	<ul style="list-style-type: none"> • Remove inner door • Change door swing •

		<p style="text-align: center;">48" min</p> <p style="text-align: center;">or</p> <p style="text-align: center;">48" min</p>	<p>Photo #: 30</p>	
<p>1.48 If provided at the building entrance, are carpets or mats no higher than ½ inch thick?</p>	<p><input checked="" type="checkbox"/> Yes <input type="checkbox"/> No</p> <p>Measurement:</p>	<p style="text-align: center;">½" max</p>	<p>Photo #: 32</p>	<ul style="list-style-type: none"> • Replace or remove mats • •
<p>1.49 Are edges of carpets or mats securely attached to minimize tripping hazards?</p>	<p><input checked="" type="checkbox"/> Yes <input type="checkbox"/> No</p>		<ul style="list-style-type: none"> • Rubber Board – non slip <p>Photo #: 32</p>	<ul style="list-style-type: none"> • Secure carpeting or mats at edges • •

ADA Checklist for Readily Achievable Barrier Removal

Priority 2 – Access to Goods & Services



Project **SDDOT Rest Area Improvements**
FHU Reference Number 13-039-01
TSP Project Number 03120855

Building **TILFORD WEST**

Location **90 W., MRM 41**

Date **09-19-2013 (Inspection)**

Surveyors **Timothy Roach, AIA**
Todd Schultz, PE

Contact Information **TSP – (605) 343-6102**

The layout of the building should allow people with disabilities to obtain goods and services and to participate in activities without assistance.



Institute for Human Centered Design
www.HumanCenteredDesign.org

November 2011



ADA National Network
Questions on the ADA 800-949-4232 voice/tty

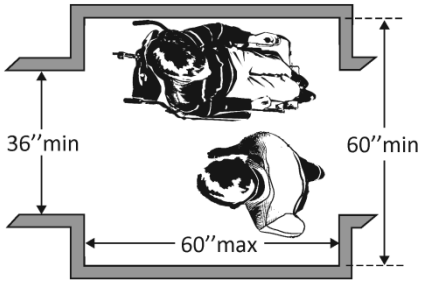
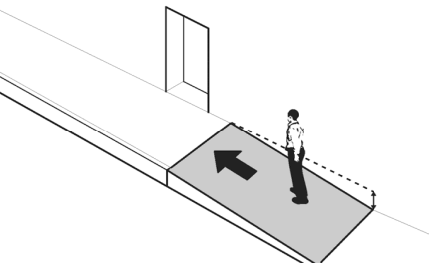
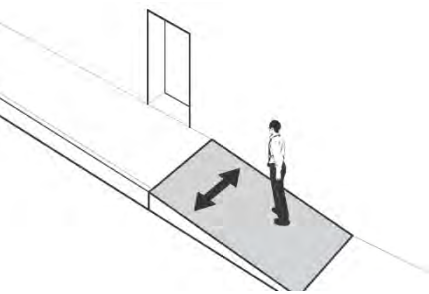

www.ADAchecklist.org

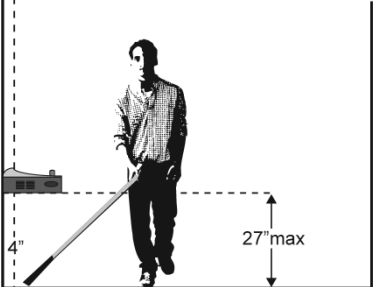
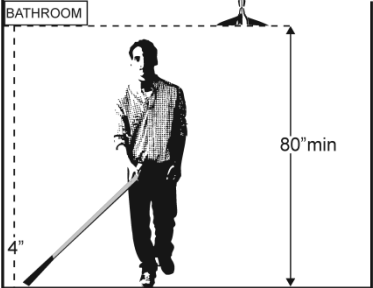
This checklist was produced by the New England ADA Center, a project of the Institute for Human Centered Design and a member of the ADA National Network. This checklist was developed under a grant from the Department of Education, NIDRR grant number H133A060092-09A. However the contents do not necessarily represent the policy of the Department of Education, and you should not assume endorsement by the Federal Government.

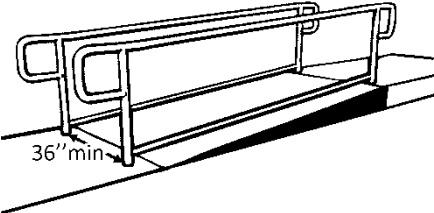

Questions or comments on the checklist contact the New England ADA Center at 617-695-0085 voice/tty or ADAinfo@NewEnglandADA.org

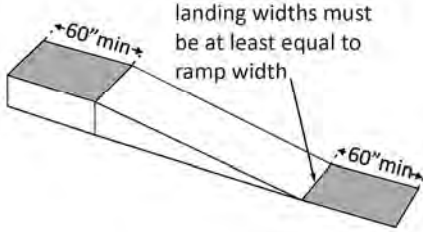
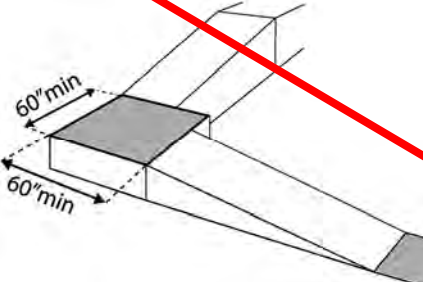
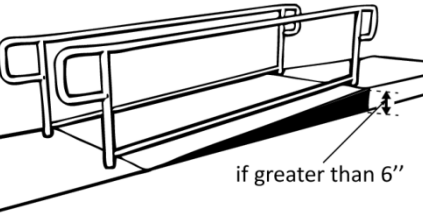
For the full set of checklists, including the checklists for recreation facilities visit www.ADAchecklist.org.

Priority 2 – Access to Goods & Services		Comments	Possible Solutions
<p>2.1 Does the accessible entrance provide direct access to the main floor, lobby and elevator?</p>	<input checked="" type="checkbox"/> Yes <input type="checkbox"/> No	<p>Photo #: 33</p>	<ul style="list-style-type: none"> • Create accessible route • •
Interior Accessible Route (2010 Standards – Ch.4)			
<p>2.2 Are all public spaces on at least one accessible route?</p>	<input checked="" type="checkbox"/> Yes <input type="checkbox"/> No	<p>Photo #: 33</p>	<ul style="list-style-type: none"> • Create accessible route • •
<p>2.3 Is the route stable, firm and slip-resistant?</p>	<input checked="" type="checkbox"/> Yes <input type="checkbox"/> No	<p>Photo #: 35</p>	<ul style="list-style-type: none"> • Repair uneven surfaces • •
<p>2.4 Is the route at least 36 inches wide?</p> <p>Note: The accessible route can narrow to 32 inches min. for a max. of 24 inches. These narrower portions of the route must be at least 48 inches from each other.</p>	<input checked="" type="checkbox"/> Yes <input type="checkbox"/> No	<p>Measurement: Men & Women's 39" + 34" @ Door Jam</p> <p>Photo #: 41 – Men's 40 – Women's</p>	<ul style="list-style-type: none"> • Widen route • •

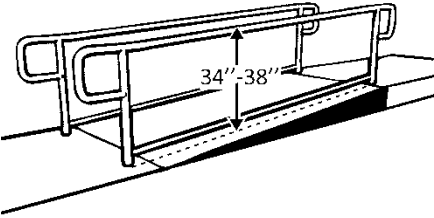
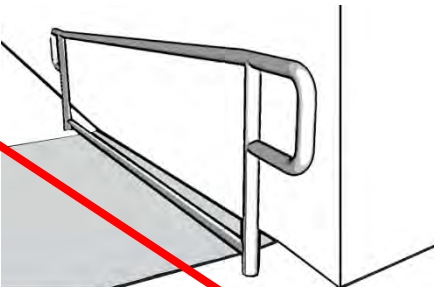
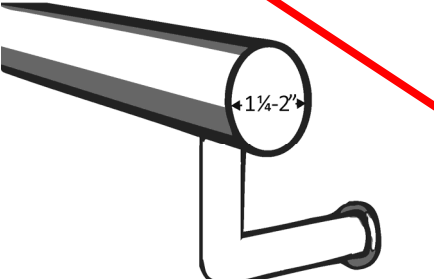
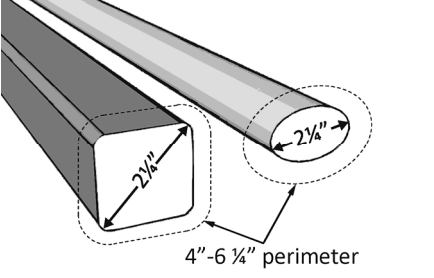
<p>2.5 If the route is greater than 200 feet in length and no less than 36 inches wide, is there a passing space no less than 60 x 60 inches?</p>	<p><input type="checkbox"/> Yes <input checked="" type="checkbox"/> No</p> <p>Measurement:</p>		<p>Photo #:</p> <p style="text-align: center;">NA</p>	<ul style="list-style-type: none"> • Widen route for passing space • •
<p>2.6 Is the running slope no steeper than 1:20, i.e. for every inch of height change there are at least 20 inches of route run?</p>	<p><input type="checkbox"/> Yes <input checked="" type="checkbox"/> No</p> <p>Measurement:</p>		<p>Photo #:</p> <p style="text-align: center;">NA</p>	<ul style="list-style-type: none"> • Regrade • If steeper than 1:20 and no steeper than 1:12, treat as ramp and add other features such as edge protection and handrails •
<p>2.7 Is the cross slope no steeper than 1:48?</p>	<p><input type="checkbox"/> Yes <input checked="" type="checkbox"/> No</p> <p>Measurement:</p>		<p>Photo #:</p> <p style="text-align: center;">NA</p>	<ul style="list-style-type: none"> • Regrade • •
<p>2.8 Do all objects on circulation paths through public areas, e.g. fire extinguishers, drinking fountains, signs, etc., protrude no more than 4 inches into the path? Or If an object protrudes more than 4 inches, is the bottom</p>	<p><input type="checkbox"/> Yes <input checked="" type="checkbox"/> No</p> <p>Measurement:</p> <p><input type="checkbox"/> Yes <input type="checkbox"/> No</p>		<p>Photo #:</p> <p style="text-align: center;">NA</p>	<ul style="list-style-type: none"> • Remove object • Add tactile warning such as permanent planter or partial walls •

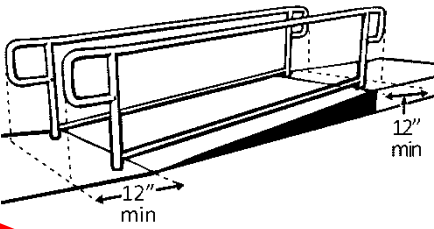
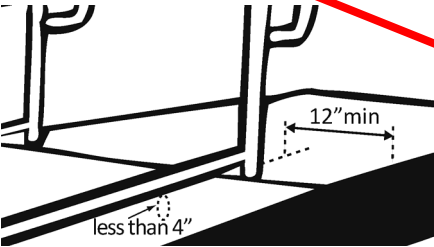
<p>leading edge at 27 inches or lower above the floor? Or Is the bottom leading edge at 80 inches or higher above the floor?</p>	<p>Measurement: <input type="checkbox"/> Yes <input type="checkbox"/> No Measurement:</p>	<p>Or</p>  <p>Or</p> 	<p>Photo #:</p>	
<p>2.9 Are there elevators or platform lifts to all public stories?*</p>	<p><input type="checkbox"/> Yes <input type="checkbox"/> No</p>			<p>*Vertical access is not required in new construction or alterations if a facility is less than three stories or has less than 3,000 square feet per story, unless a facility is a shopping center, shopping mall, professional office of a health care provider, transportation terminal, state facility or</p>

				<p>government facility</p> <ul style="list-style-type: none"> • Install if necessary • Offer goods and services on an accessible story •
Photo #:				
Ramps (2010 Standards 404 & 505)				
<p>2.10 If there is a ramp, is it at least 36 inches wide? If there are handrails, measure between the handrails.</p>	<p><input type="checkbox"/> Yes <input type="checkbox"/> No</p> <p>Measurement:</p>			<ul style="list-style-type: none"> • Alter ramp • •
Photo #:				
<p>2.11 Is the surface stable, firm and slip resistant?</p>	<p><input type="checkbox"/> Yes <input type="checkbox"/> No</p>			<ul style="list-style-type: none"> • Change surface • •
Photo #:				
<p>2.12 For each section of the ramp, is the running slope no greater than 1:12, i.e. for every inch of height change there are at least 12 inches of ramp run?</p> <p>Note: Rises no greater than 3 inches with a slope no steeper than 1:8 and rises no greater than 6 inches with a slope no steeper than 1:10 are permitted when due to space limitations.</p>	<p><input type="checkbox"/> Yes <input type="checkbox"/> No</p> <p>Measurement:</p>			<ul style="list-style-type: none"> • Lengthen ramp to decrease slope • Reconfigure ramp to include switchbacks • Relocate ramp •
Photo #:				

<p>2.13 Is there a level landing that is at least 60 inches long and at least as wide as the ramp:</p> <p>At the top of the ramp?</p> <p>At the bottom of the ramp?</p>	<p><input type="checkbox"/> Yes <input type="checkbox"/> No</p> <p>Measurement:</p> <p><input type="checkbox"/> Yes <input type="checkbox"/> No</p> <p>Measurement:</p>		<p>Photo #:</p>	<ul style="list-style-type: none"> • Alter ramp • Relocate ramp •
<p>2.14 Is there a level landing where the ramp changes direction that is at least 60 x 60 inches?</p>	<p><input type="checkbox"/> Yes <input type="checkbox"/> No</p> <p>Measurement:</p>		<p>Photo #:</p>	<ul style="list-style-type: none"> • Increase landing size • •
<p>2.15 If the ramp has a rise higher than 6 inches are there handrails on both sides?</p>	<p><input type="checkbox"/> Yes <input type="checkbox"/> No</p> <p>Measurement:</p>		<p>Photo #:</p>	<ul style="list-style-type: none"> • Add handrails • •

ADA Checklist for Readily Achievable Barrier Removal **Priority 2 – Access to Goods & Services**

<p>2.16 Is the top of the handrail gripping surface no less than 34 inches and no greater than 38 inches above the ramp surface?</p>	<p><input type="checkbox"/> Yes <input type="checkbox"/> No</p> <p>Measurement:</p>		<p>Photo #:</p>	<ul style="list-style-type: none"> • Adjust handrail height • •
<p>2.17 Is the handrail gripping surface continuous and not obstructed along the top or sides?</p> <p>If there are obstructions, is the bottom of the handrail gripping surface obstructed by no more than 20%?</p>	<p><input type="checkbox"/> Yes <input type="checkbox"/> No</p> <p><input type="checkbox"/> Yes <input type="checkbox"/> No</p> <p>Measurement:</p>		<p>Photo #:</p>	<ul style="list-style-type: none"> • Regrade to 1:20 max • If steeper than 1:20 and no steeper than 1:12, treat as a ramp and add other features such as edge protection and handrails •
<p>2.18 If the handrail gripping surface is circular, is it no less than 1 ¼ inches and no greater than 2 inches in diameter?</p>	<p><input type="checkbox"/> Yes <input type="checkbox"/> No</p> <p>Measurement:</p>		<p>Photo #:</p>	<ul style="list-style-type: none"> • Alter handrails • •
<p>2.19 If the handrail gripping surface is non-circular, is it no less than 4 inches and no greater than 6 ½ inches in perimeter and no more than 2 ¼ inches in cross section?</p>	<p><input type="checkbox"/> Yes <input type="checkbox"/> No</p> <p>Measurement:</p>		<p>Photo #:</p>	<ul style="list-style-type: none"> • Alter handrails • •

<p>2.20 Does the handrail:</p> <p>Extend at least 12 inches beyond the top and bottom of the ramp?</p> <p>Return to a wall, guard, or landing surface?</p>	<p><input type="checkbox"/> Yes <input type="checkbox"/> No</p> <p>Measurement:</p> <p><input type="checkbox"/> Yes <input type="checkbox"/> No</p>		<p>Photo #:</p>	<ul style="list-style-type: none"> • Alter handrails • • <p>If a 12" extension would be hazardous (in circulation path), it is not required</p>
<p>2.21 To prevent wheelchair casters and crutch tips from falling off:</p> <p>Does the surface of the ramp extend at least 12 inches beyond the inside face of the handrail?</p> <p>Or</p> <p>Is there a curb or barrier that prevents the passage of a 4-inch diameter sphere?</p>	<p><input type="checkbox"/> Yes <input type="checkbox"/> No</p> <p>Measurement:</p> <p><input type="checkbox"/> Yes <input type="checkbox"/> No</p> <p>Measurement:</p>		<p>Photo #:</p>	<ul style="list-style-type: none"> • Add curb • Add barrier • Extend ramp width • •

Elevators – Full Size & LULA (limited use, limited application) (2010 Standards – 407 & 408) Note: LULA elevators are often used in alterations.

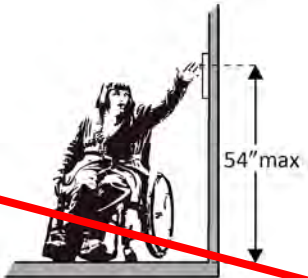
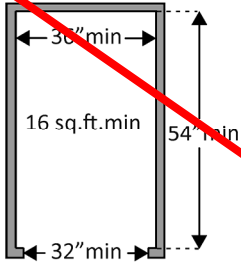
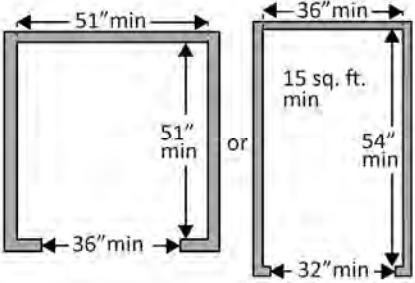
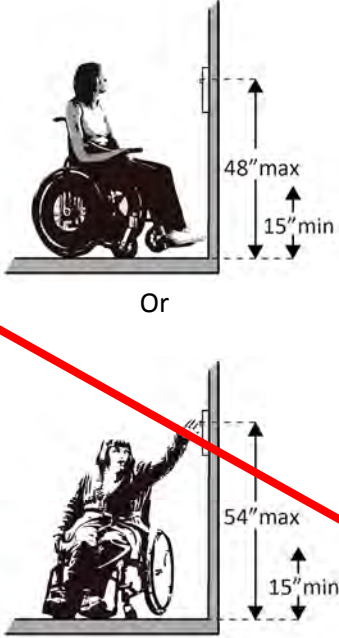

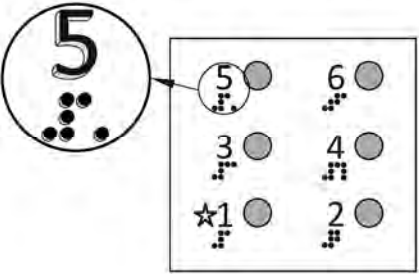
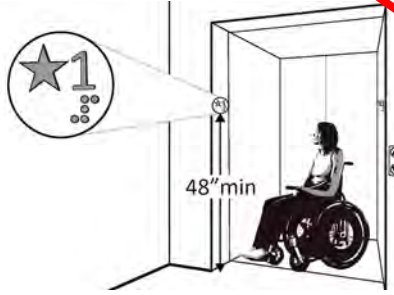

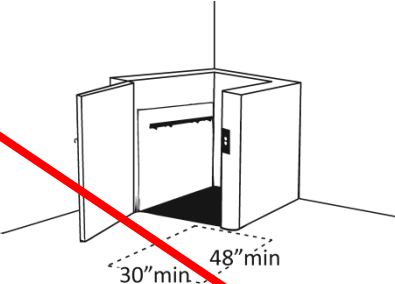
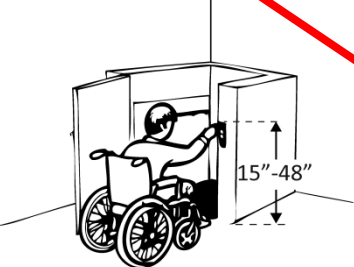
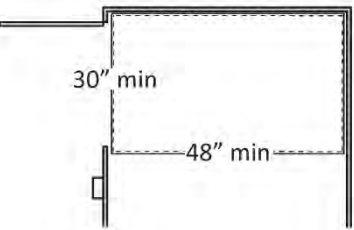
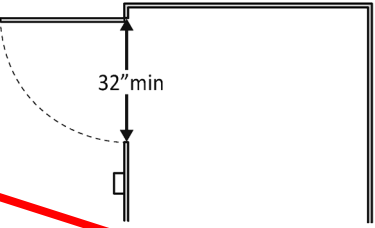
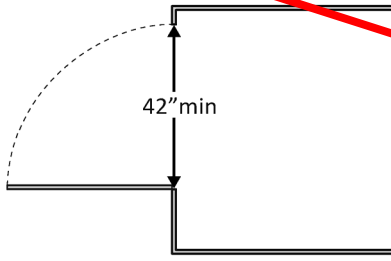
<p>2.22 If there is a full size or LULA elevator, are the call buttons no higher than 54 inches above the floor?</p>	<p><input type="checkbox"/> Yes <input type="checkbox"/> No</p> <p>Measurement:</p>		<p>Photo #:</p>	<ul style="list-style-type: none"> • Change call button height • •
<p>2.23 If there is a full size or LULA elevator, does the sliding door reopen automatically when obstructed by an object or person?*</p>	<p><input type="checkbox"/> Yes <input type="checkbox"/> No</p>			<p>* If constructed before 3/15/2012 and manually operated, the door is not required to reopen automatically</p>

			Photo #:	<ul style="list-style-type: none"> • Install opener •
<p>2.24 If there is a LULA elevator with a swinging door:</p> <p>Is the door power- operated? <input type="checkbox"/> Yes <input type="checkbox"/> No</p> <p>Does the door remain open for at least 20 seconds when activated? <input type="checkbox"/> Yes <input type="checkbox"/> No</p> <p>Time:</p>			Photo #:	<ul style="list-style-type: none"> • Add power operated door • Adjust opening time •
<p>2.25 If there is a full size elevator:</p> <p>Is the interior at least 54 inches deep by at least 36 inches wide with at least 16 sq. ft. of clear floor area? <input type="checkbox"/> Yes <input type="checkbox"/> No</p> <p>Measurement:</p> <p>Is the door opening width at least 32 inches? <input type="checkbox"/> Yes <input type="checkbox"/> No</p> <p>Measurement:</p>			Photo #:	<ul style="list-style-type: none"> • Replace elevator • •
<p>2.26 If there is a LULA elevator, is the interior:</p> <p>At least 51 x 51 inches with a door opening width of at least 36 inches? <input type="checkbox"/> Yes <input type="checkbox"/> No</p> <p>Measurement:</p> <p>Or</p> <p>At least 54 inches deep by at least 36 inches wide with at least 15 sq. ft. of clear floor <input type="checkbox"/> Yes <input type="checkbox"/> No</p> <p>Measurement:</p>				<ul style="list-style-type: none"> • Replace elevator • •

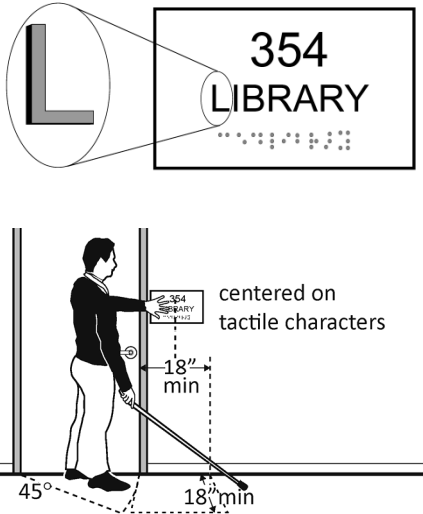
<p>area and a door opening width of at least 32 inches?</p>			Photo #:	
<p>2.27 If there is a full size or LULA elevator, are the in-car controls:</p> <p>No less than 15 inches and no greater 48 inches above the floor? Or Up to 54 inches above the floor for a parallel approach?</p>	<p><input type="checkbox"/> Yes <input type="checkbox"/> No Measurement:</p> <p><input type="checkbox"/> Yes <input type="checkbox"/> No Measurement:</p>	 <p>Or</p>	Photo #:	<ul style="list-style-type: none"> • Change control height • •
<p>2.28 If there is a LULA elevator, are the in-car controls centered on a side wall?</p>	<p><input type="checkbox"/> Yes <input type="checkbox"/> No Measurement:</p>		Photo #:	<ul style="list-style-type: none"> • Reconfigure controls • •

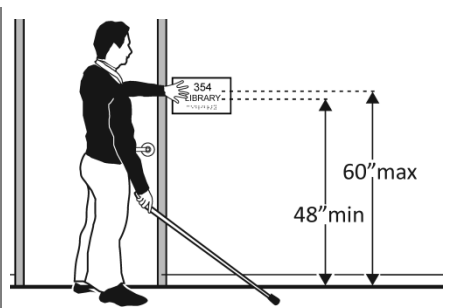
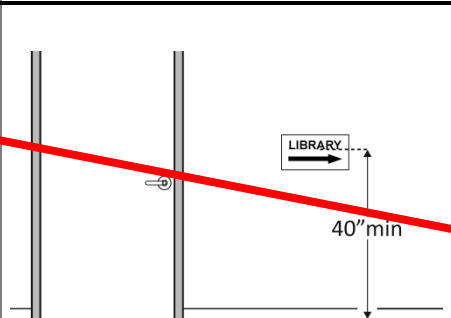
<p>2.29 If there is a full size or LULA elevator:</p> <p>Are the car control buttons designated with raised characters?</p> <p>Are the car control buttons designated with Braille?</p>	<p><input type="checkbox"/> Yes <input type="checkbox"/> No</p> <p><input type="checkbox"/> Yes <input type="checkbox"/> No</p>		<p>Photo #:</p>	<ul style="list-style-type: none"> • Add raised characters • Add Braille •
<p>2.30 If there is a full size or LULA elevator, are there audible signals which sound as the car passes or is about to stop at a floor?</p>	<p><input type="checkbox"/> Yes <input type="checkbox"/> No</p>		<p>Photo #:</p>	<ul style="list-style-type: none"> • Install audible signals • •
<p>2.31 If there is a full size or LULA elevator:</p> <p>Is there a sign on both door jambs at every floor identifying the floor?</p> <p>Is there a tactile star on both jambs at the main entry level?</p> <p>Do text characters contrast with their backgrounds?</p> <p>Are text characters raised?</p> <p>Is there Braille?</p> <p>Is the sign mounted between 48 inches to the baseline of the lowest character and 60 inches to the baseline of the highest character above the floor?*</p>	<p><input type="checkbox"/> Yes <input type="checkbox"/> No</p> <p><input type="checkbox"/> Yes <input type="checkbox"/> No</p> <p><input type="checkbox"/> Yes <input type="checkbox"/> No</p> <p><input type="checkbox"/> Yes <input type="checkbox"/> No</p> <p><input type="checkbox"/> Yes <input type="checkbox"/> No</p> <p><input type="checkbox"/> Yes <input type="checkbox"/> No</p> <p>Measurement:</p>		<p>Photo #:</p>	<ul style="list-style-type: none"> • Install signs • Change sign height • • <p>* If constructed before 3/15/2012 and mounted no higher than 60 inches to the centerline of the sign, relocation is not required</p>

Platform Lifts (2010 Standards – 410)				
<p>2.32 If a lift is provided, can it be used without assistance from others?</p>	<p><input type="checkbox"/> Yes <input type="checkbox"/> No</p>		<p>Photo #:</p>	<ul style="list-style-type: none"> • Reconfigure so independently operable • •
<p>2.33 Is there a clear floor space at least 30 inches wide by at least 48 inches long for a person using a wheelchair to approach and reach the controls to use the lift?</p>	<p><input type="checkbox"/> Yes <input type="checkbox"/> No</p> <p>Measurement:</p>		<p>Photo #:</p>	<ul style="list-style-type: none"> • Remove obstructions • •
<p>2.34 Are the lift controls no less than 15 inches and no greater than 48 inches above the floor?</p>	<p><input type="checkbox"/> Yes <input type="checkbox"/> No</p> <p>Measurement:</p>		<p>Photo #:</p>	<ul style="list-style-type: none"> • Change control height • •
<p>2.35 Is there a clear floor space at least 30 inches wide by at least 48 inches long inside the lift?</p>	<p><input type="checkbox"/> Yes <input type="checkbox"/> No</p> <p>Measurement:</p>		<p>Photo #:</p>	<ul style="list-style-type: none"> • Replace lift • •

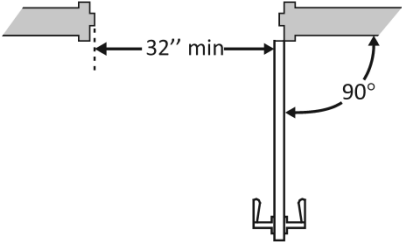
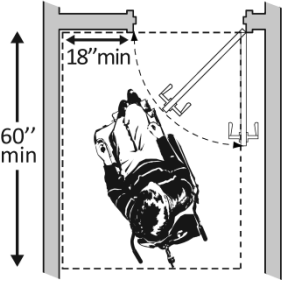
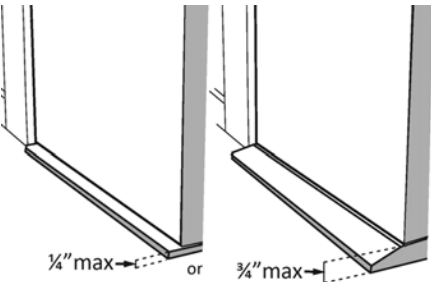
<p>2.36 If there is an end door, is the clear opening width at least 32 inches?</p>	<p><input type="checkbox"/> Yes <input type="checkbox"/> No</p> <p>Measurement:</p>		<p>Photo #:</p>	<ul style="list-style-type: none"> • Alter door width • •
<p>2.37 If there is a side door, is the clear opening width at least 42 inches?</p>	<p><input type="checkbox"/> Yes <input type="checkbox"/> No</p> <p>Measurement:</p>		<p>Photo #:</p>	<ul style="list-style-type: none"> • Alter door width • •

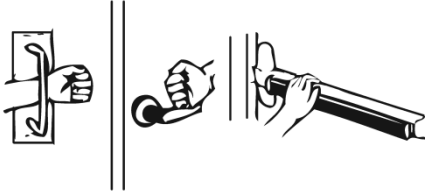
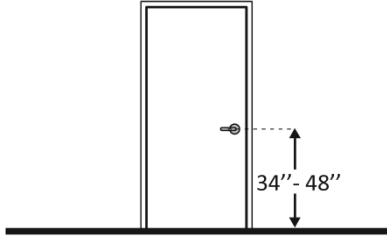
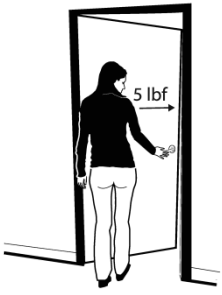
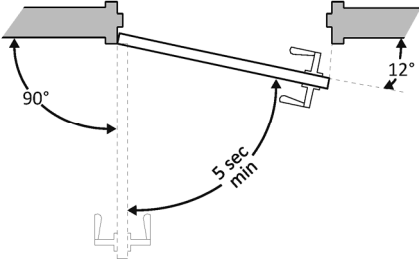
Signs (2010 Standards – 703) Note: “Tactile characters” are read using touch, i.e. raised characters and Braille.

<p>2.38 If there are signs designating permanent rooms and spaces not likely to change over time, e.g. room numbers and letters, room names, and exit signs:</p> <p>Do text characters contrast with their backgrounds?</p> <p>Are text characters raised?</p> <p>Is there Braille?</p> <p>Is the sign mounted: On the wall on the latch side of the door?</p>	<p><input checked="" type="checkbox"/> Yes <input type="checkbox"/> No</p> <p><input checked="" type="checkbox"/> Yes <input type="checkbox"/> No</p> <p><input type="checkbox"/> Yes <input checked="" type="checkbox"/> No</p> <p><input type="checkbox"/> Yes <input checked="" type="checkbox"/> No</p>		<ul style="list-style-type: none"> • No 18" side clearance provided 	<ul style="list-style-type: none"> • Install tactile sign • Relocate sign •
---	---	---	---	--

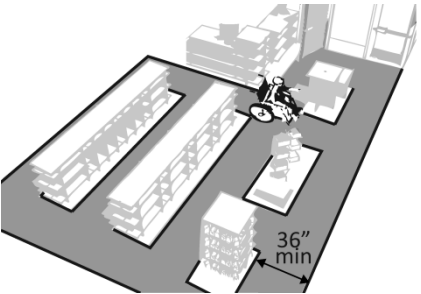
<p>Note: Signs are permitted on the push side of doors with closers and without hold-open devices.</p> <p>With clear floor space beyond the arc of the door swing between the closed position and 45-degree open position, at least 18 x 18 inches centered on the tactile characters?*</p> <p>So the baseline of the lowest character is at least 48 inches above the floor and the baseline of the highest character is no more than 60 inches above the floor? *</p> <p>Note: If the sign is at double doors with one active leaf, the sign should be on the inactive leaf; if both leaves are active, the sign should be on the wall to the right of the right leaf.</p>	<p><input checked="" type="checkbox"/> Yes <input type="checkbox"/> No</p> <p>Measurement:</p> <p><input type="checkbox"/> Yes <input type="checkbox"/> No</p> <p>Measurement:</p> <p>Signs ok @ Men's and Women's</p>		<p>Photo #: 43 Women's & Men's Similar</p>	<p>*If constructed before 3/15/2010 and a person may approach within 3 inches of the sign without encountering protruding objects or standing within the door swing, relocation not required</p> <p>*If constructed before 3/15/2012 and mounted no higher than 60 inches to the centerline of the sign, relocation not required</p>
<p>2.39 If there are signs that provide direction to or information about interior spaces:</p> <p>Do text characters contrast with their backgrounds?</p> <p>Is the sign mounted so that characters are at least 40 inches above the floor?</p>	<p><input type="checkbox"/> Yes <input type="checkbox"/> No</p> <p><input type="checkbox"/> Yes <input type="checkbox"/> No</p> <p>Measurement:</p>		<p>Photo #:</p>	<p>• Install signs with contrasting characters</p> <p>• Change sign height</p> <p>•</p> <p>Raised characters and Braille are not required</p>

Interior Doors – to classrooms, medical exam rooms, conference rooms, etc. (2010 Standards – 404)


<p>2.40 Is the door opening width at least 32 inches clear, between the face of the door and the stop, when the door is open 90 degrees?</p>	<p><input type="checkbox"/> Yes <input type="checkbox"/> No</p> <p>Measurement:</p> <p>34 +"</p>		<p>Photo #: 46 Men & similar in Women's</p>	<ul style="list-style-type: none"> • Install offset hinges • Alter the doorway •
<p>2.41 If there is a front approach to the pull side of the door, is there at least 18 inches of maneuvering clearance beyond the latch side plus at least 60 inches clear depth?</p> <p>On both sides of the door, is the floor surface of the maneuvering clearance level (no steeper than 1:48)?</p>	<p><input type="checkbox"/> Yes <input type="checkbox"/> No</p> <p>Measurement:</p> <p><input type="checkbox"/> Yes <input type="checkbox"/> No</p> <p>Measurement:</p>		<p>Photo #:</p>	<ul style="list-style-type: none"> • Remove obstructions • Reconfigure walls • Add automatic door opener <p>See 2010 Standards 404.2.4 for maneuvering clearance requirements on the push side of the door and side approaches to the pull side of the door</p>
<p>2.42 Is the door threshold edge no more than ¼ inch high?</p> <p>Or</p> <p>No more than ¾ inch high if slope is beveled no steeper than 1:2?</p> <p>Note: The first ¼ inch of the threshold may be vertical; the rest must be beveled.</p>	<p><input checked="" type="checkbox"/> Yes <input type="checkbox"/> No</p> <p>Measurement:</p> <p><input type="checkbox"/> Yes <input type="checkbox"/> No</p> <p>Measurement:</p>		<ul style="list-style-type: none"> • No Threshold in Men's or Women's <p>Photo #: 48 Women's</p>	<ul style="list-style-type: none"> • Remove or replace threshold • •

<p>2.43 Is the door equipped with hardware that is operable with one hand and does not require tight grasping, pinching and twisting of the wrist?</p>	<p><input type="checkbox"/> Yes <input checked="" type="checkbox"/> No</p>		<ul style="list-style-type: none"> • 1 ½" Clearance • Similar in Men's and Women's <p>Photo #: 52 Men's</p>	<ul style="list-style-type: none"> • Replace inaccessible knob with lever, loop or push hardware • Add automatic door opener •
<p>2.44 Are the operable parts of the hardware no less than 34 inches and no greater than 48 inches above the floor?</p>	<p><input checked="" type="checkbox"/> Yes <input type="checkbox"/> No</p> <p>Measurement: Pull Handle 38" Center Line for both Men's & Women's</p>		<p>Photo #:</p>	<ul style="list-style-type: none"> • Change hardware height • •
<p>2.45 Can the door be opened easily (5 pounds maximum force)?</p> <p>Note: You can use a pressure gauge or fish scale to measure force. If you do not have a pressure gauge or fish scale you will need to judge whether the door is easy to open.</p>	<p><input type="checkbox"/> Yes <input type="checkbox"/> No</p> <p>Measurement: 10 lbs for both Men's & Women's</p>		<p>Photo #: 50 Men's</p>	<ul style="list-style-type: none"> • Adjust or replace closers • Install lighter doors • Install power-assisted or automatic door openers
<p>2.46 If the door has a closer, does it take at least 5 seconds to close from an open position of 90 degrees to a position of 12 degrees from the latch?</p>	<p><input checked="" type="checkbox"/> Yes <input type="checkbox"/> No</p> <p>Measurement:</p>		<p>Photo #: 49 Men's</p>	<ul style="list-style-type: none"> • Adjust closer • •

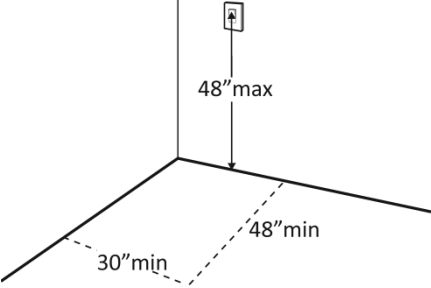
Rooms and Spaces – stores, supermarkets, libraries, etc. (2010 Standards – 302, 304, & 402)

<p>2.47 Are aisles and pathways to goods and services, and to one of each type of sales and service counters, at least 36 inches wide?</p>	<p><input checked="" type="checkbox"/> Yes <input type="checkbox"/> No</p> <p>Measurement:</p>		<p>• No Display Racks are out</p> <p>Photo #:</p>	<ul style="list-style-type: none"> • Rearrange goods, equipment and furniture • •
---	--	--	--	--

<p>2.48 Are floor surfaces stable, firm and slip resistant?</p>	<p><input checked="" type="checkbox"/> Yes <input type="checkbox"/> No</p>		<p>• Red Floor tile/worn</p> <p>Photo #:</p>	<ul style="list-style-type: none"> • Change floor surface • •
--	--	--	---	--

<p>2.49 If there is carpet:</p> <p>Is it no higher than ½ inch?</p> <p>Is it securely attached along the edges?</p>	<p><input type="checkbox"/> Yes <input checked="" type="checkbox"/> No</p> <p>Measurement:</p> <p><input type="checkbox"/> Yes <input type="checkbox"/> No</p>		<p>Photo #:</p>	<ul style="list-style-type: none"> • Replace carpet • •
--	--	--	-----------------	--

Controls – light switches, security and intercom systems, emergency/alarm boxes, etc. (2010 Standards – 309)

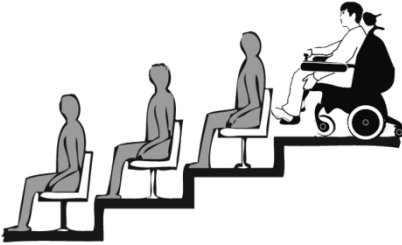
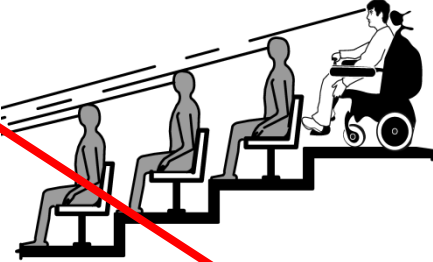
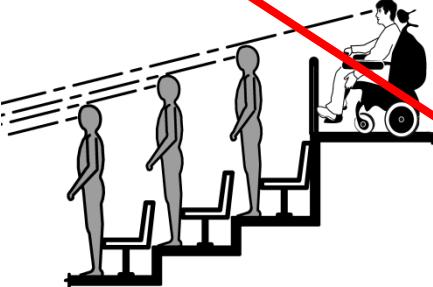

<p>2.50 Is there a clear floor space at least 30 inches wide by at least 48 inches long for a forward or parallel approach?</p> <p>Are the operable parts no higher than 48 inches above the floor?*</p>	<p><input type="checkbox"/> Yes <input type="checkbox"/> No</p> <p>Measurement:</p> <p><input type="checkbox"/> Yes <input type="checkbox"/> No</p> <p>Measurement:</p>		<p>• None in public spaces</p>	<ul style="list-style-type: none"> • Change height of control • • <p>*If constructed before 3/15/2012 and a parallel approach is provided, controls can be 54 inches</p>
---	---	--	---------------------------------------	---

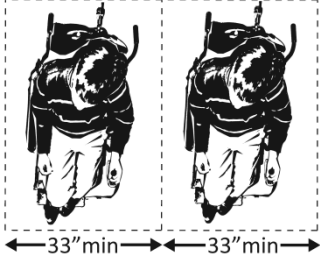
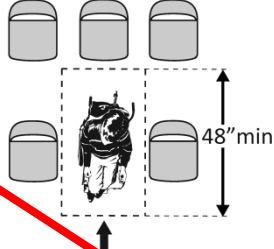
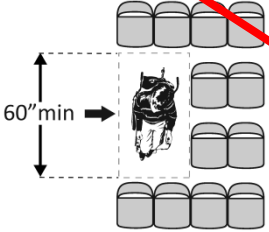
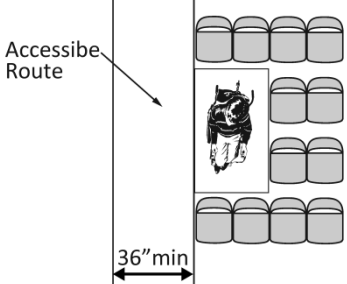
				above the floor
			Photo #:	

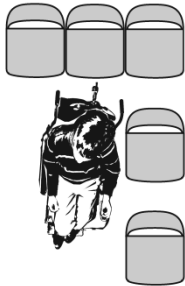

<p>2.51 Can the control be operated with one hand and without tight grasping, pinching, or twisting of the wrist?</p>	<input type="checkbox"/> Yes <input type="checkbox"/> No		Photo #:	<ul style="list-style-type: none"> • Replace control • •
--	--	--	----------	---

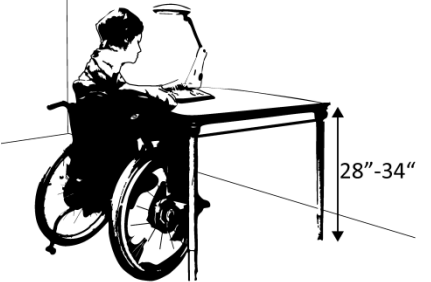
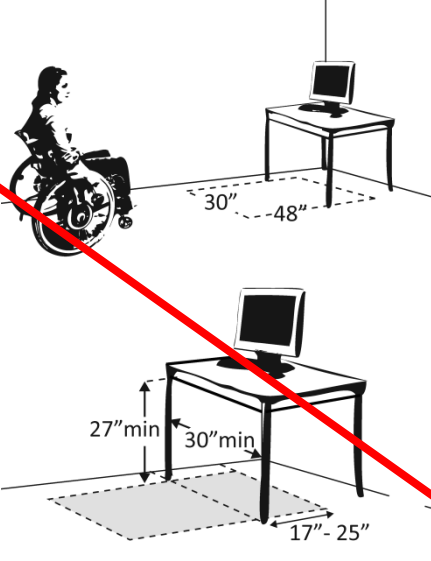
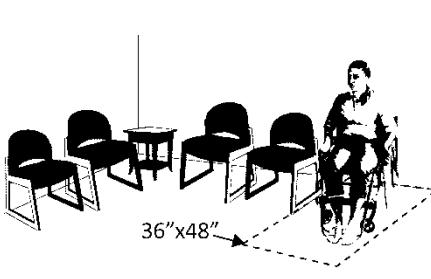
Seating: Assembly Areas – theaters, auditoriums, stadiums, theater style classrooms, etc. (2010 Standards – 221 & 802)

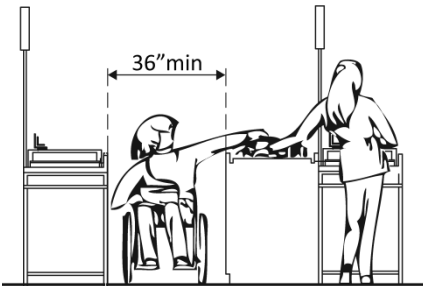
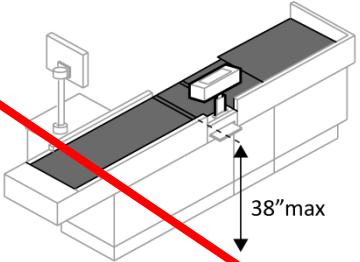
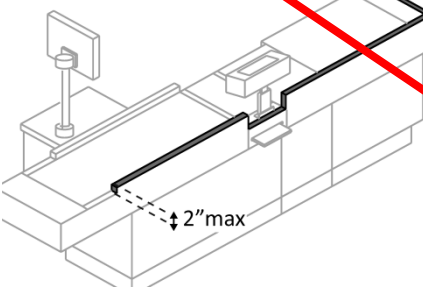
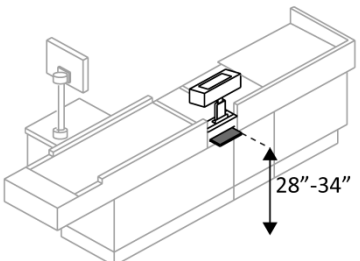
<p>2.52 Are an adequate number of wheelchair spaces provided?</p>	<input type="checkbox"/> Yes <input type="checkbox"/> No	<table border="1"> <thead> <tr> <th># of Seats</th> <th>Wheelchair Spaces</th> </tr> </thead> <tbody> <tr> <td>4 - 25</td> <td>1</td> </tr> <tr> <td>26 - 50</td> <td>2</td> </tr> <tr> <td>51 - 150</td> <td>4</td> </tr> <tr> <td>151 - 300</td> <td>5</td> </tr> <tr> <td colspan="2">300+ see 2010 Standards 221.2.1.</td> </tr> </tbody> </table>	# of Seats	Wheelchair Spaces	4 - 25	1	26 - 50	2	51 - 150	4	151 - 300	5	300+ see 2010 Standards 221.2.1.		Photo #:	<ul style="list-style-type: none"> • Reconfigure to add wheelchair spaces • •
# of Seats	Wheelchair Spaces															
4 - 25	1															
26 - 50	2															
51 - 150	4															
151 - 300	5															
300+ see 2010 Standards 221.2.1.																

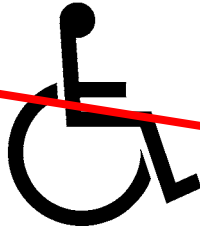
<p>2.53 Are wheelchair spaces dispersed to allow location choices and viewing angles equivalent to other seating, including specialty seating areas that provide distinct services and amenities?</p>	<p><input type="checkbox"/> Yes <input type="checkbox"/> No</p>		<p>Photo #:</p>	<ul style="list-style-type: none"> • Reconfigure to disperse wheelchair spaces • •
<p>2.54 Where people are expected to remain seated, do people in wheelchair spaces have a clear line of sight over and between the heads of others in front of them?</p>	<p><input type="checkbox"/> Yes <input type="checkbox"/> No</p>		<p>Photo #:</p>	<ul style="list-style-type: none"> • Alter for line of sight • •
<p>2.55 Where people are expected to stand, do people in wheelchair spaces have a clear line of sight over and between the heads of others in front of them?</p>	<p><input type="checkbox"/> Yes <input type="checkbox"/> No</p>		<p>Photo #:</p>	<ul style="list-style-type: none"> • Alter for line of sight • •
<p>2.56 If there is a single wheelchair space, is it at least 36 inches wide?</p>	<p><input type="checkbox"/> Yes <input type="checkbox"/> No</p> <p>Measurement:</p>		<p>Photo #:</p>	<ul style="list-style-type: none"> • Alter space • •

<p>2.57 If there are two adjacent wheelchair spaces, are they each at least 33 inches wide?</p>	<p><input type="checkbox"/> Yes <input type="checkbox"/> No</p> <p>Measurement:</p>		<p>Photo #:</p>	<ul style="list-style-type: none"> • Alter spaces • •
<p>2.58 If the wheelchair space can be entered from the front or rear, is it at least 48 inches deep?</p>	<p><input type="checkbox"/> Yes <input type="checkbox"/> No</p> <p>Measurement:</p>		<p>Photo #:</p>	<ul style="list-style-type: none"> • Alter space • •
<p>2.59 If the wheelchair space can only be entered from the side, is it at least 60 inches deep?</p>	<p><input type="checkbox"/> Yes <input type="checkbox"/> No</p> <p>Measurement:</p>		<p>Photo #:</p>	<ul style="list-style-type: none"> • Alter space • •
<p>2.60 Do wheelchair spaces adjoin, but not overlap, accessible routes?</p>	<p><input type="checkbox"/> Yes <input type="checkbox"/> No</p>		<p>Photo #:</p>	<ul style="list-style-type: none"> • Alter spaces • •

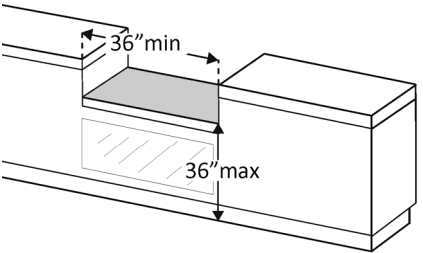
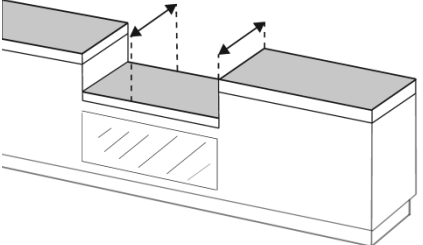
<p>2.61 Is there at least one companion seat for each wheelchair space?</p>	<p><input type="checkbox"/> Yes <input type="checkbox"/> No</p>		<p>Photo #:</p>	<ul style="list-style-type: none"> • Add companion seats • •
<p>2.62 Is the companion seat located so the companion is shoulder-to-shoulder with the person in a wheelchair?</p>	<p><input type="checkbox"/> Yes <input type="checkbox"/> No</p>		<p>Photo #:</p>	<ul style="list-style-type: none"> • Alter seating • •
<p>2.63 Is the companion seat equivalent in size, quality, comfort and amenities to seating in the immediate area?</p>	<p><input type="checkbox"/> Yes <input type="checkbox"/> No</p>		<p>Photo #:</p>	<ul style="list-style-type: none"> • Add equivalent seating • •
<p>Seating: At dining surfaces (restaurants, cafeterias, bars, etc.) and non-employee work surfaces (libraries, conference rooms, etc.) (2010 Standards – 226 & 902)</p>				
<p>2.64 Are at least 5%, but no fewer than one, of seating and standing spaces accessible for people who use wheelchairs?</p>	<p><input type="checkbox"/> Yes <input type="checkbox"/> No</p> <p>Total #:</p> <p>Wheelchair #:</p>		<p>Photo #:</p>	<ul style="list-style-type: none"> • Alter to provide accessible spaces • •
<p>2.65 Is there a route at least 36 inches wide to accessible seating?</p>	<p><input type="checkbox"/> Yes <input type="checkbox"/> No</p> <p>Measurement:</p>		<p>Photo #:</p>	<ul style="list-style-type: none"> • Widen route • •

<p>2.66 At the accessible space(s), is the top of the accessible surface no less than 28 inches and no greater than 34 inches above the floor?</p>	<p><input type="checkbox"/> Yes <input type="checkbox"/> No</p> <p>Measurement:</p>		<p>Photo #:</p>	<ul style="list-style-type: none"> • Alter surface height • •
<p>2.67 Is there a clear floor space at least 30 inches wide by at least 48 inches long for a forward approach?</p> <p>Does it extend no less than 17 inches and no greater than 25 inches under the surface?</p> <p>Is there knee space at least 27 inches high and at least 30 inches wide?</p>	<p><input type="checkbox"/> Yes <input type="checkbox"/> No</p> <p>Measurement:</p> <p><input type="checkbox"/> Yes <input type="checkbox"/> No</p> <p>Measurement:</p> <p><input type="checkbox"/> Yes <input type="checkbox"/> No</p> <p>Measurement:</p>		<p>Photo #:</p>	<ul style="list-style-type: none"> • Alter table or work surface • Add accessible table or work surface •
<p>Seating: General – reception areas, waiting rooms, etc. (2010 Standards – 801)</p>				
<p>2.68 Is there at least one space at least 36 inches wide by at least 48 inches long for a person in a wheelchair?</p>	<p><input type="checkbox"/> Yes <input type="checkbox"/> No</p> <p>Measurement:</p>		<p>Photo #:</p>	<ul style="list-style-type: none"> • Move furniture and equipment to provide space • •

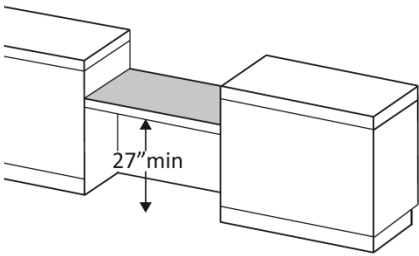
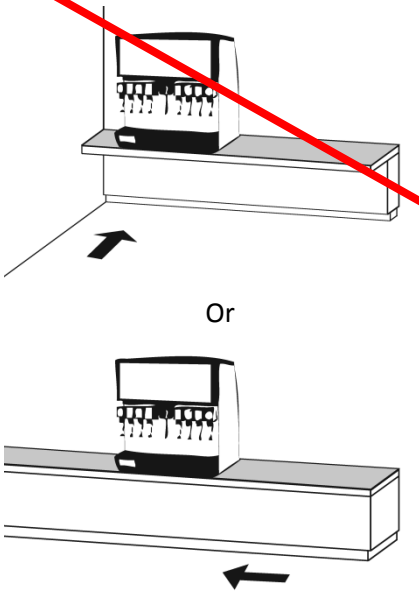
Check-Out Aisles – supermarkets, large retail stores, etc. (2010 Standards – 904)				
<p>2.71 Is the aisle at least 36 inches wide?</p>	<p><input type="checkbox"/> Yes <input type="checkbox"/> No</p> <p>Measurement:</p>		<p>Photo #:</p>	<ul style="list-style-type: none"> • Widen aisle • •
<p>2.72 Is the counter surface of at least one aisle no higher than 38 inches above the floor?</p>	<p><input type="checkbox"/> Yes <input type="checkbox"/> No</p> <p>Measurement:</p>		<p>Photo #:</p>	<ul style="list-style-type: none"> • Lower counter • •
<p>2.73 Is the top of the counter edge protection no higher than 2 inches above the counter surface?</p>	<p><input type="checkbox"/> Yes <input type="checkbox"/> No</p> <p>Measurement:</p>		<p>Photo #:</p>	<ul style="list-style-type: none"> • Lower edge protection • •
<p>2.74 If there is a check writing surface, is the top no less than 28 inches and no greater than 34 inches above the floor?</p>	<p><input type="checkbox"/> Yes <input type="checkbox"/> No</p> <p>Measurement:</p>		<p>Photo #:</p>	<ul style="list-style-type: none"> • Alter check writing surface • •

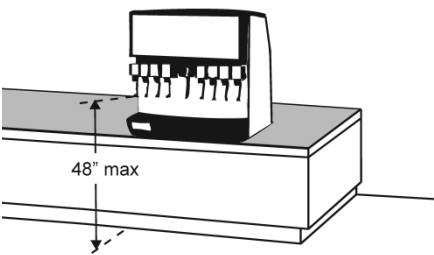
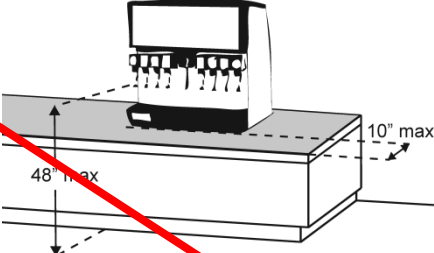
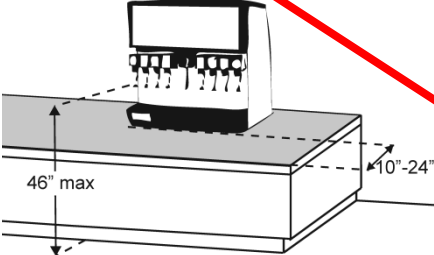
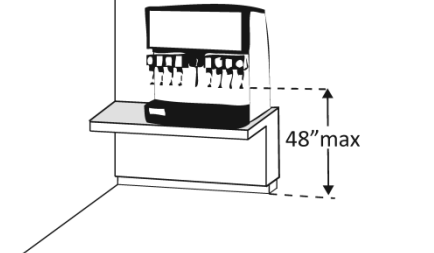
<p>2.75 If there is more than one check-out aisle is there a sign with the International Symbol of Accessibility at the accessible aisle?</p>	<p><input type="checkbox"/> Yes <input type="checkbox"/> No</p>		<p>Photo #:</p>	<ul style="list-style-type: none"> • Add sign • •
---	---	---	-----------------	--

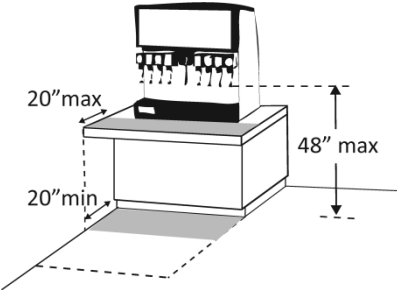
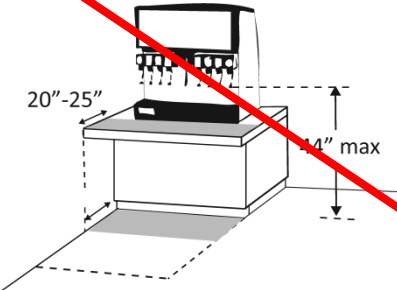
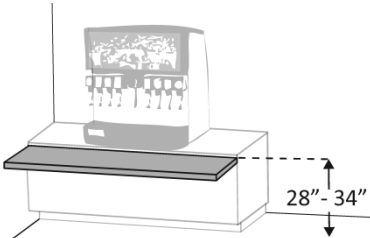
Sales & Service Counters – banks, stores, dry cleaners, auto repair shops, fitness clubs, etc. (2010 Standards – 904)

<p>2.76 Is there a portion of at least one of each type of counter that is:</p> <p>No higher than 36 inches above the floor?</p> <p>At least 36 inches long?</p>	<p><input type="checkbox"/> Yes <input checked="" type="checkbox"/> No Measurement:</p> <p><input type="checkbox"/> Yes <input checked="" type="checkbox"/> No Measurement:</p>		<p>• 2 COUNTERS</p> <p>Photo #: 56</p>	<ul style="list-style-type: none"> • Lower section of counter • Lengthen section of counter •
<p>2.77 Does the accessible portion of the counter extend the same depth as the counter top?</p>	<p><input type="checkbox"/> Yes <input checked="" type="checkbox"/> No Measurement:</p>		<p>Photo #:</p>	<ul style="list-style-type: none"> • Alter accessible portion • •

<p>2.78 Is there a clear floor space at least 30 inches wide by at least 48 inches long for a forward or parallel approach?</p>	<p><input type="checkbox"/> Yes <input type="checkbox"/> No</p> <p><input type="checkbox"/> Parallel Measurement:</p> <p><input type="checkbox"/> Forward Measurement:</p>		<p>Photo #:</p>	<ul style="list-style-type: none"> • Reconfigure to provide a parallel or forward approach • •
<p>2.79 For a parallel approach, is the clear floor space positioned with the 48 inches adjacent to the accessible length of counter?</p>	<p><input type="checkbox"/> Yes <input type="checkbox"/> No</p> <p>Measurement:</p>		<p>Photo #:</p>	<ul style="list-style-type: none"> • If a parallel approach is not possible, a forward approach is required • •
<p>2.80 For a forward approach:</p> <p>Do no less than 17 and no greater than 25 inches of the clear floor space extend under the accessible length of the counter?</p> <p>Is there at least 27 inches clearance from the floor to the</p>	<p><input type="checkbox"/> Yes <input type="checkbox"/> No</p> <p>Measurement:</p> <p><input type="checkbox"/> Yes <input type="checkbox"/> No</p>		<p>Photo #:</p>	<ul style="list-style-type: none"> • Reconfigure to provide knee clearance • •

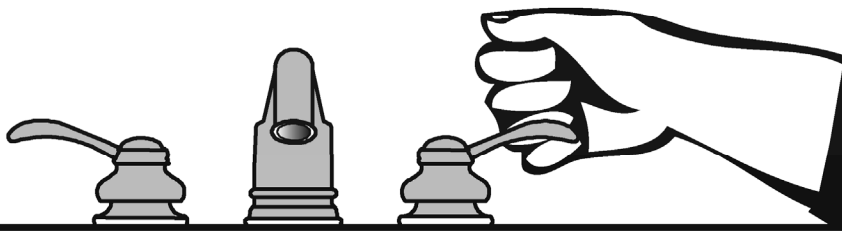
<p>bottom of the counter?</p>	<p>Measurement:</p>		<p>Photo #:</p>	
<p>Food Service Lines – in cafeterias, salad bars, eat-in fast food establishments, etc. (2010 Standards – 904)</p>				
<p>2.81 Does at least one of each type of self-service shelf or dispensing device for tableware, dishware, condiments, food and beverages have a forward or parallel approach?</p>	<p><input type="checkbox"/> Yes <input type="checkbox"/> No</p> <p><input type="checkbox"/> Forward</p> <p><input type="checkbox"/> Parallel</p>		<p>Photo #:</p>	<ul style="list-style-type: none"> • Reconfigure to provide approach • •

<p>2.82 If there is an unobstructed parallel approach, is the shelf or dispensing device no higher than 48 inches above the floor?</p>	<p><input type="checkbox"/> Yes <input type="checkbox"/> No</p> <p>Measurement:</p>		<p>Photo #:</p>	<ul style="list-style-type: none"> • Lower shelf and/or dispensing device • •
<p>2.83 If there is a shallow obstruction no deeper than 10 inches with a parallel approach, is the shelf or dispensing device no higher than 48 inches above the floor?</p>	<p><input type="checkbox"/> Yes <input type="checkbox"/> No</p> <p>Measurement:</p>		<p>Photo #:</p>	<ul style="list-style-type: none"> • Lower shelf and/or dispensing device • •
<p>2.84 If there is an obstruction no less than 10 inches and no greater than 24 inches deep with a parallel approach, is the shelf or dispensing device no higher than 46 inches above the floor?</p>	<p><input type="checkbox"/> Yes <input type="checkbox"/> No</p> <p>Measurement:</p>		<p>Photo #:</p>	<ul style="list-style-type: none"> • Lower shelf and/or dispensing device • •
<p>2.85 If there is an unobstructed forward approach, is the shelf or dispensing device no higher than 48 inches above the floor?</p>	<p><input type="checkbox"/> Yes <input type="checkbox"/> No</p> <p>Measurement:</p>		<p>Photo #:</p>	<ul style="list-style-type: none"> • Lower shelf and/or dispensing device • •

<p>2.86 If there is an obstruction no deeper than 20 inches with a forward approach:</p> <p>Does clear floor space extend under the obstruction that is at least the same depth as the obstruction?</p> <p>Is the shelf or dispensing device no higher than 48 inches above the floor?</p>	<p><input type="checkbox"/> Yes <input type="checkbox"/> No Measurement:</p> <p><input type="checkbox"/> Yes <input type="checkbox"/> No Measurement:</p>		<p>Photo #:</p>	<ul style="list-style-type: none"> • Reconfigure to provide knee space • Lower shelf and/or dispensing device •
<p>2.87 If the obstruction is no less than 20 inches and no greater than 25 inches deep with a forward approach:</p> <p>Does clear floor space extend under the obstruction that is at least the same depth as the obstruction?</p> <p>Is the shelf or dispensing device no higher than 44 inches above the floor?</p>	<p><input type="checkbox"/> Yes <input type="checkbox"/> No Measurement:</p> <p><input type="checkbox"/> Yes <input type="checkbox"/> No Measurement:</p>		<p>Photo #:</p>	<ul style="list-style-type: none"> • Reconfigure to provide knee space • Lower shelf and/or dispensing device •
<p>2.88 If there is a tray slide, is the top no less than 28 inches and no greater than 34 inches above the floor?</p>	<p><input type="checkbox"/> Yes <input type="checkbox"/> No Measurement:</p>		<p>Photo #:</p>	<ul style="list-style-type: none"> • Reconfigure • •

The ADA Checklist for Readily Achievable Barrier Removal

Priority 3 – Women's Toilet Rooms



Project **SDDOT Rest Area Improvements**
FHU Reference Number 13-039-01
TSP Project Number 03120855

Building **TILFORD WEST**

Location **90 W., MRM 41**

Date **09-19-2013 (Inspection)**

Surveyors **Timothy Roach, AIA**
Todd Schultz, PE

Contact Information **TSP – (605) 343-6102**

When toilet rooms are open to the public they should be accessible to people with disabilities.





Institute for Human Centered Design
www.HumanCenteredDesign.org

November 2011



ADA National Network
Questions on the ADA 800-949-4232 voice/tty
www.ADAchecklist.org

Priority 3 – Toilet Rooms		Comments	Possible Solutions
<p>3.1 If toilet rooms are available to the public, is at least one toilet room accessible? (Either one for each sex, or one unisex.)</p>	<input checked="" type="checkbox"/> Yes <input type="checkbox"/> No	<p>Photo #:</p>	<ul style="list-style-type: none"> • Reconfigure toilet rooms • Combine toilet rooms to create one unisex accessible toilet room •
<p>3.2 Are there signs at inaccessible toilet rooms that give directions to accessible toilet rooms?</p>	<input type="checkbox"/> Yes <input type="checkbox"/> No	 <p>Photo #:</p>	<p>NA</p> <ul style="list-style-type: none"> • Install signs • •
<p>3.3 If not all toilet rooms are accessible, is there a sign at the accessible toilet room with the International Symbol of Accessibility?</p>	<input type="checkbox"/> Yes <input type="checkbox"/> No	 <p>Photo #:</p>	<p>NA</p> <ul style="list-style-type: none"> • Install sign • •
<p>Accessible Route (2010 Standards – Chapter 4)</p>			
<p>3.4 Is there a route to the accessible toilet room(s) that does not include the use of stairs?</p>	<input checked="" type="checkbox"/> Yes <input type="checkbox"/> No	<p>Photo #:</p>	<ul style="list-style-type: none"> • Insufficient clearance @ door • •
<p>Is the route accessible? (See Priority 2 Interior Accessible Route for specifics.)</p>	<input type="checkbox"/> Yes <input checked="" type="checkbox"/> No		

Signs at Toilet Rooms (2010 Standards – 703)

3.5 Do text characters contrast with their backgrounds?

Yes No

Are text characters raised?

Yes No

Is there Braille?

Yes No

Is the sign mounted:
On the wall on the latch side of the door?

Yes No

Note:

Signs are permitted on the push side of doors with closers and without hold-open devices.

With clear floor space beyond the arc of the door swing and 45-degree open position, at least 18 x 18 inches centered on the tactile characters? *

Yes No

Measurement:

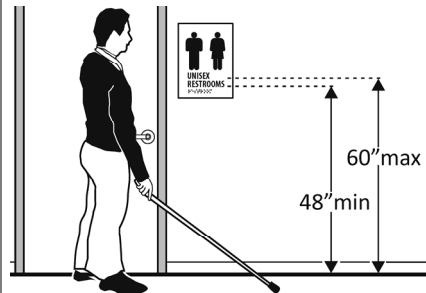
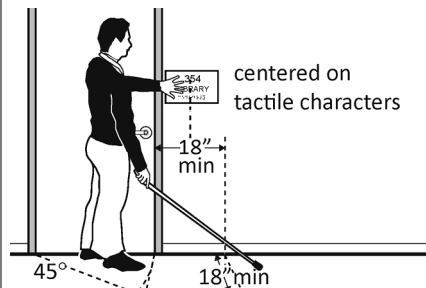
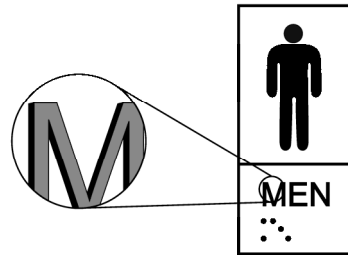
So the baseline of the lowest character is at least 48 inches above the floor and the baseline of the highest character is no more than 60 inches above the floor? *

Yes No

Measurement:

Note:

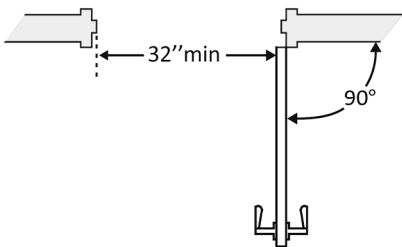
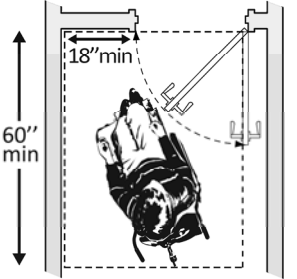
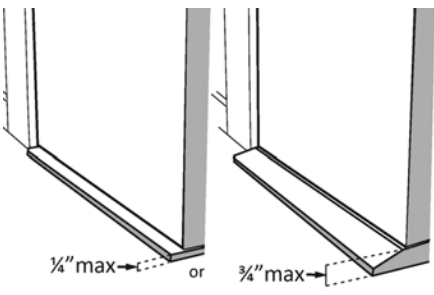
If the sign is at double doors with one active leaf, the sign should be on the inactive leaf; if both leaves are active, the sign

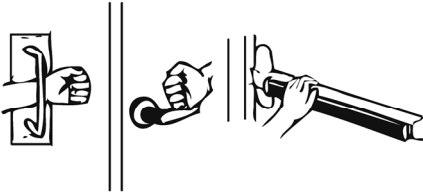
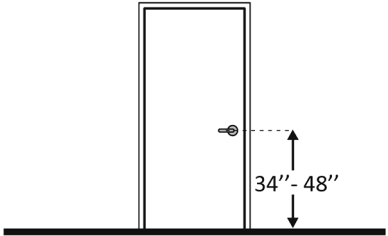

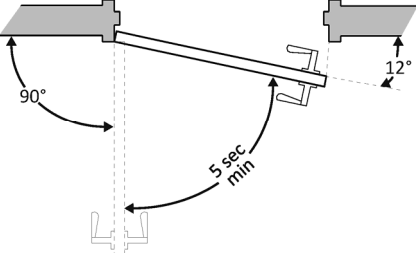


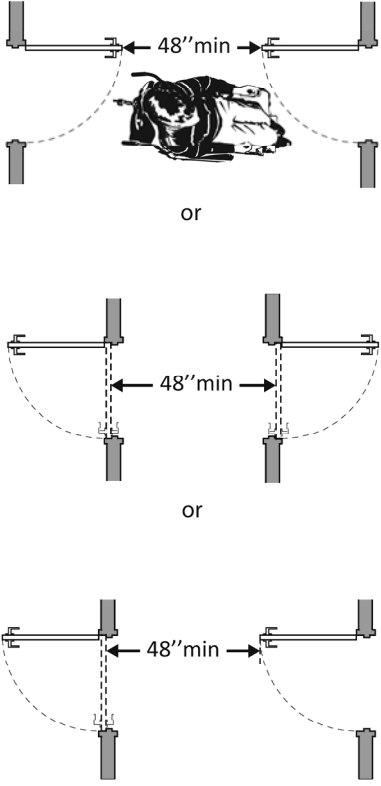
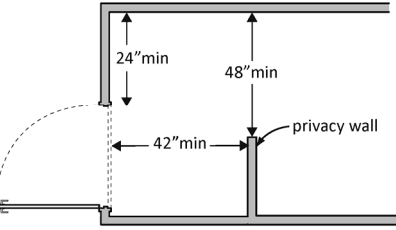
- Install tactile sign
- Relocate sign
-

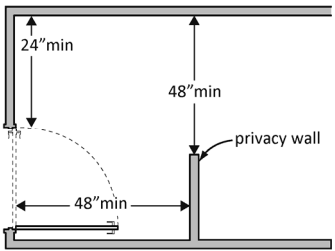

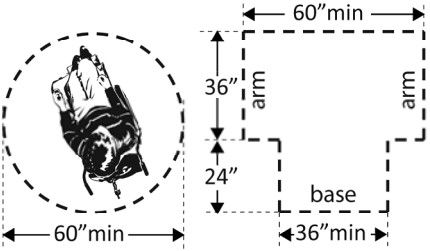
*If constructed before 3/15/2010 and a person may approach within 3 inches of the sign without encountering protruding objects or standing within the door swing, relocation not required

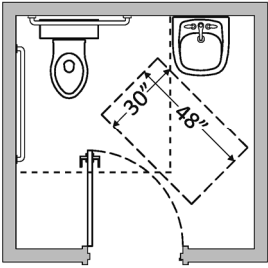
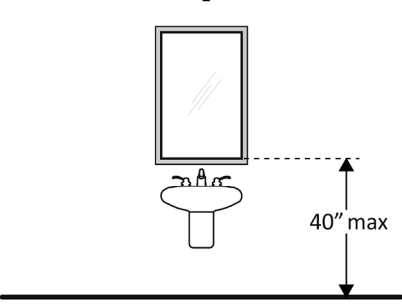
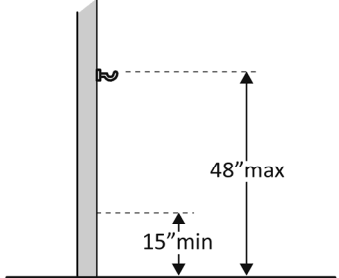
*If constructed before 3/15/2012 and mounted no higher than 60 inches to the centerline of the sign, relocation is not required

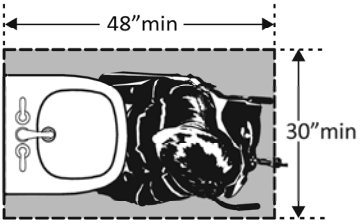
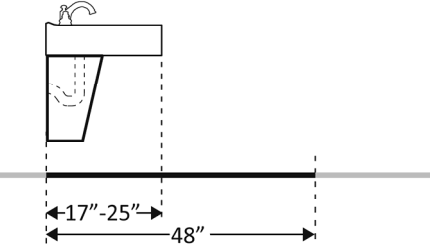
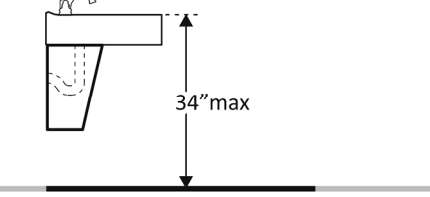
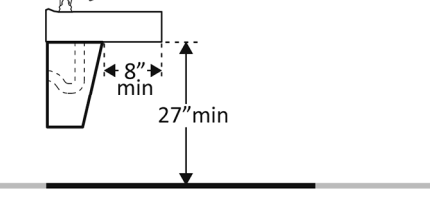
<p>should be on the wall to the right of the right leaf.</p>			<p>Photo #:</p>	
<p>Entrance (2010 Standards – 404)</p>				
<p>3.6 Is the door opening width at least 32 inches clear, between the face of the door and the stop, when the door is open 90 degrees?</p>	<p><input type="checkbox"/> Yes <input type="checkbox"/> No</p> <p>Measurement:</p>		<p>Photo #:</p>	<ul style="list-style-type: none"> • Install offset hinges • Alter the doorway •
<p>3.7 If there is a front approach to the pull side of the door is there at least 18 inches of maneuvering clearance beyond the latch side plus 60 inches clear depth?</p> <p>On both sides of the door, is the floor surface of the maneuvering clearance level (no steeper than 1:48)?</p>	<p><input type="checkbox"/> Yes <input type="checkbox"/> No</p> <p>Measurement:</p> <p><input type="checkbox"/> Yes <input type="checkbox"/> No</p> <p>Measurement:</p>		<p>Photo #:</p>	<ul style="list-style-type: none"> • Remove obstructions • Reconfigure walls • Add automatic door opener <p>See 2010 Standards 404.2.4 for maneuvering clearance requirements on the push side of the door and side approaches to the pull side of the door</p>
<p>3.8 Is the door threshold edge no more than ¼ inch high?</p> <p>Or</p> <p>No more than ¾ inch high if slope is beveled no steeper than 1:2?</p> <p>Note: The first ¼ inch of the threshold may be vertical; the rest must be beveled.</p>	<p><input type="checkbox"/> Yes <input type="checkbox"/> No</p> <p>Measurement:</p> <p><input type="checkbox"/> Yes <input type="checkbox"/> No</p> <p>Measurement:</p>		<p>Photo #:</p>	<ul style="list-style-type: none"> • Remove or replace threshold • •

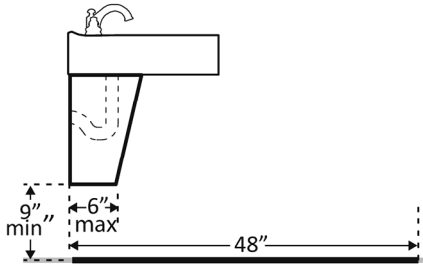
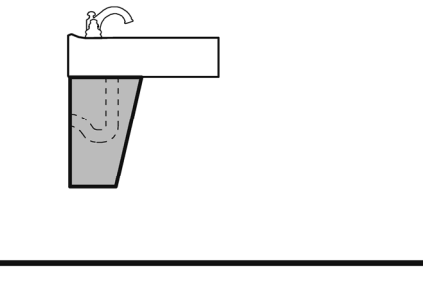
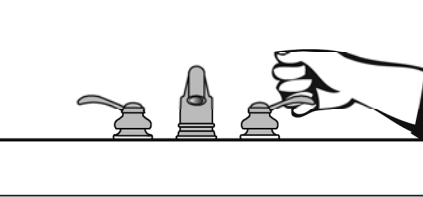
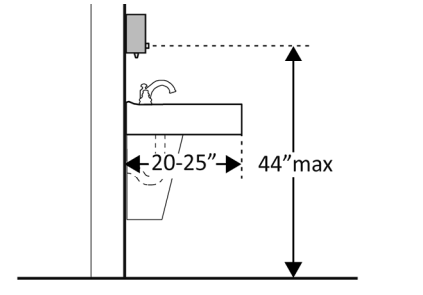
<p>3.9 Is the door equipped with hardware that is operable with one hand and does not require tight grasping, pinching, or twisting of the wrist? Check door handle and lock (if provided).</p>	<p><input type="checkbox"/> Yes <input type="checkbox"/> No</p> <p>Measurement:</p>		<p>Photo #:</p>	<ul style="list-style-type: none"> • Replace knobs or latches with lever or loop handles • Install power-assisted or automatic door openers •
<p>3.10 Are the operable parts of the door hardware mounted no less than 34 inches and no greater than 48 inches above the floor?</p>	<p><input type="checkbox"/> Yes <input type="checkbox"/> No</p> <p>Measurement:</p>		<p>Photo #:</p>	<ul style="list-style-type: none"> • Change hardware height • •
<p>3.11 Can the door be opened easily (5 pounds maximum force)?</p>	<p><input type="checkbox"/> Yes <input type="checkbox"/> No</p> <p>Measurement:</p>		<p>Photo #:</p>	<ul style="list-style-type: none"> • Adjust or replace closers • Install lighter doors • Install power-assisted or automatic door openers
<p>3.12 If the door has a closer, does it take at least 5 seconds to close from an open position of 90 degrees to a position of 12 degrees from the latch?</p>	<p><input type="checkbox"/> Yes <input type="checkbox"/> No</p> <p>Measurement:</p>		<p>Photo #:</p>	<ul style="list-style-type: none"> • Adjust closer • •

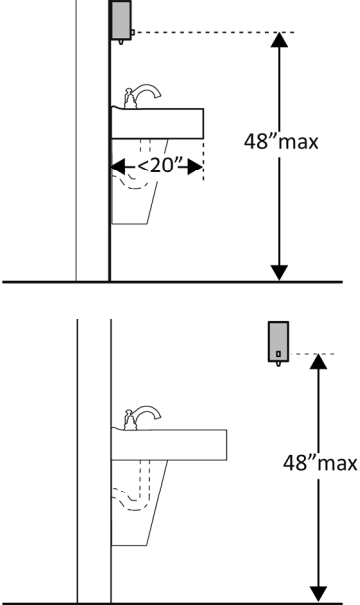
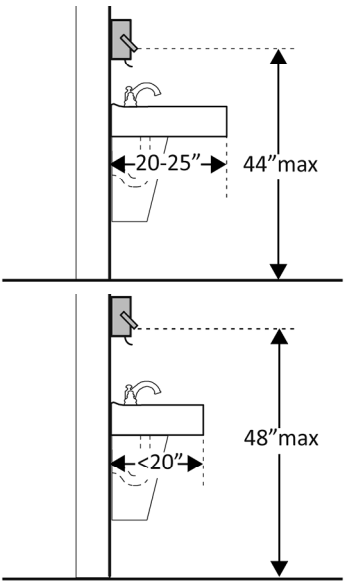
<p>3.13 If there are two doors in a series, e.g. vestibule, is the distance between the doors at least 48 inches plus the width of the doors when swinging into the space?</p>	<p><input type="checkbox"/> Yes <input type="checkbox"/> No</p> <p>Measurement:</p>		<p>• 18 " required</p> <p>Photo #:</p>	<ul style="list-style-type: none"> • Remove inner door • Change door swing •
<p>3.14 If there is a privacy wall and the door swings out, is there at least 24 inches of maneuvering clearance beyond the door latch side and 42 inches to the privacy wall?</p>	<p><input type="checkbox"/> Yes <input type="checkbox"/> No</p> <p>Measurement:</p>		<p>• No Privacy Wall</p> <p>• 29" clearance behind to counter</p> <p>Photo #: 58</p>	<ul style="list-style-type: none"> • Reconfigure space • •

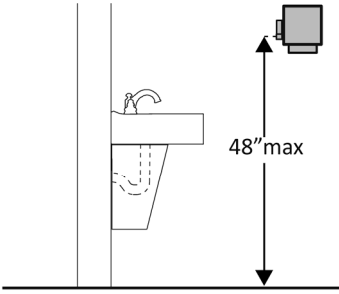
<p>3.15 If there is a privacy wall and the door swings in, is there at least 24 inches of maneuvering clearance beyond the door latch side and at least 48 inches to the privacy wall if there is no door closer or at least 54 inches if there is a door closer?</p>	<p><input type="checkbox"/> Yes <input type="checkbox"/> No</p> <p>Measurement:</p>		<p style="text-align: center; color: red; font-weight: bold;">NA</p> <p>Photo #:</p>	<ul style="list-style-type: none"> • Reconfigure space • •
In the Toilet Room				
<p>3.16 Is there a clear path to at least one of each type of fixture, e.g. lavatory, hand dryer, etc., that is at least 36 inches wide?</p>	<p><input checked="" type="checkbox"/> Yes <input type="checkbox"/> No</p> <p>Measurement:</p>		<p>Photo #:</p>	<ul style="list-style-type: none"> • Remove obstructions • •
<p>3.17 Is there clear floor space available for a person in a wheelchair to turn around, i.e. a circle at least 60 inches in diameter or a T-shaped space within a 60-inch square?*</p>	<p><input checked="" type="checkbox"/> Yes <input type="checkbox"/> No</p> <p>Measurement:</p>		<p>Photo #:</p>	<p>*The door to the toilet room may swing into the required turning space</p> <ul style="list-style-type: none"> • Move or remove partitions, fixtures or objects such as trash cans • •

<p>3.18 In a single user toilet room if the door swings in and over a clear floor space at an accessible fixture, is there a clear floor space at least 30 x 48 inches beyond the swing of the door?</p>	<p><input type="checkbox"/> Yes <input type="checkbox"/> No</p> <p>Measurement:</p>		<p style="text-align: center;">NA</p> <p>Photo #:</p>	<ul style="list-style-type: none"> • Reverse door swing • Alter toilet room •
<p>3.19 If the mirror is over a lavatory or countertop, is the bottom edge of the reflecting surface no higher than 40 inches above the floor? Or If the mirror is not over the lavatory or countertop, is the bottom edge of the reflecting surface no higher than 35 inches above the floor?*</p>	<p><input checked="" type="checkbox"/> Yes <input type="checkbox"/> No</p> <p>Measurement:</p> <p style="text-align: center;">37 1/2"</p> <p><input type="checkbox"/> Yes <input type="checkbox"/> No</p> <p>Measurement:</p>		<p>Photo #: 63</p>	<p>* If installed before 3/15/2012 and the bottom edge of the reflecting surface is no higher than 40 inches above the floor, lowering the mirror to 35 inches is not required</p> <ul style="list-style-type: none"> • Lower the mirror • Add another mirror •
<p>3.20 If there is a coat hook, is it no less than 15 inches and no greater than 48 inches above the floor?</p>	<p><input type="checkbox"/> Yes <input type="checkbox"/> No</p> <p>Measurement:</p>		<p style="text-align: center;">NA</p> <p>Photo #:</p>	<ul style="list-style-type: none"> • Adjust hook • Replace with or provide additional accessible hook •

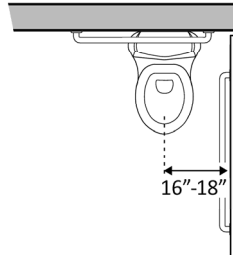
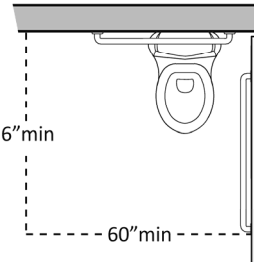
Lavatories (2010 Standards – 606) Note: 2010 Standards refer to sinks in toilet rooms as lavatories.				
<p>3.21 Does at least one lavatory have a clear floor space for a forward approach at least 30 inches wide and 48 inches long?</p>	<p><input checked="" type="checkbox"/> Yes <input type="checkbox"/> No</p> <p>Measurement:</p>		<p>Photo #:</p>	<ul style="list-style-type: none"> • Alter lavatory • Replace lavatory •
<p>3.22 Do no less than 17 inches and no greater than 25 inches of the clear floor space extend under the lavatory so that a person using a wheelchair can get close enough to reach the faucet?</p>	<p><input checked="" type="checkbox"/> Yes <input type="checkbox"/> No</p> <p>Measurement:</p>		<p>Photo #:</p>	<ul style="list-style-type: none"> • Alter lavatory • Replace lavatory •
<p>3.23 Is the front of the lavatory or counter surface, whichever is higher, no more than 34 inches above the floor?</p>	<p><input checked="" type="checkbox"/> Yes <input type="checkbox"/> No</p> <p>Measurement:</p>		<p>Photo #:</p>	<ul style="list-style-type: none"> • Alter lavatory • Replace lavatory •
<p>3.24 Is there at least 27 inches clearance from the floor to the bottom of the lavatory that extends at least 8 inches under the lav for knee clearance?</p>	<p><input type="checkbox"/> Yes <input type="checkbox"/> No</p> <p>Measurement:</p>		<p>Photo #:</p>	<ul style="list-style-type: none"> • Alter lavatory • Replace lavatory •

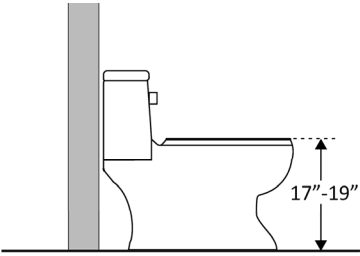
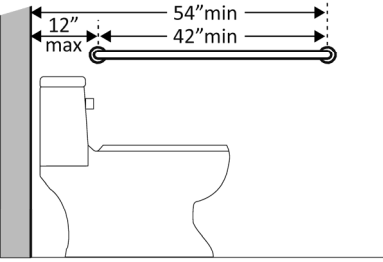
<p>3.25 Is there toe clearance at least 9 inches high? (Space extending greater than 6 inches beyond the available toe clearance at 9 inches above the floor is not considered toe clearance.)</p>	<p><input checked="" type="checkbox"/> Yes <input type="checkbox"/> No</p>		<p>Photo #:</p>	<ul style="list-style-type: none"> • Alter lavatory • Replace lavatory •
<p>3.26 Are pipes below the lavatory insulated or otherwise configured to protect against contact?</p>	<p><input checked="" type="checkbox"/> Yes <input type="checkbox"/> No</p>		<p>Photo #:</p>	<ul style="list-style-type: none"> • Install insulation • Install cover panel •
<p>3.27 Can the faucet be operated without tight grasping, pinching, or twisting of the wrist? Is the force required to activate the faucet no greater than 5 pounds?</p>	<p><input checked="" type="checkbox"/> Yes <input type="checkbox"/> No</p> <p><input type="checkbox"/> Yes <input type="checkbox"/> No</p>		<p>• SENSORS</p> <p>Photo #:</p>	<ul style="list-style-type: none"> • Adjust faucet • Replace faucet •
<p>Soap Dispensers and Hand Dryers (2010 Standards – 603)</p>				
<p>3.28 Are the operable parts of the soap dispenser within one of the following reach ranges: Above lavatories or counters no less than 20 inches and no greater than 25 inches deep: no higher than 44 inches above the floor?</p>	<p><input checked="" type="checkbox"/> Yes <input type="checkbox"/> No</p> <p>Measurement:</p>		<p>• 9" Above Counter</p> <p>• 42" Above Floor</p>	<ul style="list-style-type: none"> • Adjust dispensers • Replace with or provide additional accessible dispensers •

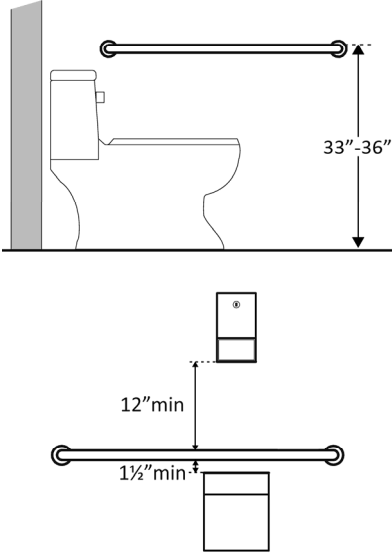
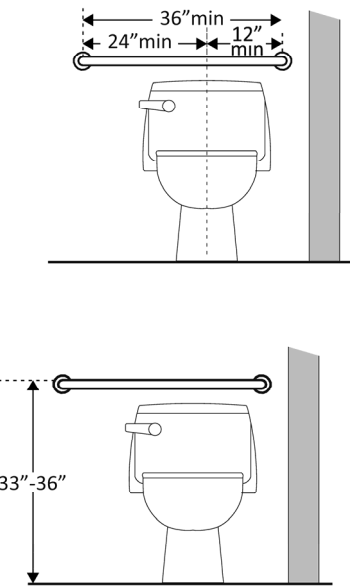
<p>Above lavatories less than 20 inches deep: no higher than 48 inches above the floor?</p> <p>Not over an obstruction: no higher than 48 inches above the floor?</p>	<p><input checked="" type="checkbox"/> Yes <input type="checkbox"/> No</p> <p>Measurement: 43"</p> <p><input type="checkbox"/> Yes <input type="checkbox"/> No</p> <p>Measurement:</p>		<p>Photo #: 64</p>	
<p>3.29 Are the operable parts of the hand dryer or towel dispenser within one of the following reach ranges:</p> <p>Above lavatories or counters no less than 20 inches and no greater than 25 inches deep: no higher than 44 inches above the floor?</p> <p>Above lavatories less than 20 inches deep: no higher than 48 inches above the floor?</p> <p>Not over an obstruction: no</p>	<p><input type="checkbox"/> Yes <input type="checkbox"/> No</p> <p>Measurement:</p> <p><input type="checkbox"/> Yes <input type="checkbox"/> No</p> <p>Measurement:</p> <p><input type="checkbox"/> Yes <input type="checkbox"/> No</p>		<p>NA</p>	<ul style="list-style-type: none"> • Adjust dispensers • Replace with or provide additional accessible dispensers •

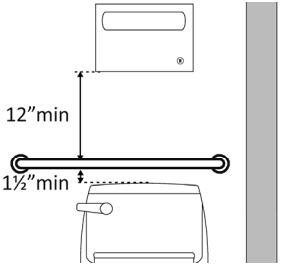
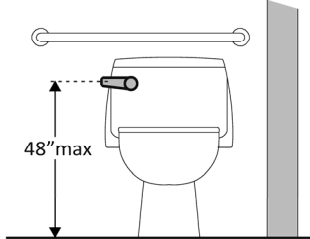
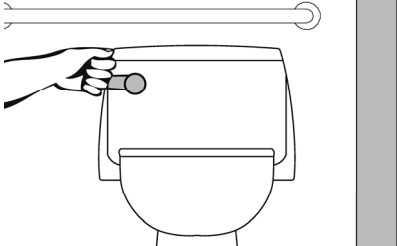
<p>higher than 48 inches above the floor?</p> <p>Can the operable parts of the hand dryer or towel dispenser be operated without tight grasping, pinching or twisting of the wrist?</p> <p>Is the force required to activate the hand dryer or towel dispenser no greater than 5 pounds?</p>	<p>Measurement:</p> <p><input type="checkbox"/> Yes <input type="checkbox"/> No</p> <p><input checked="" type="checkbox"/> Yes <input type="checkbox"/> No</p> <p>Measurement:</p>		<p>• 45"</p> <p>Photo #:</p>	
--	--	--	------------------------------	--

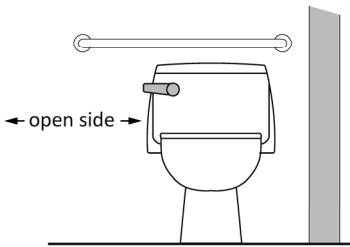
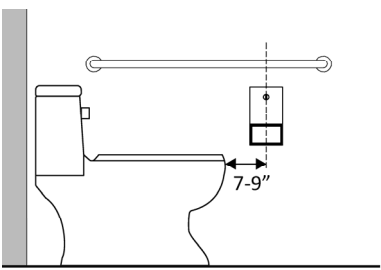
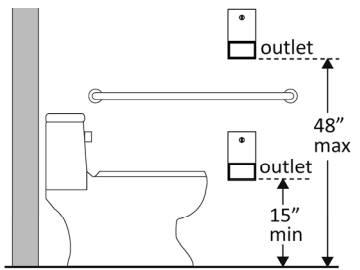
Water Closets in Single-User Toilet Rooms and Compartments (Stalls) (2010 Standards – 603 & 609) Note: 2010 Standards refer to toilets as water closets.

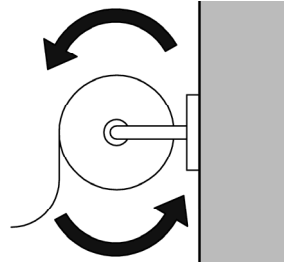
<p>3.30 Is the centerline of the water closet no less than 16 inches and no greater than 18 inches from the side wall or partition?</p>	<p><input checked="" type="checkbox"/> Yes <input type="checkbox"/> No</p> <p>Measurement:</p> <p>18"</p>		<p>Photo #: 80</p>	<ul style="list-style-type: none"> • Move toilet • Replace toilet • Move partition •
<p>3.31 Is clearance provided around the water closet measuring at least 60 inches from the side wall and at least 56 inches from the rear wall?*</p>	<p><input checked="" type="checkbox"/> Yes <input type="checkbox"/> No</p> <p>Measurement:</p>		<ul style="list-style-type: none"> • 60" from rear wall • 70" from side wall <p>Photo #: 76</p>	<p>* If constructed before 3/15/12, clearances around water closets in single user toilet rooms can be 48 inches wide by 66 inches long or 48 inches wide by 56 inches long (depending on the approach to the water closet, see 1991 Standards Figure 28) and the lavatory may overlap</p>

				<p>that clearance if the door to the room does not swing into the required clearances at fixtures (such as lavatories, water closet and urinals) and the edge of the lavatory is at least 18 inches from the centerline of the water closet</p> <ul style="list-style-type: none"> Alter room/compartment for clearance
<p>3.32 Is the height of the water closet no less than 17 inches and no greater than 19 inches above the floor measured to the top of the seat?</p>	<p><input checked="" type="checkbox"/> Yes <input type="checkbox"/> No</p> <p>Measurement:</p>		<ul style="list-style-type: none"> 17" height <p>Photo #: 81</p>	<ul style="list-style-type: none"> Adjust toilet height Replace toilet
<p>3.33 Is there a grab bar at least 42 inches long on the side wall?</p> <p>Is it located no more than 12 inches from the rear wall?</p> <p>Does it extend at least 54 inches from the rear wall?</p>	<p><input checked="" type="checkbox"/> Yes <input type="checkbox"/> No</p> <p>Measurement:</p> <p><input checked="" type="checkbox"/> Yes <input type="checkbox"/> No</p> <p>Measurement:</p> <p><input type="checkbox"/> Yes <input checked="" type="checkbox"/> No</p> <p>Measurement:</p>		<ul style="list-style-type: none"> 42 " grab bar 10 ½" from rear wall Center line 34" above finished floor 	<ul style="list-style-type: none"> Install grab bar Relocate grab bar Relocate objects

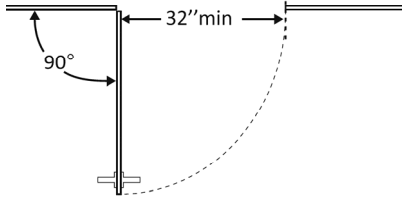
<p>Is it mounted no less than 33 inches and no greater than 36 inches above the floor to the top of the gripping surface?</p> <p>Is there at least 12 inches clearance between the grab bar and protruding objects above?*</p> <p>Is there at least 1½ inches clearance between the grab bar and projecting objects below?*</p> <p>Is the space between the wall and the grab bar 1 ½ inches?</p>	<p><input checked="" type="checkbox"/> Yes <input type="checkbox"/> No Measurement:</p> <p><input type="checkbox"/> Yes <input type="checkbox"/> No Measurement:</p> <p><input type="checkbox"/> Yes <input type="checkbox"/> No Measurement:</p> <p><input type="checkbox"/> Yes <input type="checkbox"/> No Measurement:</p>		<p>• Mounted 34 ½"</p> <p>Photo #: 82</p>	<p>* If constructed before 3/15/2012 grab bars do not need to be relocated; there are no space requirements above and below grab bars in the 1991 Standards</p>
<p>3.34 Is there a grab bar at least 36 inches long on the rear wall?</p> <p>Does it extend at least 12 inches from the centerline of the water closet on one side (side wall)?</p> <p>Does it extend at least 24 inches on the other (open) side?</p> <p>Is it mounted no less than 33 inches and no greater than 36 inches above the floor to the top of the gripping surface?</p>	<p><input checked="" type="checkbox"/> Yes <input type="checkbox"/> No Measurement:</p> <p><input checked="" type="checkbox"/> Yes <input type="checkbox"/> No Measurement:</p> <p><input checked="" type="checkbox"/> Yes <input type="checkbox"/> No Measurement:</p> <p><input type="checkbox"/> Yes <input type="checkbox"/> No Measurement:</p>		<p>• Grab Bar 36"</p> <p>Photo #: 19</p> <p>• Mounted 33 ½"</p> <p>Photo #: 81</p>	<ul style="list-style-type: none"> • Install grab bar • Relocate grab bar • Relocate objects •

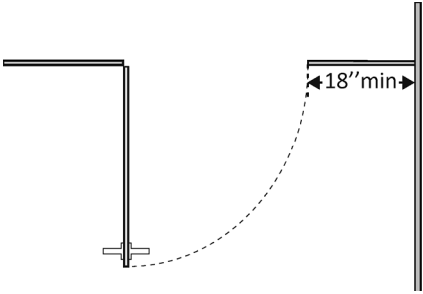
<p>Are there at least 12 inches clearance between the grab bar and protruding objects above?*</p> <p>Are there at least 1½ inches clearance between the grab bar and projecting objects below?*</p> <p>Is the space between the wall and the grab bar 1 ½ inches?</p>	<p><input type="checkbox"/> Yes <input type="checkbox"/> No Measurement:</p> <p><input type="checkbox"/> Yes <input type="checkbox"/> No Measurement:</p> <p><input type="checkbox"/> Yes <input type="checkbox"/> No Measurement:</p>		<p style="text-align: center; color: red; font-weight: bold;">NA</p> <p>Photo #:</p>	<p>* If constructed before 3/15/2012 grab bars do not need to be relocated; there are no space requirements above and below grab bars in the 1991 Standards</p>
<p>3.35 If the flush control is hand operated, is the operable part located no higher than 48 inches above the floor?</p>	<p><input type="checkbox"/> Yes <input type="checkbox"/> No Measurement:</p>		<p style="text-align: center; color: red; font-weight: bold;">NA</p> <p>Photo #:</p>	<ul style="list-style-type: none"> • Move control • Install sensor with override button no higher than 48 inches •
<p>3.36 If the flush control is hand operated, can it be operated with one hand and without tight grasping, pinching, or twisting of the wrist?</p> <p>Is the force required to activate the flush control no greater than 5 pounds?</p>	<p><input type="checkbox"/> Yes <input type="checkbox"/> No Measurement:</p> <p><input type="checkbox"/> Yes <input type="checkbox"/> No Measurement:</p>		<p style="text-align: center; color: red; font-weight: bold;">NA</p> <p>Photo #:</p>	<ul style="list-style-type: none"> • Change control • Adjust control •

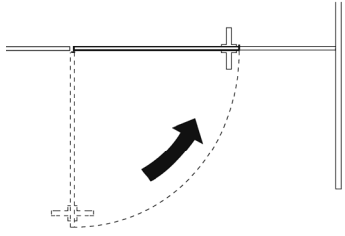
<p>3.37 Is the flush control on the open side of the water closet?</p>	<p><input type="checkbox"/> Yes <input type="checkbox"/> No</p>		<p style="text-align: center; color: red; font-weight: bold;">NA</p> <p>Photo #:</p>	<ul style="list-style-type: none"> • Move control • •
<p>3.38 Is the toilet paper dispenser located no less than 7 inches and no greater than 9 inches from the front of the water closet to the centerline of the dispenser?*</p>	<p><input type="checkbox"/> Yes <input checked="" type="checkbox"/> No</p> <p>Measurement:</p>		<p>Photo #: 87</p>	<p>* If constructed before 3/15/2012 dispenser does not need to be relocated if it is within reach from the water closet seat; the 1991 Standards do not specify distance from the front of the water closet</p> <ul style="list-style-type: none"> • Relocate dispenser • •
<p>3.39 Is the outlet of the dispenser:</p> <p>Located no less than 15 inches and no greater than 48 inches above the floor?</p> <p>Not located behind grab bars?</p>	<p><input type="checkbox"/> Yes <input checked="" type="checkbox"/> No</p> <p>Measurement:</p> <p><input type="checkbox"/> Yes <input checked="" type="checkbox"/> No</p>		<p>Photo #: 87</p>	<ul style="list-style-type: none"> • Relocate dispenser • •

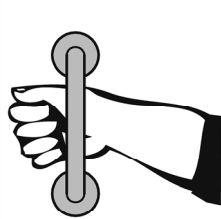
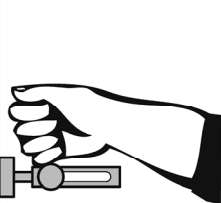
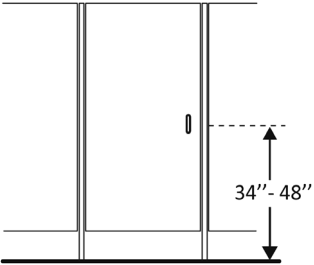
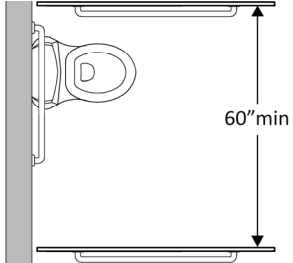
<p>3.40 Does the dispenser allow continuous paper flow?</p>	<p><input checked="" type="checkbox"/> Yes <input type="checkbox"/> No</p>		<p>Photo #:</p>	<ul style="list-style-type: none"> • Adjust dispenser • Replace dispenser •
--	--	---	-----------------	--

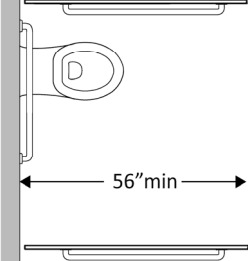
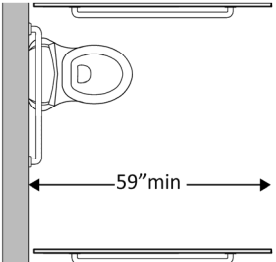
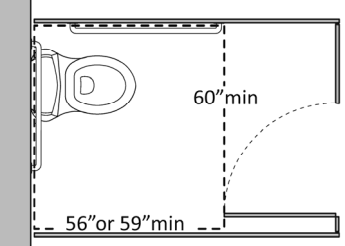
Toilet Compartments (Stalls) (2010 Standards – 604)

<p>3.41 Is the door opening width at least 32 inches clear, between the face of the door and the stop, when the door is open 90 degrees?</p>	<p><input checked="" type="checkbox"/> Yes <input type="checkbox"/> No</p> <p>Measurement:</p>		<p>Photo #:</p>	<ul style="list-style-type: none"> • Widen door width • •
---	--	--	-----------------	--

<p>3.42 If there is a front approach to the pull side of the door, is there at least 18 inches of maneuvering clearance beyond the latch side plus 60 inches clear depth?*</p>	<p><input type="checkbox"/> Yes <input type="checkbox"/> No</p> <p>Measurement:</p>		<p>Photo #:</p>	<p>*See 2010 Standards 604.8.1.2 Doors for maneuvering clearance requirements on the push side of the door and side approaches to the pull side of the door</p> <ul style="list-style-type: none"> • Remove obstructions •
---	---	---	-----------------	--

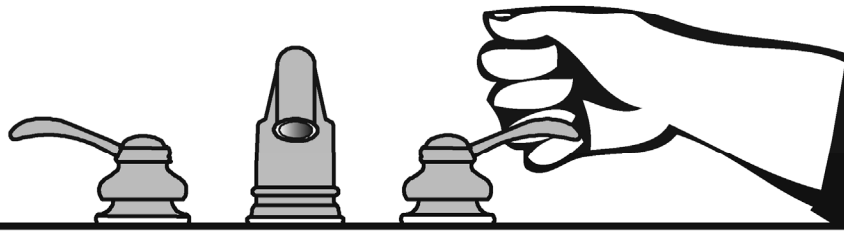
<p>3.43 Is the door self-closing?</p>	<p><input type="checkbox"/> Yes <input type="checkbox"/> No</p>		<p>Photo #:</p>	<ul style="list-style-type: none"> • Add closer • Replace door •
--	---	--	-----------------	---

<p>3.44 Are there door pulls on both sides of the door that are operable with one hand and do not require tight grasping pinching or twisting of the wrist?*</p>	<p><input checked="" type="checkbox"/> Yes <input type="checkbox"/> No</p>		<p>Photo #: 91</p>	<p>* If constructed before 3/15/2012 door pulls do not need to be added; door pulls are not required in the 1991 Standards</p> <ul style="list-style-type: none"> • Replace hardware • •
<p>3.45 Is the lock operable with one hand and without tight grasping, pinching or twisting of the wrist?</p>	<p><input checked="" type="checkbox"/> Yes <input type="checkbox"/> No</p>		<p>Photo #: 89</p>	<ul style="list-style-type: none"> • Replace lock • •
<p>3.46 Are the operable parts of the door hardware mounted no less than 34 inches and no greater than 48 inches above the floor?</p>	<p><input checked="" type="checkbox"/> Yes <input type="checkbox"/> No</p> <p>Measurement:</p> <p>41 1/2"</p>		<p>Photo #: 89</p>	<ul style="list-style-type: none"> • Relocate hardware • •
<p>3.47 Is the compartment at least 60 inches wide?</p>	<p><input type="checkbox"/> Yes <input type="checkbox"/> No</p> <p>Measurement:</p>		<p>Photo #:</p>	<ul style="list-style-type: none"> • Widen compartment • •

<p>3.48 If the water closet is wall hung, is the compartment at least 56 inches deep?</p>	<p><input type="checkbox"/> Yes <input type="checkbox"/> No</p> <p>Measurement:</p>		<p>Photo #:</p>	<ul style="list-style-type: none"> • Widen compartment • •
<p>3.49 If the water closet is floor mounted, is the compartment at least 59 inches deep?</p>	<p><input type="checkbox"/> Yes <input type="checkbox"/> No</p> <p>Measurement:</p>		<p>Photo #:</p>	<ul style="list-style-type: none"> • Alter compartment • •
<p>3.50 If the door swings in, is the minimum required compartment area provided beyond the swing of the door (60 inches x 56 inches if water closet is wall hung or 59 inches if water closet is floor mounted)?</p>	<p><input type="checkbox"/> Yes <input type="checkbox"/> No</p> <p>Measurement:</p>		<p>Photo #:</p>	<ul style="list-style-type: none"> • Reverse door swing • Alter compartment •
	<p><input type="checkbox"/> Yes <input type="checkbox"/> No</p>		<p>Photo #:</p>	<ul style="list-style-type: none"> • • •
	<p><input type="checkbox"/> Yes <input type="checkbox"/> No</p>		<p>Photo #:</p>	<ul style="list-style-type: none"> • • •

The ADA Checklist for Readily Achievable Barrier Removal

Priority 3 – Men’s Toilet Rooms



Project **SDDOT Rest Area Improvements**
FHU Reference Number 13-039-01
TSP Project Number 03120855

Building **TILFORD WEST**

Location **90 W., MRM 41**

Date **09-19-2013 (Inspection)**

Surveyors **Timothy Roach, AIA**
Todd Schultz, PE

Contact Information **TSP – (605) 343-6102**



When toilet rooms are open to the public they should be accessible to people with disabilities.



Institute for Human Centered Design
www.HumanCenteredDesign.org
November 2011



ADA National Network
Questions on the ADA 800-949-4232 voice/tty
www.ADAchecklist.org

Priority 3 – Toilet Rooms		Comments	Possible Solutions
<p>3.1 If toilet rooms are available to the public, is at least one toilet room accessible? (Either one for each sex, or one unisex.)</p> <p><input checked="" type="checkbox"/> Yes <input type="checkbox"/> No</p>		Photo #:	<ul style="list-style-type: none"> Reconfigure toilet rooms Combine toilet rooms to create one unisex accessible toilet room
<p>3.2 Are there signs at inaccessible toilet rooms that give directions to accessible toilet rooms?</p> <p><input type="checkbox"/> Yes <input type="checkbox"/> No</p>		<p>Photo #:</p> <p style="text-align: center; color: red;">NA</p>	<ul style="list-style-type: none"> Install signs
<p>3.3 If not all toilet rooms are accessible, is there a sign at the accessible toilet room with the International Symbol of Accessibility?</p> <p><input type="checkbox"/> Yes <input type="checkbox"/> No</p>		<p>Photo #:</p> <p style="text-align: center; color: red;">NA</p>	<ul style="list-style-type: none"> Install sign
<p>Accessible Route (2010 Standards – Chapter 4)</p>			
<p>3.4 Is there a route to the accessible toilet room(s) that does not include the use of stairs?</p> <p><input checked="" type="checkbox"/> Yes <input type="checkbox"/> No</p> <p>Is the route accessible? (See Priority 2 Interior Accessible Route for specifics.)</p> <p><input type="checkbox"/> Yes <input checked="" type="checkbox"/> No</p>		<p>Photo #:</p> <ul style="list-style-type: none"> Insufficient clearance @ door 	<ul style="list-style-type: none"> Alter route

Signs at Toilet Rooms (2010 Standards – 703)

3.5 Do text characters contrast with their backgrounds?

Yes No

Are text characters raised?

Yes No

Is there Braille?

Yes No

Is the sign mounted:
On the wall on the latch side of the door?

Yes No

Note:

Signs are permitted on the push side of doors with closers and without hold-open devices.

With clear floor space beyond the arc of the door swing and 45-degree open position, at least 18 x 18 inches centered on the tactile characters? *

Yes No

Measurement:

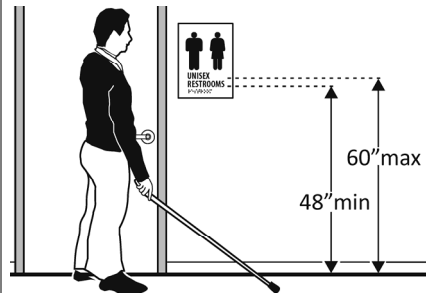
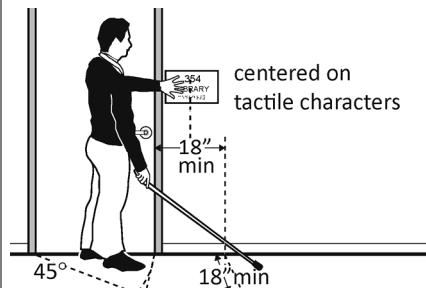
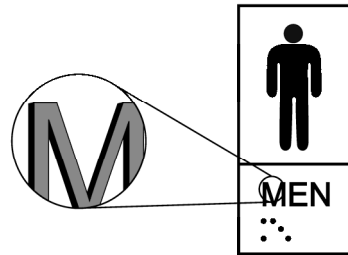
So the baseline of the lowest character is at least 48 inches above the floor and the baseline of the highest character is no more than 60 inches above the floor? *

Yes No

Measurement:

Note:

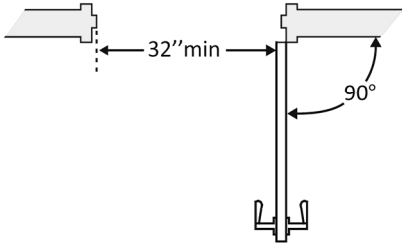
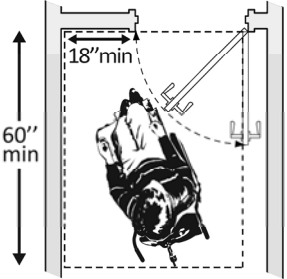
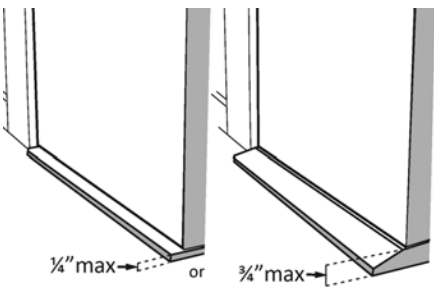
If the sign is at double doors with one active leaf, the sign should be on the inactive leaf; if both leaves are active, the sign

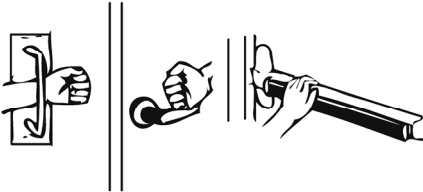
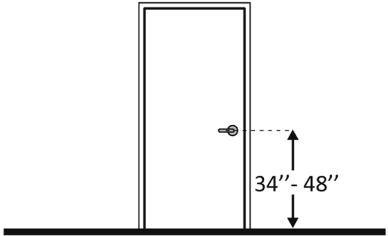

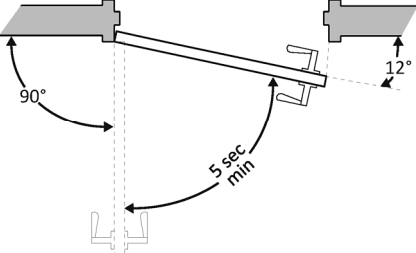


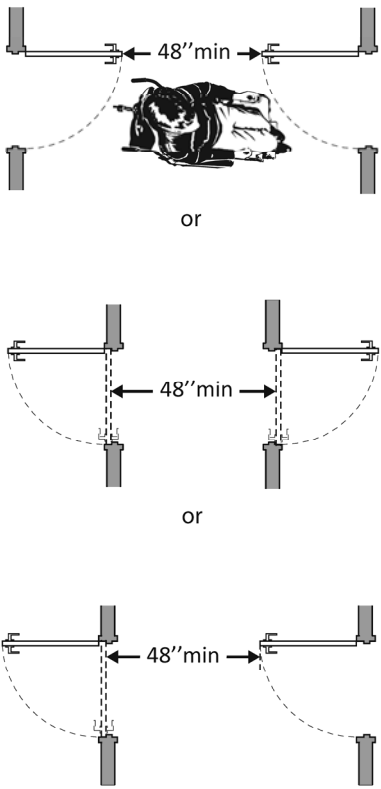
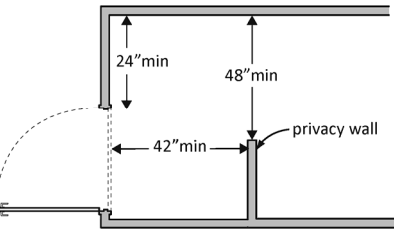
- Install tactile sign
- Relocate sign
-

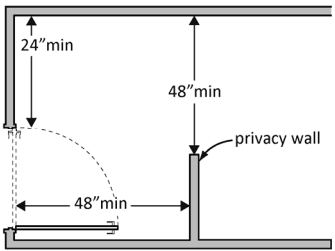

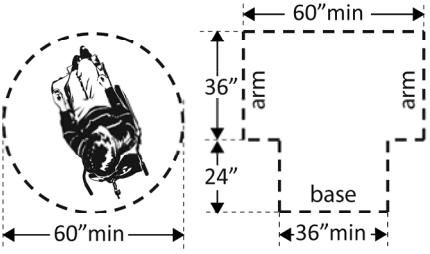
*If constructed before 3/15/2010 and a person may approach within 3 inches of the sign without encountering protruding objects or standing within the door swing, relocation not required

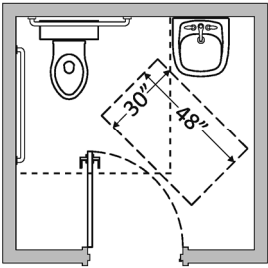
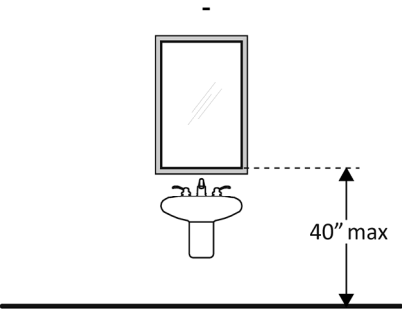
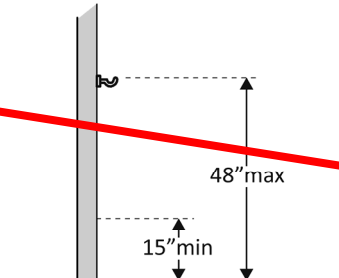
*If constructed before 3/15/2012 and mounted no higher than 60 inches to the centerline of the sign, relocation is not required

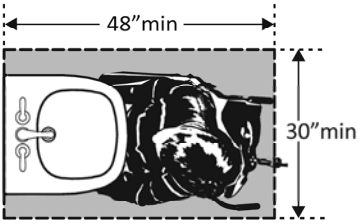
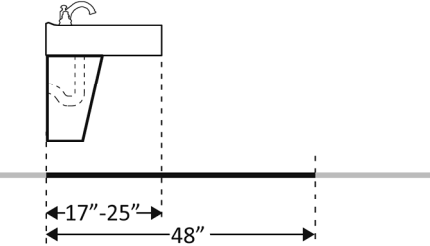
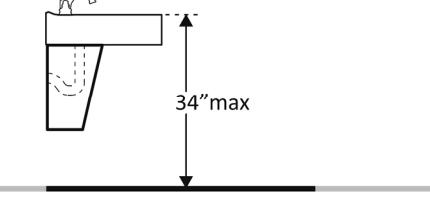
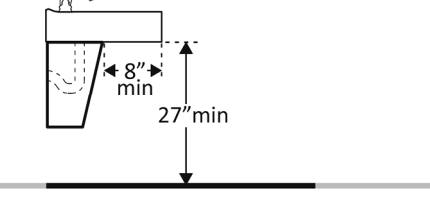
<p>should be on the wall to the right of the right leaf.</p>			<p>Photo #:</p>	
<p>Entrance (2010 Standards – 404)</p>				
<p>3.6 Is the door opening width at least 32 inches clear, between the face of the door and the stop, when the door is open 90 degrees?</p>	<p><input type="checkbox"/> Yes <input type="checkbox"/> No</p> <p>Measurement:</p>		<p>Photo #:</p>	<ul style="list-style-type: none"> • Install offset hinges • Alter the doorway •
<p>3.7 If there is a front approach to the pull side of the door is there at least 18 inches of maneuvering clearance beyond the latch side plus 60 inches clear depth?</p> <p>On both sides of the door, is the floor surface of the maneuvering clearance level (no steeper than 1:48)?</p>	<p><input type="checkbox"/> Yes <input type="checkbox"/> No</p> <p>Measurement:</p> <p><input type="checkbox"/> Yes <input type="checkbox"/> No</p> <p>Measurement:</p>		<p>Photo #:</p>	<ul style="list-style-type: none"> • Remove obstructions • Reconfigure walls • Add automatic door opener <p>See 2010 Standards 404.2.4 for maneuvering clearance requirements on the push side of the door and side approaches to the pull side of the door</p>
<p>3.8 Is the door threshold edge no more than ¼ inch high?</p> <p>Or</p> <p>No more than ¾ inch high if slope is beveled no steeper than 1:2?</p> <p>Note: The first ¼ inch of the threshold may be vertical; the rest must be beveled.</p>	<p><input type="checkbox"/> Yes <input type="checkbox"/> No</p> <p>Measurement:</p> <p><input type="checkbox"/> Yes <input type="checkbox"/> No</p> <p>Measurement:</p>		<p>Photo #:</p>	<ul style="list-style-type: none"> • Remove or replace threshold • •

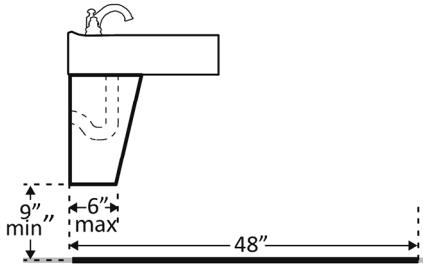
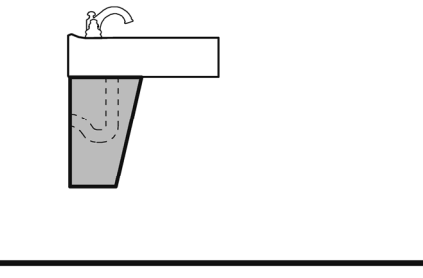
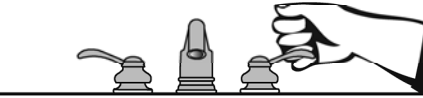
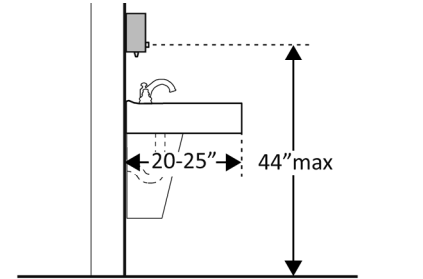
<p>3.9 Is the door equipped with hardware that is operable with one hand and does not require tight grasping, pinching, or twisting of the wrist? Check door handle and lock (if provided).</p>	<p><input type="checkbox"/> Yes <input type="checkbox"/> No</p> <p>Measurement:</p>		<p>Photo #:</p>	<ul style="list-style-type: none"> • Replace knobs or latches with lever or loop handles • Install power-assisted or automatic door openers •
<p>3.10 Are the operable parts of the door hardware mounted no less than 34 inches and no greater than 48 inches above the floor?</p>	<p><input type="checkbox"/> Yes <input type="checkbox"/> No</p> <p>Measurement:</p>		<p>Photo #:</p>	<ul style="list-style-type: none"> • Change hardware height • •
<p>3.11 Can the door be opened easily (5 pounds maximum force)?</p>	<p><input type="checkbox"/> Yes <input type="checkbox"/> No</p> <p>Measurement:</p>		<p>Photo #:</p>	<ul style="list-style-type: none"> • Adjust or replace closers • Install lighter doors • Install power-assisted or automatic door openers
<p>3.12 If the door has a closer, does it take at least 5 seconds to close from an open position of 90 degrees to a position of 12 degrees from the latch?</p>	<p><input type="checkbox"/> Yes <input type="checkbox"/> No</p> <p>Measurement:</p>		<p>Photo #:</p>	<ul style="list-style-type: none"> • Adjust closer • •

<p>3.13 If there are two doors in a series, e.g. vestibule, is the distance between the doors at least 48 inches plus the width of the doors when swinging into the space?</p>	<p><input type="checkbox"/> Yes <input type="checkbox"/> No</p> <p>Measurement:</p>	 <p>48" min</p> <p>or</p> <p>48" min</p> <p>or</p> <p>48" min</p>	<p>• 18" Required</p> <p>Photo #:</p>	<ul style="list-style-type: none"> • Remove inner door • Change door swing •
<p>3.14 If there is a privacy wall and the door swings out, is there at least 24 inches of maneuvering clearance beyond the door latch side and 42 inches to the privacy wall?</p>	<p><input type="checkbox"/> Yes <input type="checkbox"/> No</p> <p>Measurement:</p>	 <p>24" min</p> <p>48" min</p> <p>42" min</p> <p>privacy wall</p>	<p>• No Privacy Wall</p> <p>• 29" clearance behind to counter</p> <p>Photo #: 58</p>	<ul style="list-style-type: none"> • Reconfigure space • •

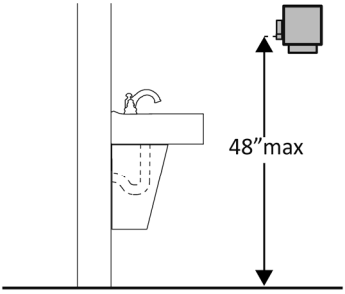
<p>3.15 If there is a privacy wall and the door swings in, is there at least 24 inches of maneuvering clearance beyond the door latch side and at least 48 inches to the privacy wall if there is no door closer or at least 54 inches if there is a door closer?</p>	<p><input type="checkbox"/> Yes <input type="checkbox"/> No</p> <p>Measurement:</p>		<p style="text-align: center; color: red; font-weight: bold;">NA</p> <p>Photo #:</p>	<ul style="list-style-type: none"> • Reconfigure space • •
In the Toilet Room				
<p>3.16 Is there a clear path to at least one of each type of fixture, e.g. lavatory, hand dryer, etc., that is at least 36 inches wide?</p>	<p><input checked="" type="checkbox"/> Yes <input type="checkbox"/> No</p> <p>Measurement:</p>		<p>Photo #:</p>	<ul style="list-style-type: none"> • Remove obstructions • •
<p>3.17 Is there clear floor space available for a person in a wheelchair to turn around, i.e. a circle at least 60 inches in diameter or a T-shaped space within a 60-inch square?*</p>	<p><input checked="" type="checkbox"/> Yes <input type="checkbox"/> No</p> <p>Measurement:</p>		<p>Photo #:</p>	<p>*The door to the toilet room may swing into the required turning space</p> <ul style="list-style-type: none"> • Move or remove partitions, fixtures or objects such as trash cans • •

<p>3.18 In a single user toilet room if the door swings in and over a clear floor space at an accessible fixture, is there a clear floor space at least 30 x 48 inches beyond the swing of the door?</p>	<p><input type="checkbox"/> Yes <input type="checkbox"/> No</p> <p>Measurement:</p>		<p style="text-align: center; color: red; font-weight: bold;">NA</p> <p>Photo #:</p>	<ul style="list-style-type: none"> • Reverse door swing • Alter toilet room •
<p>3.19 If the mirror is over a lavatory or countertop, is the bottom edge of the reflecting surface no higher than 40 inches above the floor? Or If the mirror is not over the lavatory or countertop, is the bottom edge of the reflecting surface no higher than 35 inches above the floor?*</p>	<p><input checked="" type="checkbox"/> Yes <input type="checkbox"/> No</p> <p>Measurement:</p> <p style="text-align: center; color: red; font-weight: bold;">37 ½"</p> <p><input type="checkbox"/> Yes <input type="checkbox"/> No</p> <p>Measurement:</p>		<p>Photo #: 63</p>	<p>* If installed before 3/15/2012 and the bottom edge of the reflecting surface is no higher than 40 inches above the floor, lowering the mirror to 35 inches is not required</p> <ul style="list-style-type: none"> • Lower the mirror • Add another mirror •
<p>3.20 If there is a coat hook, is it no less than 15 inches and no greater than 48 inches above the floor?</p>	<p><input type="checkbox"/> Yes <input type="checkbox"/> No</p> <p>Measurement:</p>		<p>Photo #:</p>	<ul style="list-style-type: none"> • Adjust hook • Replace with or provide additional accessible hook •

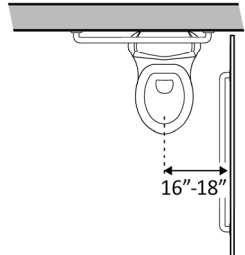
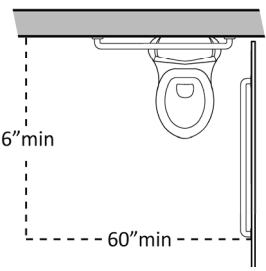
Lavatories (2010 Standards – 606) Note: 2010 Standards refer to sinks in toilet rooms as lavatories.				
<p>3.21 Does at least one lavatory have a clear floor space for a forward approach at least 30 inches wide and 48 inches long?</p>	<p><input checked="" type="checkbox"/> Yes <input type="checkbox"/> No</p> <p>Measurement:</p>		<p>Photo #:</p>	<ul style="list-style-type: none"> • Alter lavatory • Replace lavatory •
<p>3.22 Do no less than 17 inches and no greater than 25 inches of the clear floor space extend under the lavatory so that a person using a wheelchair can get close enough to reach the faucet?</p>	<p><input checked="" type="checkbox"/> Yes <input type="checkbox"/> No</p> <p>Measurement:</p>		<p>Photo #:</p>	<ul style="list-style-type: none"> • Alter lavatory • Replace lavatory •
<p>3.23 Is the front of the lavatory or counter surface, whichever is higher, no more than 34 inches above the floor?</p>	<p><input checked="" type="checkbox"/> Yes <input type="checkbox"/> No</p> <p>Measurement:</p>		<p>Photo #:</p>	<ul style="list-style-type: none"> • Alter lavatory • Replace lavatory •
<p>3.24 Is there at least 27 inches clearance from the floor to the bottom of the lavatory that extends at least 8 inches under the lav for knee clearance?</p>	<p><input type="checkbox"/> Yes <input checked="" type="checkbox"/> No</p> <p>Measurement:</p>		<p>Photo #:</p>	<ul style="list-style-type: none"> • Alter lavatory • Replace lavatory •

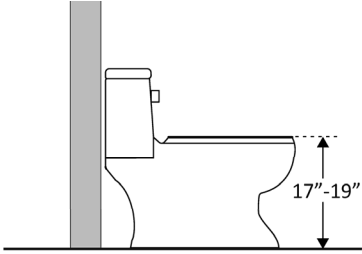
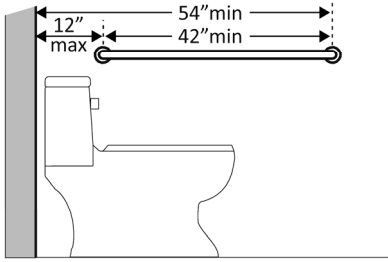
<p>3.25 Is there toe clearance at least 9 inches high? (Space extending greater than 6 inches beyond the available toe clearance at 9 inches above the floor is not considered toe clearance.)</p>	<p><input checked="" type="checkbox"/> Yes <input type="checkbox"/> No</p>		<p>Photo #:</p>	<ul style="list-style-type: none"> • Alter lavatory • Replace lavatory •
<p>3.26 Are pipes below the lavatory insulated or otherwise configured to protect against contact?</p>	<p><input checked="" type="checkbox"/> Yes <input type="checkbox"/> No</p>		<p>Photo #:</p>	<ul style="list-style-type: none"> • Install insulation • Install cover panel •
<p>3.27 Can the faucet be operated without tight grasping, pinching, or twisting of the wrist? Is the force required to activate the faucet no greater than 5 pounds?</p>	<p><input checked="" type="checkbox"/> Yes <input type="checkbox"/> No</p> <p><input type="checkbox"/> Yes <input type="checkbox"/> No</p>		<p>• Sensors</p> <p>Photo #:</p>	<ul style="list-style-type: none"> • Adjust faucet • Replace faucet •
<p>Soap Dispensers and Hand Dryers (2010 Standards – 603)</p>				
<p>3.28 Are the operable parts of the soap dispenser within one of the following reach ranges: Above lavatories or counters no less than 20 inches and no greater than 25 inches deep; no higher than 44 inches above the floor?</p>	<p><input checked="" type="checkbox"/> Yes <input type="checkbox"/> No</p> <p>Measurement:</p>		<ul style="list-style-type: none"> • 9" Above Counter • 42" Above Floor 	<ul style="list-style-type: none"> • Adjust dispensers • Replace with or provide additional accessible dispensers •

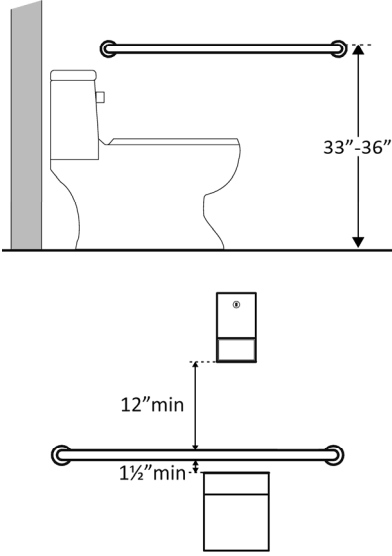
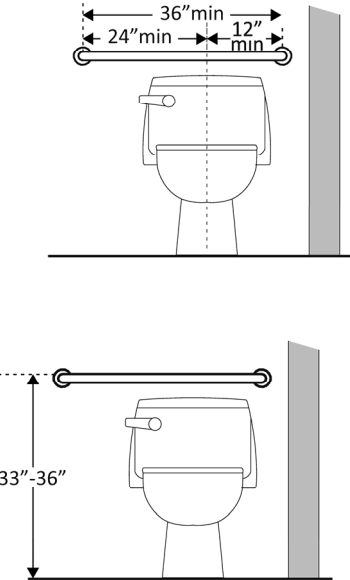
<p>Above lavatories less than 20 inches deep: no higher than 48 inches above the floor?</p> <p>Not over an obstruction: no higher than 48 inches above the floor?</p>	<p><input checked="" type="checkbox"/> Yes <input type="checkbox"/> No</p> <p>Measurement: 43"</p> <p><input type="checkbox"/> Yes <input type="checkbox"/> No</p> <p>Measurement:</p>		<p>Photo #: 64</p>	
<p>3.29 Are the operable parts of the hand dryer or towel dispenser within one of the following reach ranges:</p> <p>Above lavatories or counters no less than 20 inches and no greater than 25 inches deep: no higher than 44 inches above the floor?</p> <p>Above lavatories less than 20 inches deep: no higher than 48 inches above the floor?</p> <p>Not over an obstruction: no</p>	<p><input type="checkbox"/> Yes <input type="checkbox"/> No</p> <p>Measurement:</p> <p><input type="checkbox"/> Yes <input type="checkbox"/> No</p> <p>Measurement:</p> <p><input type="checkbox"/> Yes <input type="checkbox"/> No</p>		<p>NA</p>	<ul style="list-style-type: none"> • Adjust dispensers • Replace with or provide additional accessible dispensers •

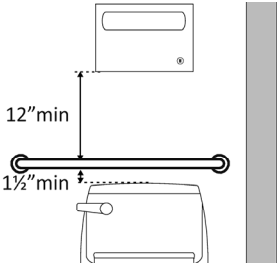
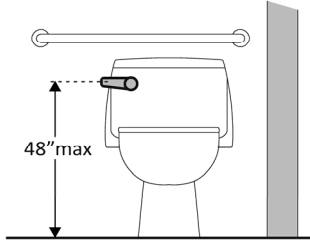
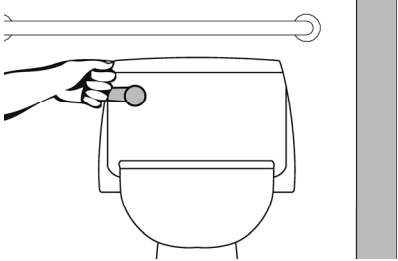
<p>higher than 48 inches above the floor?</p> <p>Can the operable parts of the hand dryer or towel dispenser be operated without tight grasping, pinching or twisting of the wrist?</p> <p>Is the force required to activate the hand dryer or towel dispenser no greater than 5 pounds?</p>	<p>Measurement:</p> <p><input type="checkbox"/> Yes <input type="checkbox"/> No</p> <p><input checked="" type="checkbox"/> Yes <input type="checkbox"/> No</p> <p>Measurement:</p>		<p>• 45"</p> <p>Photo #:</p>	
--	--	--	------------------------------	--

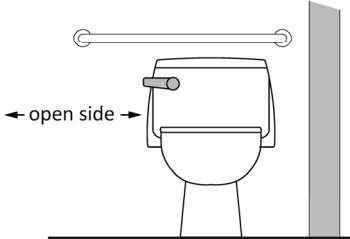
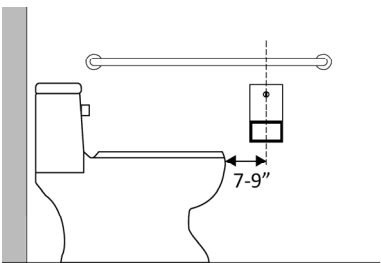
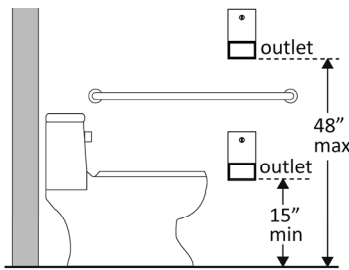
Water Closets in Single-User Toilet Rooms and Compartments (Stalls) (2010 Standards – 603 & 609) Note: 2010 Standards refer to toilets as water closets.

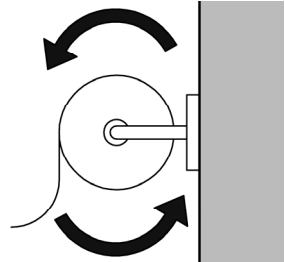
<p>3.30 Is the centerline of the water closet no less than 16 inches and no greater than 18 inches from the side wall or partition?</p>	<p><input type="checkbox"/> Yes <input checked="" type="checkbox"/> No</p> <p>Measurement:</p> <p>19 1/2"</p>		<p>Photo #: 108</p>	<ul style="list-style-type: none"> • Move toilet • Replace toilet • Move partition •
<p>3.31 Is clearance provided around the water closet measuring at least 60 inches from the side wall and at least 56 inches from the rear wall?*</p>	<p><input type="checkbox"/> Yes <input type="checkbox"/> No</p> <p>Measurement:</p>		<p>• 60" from rear wall</p> <p>• 70" from side wall</p> <p>Photo #: 114</p>	<p>* If constructed before 3/15/12, clearances around water closets in single user toilet rooms can be 48 inches wide by 66 inches long or 48 inches wide by 56 inches long (depending on the approach to the water closet, see 1991 Standards Figure 28) and the lavatory may overlap</p>

			<p>Photo #:</p>	<p>that clearance if the door to the room does not swing into the required clearances at fixtures (such as lavatories, water closet and urinals) and the edge of the lavatory is at least 18 inches from the centerline of the water closet</p> <ul style="list-style-type: none"> Alter room/compartment for clearance
<p>3.32 Is the height of the water closet no less than 17 inches and no greater than 19 inches above the floor measured to the top of the seat?</p>	<p><input checked="" type="checkbox"/> Yes <input type="checkbox"/> No</p> <p>Measurement:</p>		<p>• Height 17"</p> <p>Photo #: 105</p>	<ul style="list-style-type: none"> Adjust toilet height Replace toilet
<p>3.33 Is there a grab bar at least 42 inches long on the side wall?</p> <p>Is it located no more than 12 inches from the rear wall?</p> <p>Does it extend at least 54 inches from the rear wall?</p> <p>Is it mounted no less than 33</p>	<p><input checked="" type="checkbox"/> Yes <input type="checkbox"/> No</p> <p>Measurement:</p> <p><input checked="" type="checkbox"/> Yes <input type="checkbox"/> No</p> <p>Measurement:</p> <p><input type="checkbox"/> Yes <input checked="" type="checkbox"/> No</p> <p>Measurement:</p> <p><input checked="" type="checkbox"/> Yes <input type="checkbox"/> No</p>		<p>• 42 " grab bar</p> <p>• 10 ½" from rear wall</p> <p>• Center line 34" above finished floor</p>	<ul style="list-style-type: none"> Install grab bar Relocate grab bar Relocate objects

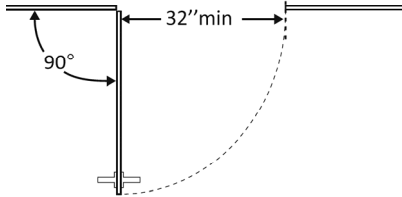
<p>inches and no greater than 36 inches above the floor to the top of the gripping surface?</p> <p>Is there at least 12 inches clearance between the grab bar and protruding objects above?*</p> <p>Is there at least 1½ inches clearance between the grab bar and projecting objects below?*</p> <p>Is the space between the wall and the grab bar 1 ½ inches?</p>	<p>Measurement:</p> <p><input type="checkbox"/> Yes <input type="checkbox"/> No</p> <p>Measurement:</p> <p><input type="checkbox"/> Yes <input type="checkbox"/> No</p> <p>Measurement:</p> <p><input type="checkbox"/> Yes <input type="checkbox"/> No</p> <p>Measurement:</p>		<p>• Mounted 34"</p> <p>Photo #:</p>	<p>* If constructed before 3/15/2012 grab bars do not need to be relocated; there are no space requirements above and below grab bars in the 1991 Standards</p>
<p>3.34 Is there a grab bar at least 36 inches long on the rear wall?</p> <p>Does it extend at least 12 inches from the centerline of the water closet on one side (side wall)?</p> <p>Does it extend at least 24 inches on the other (open) side?</p> <p>Is it mounted no less than 33 inches and no greater than 36 inches above the floor to the top of the gripping surface?</p>	<p><input checked="" type="checkbox"/> Yes <input type="checkbox"/> No</p> <p>Measurement:</p> <p><input checked="" type="checkbox"/> Yes <input type="checkbox"/> No</p> <p>Measurement:</p> <p><input checked="" type="checkbox"/> Yes <input type="checkbox"/> No</p> <p>Measurement:</p> <p><input type="checkbox"/> Yes <input type="checkbox"/> No</p> <p>Measurement:</p>		<p>• Grab Bar 36"</p> <p>Photo #:</p> <p>• Mounted 33 ½"</p> <p>Photo #:</p>	<ul style="list-style-type: none"> • Install grab bar • Relocate grab bar • Relocate objects •

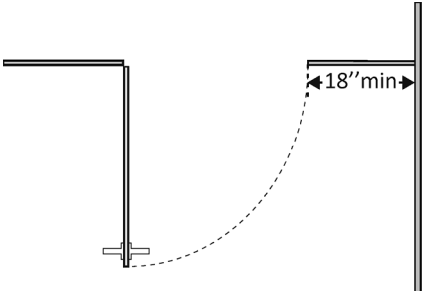
<p>Are there at least 12 inches clearance between the grab bar and protruding objects above?*</p> <p>Are there at least 1½ inches clearance between the grab bar and projecting objects below?*</p> <p>Is the space between the wall and the grab bar 1 ½ inches?</p>	<p><input type="checkbox"/> Yes <input type="checkbox"/> No Measurement:</p> <p><input type="checkbox"/> Yes <input type="checkbox"/> No Measurement:</p> <p><input type="checkbox"/> Yes <input type="checkbox"/> No Measurement:</p>		<p style="text-align: center;">NA</p> <p>Photo #:</p>	<p>* If constructed before 3/15/2012 grab bars do not need to be relocated; there are no space requirements above and below grab bars in the 1991 Standards</p>
<p>3.35 If the flush control is hand operated, is the operable part located no higher than 48 inches above the floor?</p>	<p><input type="checkbox"/> Yes <input type="checkbox"/> No Measurement:</p>		<p style="text-align: center;">NA AUTOMATIC FLUSH WALL MOUNT</p> <p>Photo #:</p>	<ul style="list-style-type: none"> • Move control • Install sensor with override button no higher than 48 inches •
<p>3.36 If the flush control is hand operated, can it be operated with one hand and without tight grasping, pinching, or twisting of the wrist?</p> <p>Is the force required to activate the flush control no greater than 5 pounds?</p>	<p><input type="checkbox"/> Yes <input type="checkbox"/> No Measurement:</p> <p><input type="checkbox"/> Yes <input type="checkbox"/> No Measurement:</p>		<p style="text-align: center;">NA</p> <p>Photo #:</p>	<ul style="list-style-type: none"> • Change control • Adjust control •

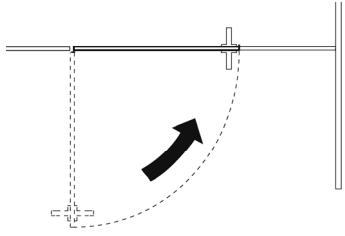
<p>3.37 Is the flush control on the open side of the water closet?</p>	<p><input type="checkbox"/> Yes <input type="checkbox"/> No</p>		<p style="text-align: center;">NA</p> <p>Photo #:</p>	<ul style="list-style-type: none"> • Move control • •
<p>3.38 Is the toilet paper dispenser located no less than 7 inches and no greater than 9 inches from the front of the water closet to the centerline of the dispenser?*</p>	<p><input type="checkbox"/> Yes <input checked="" type="checkbox"/> No</p> <p>Measurement:</p>		<p>Photo #: 109</p>	<p>* If constructed before 3/15/2012 dispenser does not need to be relocated if it is within reach from the water closet seat; the 1991 Standards do not specify distance from the front of the water closet</p> <ul style="list-style-type: none"> • Relocate dispenser • •
<p>3.39 Is the outlet of the dispenser:</p> <p>Located no less than 15 inches and no greater than 48 inches above the floor?</p> <p>Not located behind grab bars?</p>	<p><input type="checkbox"/> Yes <input checked="" type="checkbox"/> No</p> <p>Measurement:</p> <p><input type="checkbox"/> Yes <input checked="" type="checkbox"/> No</p>		<p>Photo #: 110</p> <ul style="list-style-type: none"> • 24" ABOVE FINISHED FLOOR 	<ul style="list-style-type: none"> • Relocate dispenser • •

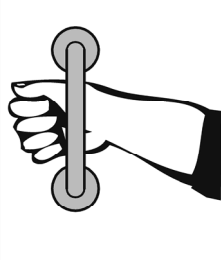
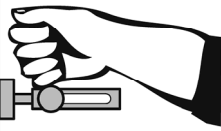
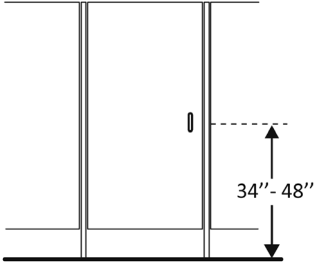
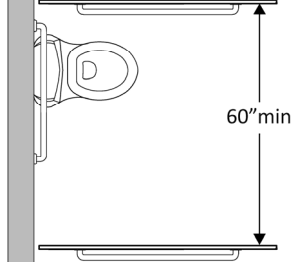
<p>3.40 Does the dispenser allow continuous paper flow?</p>	<p><input checked="" type="checkbox"/> Yes <input type="checkbox"/> No</p>		<p>Photo #:</p>	<ul style="list-style-type: none"> • Adjust dispenser • Replace dispenser •
--	--	---	-----------------	--

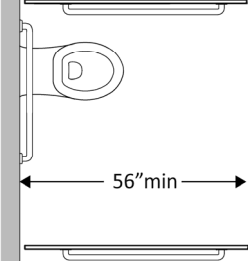
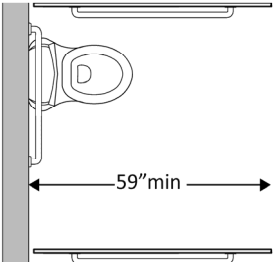
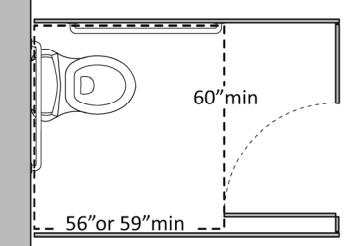
Toilet Compartments (Stalls) (2010 Standards – 604)

<p>3.41 Is the door opening width at least 32 inches clear, between the face of the door and the stop, when the door is open 90 degrees?</p>	<p><input checked="" type="checkbox"/> Yes <input type="checkbox"/> No</p> <p>Measurement:</p>		<p>Photo #:</p>	<ul style="list-style-type: none"> • Widen door width • •
---	--	--	-----------------	--

<p>3.42 If there is a front approach to the pull side of the door, is there at least 18 inches of maneuvering clearance beyond the latch side plus 60 inches clear depth?*</p>	<p><input type="checkbox"/> Yes <input type="checkbox"/> No</p> <p>Measurement:</p>		<p>Photo #:</p>	<p>*See 2010 Standards 604.8.1.2 Doors for maneuvering clearance requirements on the push side of the door and side approaches to the pull side of the door</p> <ul style="list-style-type: none"> • Remove obstructions •
---	---	---	-----------------	--

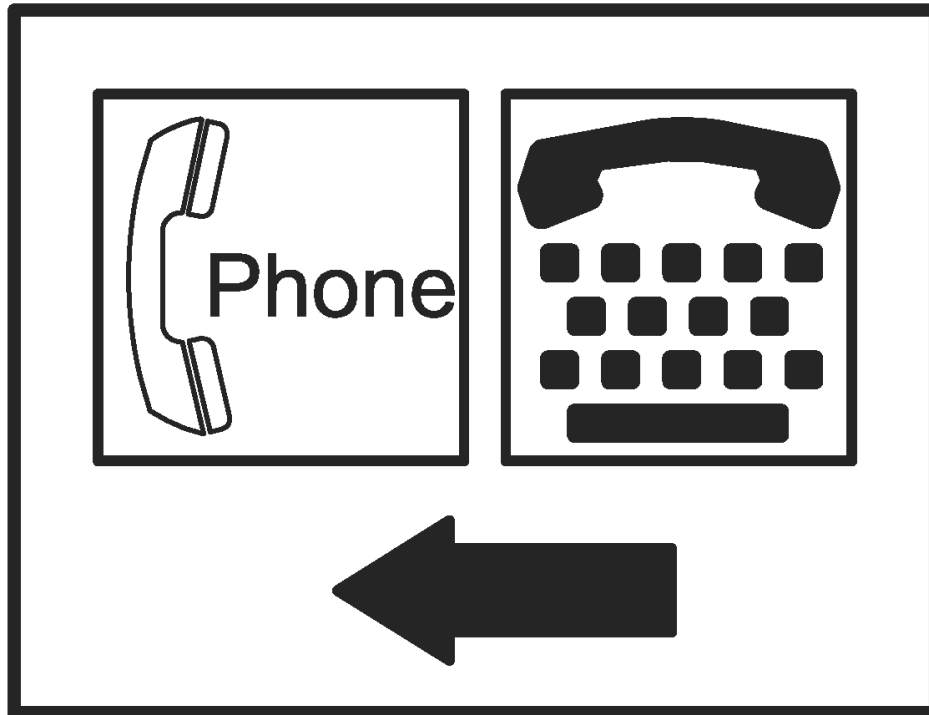
<p>3.43 Is the door self-closing?</p>	<p><input type="checkbox"/> Yes <input type="checkbox"/> No</p>		<p>Photo #:</p>	<ul style="list-style-type: none"> • Add closer • Replace door •
--	---	--	-----------------	---

<p>3.44 Are there door pulls on both sides of the door that are operable with one hand and do not require tight grasping pinching or twisting of the wrist?*</p>	<p><input checked="" type="checkbox"/> Yes <input type="checkbox"/> No</p>		<p>Photo #:</p>	<p>* If constructed before 3/15/2012 door pulls do not need to be added; door pulls are not required in the 1991 Standards</p> <ul style="list-style-type: none"> • Replace hardware • •
<p>3.45 Is the lock operable with one hand and without tight grasping, pinching or twisting of the wrist?</p>	<p><input checked="" type="checkbox"/> Yes <input type="checkbox"/> No</p>		<p>Photo #:</p>	<ul style="list-style-type: none"> • Replace lock • •
<p>3.46 Are the operable parts of the door hardware mounted no less than 34 inches and no greater than 48 inches above the floor?</p>	<p><input checked="" type="checkbox"/> Yes <input type="checkbox"/> No</p> <p>Measurement:</p> <p>41 1/2"</p>		<p>Photo #: 100</p>	<ul style="list-style-type: none"> • Relocate hardware • •
<p>3.47 Is the compartment at least 60 inches wide?</p>	<p><input type="checkbox"/> Yes <input type="checkbox"/> No</p> <p>Measurement:</p>		<p>Photo #:</p>	<ul style="list-style-type: none"> • Widen compartment • •

<p>3.48 If the water closet is wall hung, is the compartment at least 56 inches deep?</p>	<p><input type="checkbox"/> Yes <input type="checkbox"/> No</p> <p>Measurement:</p>		<p>Photo #:</p>	<ul style="list-style-type: none"> • Widen compartment • •
<p>3.49 If the water closet is floor mounted, is the compartment at least 59 inches deep?</p>	<p><input type="checkbox"/> Yes <input type="checkbox"/> No</p> <p>Measurement:</p>		<p>Photo #:</p>	<ul style="list-style-type: none"> • Alter compartment • •
<p>3.50 If the door swings in, is the minimum required compartment area provided beyond the swing of the door (60 inches x 56 inches if water closet is wall hung or 59 inches if water closet is floor mounted)?</p>	<p><input type="checkbox"/> Yes <input type="checkbox"/> No</p> <p>Measurement:</p>		<p>Photo #:</p>	<ul style="list-style-type: none"> • Reverse door swing • Alter compartment •
	<p><input type="checkbox"/> Yes <input type="checkbox"/> No</p>		<p>Photo #:</p>	<ul style="list-style-type: none"> • • •
	<p><input type="checkbox"/> Yes <input type="checkbox"/> No</p>		<p>Photo #:</p>	<ul style="list-style-type: none"> • • •

ADA Checklist for Readily Achievable Barrier Removal

Priority 4 – Additional Access



Project **SDDOT Rest Area Improvements**

FHU Reference Number 13-039-01

TSP Project Number 03120855

Building **TILFORD WEST**

Location **90 W., MRM 41**

Date **09-19-2013 (Inspection)**

Surveyors **Timothy Roach, AIA**

Todd Schultz, PE

Contact Information **TSP – (605) 343-6102**

Amenities such as drinking fountains and public telephones should be accessible to people with disabilities.



Institute for Human Centered Design
www.HumanCenteredDesign.org

November 2011



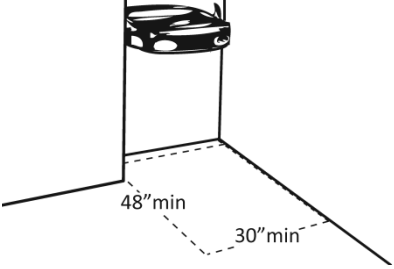
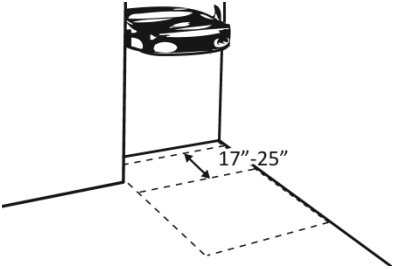
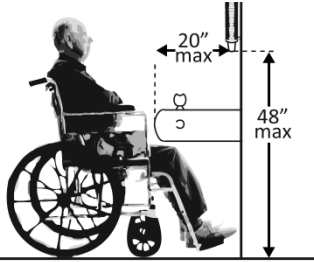
ADA National Network
Questions on the ADA 800-949-4232 voice/tty

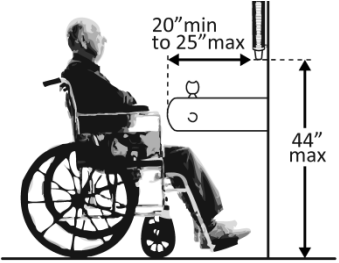

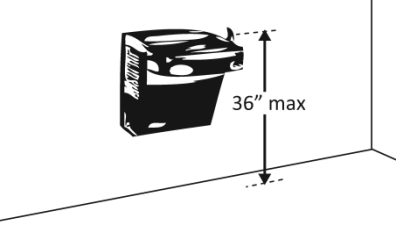
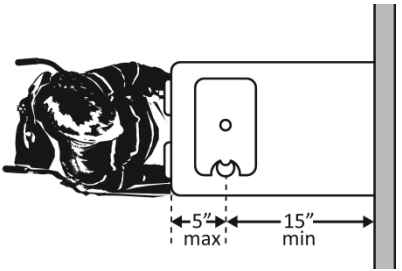
www.ADAchecklist.org

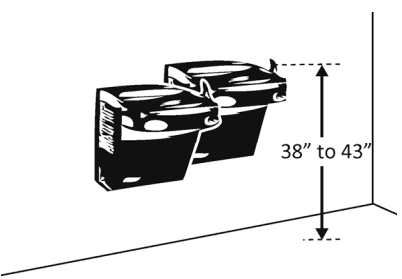
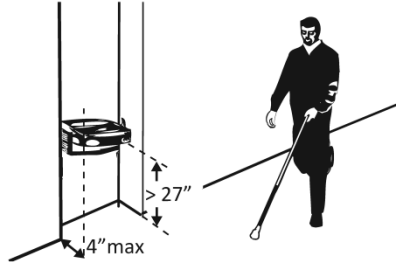
This checklist was produced by the New England ADA Center, a project of the Institute for Human Centered Design and a member of the ADA National Network. This checklist was developed under a grant from the Department of Education, NIDRR grant number H133A060092-09A. However the contents do not necessarily represent the policy of the Department of Education, and you should not assume endorsement by the Federal Government.

Questions or comments on the checklist contact the New England ADA Center at 617-695-0085 voice/tty or ADAinfo@NewEnglandADA.org

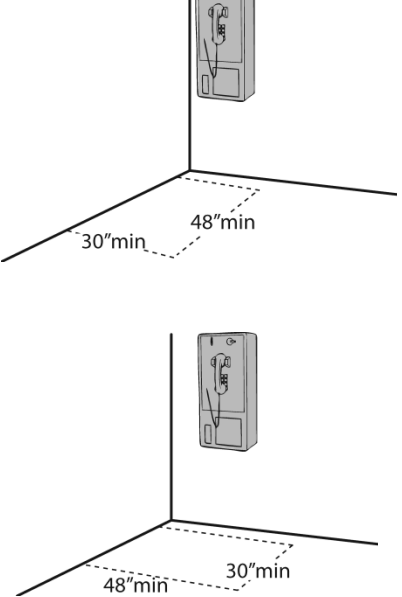
For the full set of checklists, including the checklists for recreation facilities visit www.ADAchecklist.org.

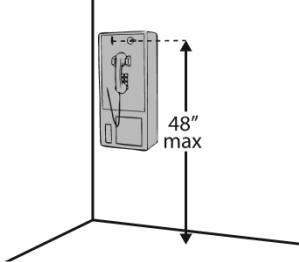
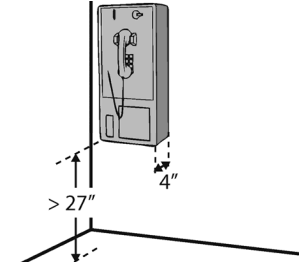


Priority 4 – Additional Access		Comments	Possible Solutions	
Drinking Fountains (2010 Standards – 602)				
<p>4.1 Does at least one drinking fountain have a clear floor space at least 30 inches wide x at least 48 inches long centered in front of it for a forward approach?*</p>	<p><input checked="" type="checkbox"/> Yes <input type="checkbox"/> No</p> <p>Measurement:</p>	 <p>48" min 30" min</p>	<p>• 30" WIDE CLEARANCE</p> <p>Photo #:</p>	<p>*If installed before 3/15/2012, a parallel approach is permitted and the clear floor space is not required to be centered</p> <ul style="list-style-type: none"> • Alter space • Relocate drinking fountain • Install a drinking fountain in another location
<p>4.2 If there is a forward approach, do no less than 17 inches and no greater than 25 inches of the clear floor space extend under the drinking fountain?</p>	<p><input type="checkbox"/> Yes <input type="checkbox"/> No</p> <p>Measurement:</p>	 <p>17"-25"</p>	<p>Photo #:</p> <p style="text-align: center;">NA</p>	<ul style="list-style-type: none"> • Alter space • Replace drinking fountain •
<p>4.3 If the drinking fountain is no deeper than 20 inches, are the operable parts no higher than 48 inches above the floor?</p>	<p><input type="checkbox"/> Yes <input type="checkbox"/> No</p> <p>Measurement:</p>	 <p>20" max 48" max</p>	<p>Photo #:</p>	<ul style="list-style-type: none"> • Adjust drinking fountain • Replace drinking fountain •




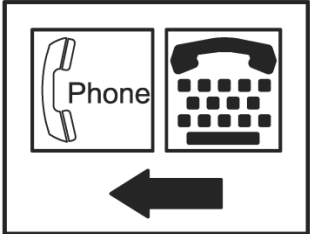
<p>4.4 If the drinking fountain is no less than 20 inches and no greater than 25 inches deep, are the operable parts no higher than 44 inches above the floor?</p>	<p><input type="checkbox"/> Yes <input type="checkbox"/> No</p> <p>Measurement:</p>		<p style="text-align: center; color: red; font-weight: bold;">NA</p> <p>Photo #:</p>	<ul style="list-style-type: none"> • Adjust drinking fountain • Replace drinking fountain •
<p>4.5 Can the control be operated with one hand and without tight grasping, pinching or twisting of the wrist?</p> <p>Is the force required to activate the control no more than 5 pounds?</p>	<p><input type="checkbox"/> Yes <input type="checkbox"/> No</p> <p><input type="checkbox"/> Yes <input type="checkbox"/> No</p> <p>Measurement:</p>		<p>Photo #: 92</p>	<ul style="list-style-type: none"> • Change control • Adjust control •
<p>4.6 Is the spout outlet no higher than 36 inches above the floor?</p>	<p><input checked="" type="checkbox"/> Yes <input type="checkbox"/> No</p> <p>Measurement:</p>		<p>Photo #: 96</p>	<ul style="list-style-type: none"> • Adjust drinking fountain • Replace drinking fountain •
<p>4.7 Is the spout:</p> <p>At least 15 inches from the rear of the drinking fountain?</p> <p>No more than 5 inches from the front of the drinking fountain?</p>	<p><input checked="" type="checkbox"/> Yes <input type="checkbox"/> No</p> <p>Measurement:</p> <p><input checked="" type="checkbox"/> Yes <input type="checkbox"/> No</p> <p>Measurement:</p>		<p>Photo #: 95</p>	<ul style="list-style-type: none"> • Adjust spout • Replace drinking fountain •

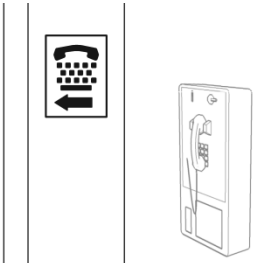

<p>4.8 If there is more than one drinking fountain, is there at least one for standing persons?</p> <p>Is the spout outlet no lower than 38 inches and no higher than 43 inches above the floor?</p>	<p><input type="checkbox"/> Yes <input type="checkbox"/> No</p> <p><input type="checkbox"/> Yes <input type="checkbox"/> No</p> <p>Measurement:</p>		<p>Photo #:</p>	<ul style="list-style-type: none"> • Adjust drinking fountain • Install new drinking fountain for standing height •
<p>4.9 If the leading (bottom) edge of the fountain is higher than 27 inches above the floor, does the front of the fountain protrude no more than 4 inches into the circulation path?</p>	<p><input type="checkbox"/> Yes <input type="checkbox"/> No</p> <p>Measurement:</p>		<p>Photo #:</p> <p style="text-align: center; color: red; font-weight: bold;">NA</p>	<ul style="list-style-type: none"> • Adjust drinking fountain • Replace drinking fountain • Add tactile warning such as permanent planter or partial walls

Public Telephones (2010 Standards – 704) TTY's are devices that employ interactive text-based communication through the transmission of coded signals across the telephone network. They are mainly used by people who are deaf and/or cannot speak.

<p>4.10 Does at least one telephone have a clear floor space at least 30 inches wide x at least 48 inches long for a parallel or forward approach?</p>	<p><input checked="" type="checkbox"/> Yes <input type="checkbox"/> No</p>		<p>Photo #: 98</p>	<ul style="list-style-type: none"> • Move telephone • Install new telephone for clear floor space •
---	--	---	---------------------------	--

<p>4.11 Is the highest operable part of the telephone no higher than 48 inches above the floor?</p>	<p><input checked="" type="checkbox"/> Yes <input type="checkbox"/> No</p> <p>Measurement:</p>		<p>Photo #: 99</p>	<ul style="list-style-type: none"> • Adjust telephone • •
<p>4.12 If the leading (bottom) edge of the telephone is higher than 27 inches above the floor, does the front of the telephone protrude no more than 4 inches into the circulation path?</p>	<p><input type="checkbox"/> Yes <input checked="" type="checkbox"/> No</p> <p>Measurement:</p>		<p>Photo #:</p>	<ul style="list-style-type: none"> • Adjust telephone • •
<p>4.13 Does at least one telephone have a volume control?</p>	<p><input type="checkbox"/> Yes <input checked="" type="checkbox"/> No</p>		<p>Photo #:</p>	<ul style="list-style-type: none"> • Install volume control • Replace telephone with one that has volume control •
<p>4.14 Is the volume control identified by a pictogram of a telephone handset with radiating sound waves?</p>	<p><input type="checkbox"/> Yes <input checked="" type="checkbox"/> No</p>		<p>Photo #:</p>	<ul style="list-style-type: none"> • Add pictogram • •

<p>4.15 Does at least one telephone have a TTY?</p>	<p><input type="checkbox"/> Yes <input checked="" type="checkbox"/> No</p>		<p>Photo #:</p>	<ul style="list-style-type: none"> • Install TTY • •
<p>4.16 Is the touch surface of the TTY keypad at least 34 inches above the floor?</p>	<p><input type="checkbox"/> Yes <input type="checkbox"/> No Measurement:</p>		<p>Photo #:</p> <p style="text-align: center;">NA</p>	<ul style="list-style-type: none"> • If a seat is provided, TTY is not required to be 34 inches minimum above the floor • Adjust height of TTY •
<p>4.17 Is the TTY identified by the International Symbol of TTY?</p>	<p><input type="checkbox"/> Yes <input type="checkbox"/> No</p>		<p>Photo #:</p> <p style="text-align: center;">NA</p>	<ul style="list-style-type: none"> • Add symbol • •
<p>4.18 Do signs that provide direction to public telephones also provide direction to the TTY?</p>	<p><input type="checkbox"/> Yes <input type="checkbox"/> No</p>		<p>Photo #:</p> <p style="text-align: center;">NA</p>	<ul style="list-style-type: none"> • Add signs • •

<p>4.19 Do telephones that do not have a TTY provide direction to the TTY?</p>	<input type="checkbox"/> Yes <input type="checkbox"/> No		<p style="text-align: center;">NA</p> <p>Photo #:</p>	<ul style="list-style-type: none"> • Add signs • •
<p>Fire Alarm Systems (2010 Standards – 702)</p>				
<p>4.20 If there are fire alarm systems, do they have both flashing lights and audible signals?</p>	<input type="checkbox"/> Yes <input type="checkbox"/> No		<p style="text-align: center;">NA</p> <p>Photo #:</p>	<ul style="list-style-type: none"> • Install audible and visual alarms • •
	<input type="checkbox"/> Yes <input type="checkbox"/> No		<p>Photo #:</p>	<ul style="list-style-type: none"> • • •
	<input type="checkbox"/> Yes <input type="checkbox"/> No		<p>Photo #:</p>	<ul style="list-style-type: none"> • • •
	<input type="checkbox"/> Yes <input type="checkbox"/> No		<p>Photo #:</p>	<ul style="list-style-type: none"> • • •

TILFORD WEST PRIORITY 1



Photo #1



Photo #2



Photo #3



Photo #4

TILFORD WEST PRIORITY 1

Photo #5



Photo #6



Photo #7



Photo #8



TILFORD WEST PRIORITY 1



Photo #9



Photo #11



Photo #12

Photo #13



TILFORD WEST PRIORITY 1

Photo #14



Photo #15



Photo #17



Photo #19

TILFORD WEST PRIORITY 1



Photo #20

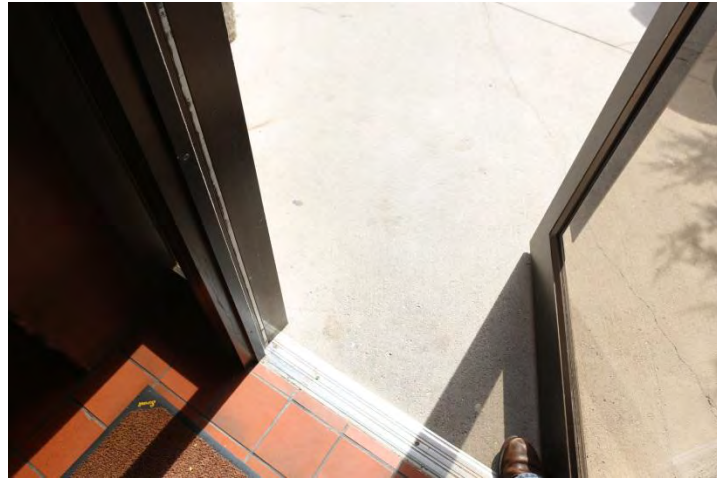


Photo #21

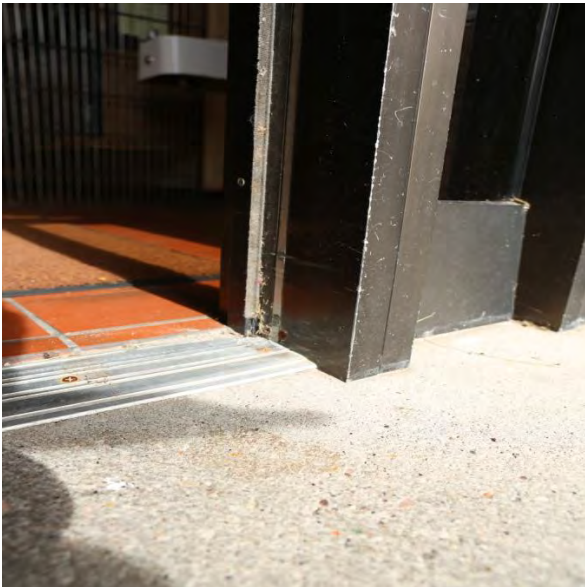


Photo #23



Photo #24

TILFORD WEST PRIORITY 1



Photo #25



Photo #26



Photo #27



Photo #28

TILFORD WEST PRIORITY 1



Photo #29



Photo #30



Photo #31

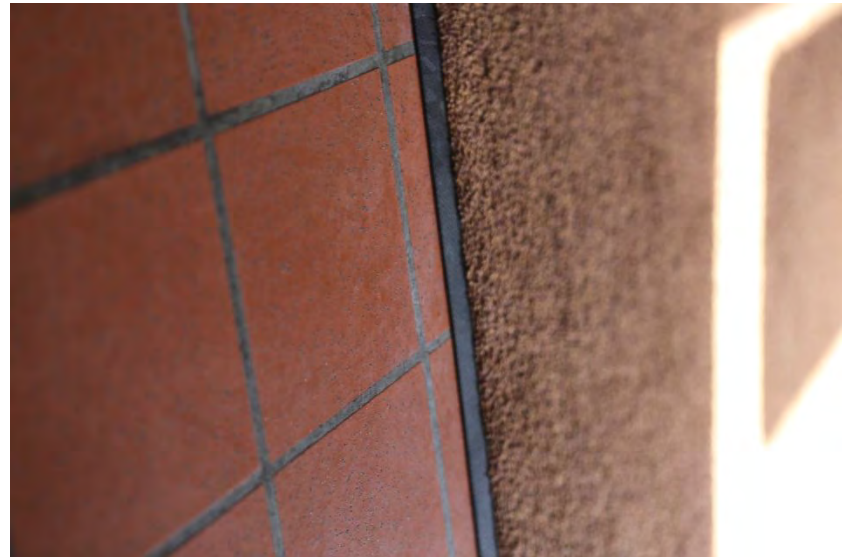


Photo #32

TILFORD WEST PRIORITY 1



Photo #C0123



Photo #C0125

TILFORD WEST PRIORITY 2

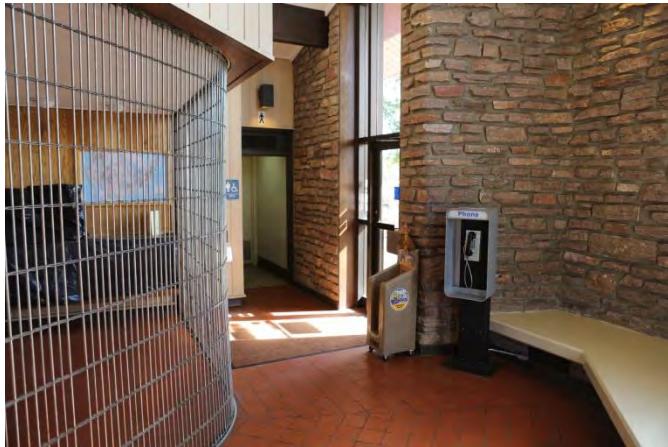


Photo #33

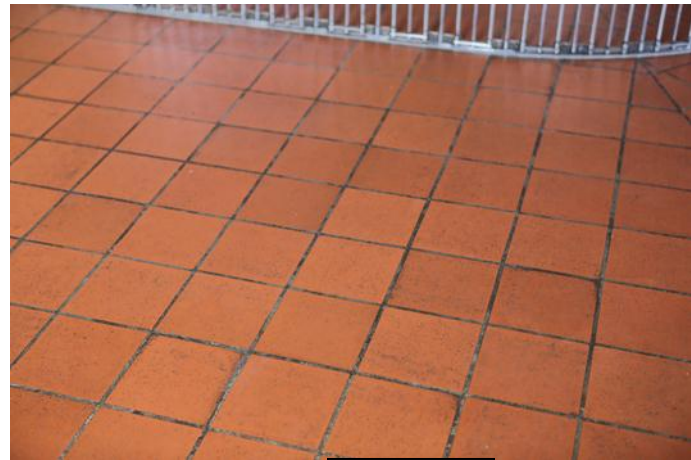


Photo #35



Photo #36

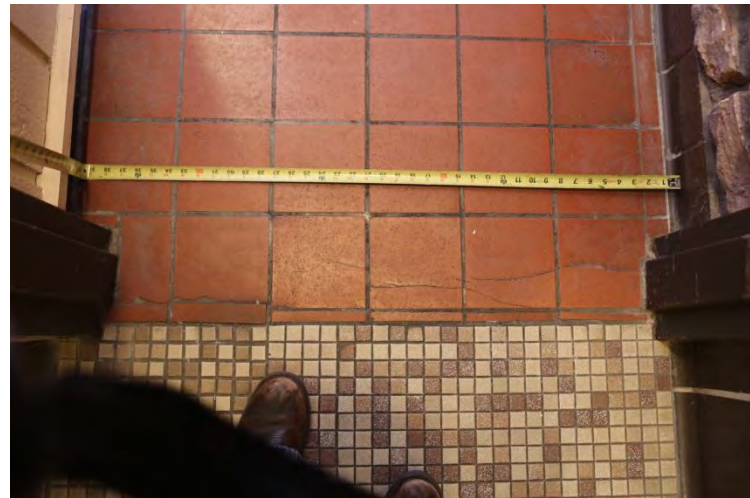


Photo #39

TILFORD WEST PRIORITY 2



Photo #40

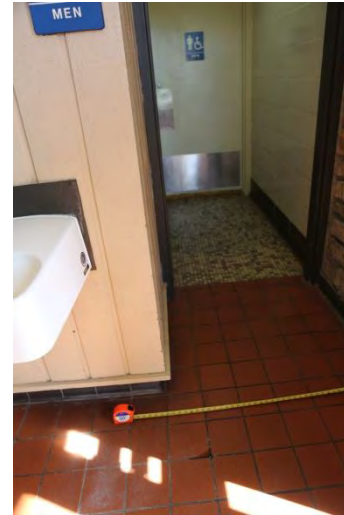


Photo #41



Photo #42

Photo #43



TILFORD WEST PRIORITY 2

Photo #44



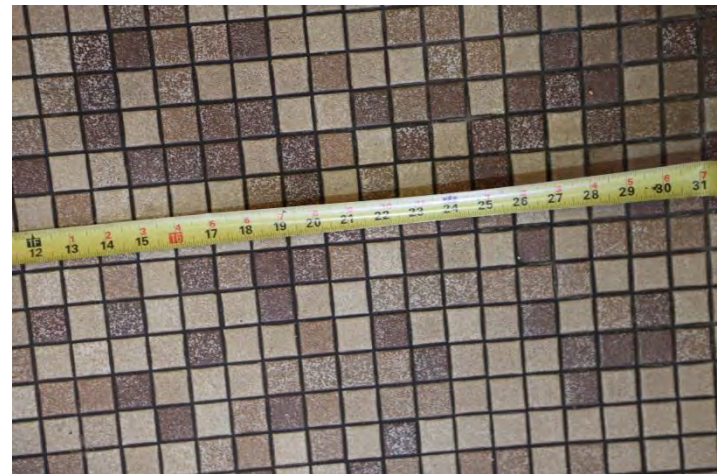
Photo #45



Photo #46



Photo #47



TILFORD WEST PRIORITY 2



Photo #48

Photo #49



Photo #50



Photo #51

TILFORD WEST PRIORITY 2

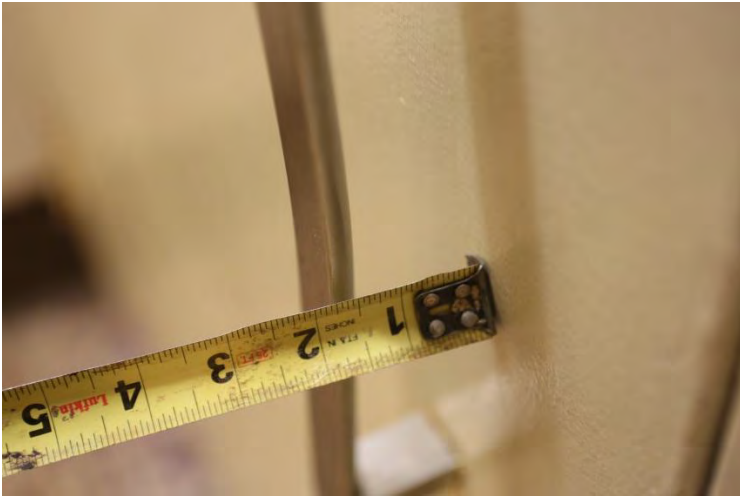


Photo #52



Photo #53



Photo #54



Photo #55

TILFORD WEST PRIORITY 2



Photo #56



Photo #57

TILFORD WEST PRIORITY 3 - MEN'S



Photo #58



Photo #59



Photo #60



Photo #61

TILFORD WEST PRIORITY 3 - MEN'S



Photo #62



Photo #63



Photo #64



Photo #65

TILFORD WEST PRIORITY 3 - MEN'S



Photo #100



Photo #101



Photo #102



Photo #103

TILFORD WEST PRIORITY 3 - MEN'S

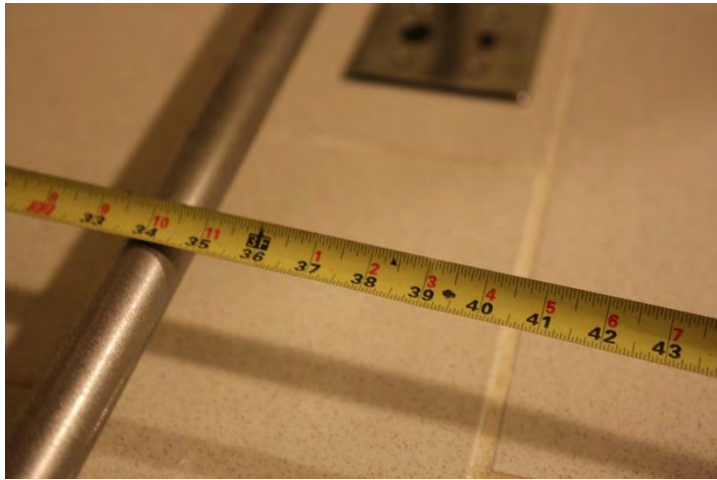


Photo #104



Photo #105



Photo #107



Photo #108

TILFORD WEST PRIORITY 3 - MEN'S



Photo #109

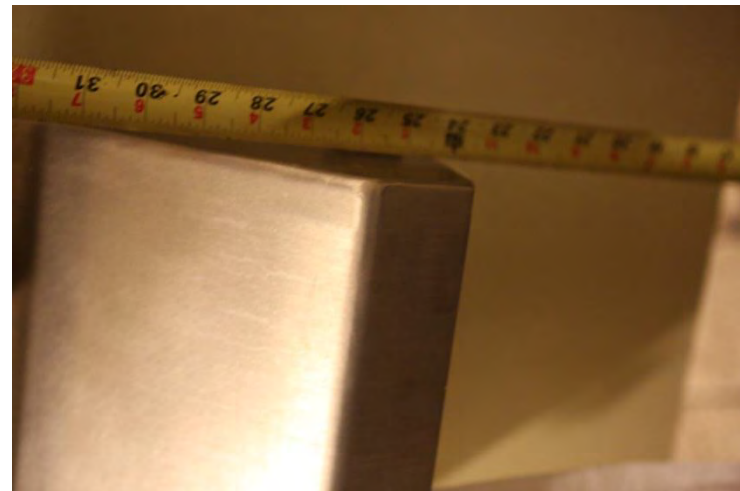


Photo #110



Photo #111



Photo #112

TILFORD WEST PRIORITY 3 - MEN'S



Photo #113

Photo #114



Photo #115

TILFORD WEST PRIORITY 3 - WOMEN'S



Photo #66



Photo #67



Photo #68



Photo #69

TILFORD WEST PRIORITY 3 - WOMEN'S



Photo #70



Photo #71



Photo #72

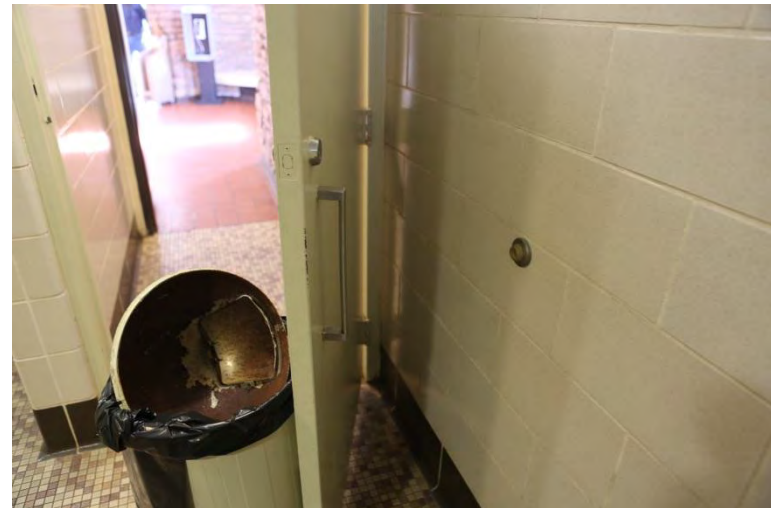


Photo #73

TILFORD WEST PRIORITY 3 - WOMEN'S



Photo #74



Photo #75



Photo #76



Photo #77

TILFORD WEST PRIORITY 3 - WOMEN'S



Photo #78



Photo #79



Photo #80



Photo #81

TILFORD WEST PRIORITY 3 - WOMEN'S



Photo #82



Photo #83

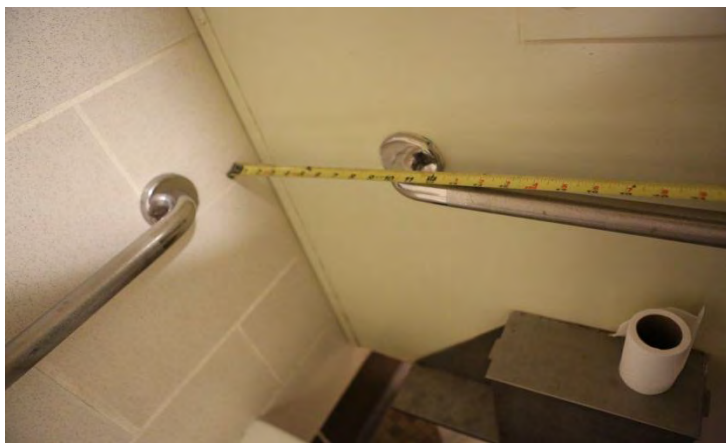


Photo #84

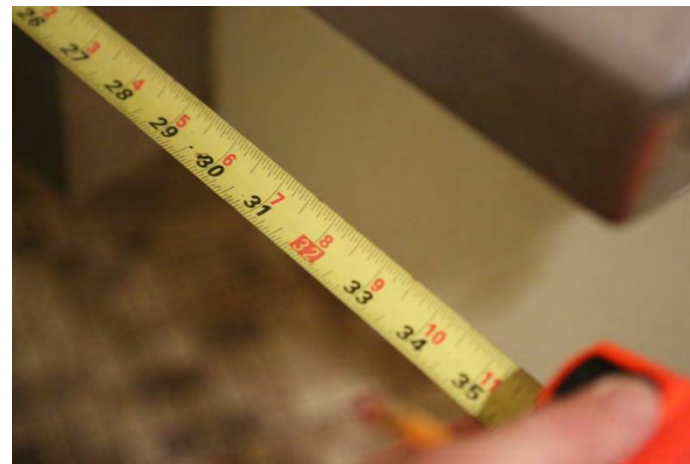


Photo #85

TILFORD WEST PRIORITY 3 - WOMEN'S

Photo #86



Photo #88



Photo #89



Photo #90

TILFORD WEST PRIORITY 3 - WOMEN'S



Photo #91

TILFORD WEST PRIORITY 4



Photo #92



Photo #94

TILFORD WEST PRIORITY 4



Photo #95



Photo #96



Photo #98



Photo #99



The Interstate Rest Areas Study: Along the I-29 and I-90 Corridors

APPENDIX C AUDITMATE SUMMARY

List of recommended additions/modifications to the AuditMate data base

(note, revisions shown in **BOLD**)

Detailed Component List for One Facility
TILF_RAW Tilford Rest Area West

\$41,564

Class	Component	Comment	Quantity	Unit Cost	Lifespan	Age	Installed	Renewal Cost (RC)	Deferred Cost (DC)
Site Structures									
	Utility Storage Shed	10x12 and 10x20 sheds. Sheds used for general equipment and travel storage. Needs to be replaced.	2	\$10,000.00	15	15?		\$20,000	
	Reinforced Concrete Picnic Shelter	30x30 good condition. At this age facility will need routine structural inspection	1	\$30,000.00	75	37	1966	\$30,000	
	Precast Concrete Picnic Shelter	Structures need routine structural inspection of welded plate connections and minor repairs to plates, concrete, and paint	4	\$5,000.00	75	37	1966	\$20,000	
	Reinforced Concrete Picnic Tables	Tables appear to be in good condition	12	\$4,000.00	75	37	1966	\$48,000	
	Information Display (outdoor)	Appears to be in good condition - but dirty			20				
Exterior Closure									
	Insulated Stone Wall System	No evident of heavy wear, cracking, or spalling			75	40	1973		
	CMU Exterior Wall (uninsulated)	No evident of heavy wear, cracking, or spalling			75	40	1966		
	Masonry Wall Mortar & CMU Wall	Good condition. Tuck-pointing seems to have been completed over the years. Recommend mason inspection, tuck-pointing, and caulking			65	47	1966		
	Paint or Stain Exterior (CMU)	Existing paint seems only a few years old and not original (as shown in AuditMate). Touch up recommended at base.			10	5?	1989		
	Paint Exterior (Soffits, Trim and Service Door)	Existing paint seems only a few years old and not original.			10	5?	1989		
	Steel Double Door (uninsulated)	Good working order. Needs painting.			30	24			
	Storefront Single Door (alum. & Glass)	Life span 10 years in heavy use (not 50) - fair condition. Needs threshold and new pull hardware (ADA). Should replace with insulating glass. Door doesn't appear to be original.			15	10?	1973	\$2,000	
	Alum. Frame & Glazing - Storefront Uninsul.	In fair condition - Inspect and replace sealants periodically. Should replace with insulating glass & frame system.			45	40	1973		
	Alum. Frame & Glazing - Windows Uninsul.	Fair condition but old			45	40	1973		
	Glass Block Windows	8 @ 16" x 16" - Fair condition but old	8		60	47	1966		
Roofing and Drainage									
	Galvanized Metal Roof, Standing Seam, Factory Finish	Good condition, some sagging apparent at long spans. Recommend structural engineer review while reviewing picnic shelters. New system replaced existing built up roof system.		\$25.00/sf					

List of recommended additions/modifications to the AuditMate data base

(note, revisions shown in **BOLD**)

Detailed Component List for One Facility

\$41,564

TILF_RAW Tilford Rest Area West

Class	Component	Comment	Quantity	Unit Cost	Lifespan	Age	Installed	Renewal Cost (RC)	Deferred Cost (DC)
	Downspouts, Galvanized Steel, Factory Finish			\$10/sf					
	Gutters, Galvanized Steel, Hung	Replaced existing internal roof drain system. New system appears to be in good condition.		\$10/sf					
Interior Construction									
	Toilet Partition, Metal, Baked Enamel Finish	Seem original but in fair shape. Could use refinishing							
	Urinal Partition, Metal, Baked Enamel Finish	Seem original but in fair shape. Could use refinishing							
	Ceramic Tile Wall-Glazed CMU (restrooms)	Fair condition, requires a thorough cleaning of surface and grout. Interior wall appears to be a 4" or 6" Glazed CMU wall. Could conceivably be tiled over.							
	Painting, Interior, Average Grade	Recalculate SF in AuditMate to include Lobby walls and ceilings, restroom ceilings, maintenance areas.							
	Ceramic Tile Floor (restrooms 1/2"x1/2 ")	Recommend deep cleaning & minor repairs at a minimum. Replacement preferred.							
	Epoxy Paint Floor Quarry Tile Floor (Lobby 6"x6")	Abrasive grain is worn off - floors will get slippery. Recommend replacement in high traffic areas. At a minimum, clean grout and some replacement tile needed (10 sf).			20				
	Toilet Stall Door, Metal, Baked Enamel Finish	Seem original but in fair shape. Could use refinishing							
	Interior Doors and Hardware		2		20				
	SS Security Gate Assembly	Needs replacement ASAP			35	40	1973		
	Information Desk & Map Counter	Needs replacement ASAP			20	40	1973		
Plumbing									
	Sewage Ejection Pump, Duplex, 2" Discharge, Over	There are no reported issues.							
	Tank, Holding Tank, 5000 gallons	There are no reported issues. Suggest periodically testing for bacterial growth in the tanks.							
	Water Softening System, Residential	There are no reported issues. Assuring that the water softener is regenerated properly will help to extend the life of the resin. Resin can gel if not periodically and continuously regenerated.							
	Well Pressure tank, Medium	Tank appears to be in good condition							
	Well Pump	Delete line item - well is located at Tilford East Side	1 each	\$640.00	25	11	2002	\$640	\$0
	Water Fountain, Porcelain	Needs minor valve repair							

List of recommended additions/modifications to the AuditMate data base

(note, revisions shown in **BOLD**)

Detailed Component List for One Facility

\$41,564

TILF_RAW Tilford Rest Area West

Class	Component	Comment	Quantity	Unit Cost	Lifespan	Age	Installed	Renewal Cost (RC)	Deferred Cost (DC)
	Water Heater, Residential, Electric 20-50 gallons	Appears to be in good condition. Occasionally blowing the bottom out to remove residue and scale may add another 2 years to its life.							
	Cabinet Countertop, Corian, w/Integral sink								
	Faucets (Lav)	Maintain water quality, and regular maintenance and cleaning will help extend the faucets life							
	Faucets (Lav)	Maintain water quality, and regular maintenance and cleaning will help extend the faucets life							
	Urinals, Porcelain, Wall-Hung	Appear to be in good condition for their age. Replacing units with low water consumption units will extend the life of the lagoon and pumps.							
	Water Closet, Porcelain, Wall-Hung	Replacing units with low water consumption units will extend the life of the lagoon and pumps							
	Waste and Vent Piping	Appears to be in good condition, no apparent leaks			50	40	1973		
	Water Piping	Appears to be in good condition			65	40	1973		
	Piping Insulation	Is in poor condition and should be replaced within the next year. Sweating pipes were observed where insulation was damaged, which in turns damages the remaining insulation. Dripping is also a nuisance in the mechanical room and some water damage occurs to other equipment			30	40	1973		
	Valves	Valves are starting to exhibit some corrosion.			45	40	1973		
	Pipe Hangers and Supports	Appear to be in good condition. Should last another 25 years if humidity is controlled by proper ventilation.			65	40	1973		
Mechanical									
	Furnace - Propane	Furnace is old and needs to be replaced in the near future.			40	40	1973		
	AC Split System Outdoor Condensing, 05 Ton	Unit should be replaced in the near future. The unit has considerable hail damage to the fins, which affects its performance.							

List of recommended additions/modifications to the AuditMate data base

(note, revisions shown in **BOLD**)

Detailed Component List for One Facility
TILF_RAW Tilford Rest Area West

\$41,564

Class	Component	Comment	Quantity	Unit Cost	Lifespan	Age	Installed	Renewal Cost (RC)	Deferred Cost (DC)
	Air Handling Unit, Split System AC/Gas heat, 05 Ton	Electric unit heater appears to be in adequate condition. However, the unit is 40 years old and should be replaced in the near future. It is difficult to determine the condition of electric hearing elements, and this is the only source of heat in the mechanical room where water piping exists, and may freeze if the heater fails.							
	In-Line Exhaust fan	Unit is in good condition for its age.							
	Unit Heater, Electric, Ceiling or Wall Mounted								
	Hydronic Circulating Pump, Base-Mounted, 005 HP	Is in good condition. Should last another 5 years			25	20	2000	\$2,440	
	Humidifier, Electric, Portable, Small								
	Ductwork and Grilles	Units are in adequate condition and will last another 10 years. No adjustments required to AuditMate.			50	40	1973		
	Temperature Controls	Thermostat is in working condition. Consider replacing with a programmable thermostat, similar to the one used in the East Bound rest stop, to save some energy.			60	40	1973		
Electrical									
	Well Monitoring System	Understand in good condition							
	Phone Unit	Floor Mount, replace - Non ADA compliant							
Utilities									
	A/G Propane Gas, Steel Tank 0-100	Understand in good condition							
Sanitary Sewer System									
	Lagoons (3, note 1 supports Tilford east)	The lagoons are scheduled to be overhauled by the SDDOT in a separate project	3 each			40	1972		
	Lift Station Pumps	Pump replacement will be needed periodically. No reported problems	2	\$2,500.00	10			\$5,000	
	Sewage Piping System	No reported problems (force main system and 4" diam. Pipe)			50	40	1973	\$25,000	
Water System (well)									
	Water Pipe System	3" water line - no reported problems.			50	40	1973	\$10,000	
Infrastructure									
	Parking Area, Non Reinforced Concrete 9.5"	Continue periodic joint repair and sealing. May need to replace 2 or 3 panels in the next 5 years.							

List of recommended additions/modifications to the AuditMate data base

(note, revisions shown in **BOLD**)

Detailed Component List for One Facility

\$41,564

TILF_RAW Tilford Rest Area West

Class	Component	Comment	Quantity	Unit Cost	Lifespan	Age	Installed	Renewal Cost (RC)	Deferred Cost (DC)
	Roadway, Asphalt	Asphalt Pavement behind main building, used for handicapped parking, needs to have cracks repaired and the surface chip or slurry sealed. The shoulders along the concrete pavement should have a seal coat applied in the near future.							
	Sidewalk, Concrete	Walks in good shape for the most part. Approximately 10% of walk need replacement in the next 5 - 10 years.							
	Landscaping	Landscaping for the site appears to be in good shape (this site visit occurred prior to the snowstorm of October 4-5, 2013). Grass is well kept and trees appear to be healthy. The sprinkler system is in good working order with only yearly maintenance required. Refreshing of landscaping should be considered at some point.			25	40	1973		
	Wayfinding Signage	Existing signs appear to be in good shape, but could use modernization			50	40	1973		
	Site Lighting - Parking	Replaced a "few years ago".							
	Site Lighting - Pedestrian	Replaced a "few years ago".							



Appendix C. Parking Analysis



The Interstate Rest Areas Study: Along the I-29 and I-90 Corridors

March 14, 2014

REVISED July 19, 2014

MEMORANDUM

TO: Brad Remmich
SDDOT Transportation Planner

FROM: Jeremy Hahn, PE, PTOE
Lyle DeVries, PE, PTOE

SUBJECT: SDDOT Interstate Rest Area Study
Technical Memorandum #3 – Parking Conditions Summary
FHU Reference No. 113039-01

In support of the Interstate Rest Areas Study, included is an analysis of parking conditions at each rest area. The purpose of the analysis is to quantify existing passenger vehicle and truck parking conditions, project parking conditions to a future long term horizon, and determine if parking capacity would need to be expanded to meet the future parking needs. Future parking conditions can also be used to project long term overall use levels at each rest area facility. The following sections of the memorandum detail the existing conditions including the parking inventory, the future parking conditions methodology and the parking expansion potential needed to meet anticipated demand.

EXISTING CONDITIONS

The seven rest areas studied in this report are located throughout South Dakota on both Interstate 29 and Interstate 90. A vicinity map showing the location of the seven rest areas is shown on the following graphic:



A brief description of the access and parking conditions at each site are summarized in the following bullets, and detailed descriptions of each site are contained in the Facility Assessment Reports (previously provided):

- **Hidewood Northbound** - The rest area is accessed directly from Interstate 29 (I-29), with passenger vehicle and truck parking areas separated just upstream of the I-29 gore point. The truck parking area provides eight angled head-in parking spaces, which allows trucks to enter and exit without having to reverse or make complex turning movements. The passenger vehicle parking area provides 24 angle parking spaces with direct access to the rest area facilities. The rest area also provides a parallel parking lane throughout the entire length of the passenger vehicle parking lot for RV / camper / trailer parking.
- **Hidewood Southbound** - The rest area is accessed directly from Interstate 29, with passenger vehicle and truck parking areas separated just upstream of the I-29 gore point. The truck parking area provides seven angled head-in parking spaces and is located approximately 450 feet north of the rest area facilities. The passenger vehicle parking area provides 26 angle parking spaces, and a parallel parking lane throughout the entire length of the passenger vehicle parking lot for RV / camper / trailer parking.
- **Homestead** - Access to the rest area is provided off South Dakota Highway 50 (SD-50), serving both directions of I-29 traffic at Exit 26. The access road loops around the rest area, with a combined passenger vehicle and truck parking area located on the eastern side of the facility. The rest area provides a total of 33 passenger vehicle parking spaces and 27 truck parking spaces, which could also be used by RV / camper / trailers. The truck parking area is angled head-in parking, allowing for efficient entry and exiting of large vehicles.
- **Valley Springs Westbound** - The rest area, which is shared with the Port of Entry (POE), serves passenger vehicle and RV / campers and trailer traffic with direct access to Interstate 90 (I-90). The parking area provides 37 angled parking spaces with direct access to the rest area facilities. In addition, a parallel parking lane is provided on the south side of the lot for larger passenger vehicles (RV / camper / trailer).
- **Valley Springs POE** - Access to the POE is provided directly from I-90 and shared with the adjacent rest area, and truck traffic is separated from passenger vehicle traffic just west of the I-90 gore point. In South Dakota, the POE ensures that motor carriers paperwork, permits and necessary shipping documents are in order. In addition, the POE provides scales to make certain that trucks and trailers meet current South Dakota weight limits. The POE provides seven truck parking spaces, used mainly for short term parking needs or for inspection purposes. In addition, the facility provides four parking spaces for passenger vehicles which are dedicated to South Dakota Highway Patrol personnel.
- **Tilford Eastbound & Westbound** - Each rest area is accessed directly from I-90 and provides similar site layouts. Both parking areas provide both passenger vehicle and truck parking, with direct access from the parking areas to the facilities and visitor center. Each of the two rest areas provide a total of 21 angled passenger vehicle parking spaces and nine parallel truck parking spaces which are also used by larger passenger vehicles (RV / camper / trailer).

Parking Counts

Parking counts at each rest area were conducted during the week of September 16th through the 20th 2013. Video cameras were utilized to capture parking conditions for a 24-hour block of time in both the passenger and truck parking areas. Multiple cameras were positioned in each parking area to ensure all individual parking spaces could be viewed during the 24-hour block of time. The video files were viewed and parking data was collected every five minutes, separated by passenger vehicle and truck parking activity. In addition, locations of illegal parking, for instance trucks parked in passenger vehicle spaces, were quantified at each location. For purposes of this report, trucks are defined as semi-truck and trailer, while passenger vehicles represent all other vehicle types.

Parking Analysis

After compiling the parking data at each rest area, several factors were analyzed to quantify how the facilities operate during the study period. The number of vehicles that parked at each facility during the 24-hour period, summarized in **Table 1**, outlines the overall usage of each rest area. Of note, the estimates are not adjusted for seasonal use.

Table 1. Parked Vehicle Summary

Facility	Total Parked Passenger Vehicles	Total Parked Trucks
Hidewood Northbound	199	83
Hidewood Southbound	170	93
Homestead	104	54
Valley Springs Westbound*	308	
Valley Springs POE	10**	49
Tilford Eastbound	80	51
Tilford Westbound	87	54

*No dedicated truck parking at the rest area.

**Passenger vehicle parking dedicated to South Dakota Highway Patrol staff.

The results show that the Valley Springs Westbound Rest Area serves the most passenger vehicle parking of the seven observed sites during the study period. The 308 total visits is more than double the visits to the Homestead and Tilford Rest Areas. The two Hidewood Rest Areas had a similar amount of truck visits during the 24-hour period, which exceeded truck visits at the other facilities. Each of the other rest areas showed a similar number of parked trucks during the 24-hour period. Of note, the POE serves significantly more truck traffic than shown, as only a small portion of that traffic is required to park for extended periods of time.

The average parking occupancy for both passenger vehicles and trucks at each facility was analyzed to determine the adequacy of the existing parking facilities. The results were segregated by average daytime (7:00am to 6:00pm) and nighttime (7:00pm to 6:00am) parking occupancy to determine if vehicular parking needs differ throughout a typical day at these facilities. The results of the analyses are summarized in **Table 2**.

Table 2. Average Parking Occupancy Summary

Facility	Average Parking Occupancy			
	Daytime Hours		Nighttime Hours	
	Passenger Veh.	Trucks	Passenger Veh.	Trucks
Hidewood Northbound	11%	26%	3%	64%
Hidewood Southbound	10%	36%	17%	49%
Homestead	20%	11%	5%	24%
Valley Springs Westbound**	19%		4%	
Valley Springs POE	63%*	32%	0%	14%
Tilford Eastbound	13%	22%	9%	44%
Tilford Westbound	8%	13%	8%	23%

*Passenger vehicle parking dedicated to South Dakota Highway Patrol staff.

**No dedicated truck parking at the rest area.

The results of the analyses show, on average, during both the daytime and nighttime hours each rest area provides adequate capacity to handle the current parking demand. Average passenger vehicle occupancy was generally less than 20% at most facilities. In addition, demand for passenger vehicle parking reduced during the nighttime hours in most locations. The opposite is true of truck parking, which experiences increased demand during the nighttime hours. The exception is the POE, which operates only during the day and is typically not viewed as a desirable overnight parking location for truck drivers. Of note, during various hours of the day the demand for parking exceeds capacity in several locations. A detailed description of these issues are quantified in following sections of the report.

The duration in which vehicles are parked at each facility is a key metric to determine the average time vehicles are parked. At rest areas, parking duration varies based on the user. Typically passenger vehicles park at rest areas for short term needs (bathroom stops, brief rests), while trucks tend to park for longer periods of time for extended rest. The average duration of both passenger vehicles in trucks over the 24-hour collection period was calculated and summarized in **Table 3**.

Table 3. Average Parking Duration Summary

Facility	Average Parking Duration			
	Daytime Hours		Nighttime Hours	
	Passenger Veh.	Trucks	Passenger Veh.	Trucks
Hidewood Northbound	11 minutes	32 minutes	10 minutes	98 minutes
Hidewood Southbound	14 minutes	24 minutes	90 minutes	110 minutes
Homestead	187 minutes	57 minutes	52 minutes	293 minutes
Valley Springs Westbound**	30 minutes		23 minutes	
Valley Springs POE		44 minutes		720 minutes
Tilford Eastbound	29 minutes	41 minutes	67 minutes	288 minutes
Tilford Westbound	16 minutes	21 minutes	52 minutes	83 minutes

**No dedicated truck parking at the rest area.

In general, passenger vehicles are parked at rest areas for less time than trucks. The time vehicles are parked increases during the nighttime hours, especially so for truck traffic that experiences a significant increase in the amount of time a vehicle is parked. The duration of truck

parking during the nighttime increases between 2-15 times higher as compared to daytime operations.

The Homestead Rest Area also showed passenger vehicles parked longer than trucks during the daytime peak period. A review of the video showed that both visitor center employees and vehicles dedicated to on-site maintenance contributed to the higher duration. There were also two passenger vehicles that were parked for 18 consecutive hours, which contributed to the passenger vehicle duration calculations.

As stated previously, parking at some rest areas were shown to operate at or near the capacity threshold during portions of the day. In addition, parking conditions at each facility vary throughout the day and experience unique trends. To quantify these trends, the following bullets summarize conditions at each facility:

- **Hidewood Northbound** - Passenger vehicle parking occupancy operates well below the capacity threshold throughout the study period. During daylight hours, the maximum observed occupancy was 19%, which occurred during 12:00PM. Passenger vehicle parking during the nighttime hours was reduced significantly, as compared to the daytime peak. Truck parking occupancy was much higher, with several hours during the nighttime peak operating near or at the capacity threshold (90% or higher occupancy). In addition, video showed that four trucks parked in the passenger vehicle lot throughout the day and stayed anywhere from 15-minutes to over one hour. A summary of the hourly parking occupancy at the Hidewood Northbound Rest Area is shown on **Figure 1**.
- **Hidewood Southbound** - Passenger vehicle parking occupancy trends were opposite the Hidewood Northbound facility as occupancy was higher during the nighttime hours than the daytime. Parking occupancy peaked at 32% at 1:00AM, while the daytime peak was 13% from 9:00AM through 10:00AM. Truck parking occupancy operated near the capacity threshold during several nighttime hours and from 1:00PM through 3:00PM during the daytime. In addition, approximately ten trucks were shown to be parking in the passenger vehicle lot throughout the day. The vast majority stopped for less than twenty minutes, but two did stay overnight between five to ten hours. A summary of the hourly parking occupancy at the Hidewood Southbound Rest Area is provided in **Figure 2**.
- **Homestead** - The rest area provides the greatest total passenger vehicle and truck parking spaces of the seven sites studied in this report. Parking occupancies for both users were well below the capacity threshold throughout the 24-hour period. Passenger vehicle occupancy peaked during the daytime hours (28% at 12:00PM), while truck parking peaked during the nighttime (36% at 5:00AM). Parking conditions at the Homestead Rest Area are shown on **Figure 3**.
- **Valley Springs Westbound** - The rest area served the most number of parked vehicles of the seven sites observed for this study. Since the average time vehicles were parked was 30 minutes or less (see **Table 3**), parking occupancy operated well below the capacity threshold even with the higher volume of visitors. Occupancy also peaked mid-day, and significantly dropped off during the nighttime hours. Parking occupancy for the Valley Springs Westbound Rest Area is shown on **Figure 4**.

- **Valley Springs POE** - The facility, dedicated to the inspection of trucks and their operators, provides both passenger vehicle and truck parking. Passenger vehicle parking is dedicated to the South Dakota Highway Patrol and is fully occupied throughout the hours of operation. As opposed to a typical rest area, truck parking peaked during the daytime hours primarily due to inspections by Highway Patrol staff. Once the facility was closed, truck parking decreased with one vehicle parked throughout the entire nighttime peak. It is not anticipated that the truck was being operated at the time of the count, and remained parked either due to a violation or mechanical failure. Parking conditions at the Valley Springs POE are shown on **Figure 5**.
- **Tilford Eastbound** - Passenger vehicle parking peaked during the daytime hours (23% at 11:00AM) and operated well below the capacity threshold throughout the entire 24-hour period. Similar to other rest areas, truck parking peaked during the nighttime hours (57% at 1:00AM) and operated below the capacity threshold. As stated previously, the rest area provides nine parallel truck parking spaces, requiring trucks to complete complex turning movements to enter / exit parking spaces. Although truck parking occupancy was within capacity, the layout of the parking spaces could contribute to trucks either bypassing the site or driving through without parking due to the complex turning movements that would be required. A summary of the parking occupancy counts at the Tilford Eastbound Rest Area is shown on **Figure 6**.
- **Tilford Westbound** - Both passenger vehicle and truck parking demand remained within capacity during the study period. Truck parking peaked during the nighttime hours (51% at 1:00AM) and operated the remainder of the 24-hour period well under the capacity threshold. Of note, security video was used to supplement video data during the 3:00AM through 8:00AM time frame, which was not viewable. A summary of the parking occupancy counts at the Tilford Westbound Rest Area is shown on **Figure 7**.

FUTURE CONDITIONS

Future Use Projection Methodology

Determining how many vehicles will be parked in the facilities in the future is a key consideration in determining the adequacy of the on-site infrastructure. To determine future use projections, two separate steps were taken. First, the parking counts were adjusted to reflect seasonal increases in traffic experienced in South Dakota. The seasonally adjusted conditions were then projected to the future planning year. The following outlines the methodology used to develop these projections.

South Dakota is a popular tourist destination, particularly during the summer months, with destinations such as Mount Rushmore, the Badlands and the annual Sturgis Motorcycle Rally. Parking conditions at rest areas throughout South Dakota area can fluctuate based on the time of year (higher in the summer, lower in the winter) due to tourist related traffic and the weather. To account for these changes in travel patterns during a typical year, September 2013 parking counts at each rest area were adjusted to reflect peak conditions. Historical traffic counts at rest area automated traffic records (ATR's) or the mainline counts nearest the facility were used to adjust the existing parking counts to peak conditions. **Table 4** summarizes the seasonal factors at each rest area.

Table 4. Seasonal Adjustment Factors

Rest Area	Seasonal Adjustment Factor
Hidewood Northbound	1.1
Hidewood Southbound	1.1
Homestead	1.12
Valley Springs Westbound & POE	1.14
Tilford Eastbound	1.6
Tilford Westbound	1.6

After the base parking counts were adjusted to the peak condition, the adjusted counts were projected forward to the future year, assumed to be year 2040. Different methodologies were used for projecting passenger vehicle and truck traffic parking. For the passenger parking estimates, the *Highway Needs and Project Analysis Report*, South Dakota Department of Transportation, 2013 and the *South Dakota Decennial Interstate Corridor Study*, Felsburg Holt & Ullevig, 2010 were consulted. Growth rates in interstate traffic were used as tools to estimate passenger parking demand at each facility.

Each report was reviewed independently and the results compiled to develop the most conservative estimate of future use. The Needs Report provided current and 20-year traffic estimates on Interstate segments throughout the state. Growth rates on the interstate segments adjacent to each rest area contained in the Needs Report showed a consistent 0.72% increase per year, equating to a 16% increase in vehicular traffic between 2013 and 2040. The Decennial Interstate Corridor Study also provided growth rates on each section of interstate adjacent to the rest areas, which were based on information from SDDOT, population growth by county and historical forecasts through Metropolitan Planning Organizations (MPO). The rates in the Decennial Interstate Corridor Study varied on each Interstate corridor, and provided long term growth factors between 20% to 56%. Based on a comparison of various rates, the growth factors from the Decennial Interstate Corridor Study were used to determine long term (year 2040) passenger vehicle parking at each rest area. **Table 5** summarizes the results.

Table 5. Passenger Vehicle Parking Growth Factors

Rest Area	Yearly Growth Rate	2040 Growth Factor
Hidewood Northbound	1.32%	1.42
Hidewood Southbound	1.32%	1.42
Homestead	1.38%	1.45
Valley Springs Westbound & POE	2.16%	1.78
Tilford Eastbound	0.89%	1.27
Tilford Westbound	0.89%	1.27

Federal Highway Administration Freight Analysis Framework (FAF) (http://www.ops.fhwa.dot.gov/freight/freight_analysis/faf/) was used to develop long term truck parking estimates at each rest area. The FAF compiles data from various sources to develop a comprehensive national picture of freight movement among states and major metropolitan areas. As part of the freight movement estimates, long term truck volume projections are developed for each section of interstate and key state highways throughout the nation. These truck traffic projections were utilized to develop the long term truck parking estimates at each rest area. Truck traffic projections (year 2040) adjacent to each rest area were compared to existing FAF estimates to develop long term growth rates. **Table 6** summarizes the truck parking growth factors used in this report.

Table 6. Truck Parking Growth Factors

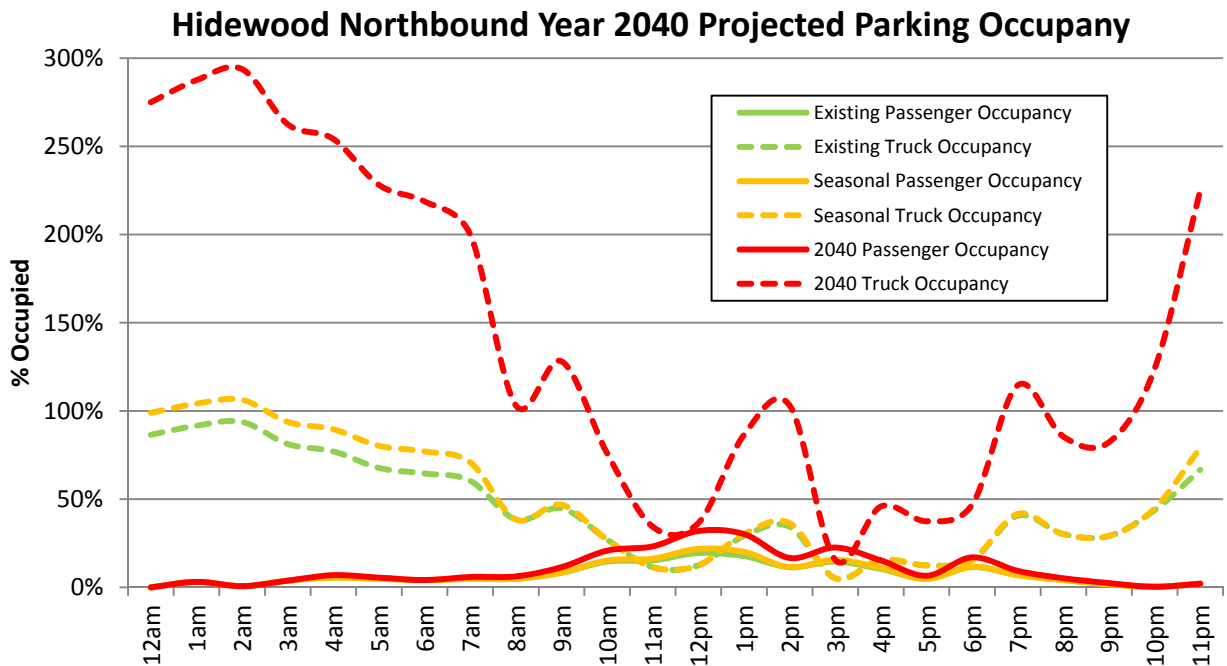
Rest Area	Yearly Growth Rate	Growth Factor
Hidewood Northbound	3.87%	2.8
Hidewood Southbound	3.87%	2.8
Homestead	2.64%	2.0
Valley Springs Westbound & POE	2.96%	2.2
Tilford Eastbound	3.08%	2.2
Tilford Westbound	3.08%	2.2

Note that truck growth is expected to exceed passenger vehicle growth through year 2014. Seasonal factors and the passenger vehicle or truck growth factors were applied to the existing parking counts to develop long term parking estimates. Future parking projections provide a conservative estimate of demand, as they represent future year peak season conditions. These long term parking estimates provide the basis determining the future use of each facility.

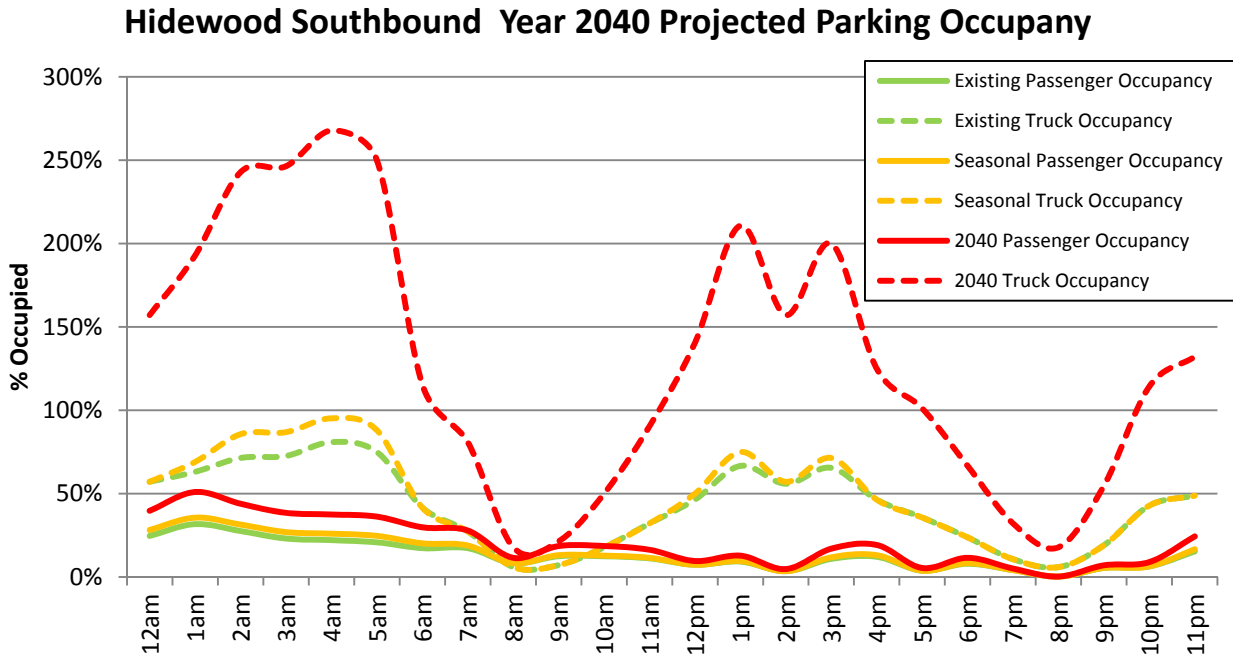
Rest Area Impact

The long term facility use estimates were applied to the existing parking occupancy count results (summarized in **Figure 1** through **Figure 7**) to determine long term parking demand. It was assumed that hourly variation in parking use remained constant through year 2040. Parking demand at each rest area is summarized in the following bullets.

- Hidewood Northbound** - The future use estimates show that the passenger vehicle parking will be adequately served by the existing allotment of parking spaces. Hourly passenger vehicle parking occupancy is projected to be less than 50% during all hours of the day. September 2013 truck parking at the rest area operates just under the existing capacity, and would operate over capacity when adjusting for seasonal peaks, To meet future year truck parking demand, the rest area would need to provide nearly 200% more truck parking spaces. A summary of the projected parking occupancy is shown on the following graph:

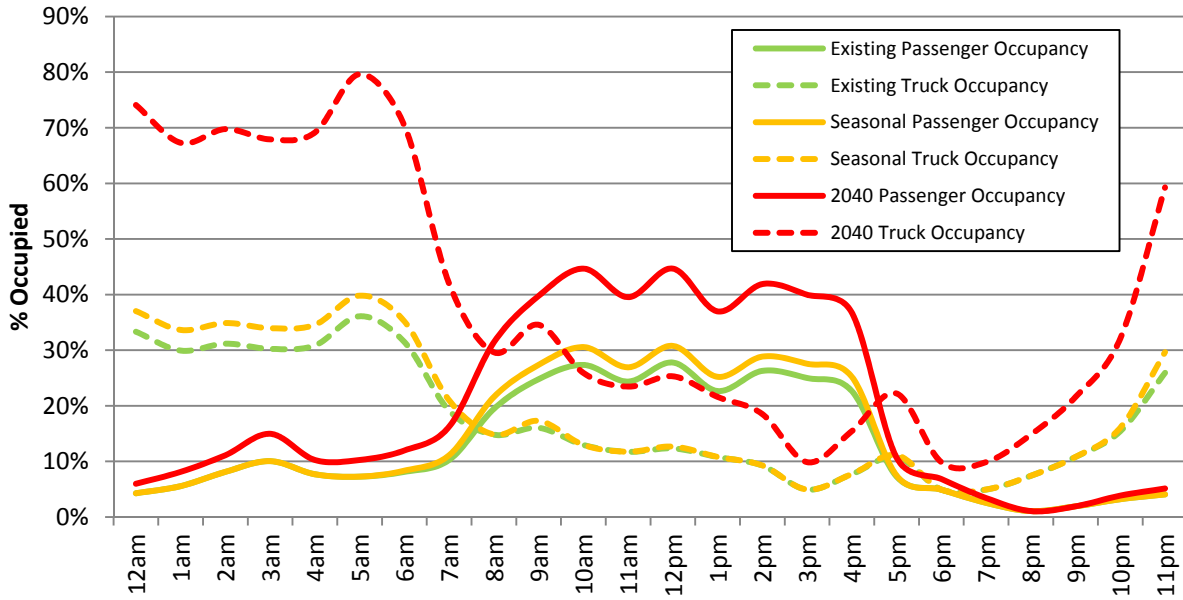


- Hidewood Southbound** - Similar to the Northbound location, passenger vehicle parking will be adequately served by the existing allotment of parking spaces at the Southbound Rest Area. Hourly passenger vehicle parking occupancy would operate at or below 50% occupancy during the day. To meet future year truck parking demand, the rest area would need to provide a 175% increase in truck parking spaces to meet both nighttime and daytime peaks. A summary of the projected parking occupancy is shown on the following graph:



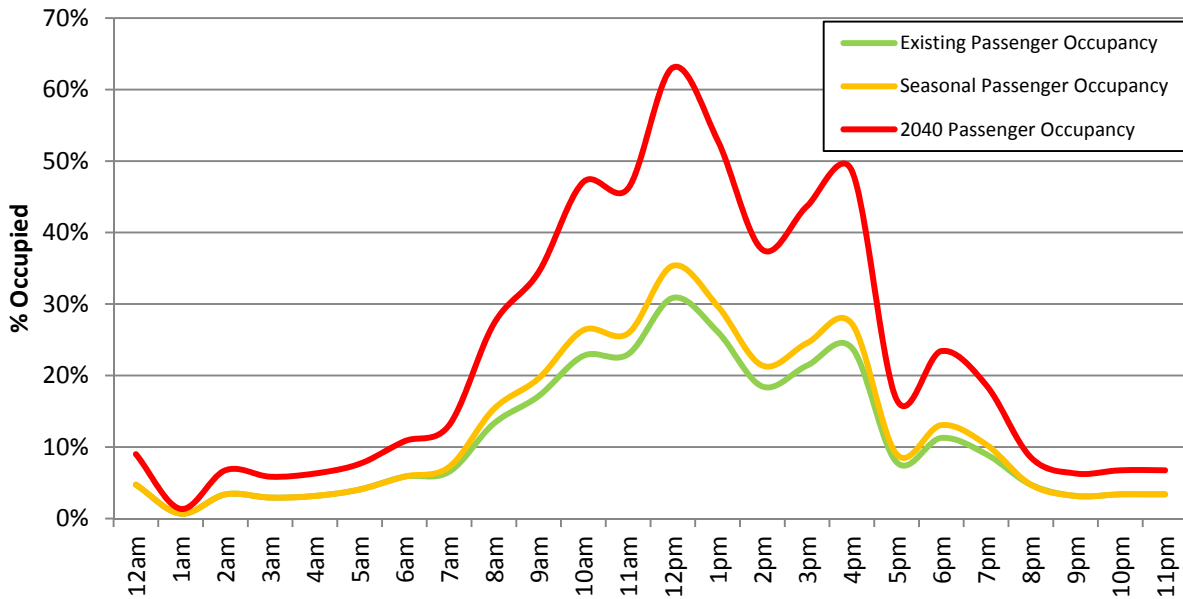
- Homestead** - The existing inventory of both passenger vehicle and truck parking spaces is anticipated to meet projected year 2040 demand. The rest area currently provides the highest number of both passenger vehicle and truck parking spaces. A summary of the projected parking occupancy is shown on the following graph:

Homestead Year 2040 Projected Parking Occupancy



- **Valley Springs Westbound** - As stated previously, the Valley Springs Rest Area has the highest number of visitors on a daily basis. Including both seasonal and future growth, it is anticipated that the existing parking capacity would be adequate to serve the future year 2040 demand. Parking occupancy is anticipated to operate well below the capacity threshold throughout the majority of a typical day. A summary of the projected parking occupancy is shown on the following graph:

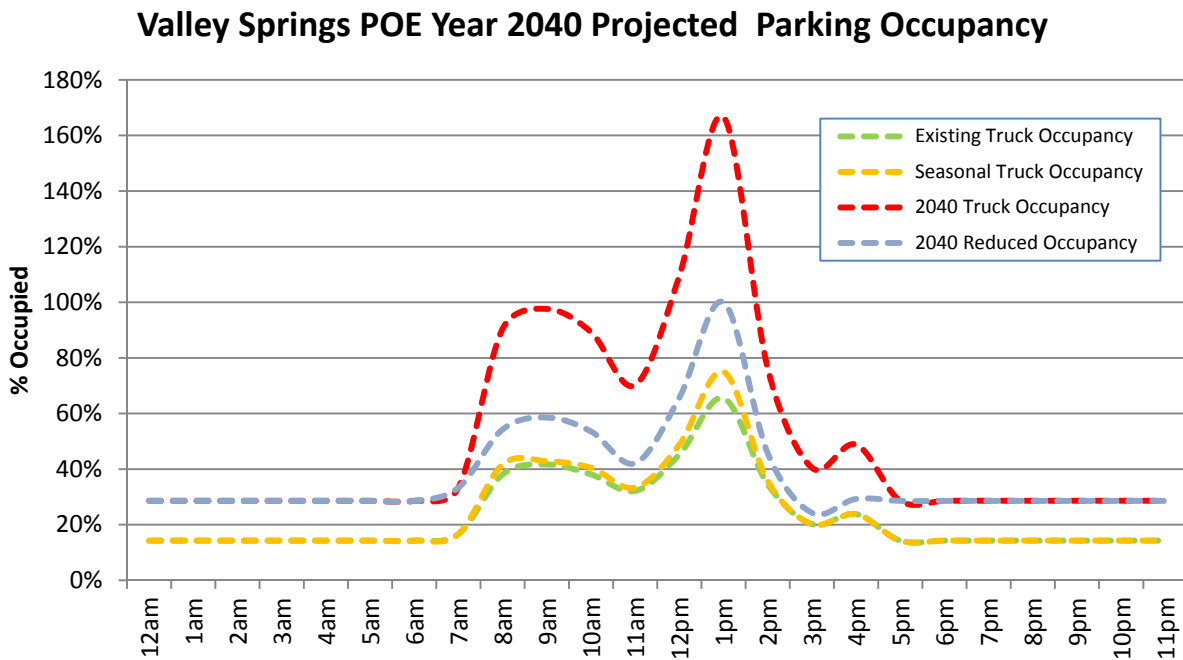
Valley Springs Year 2040 Projected Parking Occupancy



- Valley Springs POE** - The existing passenger vehicle parking is dedicated to South Dakota Highway Patrol staff, is not anticipated to grow, and therefore will not need to be expanded in the future (not shown on graph). Between now and the year 2040, truck traffic utilizing the POE is anticipated to increase by over 200%. Both the facility and the parking dedicated to the operation will need to be expanded to meet that need. However, future demand is only anticipated to significantly increase during the daytime hours when the facility is open, as truck operators prefer not to park overnight at the facility.

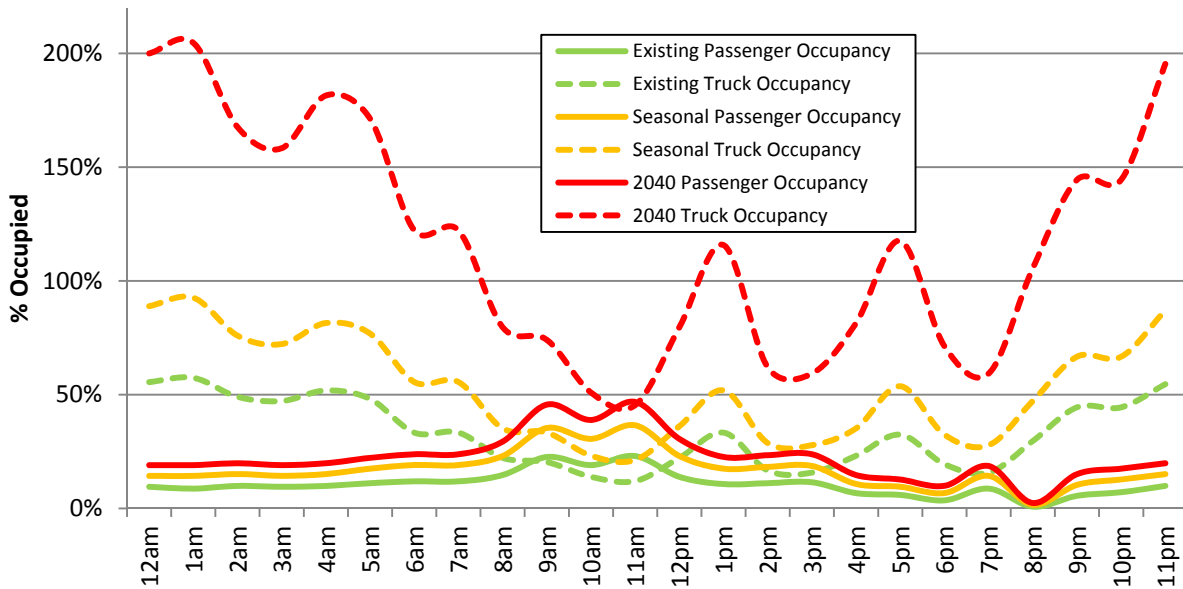
Based on discussions with SDDOT, in the future POE's throughout the State may be equipped with electronic metering capabilities. Drivewyze and license plate recognition software would be installed, and its estimated that as much as 60% of all truck traffic would be able to bypass the POE's throughout the state. Therefore, a second 2040 projection was added assuming electronic metering is installed at the POE. Based on the expected 60% reduction in truck traffic requiring inspection, the existing POE would be able to handle the projected parking demand through year 2040.

A summary of the projected parking occupancy is shown on the following graph:



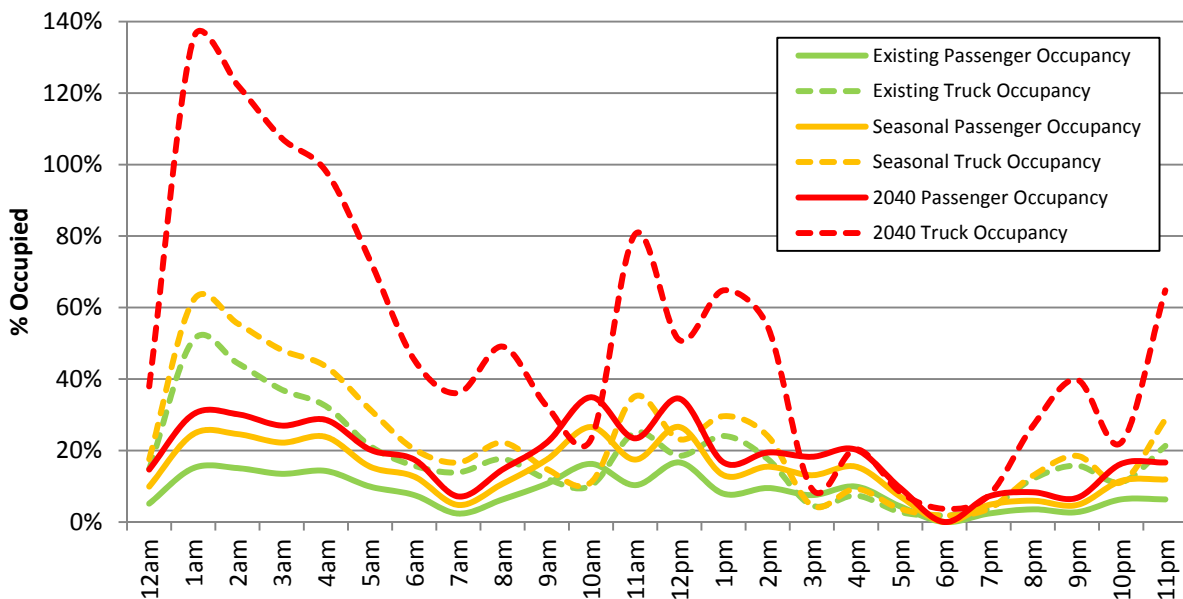
- Tilford Eastbound** - Passenger vehicle parking capacity is anticipated to meet long term demand, as the lot is anticipated to be less than 50% occupied through year 2040. Truck parking capacity would need to more than double current allotment to handle the future demand. A summary of the projected parking occupancy is shown on the following graph:

Tilford Eastbound Year 2040 Projected Parking Occupancy



- Tilford Westbound** - Similar to the Eastbound location, passenger vehicle parking will be adequately served by the existing allotment of parking spaces at the Westbound Rest Area. Also, truck parking is would need to increase almost 40% to meet future demand. A summary of the projected parking occupancy is shown on the following graph:

Tilford Westbound Year 2040 Projected Parking Occupancy



NEEDS ASSESSMENT

The results of the future use projections show at each rest area existing passenger car parking capacity would be adequate to handle future demand. Although visits are expected to increase through year 2040, the each facility provide adequate capacity to handle both daytime and nighttime passenger vehicle demand.

Truck parking capacity will need to be expanded at most rest areas in the future. Based on FHWA models, truck traffic will significantly increase through year 2040 on the Interstates in South Dakota, affecting parking. Hours of Service (HOS) regulations further drive the need for parking. The HOS regulations limit the total amount of time that a truck driver can operate the vehicle, and also specifies how much consecutive off-duty time is required prior to driving again. Once drivers reach their off-duty time, monitored electronically in most cabs, they are required to immediately find a place to stop regardless of the time of day or location. In addition, trucks park for a longer duration requiring additional parking to meet demand for a longer period of time. The following bullets summarize the expansion potential at each facility to meet future demand:

- **Hidewood Northbound** - Future estimates show parking would need to increase by 16 spaces, tripling existing capacity. The parking area currently provides eight head-in angled parking spots. The area directly north and south of the existing truck parking lot provides adequate room to expand the facility. It is anticipated that 17-21 truck parking spaces could be added with minimal impact to the existing infrastructure. **Figure 8** depicts the expansion potential for the facility.
- **Hidewood Southbound** - It is anticipated that the rest area would need to provide approximately 175% more truck parking spaces to meet demand. Similar to the Northbound Rest Area, the area north and south of the existing seven space parking facility could be expanded with minimal impact to the existing infrastructure. An estimated 14-27 additional parking spaces could be added, exceeding future demand. **Figure 9** shows the expansion potential for the facility.
- **Homestead** - As stated previously, the existing passenger vehicle and truck parking capacity is anticipated to meet future demand at this location. However, if demand does exceed projections in the future, the existing facility does provide area for expansion of the truck parking in the future. An additional five to ten angled truck parking spaces could be added along the western side of the site, and would require removal of existing trees to accommodate the additional pavement. **Figure 10** shows the expansion potential for the facility.
- **Valley Springs Westbound & POE** - It is anticipated that truck parking capacity would need to be expanded by almost 80% to meet future demand, only if electronic metering equipment is not installed. In addition, the POE facility may require expansion to fulfill its mission of inspecting trucks and their operators entering South Dakota. Compared to other POE's within South Dakota, the Valley Springs location is smaller and does not provide a covered inspection area. With improvements to the passenger vehicle and truck parking egress points onto Interstate 90, the POE facility could be expanded to include up to 100% of additional area that could be designated for either parking or vehicular inspection. **Figure 11** shows the expansion potential for the facility.

- Tilford Eastbound** - It is anticipated that truck parking would need to more than double to meet future demand. Given the location of the site, right-of-way and topography limits, the expansion potential of the rest area is limited. One alternative to increasing truck parking capacity would be to redesign the parking area to provide head-in angled truck parking, similar to the Homestead Rest Area. The parking lot would need to be expanded to the east, closer to the Interstate 90 corridor, and could provide a total of 16-18 truck parking spaces. It is recognized that the parking lot would interfere with the clear zone of the Interstate corridor, but barrier (guardrail, jersey barrier, etc.) could be added to meet clear zone criteria. **Figure 12** shows the expansion potential for the facility.
- Tilford Westbound** - Truck parking would need to be expanded by more than 40% to meet future demand. Similar to the Eastbound location, the Westbound Rest Area provides limited areas for expansion. Redesigning the parking lot to provide head-in angled truck parking could provide as many as 21 truck parking spaces, a 130% increase in capacity. The proximity of the expanded parking lot to the Interstate 90 corridor would require installation of barrier to meet clear zone criteria. **Figure 13** shows the expansion potential for the facility.

Table 7 provides an overview of truck parking needs to accommodate growth to the Year 2040 at each rest area. No expansion of truck parking is needed at the Homestead rest area.

Table 7. Truck Parking Growth Factors

Rest Area	Number of Truck Parking Spaces		
	Current	Additional Needed	Total Needed
Hidewood Northbound	8	16	24
Hidewood Southbound	7	12	19
Valley Springs POE ¹	7	5	12
Tilford Eastbound	9	10	19
Tilford Westbound	9	4	13

¹Based on discussions with SDDOT, in the future POEs throughout the State may be equipped with electronic pass capabilities, resulting in up to 60 percent of all truck traffic bypassing POEs. Therefore, a second 2040 projection was added assuming electronic metering is installed at the POE. Based on the expected 60 percent reduction in truck traffic requiring inspection, the existing POE would be able to handle the projected parking demand through year 2040.

PRIVATE FACILITY IMPACT

The influence of private truck stops in South Dakota has a direct impact on truck parking needs at rest areas throughout the state. Discussions were held with Myron Rau at the South Dakota Trucking Association (SDTA) to quantify the private truck stop influence on parking demand. The following bullets summarize the discussions:

- In general, truck drivers prefer to park for long durations at private truck stops due to the services that are provided (gas, fuel, security). These facilities are typically full every night and are now operating near capacity during the daytime hours as well. During adverse weather conditions, these facilities are highly desirable as they provide sustenance when roads are closed for significant amounts of time.
- Rest areas are typically regarded as a second tier for longer term truck parking needs, but are favored by some drivers as a primary parking location. The SDTA has not fielded many complaints from drivers regarding the existing capacity at the rest areas in the past.
- Hours of service (HOS) rules will drive the need for truck parking in the future. Due to electronic monitoring equipment, now standard in most trucks, once drivers hit the maximum driving time they must immediately stop for extended periods of rest regardless of their current location. Rest areas may play a more important role for truck parking if hours of service rules continue to become more restrictive.
- Due to the current restrictions on drive time and mandatory rest, drivers often plan their stops days in advance. Providing drivers with real-time parking availability at rest areas would be beneficial for truck drivers both when planning their trip and in the hours leading up to their stop.

Through the discussions, it is clear that the private truck stops provide a significant benefit to truck parking needs throughout the state. Without the additional parking capacity provided by these facilities, rest area truck parking would be operating well over the capacity threshold. For reference, **Figure 14** shows private truck stop locations throughout South Dakota. These locations were obtained from databases maintained by *The Truckers Friend, National Truck Stop Directory*, 2014.

The construction of new private truck stops and / or the expansion of existing facilities has the potential to reduce the need for truck parking at rest areas. However, with truck parking expected to more than double in some parts of South Dakota by year 2040, private facilities may not be able to meet the demand. It is anticipated that rest areas will continue to play a significant role in truck parking well into the future.

CONCLUSION AND RECOMMENDATIONS

In support of the Interstate Rest Areas Study, an analysis of parking conditions at each rest area facility was completed. The purpose of the analysis was to quantify existing passenger vehicle and truck parking conditions at each facility, project parking conditions to a future long term horizon, and determine if each facility would need to be expanded to meet the future parking needs.

The existing parking counts (summarized in **Figure 1** through **Figure 7**) show that each facility provides adequate passenger parking capacity to meet current daytime and nighttime demand.

The counts also show that truck parking at some rest areas operates at or near the capacity threshold during portions of the 24-hour count.

Year 2040 use projections at each rest area were reached by adjusting existing parking counts to peak season conditions, and applying growth factors from several data sources including the *Highway Needs and Project Analysis Report*, South Dakota Department of Transportation, 2013, the *South Dakota Decennial Interstate Corridor Study*, Felsburg Holt & Ullevig, 2010 and the Federal Highway Administration Freight Analysis Framework (FAF). Results of the future year projections show that most rest areas will need to be expanded in the future to meet anticipated truck parking demands.

Each rest area facility was studied to determine the potential for expansion. Based on the analysis, it is anticipated the each facility can be expanded to meet future demand with minimal impacts to existing infrastructure.

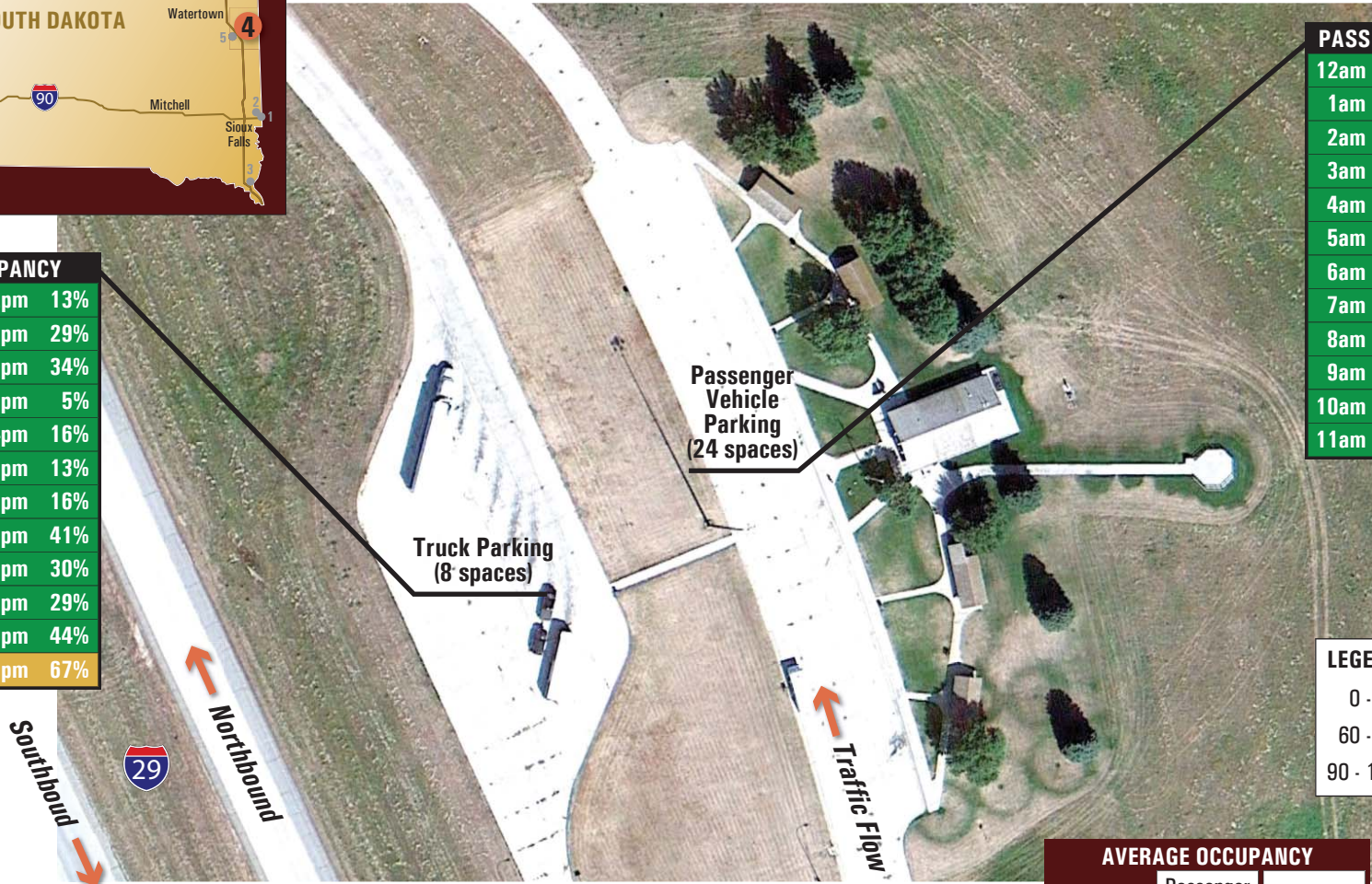


TRUCK OCCUPANCY




12am	86%	12pm	13%
1am	92%	1pm	29%
2am	94%	2pm	34%
3am	81%	3pm	5%
4am	77%	4pm	16%
5am	68%	5pm	13%
6am	65%	6pm	16%
7am	60%	7pm	41%
8am	39%	8pm	30%
9am	45%	9pm	29%
10am	27%	10pm	44%
11am	11%	11pm	67%

PASSENGER OCCUPANCY

12am	0%	12pm	19%
1am	3%	1pm	18%
2am	1%	2pm	11%
3am	4%	3pm	15%
4am	6%	4pm	10%
5am	5%	5pm	5%
6am	4%	6pm	11%
7am	5%	7pm	7%
8am	5%	8pm	4%
9am	8%	9pm	2%
10am	15%	10pm	0%
11am	15%	11pm	2%



LEGEND

0 - 59%	Occupied	
60 - 89%	Occupied	
90 - 100%	Occupied	

AVERAGE OCCUPANCY

	Passenger Vehicles	Trucks
Daytime	11%	26%
Nighttime	3%	64%



Figure 1. Hidewood Northbound Rest Area Parking Occupancy

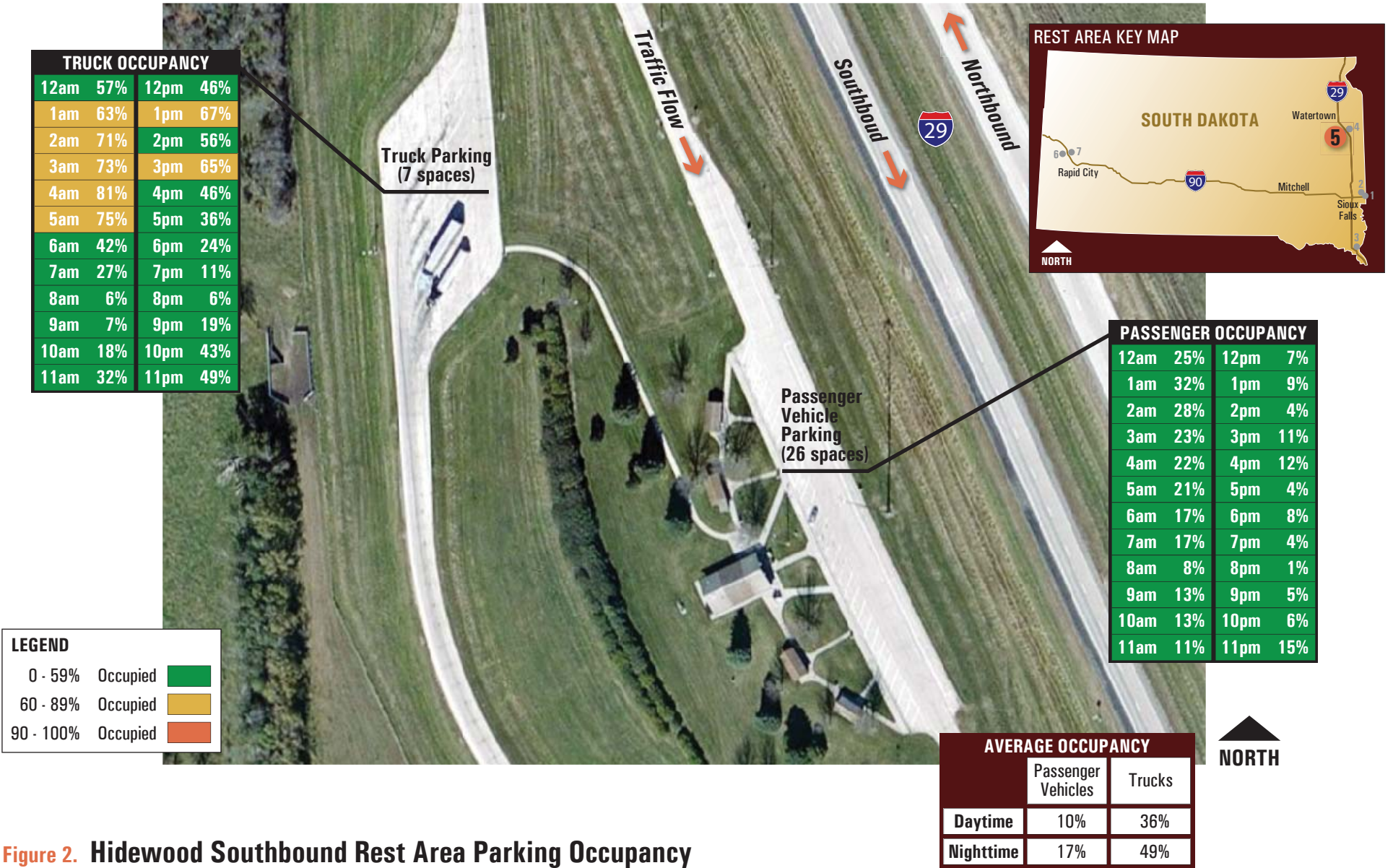





Figure 2. Hidewood Southbound Rest Area Parking Occupancy

REST AREA KEY MAP



PASSENGER OCCUPANCY			
12am	4%	12pm	28%
1am	6%	1pm	23%
2am	8%	2pm	26%
3am	10%	3pm	25%
4am	8%	4pm	23%
5am	7%	5pm	7%
6am	8%	6pm	5%
7am	10%	7pm	3%
8am	19%	8pm	1%
9am	25%	9pm	2%
10am	27%	10pm	3%
11am	24%	11pm	4%

TRUCK OCCUPANCY			
12am	33%	12pm	12%
1am	30%	1pm	11%
2am	31%	2pm	9%
3am	30%	3pm	5%
4am	31%	4pm	8%
5am	36%	5pm	11%
6am	31%	6pm	5%
7am	19%	7pm	5%
8am	15%	8pm	7%
9am	16%	9pm	11%
10am	13%	10pm	15%
11am	12%	11pm	26%

LEGEND		
0 - 59%	Occupied	
60 - 89%	Occupied	
90 - 100%	Occupied	




AVERAGE OCCUPANCY		
	Passenger Vehicles	Trucks
Daytime	20%	11%
Nighttime	5%	24%

Figure 3. Homestead Rest Area Parking Occupancy

REST AREA KEY MAP

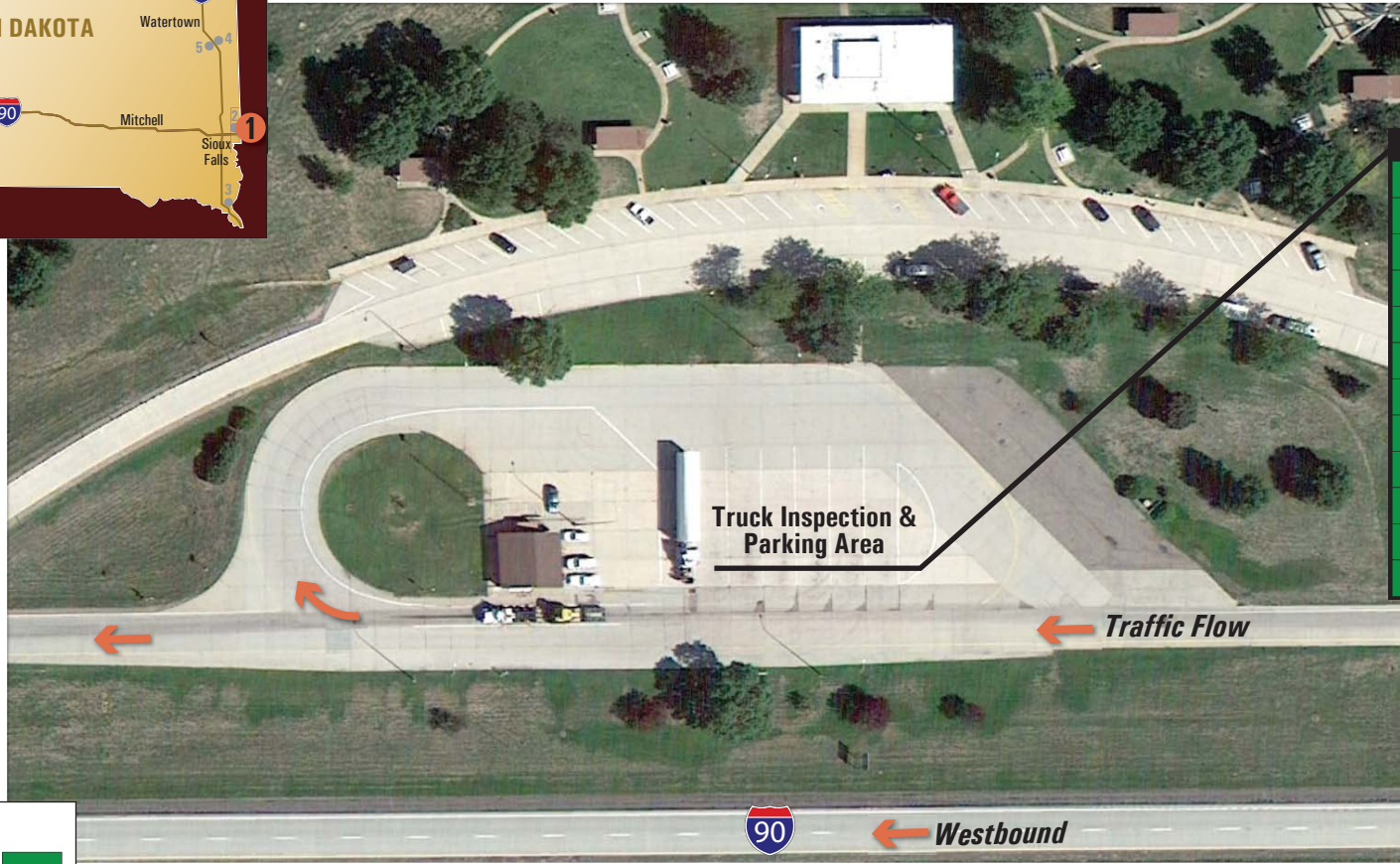


PASSENGER OCCUPANCY			
12am	5%	12pm	31%
1am	1%	1pm	26%
2am	3%	2pm	18%
3am	3%	3pm	21%
4am	3%	4pm	24%
5am	4%	5pm	8%
6am	6%	6pm	11%
7am	7%	7pm	9%
8am	13%	8pm	5%
9am	17%	9pm	3%
10am	23%	10pm	3%
11am	23%	11pm	3%




LEGEND		
0 - 59%	Occupied	
60 - 89%	Occupied	
90 - 100%	Occupied	

AVERAGE OCCUPANCY	
	Passenger Vehicles
Daytime	19%
Nighttime	4%

Figure 4. Valley Springs Westbound Rest Area Parking Occupancy



TRUCK OCCUPANCY			
12am	14%	12pm	45%
1am	14%	1pm	65%
2am	14%	2pm	35%
3am	14%	3pm	20%
4am	14%	4pm	24%
5am	14%	5pm	14%
6am	14%	6pm	14%
7am	17%	7pm	14%
8am	38%	8pm	14%
9am	42%	9pm	14%
10am	38%	10pm	14%
11am	32%	11pm	14%

LEGEND		
0 - 59%	Occupied	
60 - 89%	Occupied	
90 - 100%	Occupied	

AVERAGE OCCUPANCY	
	Trucks
Daytime	32%
Nighttime	14%

Figure 5. Valley Springs Port of Entry Site Parking Occupancy

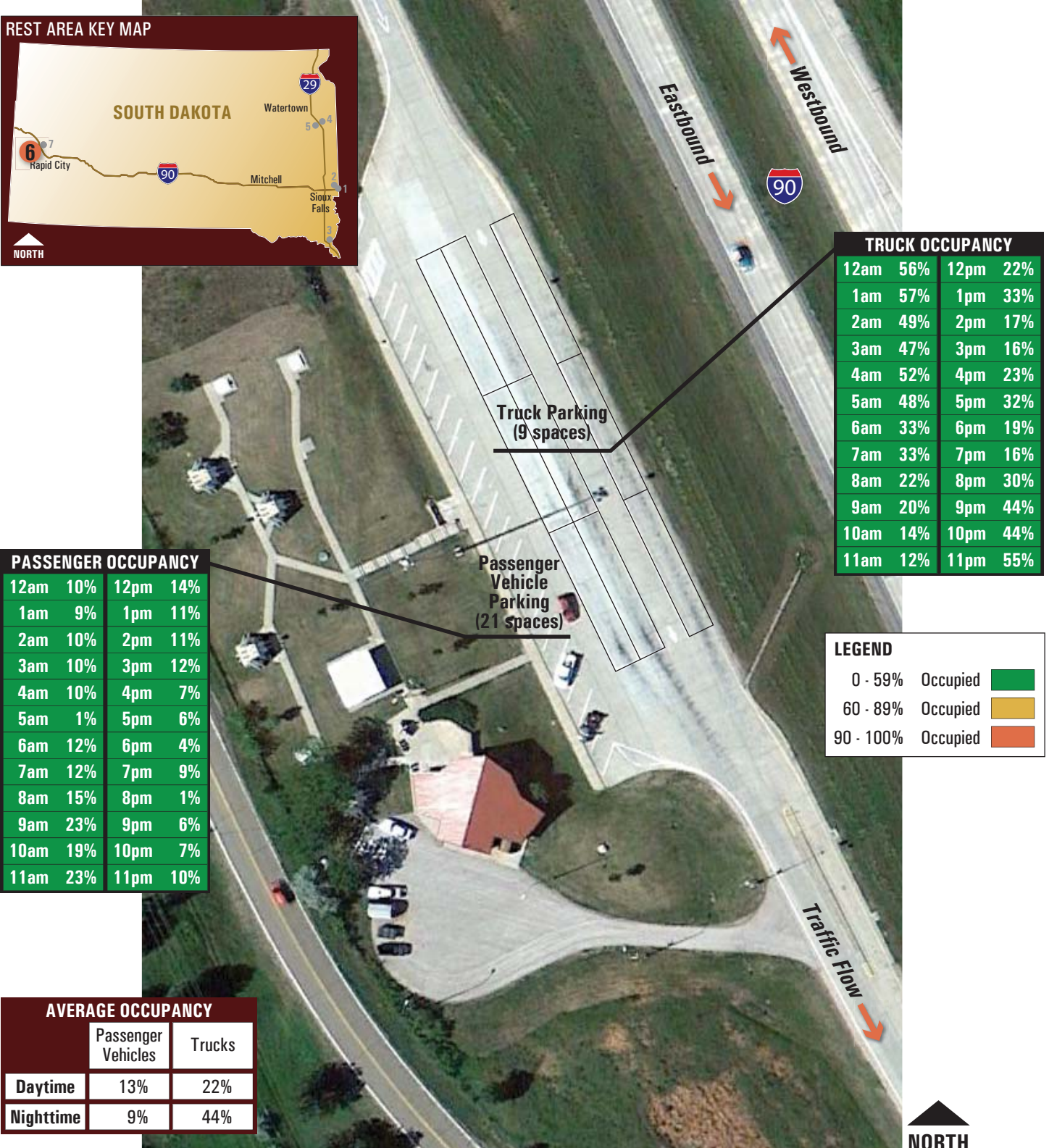


Figure 6. Tilford Eastbound Rest Area Parking Occupancy

LEGEND

0 - 59%	Occupied	
60 - 89%	Occupied	
90 - 100%	Occupied	

TRUCK OCCUPANCY

12am	15%	12pm	19%
1am	51%	1pm	24%
2am	44%	2pm	18%
3am	37%	3pm	5%
4am	32%	4pm	7%
5am	21%	5pm	3%
6am	16%	6pm	2%
7am	14%	7pm	4%
8am	18%	8pm	12%
9am	12%	9pm	16%
10am	10%	10pm	11%
11am	25%	11pm	21%

PASSENGER OCCUPANCY

12am	5%	12pm	17%
1am	15%	1pm	8%
2am	15%	2pm	10%
3am	13%	3pm	8%
4am	14%	4pm	10%
5am	10%	5pm	4%
6am	8%	6pm	0%
7am	2%	7pm	2%
8am	6%	8pm	4%
9am	11%	9pm	3%
10am	16%	10pm	6%
11am	10%	11pm	6%



AVERAGE OCCUPANCY

	Passenger Vehicles	Trucks
Daytime	8%	13%
Nighttime	8%	23%

Figure 7. Tilford Westbound Rest Area Parking Occupancy

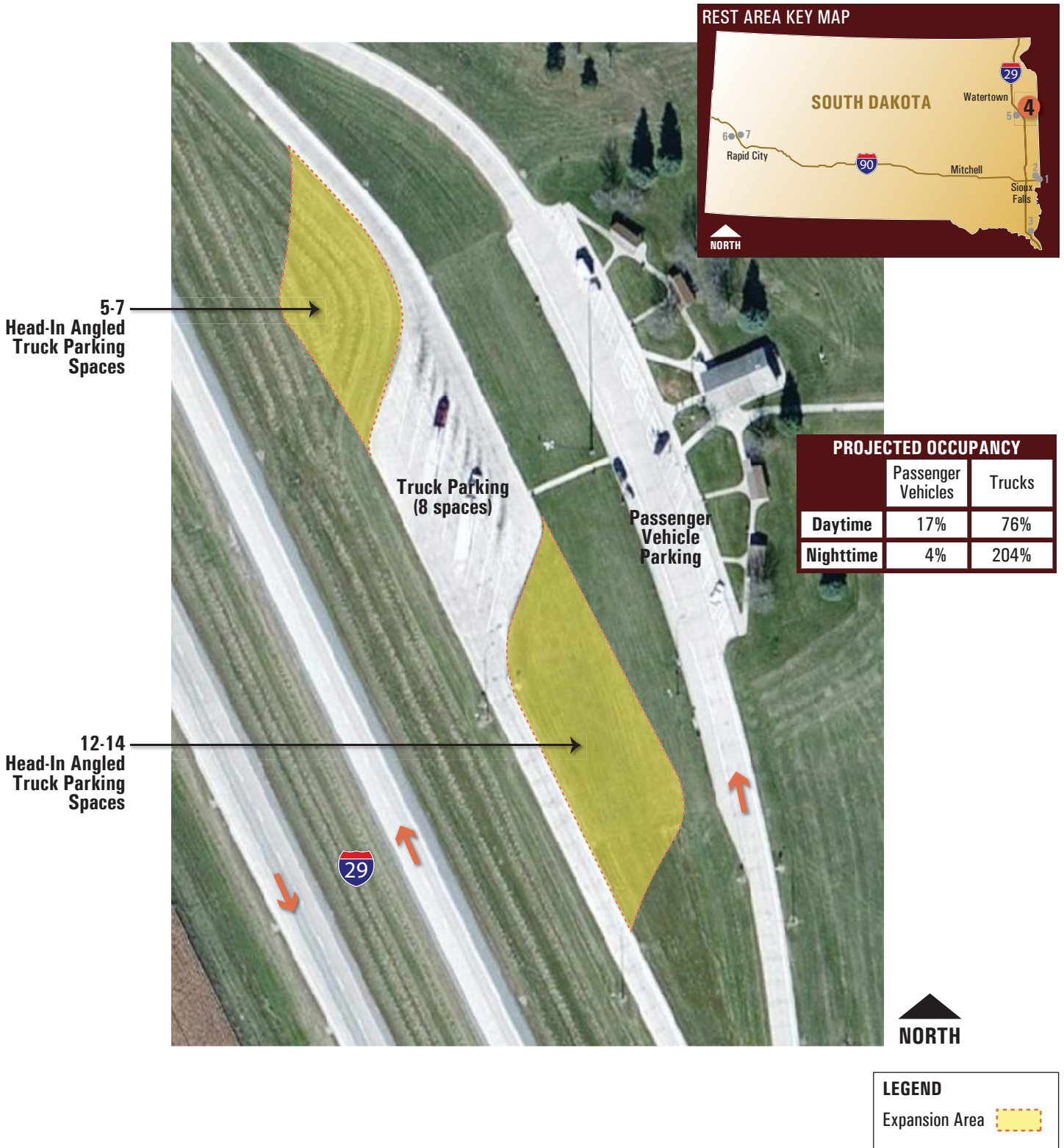
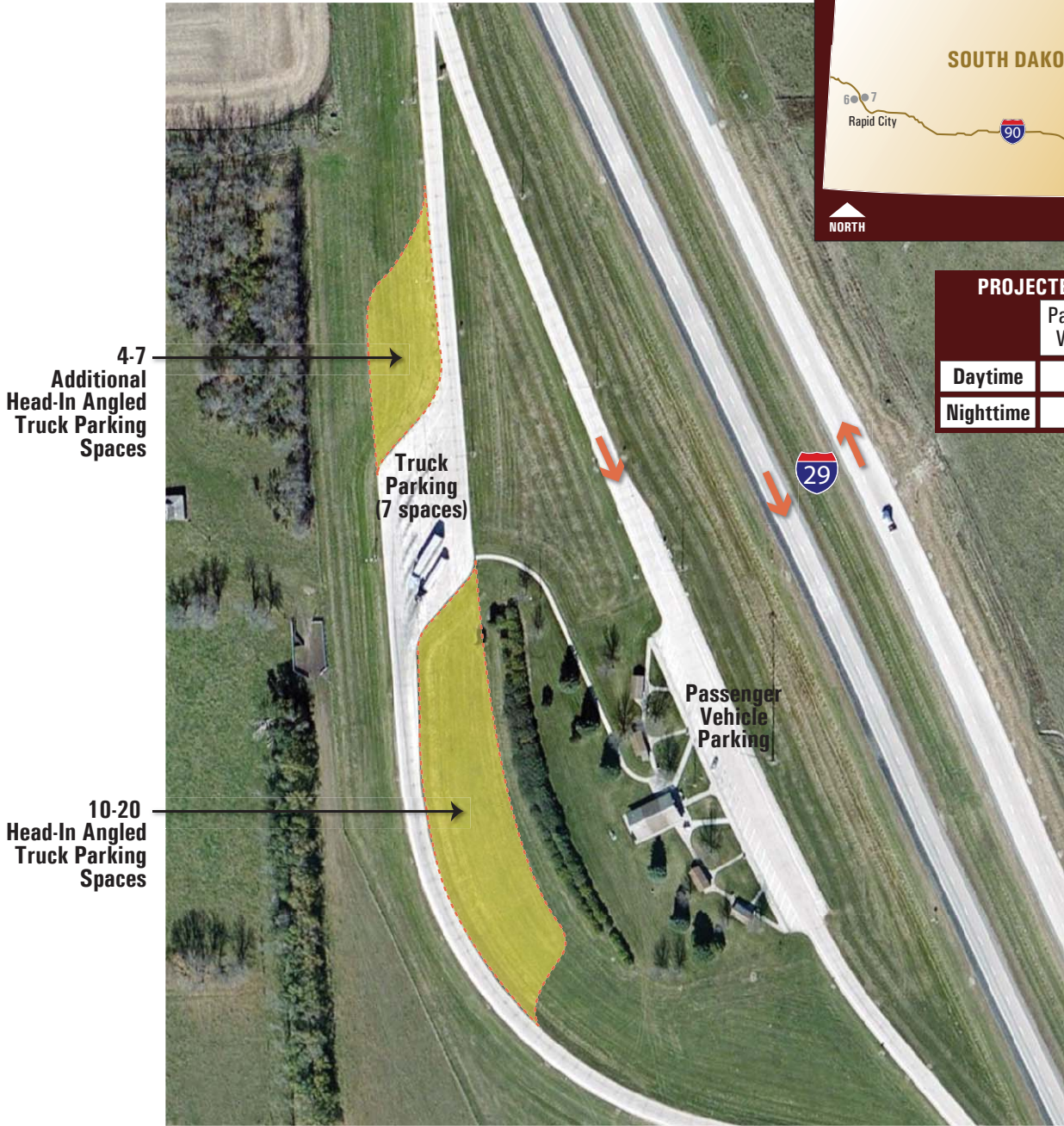


Figure 8. Hidewood Northbound Rest Area Future Expansion Potential



PROJECTED OCCUPANCY		
	Passenger Vehicles	Trucks
Daytime	14%	105%
Nighttime	27%	152%

LEGEND	
Expansion Area	

Figure 9 . Hidewood Southbound Rest Area Future Expansion Potential

REST AREA KEY MAP



LEGEND

Expansion Area 

PROJECTED OCCUPANCY

	Passenger Vehicles	Trucks
Daytime	32%	23%
Nighttime	7%	53%

Figure 10. Homestead Rest Area Future Expansion Potential

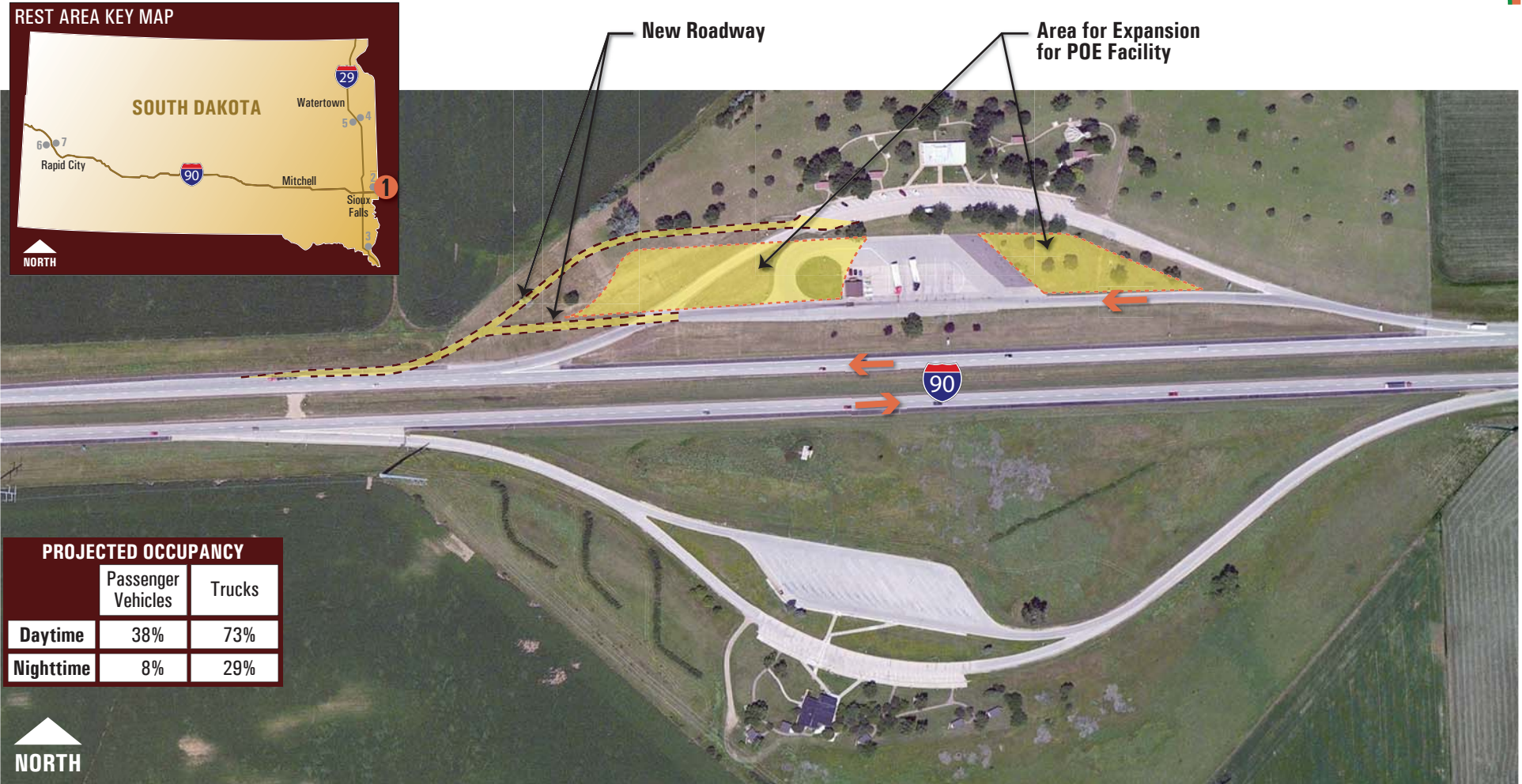


Figure 11. Valley Springs Sites Future Expansion Potential

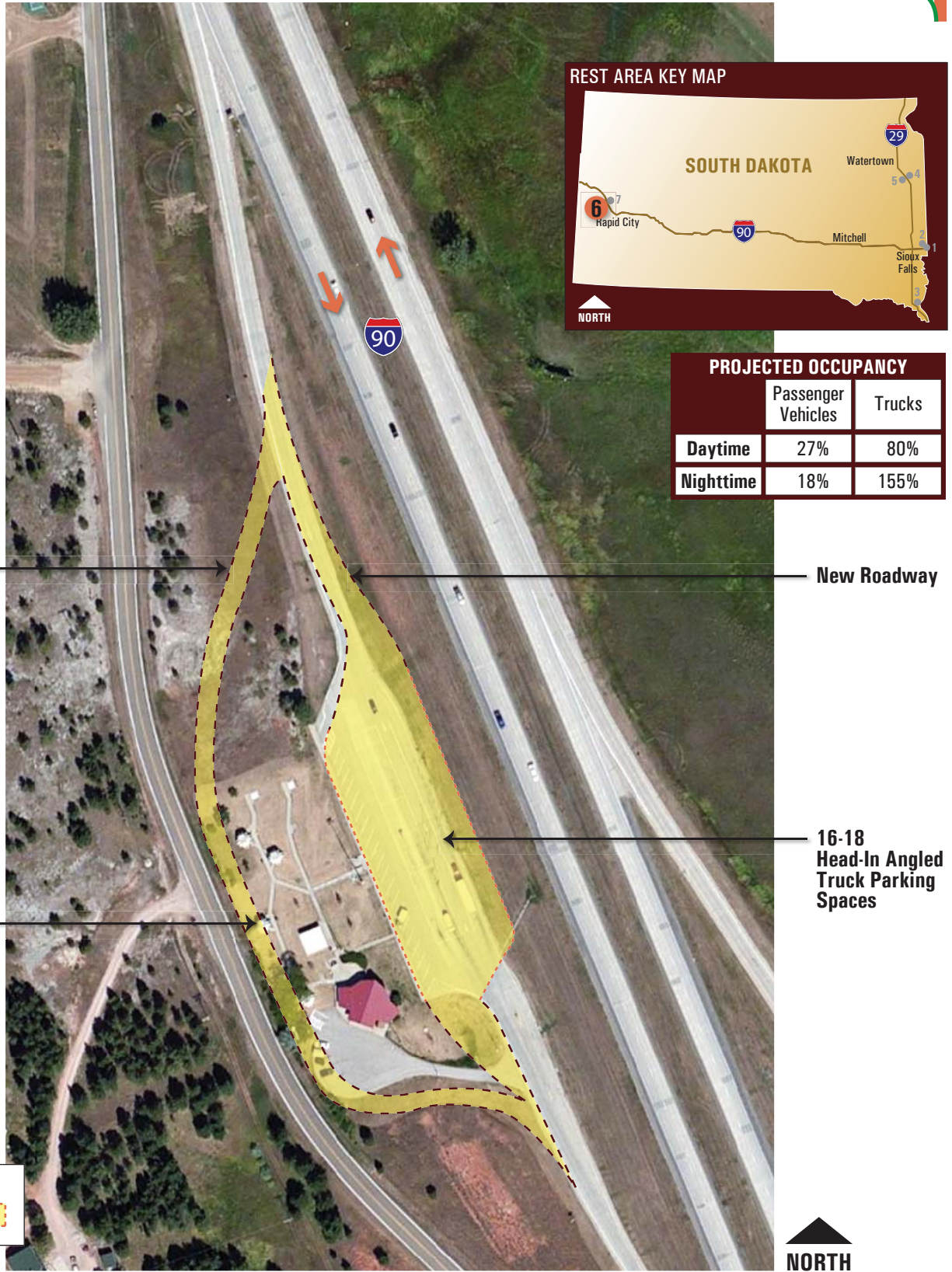


Figure 12. Tilford Eastbound Rest Area Future Expansion Potential



Figure 13. Tilford Westbound Rest Area Future Expansion Potential



Figure 14. Private Truck Stop Locations





April 28, 2014

MEMORANDUM

TO: Brad Remmich
SDDOT Transportation Planner

FROM: Timothy Roach, AIA
Jeremy Hahn, PE, PTOE

SUBJECT: SDDOT Interstate Rest Area Study
Technical Memorandum #4 – Valley Springs Needs Assessment
FHU Reference No. 113039-01

In support of the Interstate Rest Areas Study, included is an analysis of the future needs at the Valley Springs Rest Area. The purpose of the analysis is to quantify future needs at the rest area for five year planning horizons starting in year 2020. The following sections detail future use estimates at the rest area, and the improvements necessary to meet anticipated demand.

FUTURE USE CALCULATIONS

Determining the future use at each facility is based on the methodology contained in *Technical Memorandum #3-Parking Conditions Summary*. The analysis procedure estimated the growth in both passenger vehicles and truck traffic and developed long term parking estimates at each facility for the peak season. **Table 1** summarizes the growth in traffic estimated at the Valley Springs facility. Note that this as this facility services truckers parked at the neighboring Valley Springs POE the Truck parking figures are included in evaluating the capacity of the facility.

Table 1. Parking Growth Estimates

User Type	Existing Parked Vehicles	Seasonal Factor	Year 2040 Growth Factor	Year 2040 Parked Vehicles
Passenger Vehicles	308	1.14	1.78	625
Trucks (@POE)	49	1.14	2.2	123

The parking growth estimates show that passenger vehicle parking is anticipated to increase at an average rate of 2.16% per year, while truck parking would increase at a 2.96% yearly growth rate. Overall, the analysis indicates that daily users will significantly increase, and that the shift to servicing truck drivers, who are predominantly male, could drive the need for enhancing the men's restroom facilities.

Using the previous parking projections, occupant load calculations were developed. A key factor is determining the number of occupants in each vehicle. In the memorandum *1992 Safety Rest Area Usage Survey Reports*, 1992, Minnesota Department of Transportation, a user survey of motorists at the Marion Rest Area in Minnesota identified an average of 2.3 persons per vehicle. For the

analysis, the 2.3 persons per vehicle occupancy rate was applied only to passenger vehicles. In addition, it was assumed that the number of male and female occupants would be even.

Truck occupancy is anticipated to be far less, as most trucks have only a single driver. For purposes of this analysis, a 1.5 persons per vehicle occupancy rate was used for truck parking which accounts for tandem truck drivers and recreational vehicles. Currently, around 93% of truck drivers are male, but the number of female drivers is expected to increase in the future (<http://gobytrucknews.com/female-truckers-growing-in-number/>). To remain conservative, an 80/20 mix of male to female users was applied to the truck parking to account for an increase in female truck drivers and recreational vehicles which have a higher number of female passengers. **Table 2** provides a summary of the occupant load calculations at the rest area.

Table 2. Daily Occupant Load Summary

User	Existing Vehicles (peak)	Year 2040 Vehicles	Occupancy Factor	Existing Occupants	Year 2040 Occupants
Passenger Vehicles	353	625	2.3 per/veh.	812 (M=406, F=406)	1,436 (M=718, F=718)
Trucks	56	123	1.5 per/veh.	84 (M=67, F=17)	185 (M=148, F=37)
Totals				896 (M=473, F=423)	1,621 (M=866, F=755)

M=Male
 F=Female

Peak period use of the facilities was derived from hourly parking occupancy rates contained in the Parking Conditions memorandum. By analyzing the 24-hour parking occupancy percentages of both passenger vehicles and trucks in the Parking Conditions memorandum (see parking occupancy graphs: *Technical Memorandum #3 – Parking Conditions Summary*), the peak hour use of the facility can be determined for the existing and year 2040 horizons. **Table 3** summarizes the peak occupant loading of the facility.

Table 3. Peak Hour Occupant Load Summary

User	Existing Conditions	Year 2040 Conditions
Male	21	40
Female	16	29

The results show that occupant loads during a typical day are expected to nearly double between now and year 2040 at the Valley Springs Rest Area. In addition, peak hourly use of the facility is also expected to increase significantly between now and year 2040.

Using the occupant load estimates, an estimate on capacity of restrooms was developed. It was assumed that the design capacity of one toilet is eight persons per stall per hour. In addition, the existing rest area provides a total of six men’s and five women’s toilets, and it was assumed that in the future one toilet would be removed from each rest room to meet ADA requirements. Using the total number of toilets and peak hour occupant load estimates from **Table 3**, restroom capacity was developed for the two planning horizons. **Table 4** summarizes the capacity calculation.

Table 4. Restroom Capacity Calculation

User	Existing			Year 2040		
	Stalls	Peak Load	Capacity	Stalls	Peak Load	Capacity
Male	6	21	48	5	40	40
Female	5	16	40	4	29	32

The results show the rest area is currently functioning well under design capacity at roughly 50%-52% of total peak period capacity, which assumes the loss of two stalls. By 2040, the men’s and women’s restrooms will be operating at or near capacity.

Finally, the lagoon system serving the rest area was also reviewed. The lagoon is in need of service repairs/relining by 2020. According to current data, the facility is currently operating (at peak season) well under capacity and should be able to accommodate the projected increase in users until 2040. At the time the rest area is expanded in the future, the lagoon system should be evaluated to determine if lagoon expansion is necessary to support future use estimates.

FACILITY NEEDS

Through the facility assessments, meetings with SDDOT maintenance staff and future use calculations, a list of facility needs was developed. The needs address numerous issues found during the facility assessments including ADA compliance, building code conformity and overall functionality. These improvements were phased in five year horizons, starting with the five year period ending in 2020.

Per the *Technical Memorandum #3-Parking Conditions Summary*, there is sufficient vehicle parking provided for autos/RV’s to meet projected 2040 year demand. Also, refer to *Technical Memorandum #4 – Valley Spring Needs Assessment for truck parking requirements*.

Concerning the ADA requirements, both site and building improvements will be required to make the facility and the restrooms accessible to the public per ADA minimum standards. The two following options were developed to provide modifications to the interiors to create sufficient access routes into the restrooms and to create wheelchair accessible stalls:

- This can be achieved by widening the existing interior vestibules to the restrooms, and by converting a pair of toilet stalls to a single larger accessible stall. This upgrade approach will likely result in the loss of one toilet stall each for the men’s and women’s restrooms. This is the selected approach taken for this report as the facility is currently operating significantly under capacity
- As an option, to avoid the loss of capacity (stalls), a larger project would be required. The restrooms could be expanded by an addition to the front of the building to include the vestibule and possible space for family restrooms as well. Given the limited lobby size and minimal general circulation aisles, this expansion approach has more long-term usability potential.

The following sections describe improvements to the facility in five year increments starting in year 2020 through year 2040:

Year 2020

The facility was constructed in 1973 and is in need of a significant renovation to provide ADA upgrades and to refurbish the aged infrastructure. With this renovation the service life of the facility can be extended to 2040 when it will be nearing capacity, and will be ready for replacement. The following summarize the 2020 horizon improvements:

- Code Improvements (IBC 2012):
 - Provide GFI power outlets, and additional power outlets.
 - Provide HVAC system & new exhaust system (see mechanical notes).
 - Remove and replace storage areas not meeting 36" clearance near electrical panels.
 - Provide standing drinking fountain for wheelchair accessibility.
- Site required (ADA) Improvements
 - Address steep grade issues at parking lot, and the access walkway from building:
 - Demo, raise/re-grade and rebuild general area of the parking lot that includes the handicapped parking spaces, to meet the slope limits of the ADA (including sidewalks & curb cuts).
 - Raise and replace HC ramp with new 1:12 slope to access building entrance.
 - Replace accessible parking signs to meet ADA and MUTCD requirements.
 - Re-stripe accessible spaces to meet ADA standards.
 - Modify an additional exterior picnic bench for accessibility.
- Building (ADA) Improvements
 - Replace main entrance doors, closers and hardware.
 - Provide new general interior signage to replace existing signs that meet current ADA standards.
 - Provide new public phone unit with sound control, TTY plug in, and shelf.
 - Rebuild sink counters to ADA height.
 - Insulate pipes at sinks.
 - Reset soap dispensers above the lavatory counter below 44 inches above the floor.
 - Modify and update information counters.
 - Plan modifications for the restroom and restroom entries are required to provide for minimum interior clearances of the ADA. To achieve these requirements there are multiple options that could be considered by SDDOT. However, considering only the ADA, as the facility is currently operating well under capacity, the lower cost alternatives below are recommended (note this approach will be at the loss of 2 stalls and mechanical/storage space). The proposed modifications are as follows:
 1. *Per ADA, where doors are provided wider aisle widths are required (52"-58). Restroom entry doorways are too narrow at 36" and need to be widened with new partitions, doors, and hardware. (As a temporary option, prior to construction, the actual doors could be removed to meet the ADA, which then only requires a minimum 36" corridor width -however there are ventilation, privacy and line of sight concerns). This approach will require expansion internally into each restroom.*

2. Each restroom will require the addition of 5' accessible stalls. To do so can simply be achieved by removing a stall and expanding into it, however at the loss of one stall each for men's and women's. The new stalls will need to be properly modified with new handrails, properly placed accessories, and self-closing doors. Also, toilet locations should be adjusted to between 16" & 18" from side partition
- Information counter needs to be rebuilt to accommodate an ADA user with the required clearances, heights, and hardware.
- Site Systems
 - Provide lagoon system scheduled upgrades.
 - Replace the lawn irrigation system and all of its components.
 - Re-open dump station by providing the lid modifications at station.
 - Modify exit ramp slope and widen curb and gutter.
 - Repair deteriorating joint seals and spalling.
 - Repair parking area at large crack and accessible parking. Provide proper joint spacing of the new concrete to reduce the occurrence of longitudinal cracking.
 - Provide additional concrete pavement panel replacement 10%.
 - Replace sidewalk in area of accessible parking spaces and along entire parking area.
 - Repair 10% sidewalks, and completely at teepee.
 - Seal cracks in asphalt shoulders and apply seal coat.
 - Remove and replace asphalt where too badly cracked to seal (5%).
 - Replace outdoor parking, building and pedestrian lighting with new energy efficient fixtures.
 - Provide a routine structural inspection and possible repairs on lodge pole teepee given age of facility.
 - Refurbish existing picnic shelters; provide steel decking repairs, refinishing, and incidental masonry repairs.
 - Building System
 - Upgrade storage garage with maintenance repairs (roofing, painting, possible overhead and access door replacement)
 - Renovate existing Main Facility including:
 - General exterior masonry minor repairs, tuck-pointing, clean and seal.
 - Provide gutters and downspouts.
 - Upgrade/complete insulation of facility.
 - Provide insulating glass replacement at storefronts, and at windows at restrooms.
 - Replace service doors and hardware.
 - Replace roofing system.
 - General heavy cleaning and replace interior finishes including walls, ceilings, flooring, counters/cabinetry, and partitions.
 - Interior Paint and new flooring.
 - New ceiling system (with new HVAC and new lighting)
 - General refinishing of interiors (walls, ceilings, flooring, counters/cabinetry, partitions).

- Repair and repaint exposed concrete roof structure.
- Plumbing System:
 - Use existing rural water system for supply of domestic water. Inspect and use the existing water pressure regulator, backflow preventer, and 6000 gallon underground fiberglass holding tank.
 - Replace the domestic water pressure booster system
 - Replace water closets and urinals with vitreous china, wall hung water closets and wall hung urinals.
 - Replace water closet and urinal flush valves with electronic type, hard wired units.
 - Replace wall hung lavatory sinks with a multiple user lavatory station with composite solid surface construction and sensor type water outlets.
 - Replace electric water heater.
 - Replace domestic water piping insulation.
 - Provide bottle filler and piping.
- Mechanical System
 - Provide the following improvements to comply with Building Codes:
 - Remove electric radiant panels in the lobby and toilet rooms. Remove the residential type window air conditioning units in the lobby and toilet rooms.
 - Provide (2) electric air-to-air heat pump systems for heating, cooling and ventilation of the lobby and toilet rooms. Include supply and return ducts, registers, grilles, outside air intake louvers, electric heating coils in the outside / return air ducts, and temperature controls. Replace electric unit heaters in the two storage / equipment rooms.
 - Provide new electric radiant panels in the lobby near the large areas of glass. Provide electric unit heaters at each outside door to the lobby area.
 - Replace the (2) exhaust fans that serve the toilet rooms. Replace the exhaust grilles in each toilet room.
- Electrical System
 - Replace outdated building interior lighting with new. This can be prolonged by 3-5 years if needed. 100% replacement required.
 - Replace two circuit breaker panels located the main floor equipment room. Existing wiring in conduit may remain.
 - Replace existing electric hand dryers.
 - Replace existing CCTV system to provide remote monitoring of the facility.

Year 2025

Major improvements are not anticipated from year 2020 through year 2025. Annual maintenance allows facility to meet demand through the five year horizon.

Year 2030

- Site Systems
 - Provide additional concrete pavement panel replacement (10%).
 - Replace 20% of the sidewalks.
 - Replacement of all asphalt shoulders.

Year 2035

Major improvements are not anticipated from year 2030 through year 2035. Annual maintenance allows facility to meet demand through the five year horizon.

Year 2040

At this time the facility will have reached the service life limits for both the facility and the site infrastructure. The facility will also reaching capacity and will require an expansion as well as for parking. Given the extent of renovation projected, plus the costs of the addition, a new expanded 40 year replacement facility will be of better value at this time extending the useful life goal to 2080.

COST ESTIMATE

A conceptual level planning cost for the improvements was developed for each horizon year. These cost estimates account for the installation of horizon year improvements (as stated previously); annual maintenance costs, and also include an SDDOT inflation factor of 4.43 percent per year. A Project Expense Cost of 20% was also added to provide for factors such as design fees, and SDDOT project costs. **Table 5** summarizes the horizon year cost estimates.

Table 5. Horizon Year Cost Summary

Component	Five-Year Horizon Cost				
	Year 2020	Year 2025	Year 2030	Year 2035	Year 2040
Exterior	\$465,000	\$0	\$220,000	\$0	\$7,575,000
ADA (site &bldg.)	\$150,000	\$0	\$0	\$0	\$0
Building	\$305,000	\$0	\$0	\$0	\$2,160,000
Subtotal	\$920,000	\$0	\$220,000	\$0	\$9,735,000
Project Expenses	\$184,000	\$0	\$44,000	\$0	\$1,947,000
5yr Maintenance	\$351,000*	\$325,000	\$404,000	\$502,000	\$623,000
TOTAL	\$1,455,000	\$325,000	\$668,000	\$502,000	\$12,305,000

* 7 year Maintenance total

Through year 2020, the site costs primarily include lagoon relining, paving repairs and modifications for ADA, sidewalk repairs, replacement of irrigation system and new site lighting. Site repairs also include repairing of picnic shelters, tepee, and storage garage.

Building modifications include a complete renovation. With this investment the service life of the facility and site can be extended to year 2040.

By year 2030, the site will require some additional maintenance paving repairs to extend the service life of the site infrastructure to about 2040.

By Year 2040 the construction of a newer, larger replacement facility will be of better value to SDDOT than the renovation of the existing. Also the site as a whole will require a significant renovation.

CONCLUSION

In support of the Interstate Rest Areas Study, included is an analysis of the future needs at the Valley Springs Rest Area. The purpose of the analysis is to quantify future needs at the rest area for five year planning horizons starting in year 2020.

The Valley Springs Rest Area facilities as a whole, including the main building, site infrastructure, auto parking, and the lagoon system, are sufficiently sized to meet growth projections needs until 2040. (Note, reference the Valley Springs POE report for truck parking expansion requirements and budget).

The overall condition of the facility is poor. The facility at a minimum will need immediate ADA and building code improvements, and some key infrastructure improvements. Within five to ten years, a more complete interior and exterior renovation will be required. The site is in need of considerable investment including repairs to the lagoon system, new lighting and substantial accessibility modifications.

The restroom structure is one of the premier restroom facilities for SDDOT. It is small but sufficiently sized to accommodate long term growth projections. Given the extent of work immediately required, a general renovation is recommended as soon as possible. The project may possibly include a small family room and vestibule addition (which is not budgeted for). By providing a complete renovation, the service life of the facility will be extended to 2040, when the facility will be ready for replacement with a larger facility.

If you have any questions or need additional information regarding the conditions assessment feel free to contact Robert Morcom (MorcomRA@teamtsp.com) at TSP (605-343-6102).



April 28, 2014
REVISED July 25, 2014

MEMORANDUM

TO: Brad Remmich
SDDOT Transportation Planner

FROM: Timothy Roach, AIA
Jeremy Hahn, PE, PTOE

SUBJECT: SDDOT Interstate Rest Area Study
Technical Memorandum #4 – Valley Springs POE Needs Assessment
FHU Reference No. 113039-01

This Valley Springs POE Needs Memorandum provides a plan for preserving the existing facility through the Year 2040. However, SDDOT envisions a facility reconstruction at this location that would replace the dated POE in place now with an updated layout consistent with that of the recently rebuilt Sisseton POE. The memo includes an assessment of the ability of the current site to provide sufficient space for an upgraded POE facility.

In support of the Interstate Rest Areas Study, included is an analysis of the future needs at the Valley Springs POE Rest Area. The purpose of the analysis is to quantify future needs at the rest area for five year planning horizons starting in year 2020. The following sections detail future use estimates at the rest area, and the improvements necessary to meet anticipated demand.

FUTURE USE CALCULATIONS

Determining the future use at each facility is based on the methodology contained in *Technical Memorandum #3-Parking Conditions Summary*. The analysis procedure estimated the growth in truck traffic and developed long term parking estimates at each facility for the peak season. **Table 1** summarizes the growth in traffic estimated at the Valley Springs POE facility.

Table 1. Parking Growth Estimates

User Type	Existing Parked Vehicles/day	Seasonal Factor	Year 2040 Growth Factor	Year 2040 Parked Vehicles
Trucks (7 spaces)	49	1.14	2.2	123

*Estimated – includes added ADA needs.

Overall, the analysis indicates that daily users (truckers) will significantly increase by 2040 by an additional 150%. Peak hour truck parking projections are outlined in **Table 2**.

Table 2. Peak Period use – Truck Parking:

User Type	Existing Parked Vehicles – Peak hour use	Seasonal Factor	Year 2040 Growth Factor	Year 2040 parked Vehicles – Peak Period
Trucks (7 spaces)	4.3	1.14	2.2	11

At some point in the future, four new truck parking spaces will be required to extend the capacity of the facility to service growth needs of 11 spaces until 2040. This will not be required should the SDDOT elect to install an electronic metering system which will significantly reduce onsite traffic at the facility.

Occupant load calculations were developed using the previous parking projections.

The building code requires only one restroom for facilities with less than a design occupant load of 15 people or less (the design occupant load, for this facility is roughly 9). As we understand it the function of the restrooms is only to support the staff and not the truckers who use the adjacent Valley Springs Rest Area facility. An expansion is needed for this facility, which will require an additional restroom at a minimum. Also, note that sewage from the facility is serviced by the Valley Springs lagoon - the budget for repair and replacement work for this lagoon is included in the Valley Springs budget.

FACILITY NEEDS

Through the facility assessments, meetings with SDDOT maintenance staff and future use calculations, a list of facility needs was developed. The needs address numerous issues found during the facility assessments including ADA compliance, building code conformity and overall functionality. These improvements were phased in five year horizons, starting with year 2020.

Per the *Technical Review Report - Valley Springs Port of Entry*, and an initial and informal meeting with the SD Highway Patrol staff, the following key issues were identified:

1. An expansion is needed to the existing 800sf facility which is essential to meet current and long-term operational needs. *(A programming study to more accurately determine the future space requirements for the facility has not been developed, however there is a similar facility in Sisseton POE that we understand is similar to what would be needed (at 2400sf) to support long term growth requirements (assuming until 2040). This facility does not include an enclosed inspection area).*
2. An enclosed inspection station was requested for consideration however this has not been included in budgeting.
3. An Electronic Monitoring system is presently being considered for the facility by the SDDOT. Note the following:
 - a. It is not known at this time how the addition of this system, and the corresponding reduction of onsite truck traffic, will impact staffing and required square footage (either up or down) for the facility.
 - b. Budget costs for the system have not been included in this study.

April 28, 2014

REVISED July 25, 2014

Memorandum to Brad Remmich

Page 3

4. Concerning the site, per the SD Highway Patrol staff, no additional parking is required as staff increases look to remain stable and will not coincide with growth in trucking.
5. Concerning the truck parking the existing seven space lot will need to be expanded to account for projected growth to eleven spaces, unless an electronic pass system is implemented.

The following sections describe improvements to the facility in five year increments starting in year 2020 through year 2040:

Year 2020

The facility infrastructure has been so heavily used it is essentially ready for a total renovation, plus an addition. The following is a list of deficiencies that will need to be addressed to restore the facility to long- term viability:

- Code Improvements (IBC 2012):
 - Provide GFI power outlets, and additional power outlets.
 - Provide all new HVAC system and make up air.
 - Remove and replace storage areas not meeting 36" clearance near electrical panels.
 - Provide dual water cooler drinking fountain.
- Site required (ADA) Improvements
 - Assign accessible parking space (employee) with sign and pavement markings.
 - Upgrade/replace ramp and handrail system to current standards.
- Building (ADA) Improvements:
 - Replace main and rear entrance door closers and hardware or provide new door & hardware.
 - Provide ADA signage at employee restroom.
 - Provide ADA hardware on all doors and cabinetry.
 - Reset storage room door door swing out and provide sufficient ADA clearance on each side of the door.
 - Modify/provide new information counter per ADA Clearances and increase width at lobby access panel door.
 - Renovate toilet room:
 - Provide ADA compliant door and hardware.
 - Adjust toilet and sink locations to comply with clearances, and provide ADA compliant toilet, sink, faucet, and insulate pipes.
 - Replace water closet and urinals with vitreous china, wall hung water closets.
 - Replace water closet and urinal flush valves with electronic type, hard wired units
 - Provide and set accessories to ADA standards including handrails, mirror, and toilet paper holder.
 - Refinish room with new finishes.

April 28, 2014

REVISED July 25, 2014

Memorandum to Brad Remmich

Page 4

- Information counter needs to be rebuilt to accommodate an ADA user/guest with the required clearances, heights, and hardware.
- Remove utility room table to provide wheelchair clearance access to refrigerator.
- Site Systems
 - Provide lagoon system scheduled upgrades (see Valley Springs budget).
 - Repair deteriorating joint seals and spalling.
 - Remove and replace cracked and deteriorating concrete pavement panels (15% of panels).
 - Repair exterior concrete access walkway and stairs.
 - Replace 20% of the walkway.
 - Remove and replace approximately 65% of the asphalt pavement area.
 - Seal cracks and chip or slurry seal the remaining 35% of the asphalt pavement area.
 - Remove and replace ramp on east side of building. New ramp and railings shall meet ADA standards.
 - Asphalt crack sealing (approximately 25% of area) and seal coating.
 - Replace outdoor lighting with new energy efficient fixtures.
 - (Of note, truck scale equipment was not evaluated as part of this report.)
- Building System
 - Complete general exterior masonry minor repairs including tuck-pointing, clean and seal.
 - Provide gutters and downspouts.
 - Reroof and new gutters.
 - Repair and refinish eaves, trim, soffits.
 - Provide insulating glass replacement windows.
 - Provide general interior demolition and replacement of the interior including walls, ceilings, flooring, counters/cabinetry, and partitions.
- Plumbing System:
 - Use existing rural water system for supply of domestic water. Inspect and use the existing water pressure regulator, backflow preventer, and 6000 gallon underground fiberglass holding tank.
 - Replace the domestic water pressure booster system
 - Replace electric water heater.
 - Replace domestic water piping insulation.
 - Use the existing rural water system and pressure booster system from the adjacent rest area building for domestic water.
- Mechanical System
 - Replace non-functioning bathroom exhaust fan system (& make-up air).
 - Provide New HVAC System per building code including:
 - Replace the split-system air-to-air heat pump system.
 - Replace all air distribution ducts and locate them out of the attic space.
 - Provide adequate number of air supply diffusers in the main office area.
 - Provide an outside air intake louver and duct to the heat pump system.

April 28, 2014

REVISED July 25, 2014

Memorandum to Brad Remmich

Page 5

- Provide an electric duct heater in the outside air duct.
 - Provide a return air duct from the private office to the heat pump system.
 - Provide new supply and return air registers and grilles.
 - Remove ceiling mounted exhaust fans in the toilet room and equipment room. Replace exhaust fans with new exhaust systems.
 - Provide new temperature controls.
 - Provide ceiling mounted electric radiant panels near the windows.
- Electrical System
 - Replace outdated building interior lighting with new fixtures.
 - Replace circuit breaker panel located the main floor equipment room. Existing wiring in conduit may remain.
 - Replace existing CCTV system to provide remote monitoring of the facility.
 - Remove the existing emergency beacon system and replace with closed circuit alarm to a central monitoring station.

Year 2025

Major improvements are not anticipated from year 2020 through year 2025. Annual maintenance allows facility to meet demand through the five year horizon.

Year 2030:

- Site Systems
 - Provide additional concrete pavement panel replacement (10%).
 - Replacement of asphalt paving/shoulders (100%).

Year 2035

Major improvements are not anticipated from year 2030 through year 2035. Annual maintenance allows facility to meet demand through the five year horizon.

Year 2040

At this time the facility will have reached the service life limits for much of the site infrastructure and truck parking will likely require expansion again. Also, the replacement facility at this time will have aged about 20 years and will be ready for some interior and exterior systems updates and repairs.

COST ESTIMATE

A conceptual level planning cost for the improvements was developed for each horizon year. These costs estimates account for the installation of horizon year improvements (stated previously), annual maintenance costs and also include an SDDOT inflation factor of 4.43 percent per year. As the POE is a administrative facility, we have included a line item allowance for furniture, fixtures and equipment (FF&#). Also, a project expense cost of 20% was added to provide for factors such as design fees, and SDDOT project costs. **Table 3** summarizes the horizon year cost estimates.

Table 3. Horizon Year Cost Summary

Component	Five-Year Horizon Cost				
	Year 2020	Year 2025	Year 2030	Year 2035	Year 2040
Exterior	\$368,000	\$0	\$195,000	\$0	\$5,600,000
ADA (site & bldg.)	\$55,000	\$0	\$0	\$0	\$0
Building & FFE	\$877,000***	\$0	\$0	\$0	\$600,000
Subtotal	\$1,300,000	\$0	\$195,000	\$0	\$6,200,000
Project Expenses	\$260,000	\$0	\$39,000	\$0	\$ 1,240,000
5yr Maintenance	\$351,000*	\$325,000	\$404,000	\$502,000	\$ 623,000
TOTAL	\$1,911,000**	\$325,000	\$638,000	\$502,000	\$8,063,000

* 7 year Maintenance total

** Electronic Pass system have not been included, requiring additional study. Note that with this addition, deduct truck parking expansion costs including expenses \$135,000.

*** FF&E include allowance for updating scale system, and police radio system, along with furniture.

By 2020, Site costs primarily include the rebuilding of the existing entrance ramp system (ADA), and general paving repairs & joint replacement, new lighting, replacement of scale system and foundations, site expansion costs include new parking (4 stalls) and roadway extensions, additional lighting, building exterior repairs, windows, doors and reroof. Interior repairs consist of complete demolition and remodel including ADA repairs, code required HVAC system, power/lighting, new cabinetry, and all new finishes, etc. Building addition includes all furnishings and equipment with exception of communications equipment.

By year 2030, the site as a whole will require additional paving repairs to extend the service life of the site infrastructure to about 2040, and general building upgrades.

By Year 2040, the construction of a newer, larger replacement facility will be of better value to SDDOT then the renovation of the existing. Also the site as a whole will require a significant reinvestment, and will include some replacement lighting and expansion of parking (assume 4 spaces).

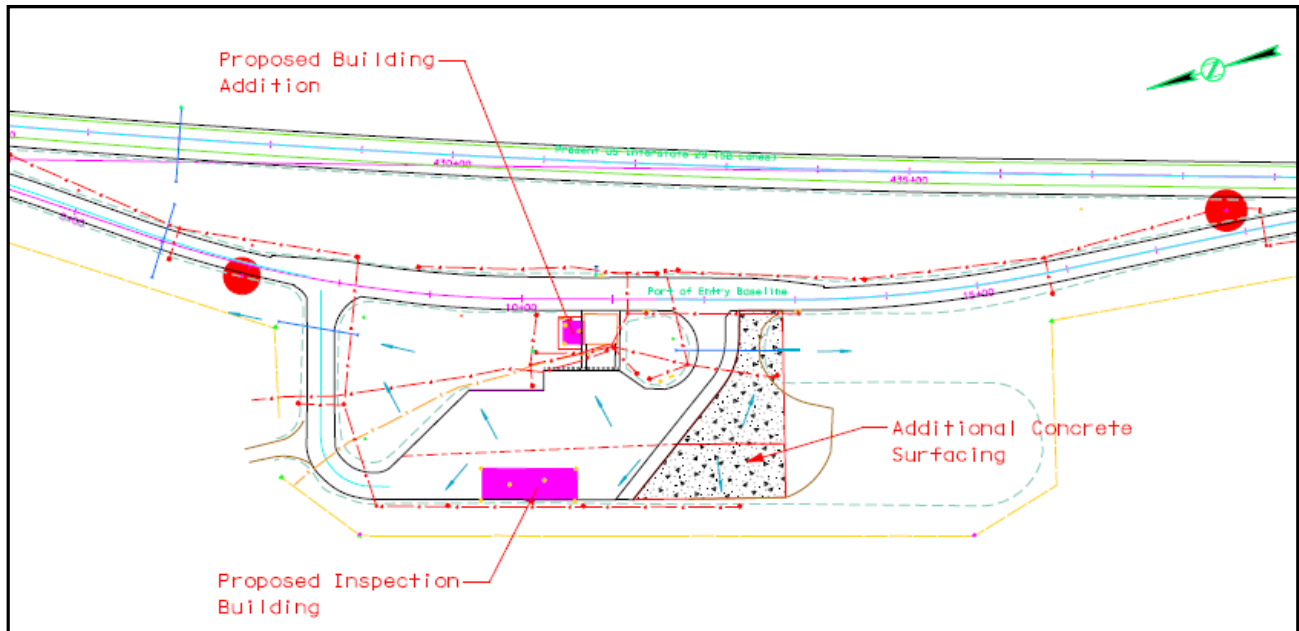
UPGRADED FACILITY ON CURRENT SITE

The SDDOT envisions a complete reconstruction of the POE that would replace the current facility with an updated layout consistent with that of the recently rebuilt Sisseton POE. Per SDDOT request, the project team assessed the ability of the current site to accommodate such an updated POE.

The Sisseton facility has been upgraded via a site expansion to provide the following elements:

- Expanded scale building, totaling approximately 1,400 Square Feet
- Heated inspection building, 3,500+ Square Feet
- Weigh-in-Motion (WIM) System

Below is a depiction of the Sisseton facility:



The project team reviewed the footprint of the Sisseton POE and found that it would require an approximate 200' wide x 550' long area to accommodate the layout. That 200' wide distance is from the north shoulder/ edge of the access road. On this basis, the existing Valley Springs area could accommodate an upgraded facility by routing the rest area access roadway slightly farther to the north and expanding west from the current POE facilities. A preliminary assessment of site grading to the west indicates that some fill might be required to sufficiently level the area.

Figure 1 depicts a potential layout for the updated/upgraded POE. The presence of the truck access roadway and inspection building would remove approximately 12 passenger car parking spaces from the Valley Springs Westbound rest area, but parking analyses indicate that the remaining spaces could accommodate projected Year 2040 demand, though peak parking lot occupancy could reach as high as 96 percent. The seven truck parking spaces within the existing POE area would remain and would be adequate to accommodate demand, assuming WIM technology is fully adopted at the site. It is recommended that the updated site continue to provide truck parking spaces, as particular situations such as weather emergencies can sometimes require that trucks stay parked at the POE for extended periods of time. The Sisseton POE staff noted in an informal telephone conversation that their newly expanded site has limited ability to accommodate such demand.

A repeated concern expressed by those familiar with the Valley Springs site is the driver confusion that results from serving both the POE and the general public rest area from the same I-90 exit ramp. This will remain a concern if the facility is upgraded at the current site. While this situation is not known to be causing any crashes, it is a significant issue for POE operations when a truck inadvertently enters the public rest area and requires rerouting.

Regarding the suitability of site infrastructure to accommodate an upgraded POE, further investigation is needed to determine whether the sanitary service will gravity flow to the lagoon or need to be pumped. A new inspection building would include a 4' deep inspection pit that has sump drain and might require a sump pump to remove liquid if it can't gravity flow to a holding tank.

While it is physically feasible to expand and update the POE on the current site, there are also a number of reasons to consider an alternative facility location.

ALTERNATIVE FACILITY LOCATION COSTS

As an option, relocation of the POE facility to a new off-site location was evaluated based on potential cost. With relocation of the POE facility, a new site will need to be purchased and developed. Newly constructed, site costs could be in the \$1,500,000 – \$2,500,000 cost range plus the cost of the land, and project development.

As the current site infrastructure is in good condition, with some maintenance costs and reinvestment, the useful life for the property could be extended until 2040 for very roughly a cost of \$350,000- \$400,000 (site costs) for current and long term repairs. This is a more cost effective approach and the savings over a new site provides significant budget room to make paving/circulation adjustments, and to provide improved highway ramp lighting and signage.

CONCLUSION

In support of the Interstate Rest Areas Study, included is an analysis of the future needs at the Valley Springs Port of Entry (POE). The purpose of the analysis is to quantify future needs at the rest area for five year planning horizons starting in year 2020.

The Valley Springs POE facility is heavily used and is ready for a complete renovation. Among the immediate needs include a few ADA and building code modifications, as well as a driving need for additional space. Approximately 1200sf is needed in addition to the 800sf existing, however it is important to note that a requested covered inspection area was not included in this assessment. Also not considered is the possible need for a temporary structure which may be needed to address operational needs until a new facility is provided.

The site is in good condition, although some immediate repairs are required to: extend the service life of the paving; for ADA improvements; and for additional truck parking spaces of 4 stalls to accommodate projected growth until 2040 (note: this added parking space may not be required should the SDDOT elect to install an electronic pass system).

This study has been based on the slightly less costly approach for the facility for a renovation and addition as opposed to a new replacement facility. The investment in an entirely new replacement facility may be more appropriate than renovating the existing. A new facility costs perhaps 10% more however it could be placed elsewhere on the property and would allow for the safe and uninterrupted operations of the existing facility while the new structure is being constructed. Another consideration not included in the budget is the development of an improved highway sign system and the provision of enhanced lighting to better guide truck drivers to the facility.

Constructing an updated, larger POE on the existing site appears to be physically feasible. However, on-site expansion plans would not address the current concern of shared access with the public rest area. Further evaluation is needed to make a decision regarding expansion.

If you have any questions or need additional information regarding the conditions assessment feel free to contact Bob Morcom, TSP, at (605)343-6102.

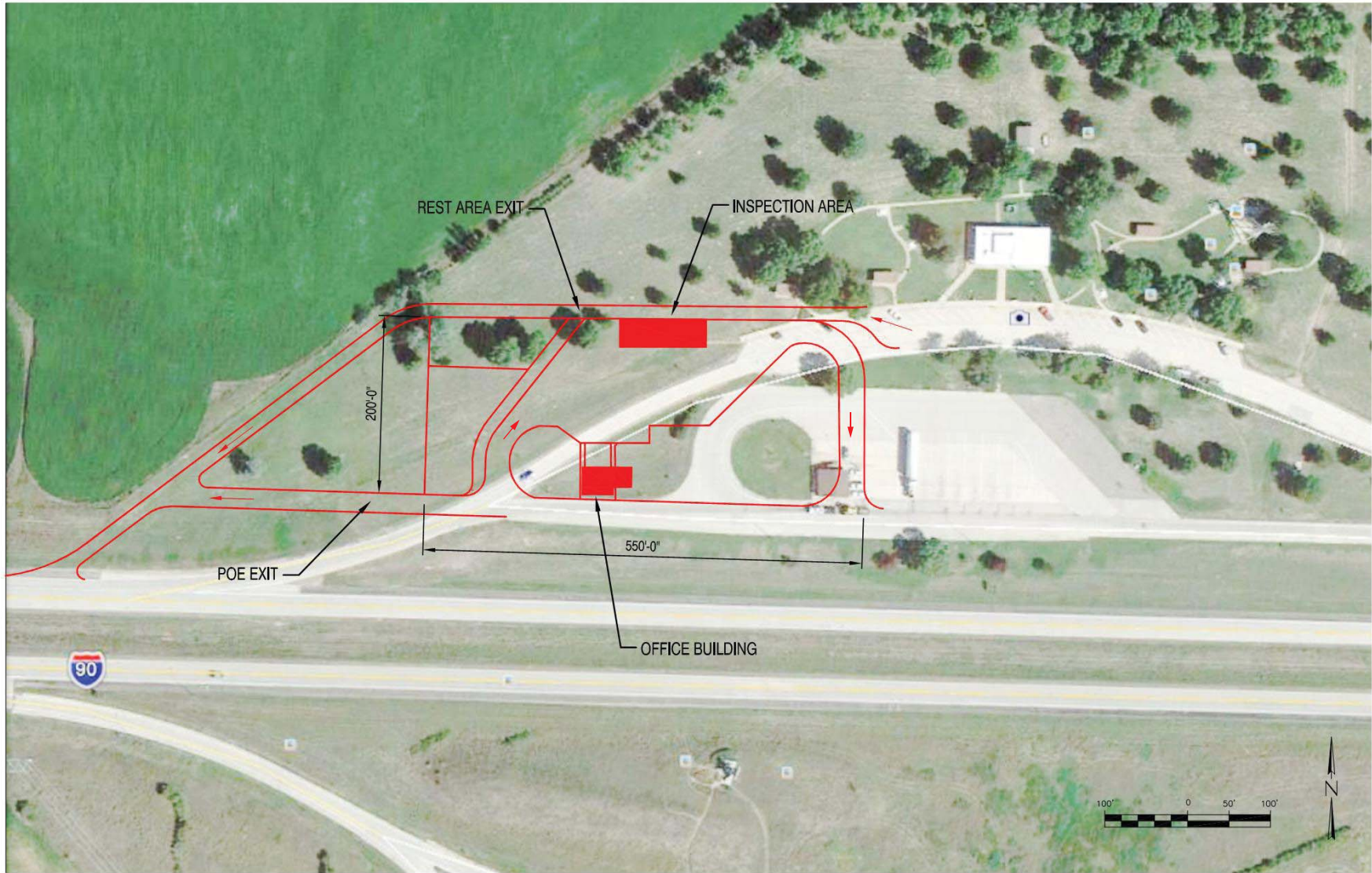


Figure 1. Valley Springs POE - Site Upgrade Layout





The Interstate Rest Areas Study: Along the I-29 and I-90 Corridors

April 28, 2014
REVISED July 19, 2014

MEMORANDUM

TO: Brad Remmich
SDDOT Transportation Planner

FROM: Timothy Roach, AIA
Jeremy Hahn, PE, PTOE

SUBJECT: SDDOT Interstate Rest Area Study
Technical Memorandum #4 – Homestead Needs Assessment
FHU Reference No. 113039-01

In support of the Interstate Rest Areas Study, included is an analysis of the future needs at the Homestead Rest Area. The purpose of the analysis is to quantify future needs at the rest area for five year planning horizons starting in year 2020. The following sections detail future use estimates at the rest area, and the improvements necessary to meet anticipated demand.

FUTURE USE CALCULATIONS

Determining the future use at each facility is based on the methodology contained in *Technical Memorandum #3-Parking Conditions Summary*. The analysis procedure estimated the growth in both passenger vehicles and truck traffic and developed long term parking estimates at each facility for the peak season. **Table 1** summarizes the growth in traffic estimated at the Homestead facility.

Table 1. Parking Growth Estimates

User Type	Existing Parked Vehicles	Seasonal Factor	Year 2040 Growth Factor	Year 2040 Parked Vehicles
Passenger Vehicles	104	1.12	1.45	169
Trucks	54	1.12	2.0	121

The parking growth estimates show that passenger vehicle parking is anticipated to increase at an average rate of 1.38% per year, while truck parking would increase at a 2.64% yearly growth rate. Overall, the analysis indicates that daily users will significantly increase, and that the shift to servicing truck drivers, who are predominantly male, could drive the need for enhancing the men’s restroom facilities.

Using the previous parking projections, occupant load calculations were developed. A key factor is determining the number of occupants in each vehicle. In the memorandum *1992 Safety Rest Area Usage Survey Reports*, 1992, Minnesota Department of Transportation, a user survey of motorists at the Marion Rest Area in Minnesota showed that an average of 2.3 persons per vehicle. For the

analysis, the 2.3 persons per vehicle occupancy rate has been applied only to passenger vehicles. In addition, it was assumed that the number of male and female occupants would be even.

Truck occupancy is anticipated to be far less, as most trucks have only a single driver. For purposes of this analysis, a 1.5 persons per vehicle occupancy rate was used for truck parking which accounts for tandem truck drivers and recreational vehicles. Currently, around 93% of truck drivers are male, but the number of female drivers is expected to increase in the future (<http://gobytrucknews.com/female-truckers-growing-in-number/>). To remain conservative, an 80/20 mix of male to female users was applied to the truck parking to account for an increase in female truck drivers and recreational vehicles which have a higher number of female passengers. **Table 2** provides a summary of the occupant load calculations at the rest area.

Table 2. Daily Occupant Load Summary

User	Existing Vehicles	Year 2040 Vehicles	Occupancy Factor	Existing Occupants	Year 2040 Occupants
Passenger Vehicles	116	169	2.3 per/veh	266 (M=133, F=133)	388 (M=194, F=194)
Trucks	60	121	1.5 per/veh	90 (M=72, F=18)	182 (M=145, F=37)
Totals				356 (M=205, F=151)	570 (M=339, F=231)

M=Male
 F=Female

Peak period use of the facilities was derived from hourly parking occupancy rates contained in the Parking Conditions memorandum. By analyzing the 24-hour parking occupancy percentages of both passenger vehicles and trucks in the Parking Conditions memorandum (see parking occupancy graphs - *Technical Memorandum #3 – Parking Conditions Summary*), the peak hour use of the facility can be determined for the existing year and the year 2040 horizons. **Table 3** summarizes the peak occupant loading of the facility.

Table 3. Peak Hour Occupant Load Summary

User	Existing Conditions	Year 2040 Conditions
Male	25	44
Female	16	24

The results show that occupant loads during a typical day are expected to increase significantly between now and year 2040 at the Homestead Rest Area. In addition, peak hourly use of the facility is also expected to grow fairly significantly between now and year 2040.

Using the occupant load estimates, an estimate on capacity of restrooms was developed. It was assumed that the design capacity of one toilet is eight persons per stall per hour. In addition, the existing rest area includes a total of four men’s and women’s toilets each, and it was assumed that in the future one toilet would be removed from the men’s rest room, and two from the women’s, to meet ADA requirements. Using the total number of toilets and peak hour occupant load estimates from **Table 3**, restroom capacity was developed for the two planning horizons. **Table 4** summarizes the capacity calculation.

Table 4. Restroom Capacity Calculation

User	Existing			Year 2040		
	Stalls	Peak Load	Capacity	Stalls	Peak Load	Capacity
Male	7	25	56	6	44	48
Female	6	16	48	4	24	32

The results show the rest area is currently functioning well under design capacity at roughly 50%-52% of total peak period capacity. In the future (2040), the men’s restroom will be nearing peak period capacity at 92% and the women’s restroom will be at about 74% of peak capacity.

Finally, the lagoon system serving the rest area was also reviewed. The lagoon was relined in 1998 and is planned to be serviced again in 2020. Also, according to current maintenance / use data, at peak season the lagoon operates well under capacity and should be sufficiently sized to accommodate growth projections until about 2030. At the time the rest area is expanded in the future, the lagoon system should be evaluated to determine if lagoon expansion is necessary to support future use estimates.

FACILITY NEEDS

Through the facility assessments, meetings with SDDOT maintenance staff and future use calculations, a list of facility needs was developed. The needs address numerous issues found during the facility assessments including ADA compliance, building code conformity and overall functionality. These improvements were phased in five year horizons, starting with year 2020.

Concerning the ADA requirements, both site and building improvements will be required to make the facility and the restrooms accessible to the public per ADA minimum standards. The two following options were developed to provide modifications to the interiors to create sufficient access routes into the restrooms and to create wheelchair accessible stalls:

:

- This can be achieved by offsetting and widening the existing interior vestibules to the restrooms, and by converting a pair of toilet stalls to a single larger accessible stall. This upgrade approach will result in the loss of one toilet stall and one sink each for the men’s and women’s restrooms. This is the selected approach taken for this report as the facility is currently operating significantly under capacity.
- As an option, to avoid the loss of capacity (stalls & sinks), a larger project would be required. The restrooms could be expanded by an addition to the front of the building to include the vestibule and possible space for family restrooms as well. Given the limited lobby space and space for general circulation, this expansion approach has more long-term usability potential.

The following sections describe improvements to the facility in five year increments starting in year 2020 through year 2040:

Year 2020

The facility was constructed in 1977 and is need of a significant renovation to provide ADA upgrades and to refurbish the aged infrastructure. As the facility has sufficient capacity, a complete renovation will be more feasible than ongoing maintenance repairs. With this renovation, it is believed that the service life of the facility can be extended to 2040. The following summarizes the 2020 horizon improvements:

- Code Improvements (IBC -2012):
 - Provide GFI power outlets and additional power outlets.
 - Remove and replace storage areas not meeting 36" clearance near electrical panels.
 - Provide standing drinking fountain to complement existing wheelchair accessible unit.
- Site required (ADA) Improvements
 - Provide accessible ramp replacement within maximum slope limitations of ADA between entrance and accessible parking spaces.
 - Provide curb ramps at accessible parking spaces.
 - Provide parking signs per MUTCD standards and a sign for the van accessible space.
 - Revise the parking striping so the van accessible space is 8' wide and the access aisle is 8' wide.
 - Modify an additional exterior picnic bench (recommended).
- Building (ADA) Improvements
 - Replace main entrance doors closer and hardware or provide entire new doors.
 - Provide new general interior signage to replace existing signs that meet current ADA standards.
 - Provide new phone with sound control, TTY plug in, and shelf.
 - Update/replace information counters.
 - Plan modifications for the restroom and restroom entries are required to provide for minimum interior clearances of the ADA. To achieve these requirements there are multiple options that could be considered by SDDOT to meet this and other needs. However, considering only the ADA, as the facility is currently operating well under capacity, TSP initially recommends the lower cost alternatives below which will be at the loss of 2 women's stalls and 1 men's, and possibly 35sf of the lobby area. The proposed modifications are as follows:
 1. Per ADA, *where doors are provided, wider aisle widths are required (52"-58)*. Restroom entry doorways are too narrow at 36" and need to be widened with new partitions, doors, and hardware. *(As a temporary option, prior to construction, the actual doors could be removed to meet the ADA, which then only requires a minimum 36" corridor width (however there are ventilation,*

privacy, and line of sight concerns). It is possible that the men's vestibule will need to be built into the lobby (7'x5' roughly).

2. Each restroom will require the addition of 5' accessible stalls. To do so can simply be achieved by removing one stall and enlarging an existing one. The new stalls will need to be properly modified with new partitions, handrails, properly placed accessories, and self-closing doors. Also, HC toilet locations should be adjusted to be between 16" & 18" on center from the side partition.

- Site Systems

- Re-open dump station by providing the lid modifications at station to reduce use for garbage.
- Provide lagoon system scheduled upgrades.
- Restripe of truck parking.
- Replace the lawn irrigation system and all of its components including the water pressure booster system.
- Rebuild exit ramp with reduced slope.
- Repair deteriorating joint seals in parking.
- Repair pavement spalling (5% of panels)
- Repair 20% of sidewalks including area surrounding the teepee.
- Replace outdoor ramp/highway, parking, building and pedestrian lighting with new energy efficient fixtures within five years.
- Inspect and repair existing picnic shelters; provide repairs and refinishing of decking and trim, and masonry tuck-pointing, sealing and repairs as required. Renovate (detached) Garage: repaint, provide replacement roofing, and replace existing doors and hardware.
- Inspect teepee structure; provide repairs as needed.
- Update landscaping.

- Building System

- Provide complete renovation of main facility including:
 - General exterior wall repairs (stone), tuck-pointing, clean and seal.
 - Install gutters and downspouts.
 - Clean, inspect and repair small copper roofs and gutters/downspouts at entry and rear.
 - Repair, caulk and repaint exterior eaves and soffits.
 - Replace storefront window systems (front and back)
 - General replacement of wall and floor tile, and ceiling repairs and paint.
 - Modify or provide new counter systems at information area.
 - Replace rear service doors and hardware.
 - Replace roof to match original.
- Provide small addition for entrance vestibule, family restroom, men's restroom vestibule.

- Plumbing System

- Renovate plumbing, piping and fixtures:
- Replace water closets and urinals with vitreous china, wall hung water closets and wall hung urinals.

- Replace wall hung lavatory sinks with a multiple user lavatory station with composite solid surface construction and sensor type water outlets.
 - Replace sink and toilet faucets and hardware.
 - Replace mop sink.
 - Replace water closet and urinal flush valves with electronic type, hard wired units within 5 years.
 - Modify existing supply, waste and vent piping as needed for new fixtures.
 - Use the existing waste, vent and domestic water distribution system, providing modification or repair as needed.
 - Replace domestic water piping insulation.
 - Replace the domestic water pressure booster system.
- Mechanical System
 - Replace (2) split-system air-to-air heat pump systems. Air distribution ducts may be reused.
 - Supply and return air registers to be replaced.
 - Replace electric unit heaters in the equipment / storage rooms. Outside air duct connections to both systems for ventilation to remain.
 - Replace the (2) exhaust fans that serve the toilet rooms. Replace the exhaust grilles in each toilet room. Replace the exhaust fan that serves the basement equipment room.
 - Electrical System
 - Replace outdated building interior lighting with new (100%).
 - Replace two circuit breaker panels located the main floor equipment room. Existing wiring in conduit may remain.
 - Replace existing electric hand dryers.
 - Replace existing CCTV system with new equipment that will allow remote monitoring of the facility.
 - Remove the existing emergency beacon system and replace with closed circuit alarm to a central monitoring station.
 - Possible enhancements to internet services installed in the building

Year 2025

Major improvements are not anticipated from year 2020 through year 2025. Annual maintenance allows facility to meet demand through the five year horizon.

Year 2030

- Site Systems
 - Provide additional concrete pavement panel replacement (10% Long-term).
 - Replace additional 20% walkway.

Year 2035

Major improvements are not anticipated from year 2035 through year 2040. Annual maintenance allows facility to meet demand through the five year horizon.

Year 2040

By 2040 the site and facility as a whole will have reached age and capacity limitations. Given the extent of renovation projected, plus the costs of a needed addition to support another generation of growth, a new expanded 40 year replacement facility will be of better value at this time extending the useful life goal to 2080. The site infrastructure will need to be expanded and completely overhauled as well (i.e., paving, lighting, landscape, shelters, garage, etc...) to also extend service life to 2080.

COST ESTIMATE

A conceptual level planning cost for the improvements was developed for each horizon year. These costs estimates account for the installation of horizon year improvements (as stated previously), annual maintenance costs, and also include an SDDOT inflation factor of 4.43 percent per year. A Project Expense Cost of 20% was also added to provide for factors such as design fees, and SDDOT project costs. **Table 5** summarizes the horizon year cost estimates.

Table 5. Horizon Year Cost Summary

Component	Five-Year Horizon Cost				
	Year 2020	Year 2025	Year 2030	Year 2035	Year 2040
Exterior	\$469,000	\$0	\$135,000	\$0	\$7,575,000
ADA (building & site)	\$105,000	\$0	\$0	\$0	\$0
Building	\$353,000	\$0	\$0	\$0	\$2,160,000
Subtotal	\$927,000	\$0	\$135,000	\$0	\$9,735,000
Project Expenses	\$185,000	\$0	\$27,000	\$0	\$1,947,000
5yr Maintenance	\$403,000*	\$335,000	\$370,000	\$410,000	\$ 450,000
TOTAL	\$1,515,000	\$335,000	\$532,000	\$410,000	\$12,132,000

* 7 year Maintenance total

Through year 2020, a major renovation of the facility as a whole is required. The renovation will include an overhaul of interior systems and finishes, and building shell improvements. With the needed improvements completed, the useful life of the facility would be extended to year 2040 when a larger replacement facility will be needed. The site costs primarily include lagoon system relining, replacement lighting, paving repairs, sidewalk repairs, replacement of irrigation system, and ADA associated repairs. On site structures including picnic shelters and storage garage will need some repair work as well.

By year 2030, the site as a whole will require additional paving repairs to extend the service life to about 2040.

By Year 2040, the construction of a newer, larger replacement facility will be of better value to SDDOT than the renovation of the existing. Also the site as a whole will require a significant reinvestment. Site work will include the general replacement of most aspects of the site

infrastructure including utilities, paving, lighting, shelters, as well as site amenities (i.e., landscaping, irrigation, signage, etc.).

CONCLUSION

In support of the Interstate Rest Areas Study, included is an analysis of the future needs at the Homestead Rest Area. The purpose of the analysis is to quantify future needs at the rest area for five year planning horizons starting in year 2020.

The Homestead Rest Area facilities as a whole, including the main building, site infrastructure, auto and truck parking, and the lagoon system, are sufficiently sized to meet growth projections until 2040.

The overall condition of the Homestead Rest Area is approaching “poor” as the facility has mostly original components and will need a major renovation within a few years, including major ADA improvements (as soon as possible). *(Although, the facility conceivably could be partially renovated soon, to gain a few more years’ service life, not long after this the facility will again be in need of a more comprehensive renovation project).* The site is in good condition, but will require considerable repairs to extend the service life to 2040.

In summary, the restroom structure, which is one of the larger restroom facilities for SDDOT, is sufficiently sized to accommodate long term growth projections. However, given age of the facility and the extent of work immediately required, a general renovation is recommended as soon as possible. By providing a complete renovation and possible addition (for family room & vestibule), the service life of the facility will be extended to 2040, when the facility will be ready for replacement with a larger facility. A slightly more costly alternative to this approach would be to simply build in 2020 a new larger facility sized for about 40 years growth (including lagoon). Also, note with this alternate approach some budgeting should also be provided for normal repairs and improvements in 2040.

If you have any questions or need additional information regarding the parking conditions assessment feel free to contact Bob Morcom (MorcomRA@teamtsp.com) at TSP (605-343-6102).



April 28, 2014
REVISED July 19, 2014

MEMORANDUM

TO: Brad Remmich
SDDOT Transportation Planner

FROM: Timothy Roach, AIA
Jeremy Hahn, PE, PTOE

SUBJECT: SDDOT Interstate Rest Area Study
Technical Memorandum #4 – Hidewood Northbound Needs Assessment
FHU Reference No. 113039-01

In support of the Interstate Rest Areas Study, included is an analysis of the future needs at the Hidewood Northbound Rest Area. The purpose of the analysis is to quantify future needs at the rest area for five year planning horizons starting in year 2020. The following sections detail future use estimates at the rest area, and the improvements necessary to meet anticipated demand.

FUTURE USE CALCULATIONS

Determining the future use at each facility is based on the methodology contained in *Technical Memorandum #3-Parking Conditions Summary*. The analysis procedure estimated the growth in both passenger vehicles and truck traffic and developed long term parking estimates at each facility for the peak season. **Table 1** summarizes the growth in traffic estimated at the Hidewood Northbound facility.

Table 1. Parking Growth Estimates

User Type	Existing Parked Vehicles	Seasonal Factor	Year 2040 Growth Factor	Year 2040 Parked Vehicles
Passenger Vehicles	199	1.1	1.42	311
Trucks	83	1.1	2.80	256

The parking growth estimates show that passenger vehicle parking is anticipated to increase at an average rate of 1.3% per year, while truck parking would increase at a 3.9% yearly growth rate. Overall, the analysis indicates that daily users will significantly increase, and that the shift to servicing truck drivers, who are predominantly male, could drive the need for enhancing the men’s restroom facilities.

Using the previous parking projections, occupant load calculations were developed. A key factor is determining the number of occupants in each vehicle. In the *1992 Safety Rest Area Usage Survey Reports*, by the Minnesota Department of Transportation, a user survey of motorists at the Marion Rest Area in Minnesota identified an average of 2.3 persons per vehicle. For the analysis, the 2.3

persons per vehicle occupancy rate has been applied only to passenger vehicles. In addition, it was assumed that the number of male and female occupants would be even. Truck occupancy is anticipated to be far less, as most trucks have only a single driver. For purposes of this analysis, a 1.5 persons per vehicle occupancy rate was used for truck parking which accounts for tandem truck drivers and recreational vehicles. Currently, around 93% of truck drivers are male, but the number of female drivers is expected to increase in the future (<http://gobytrucknews.com/female-truckers-growing-in-number/>). To remain conservative, an 80/20 mix of male to female users was applied to the truck parking to account for an increase in female truck drivers and recreational vehicles which have a higher number of female passengers. **Table 2** provides a summary of the occupant load calculations at the rest area.

Table 2. Daily Occupant Load Summary

User	Existing Vehicles (Peak)	Year 2040 Vehicles	Occupancy Factor	Existing Occupants	Year 2040 Occupants
Passenger Vehicles	219	311	2.3 per/veh	504 (M=252, F=252)	715 (M=357, F=356)
Trucks	91	256	1.5 per/veh	136 (M=109, F=27)	384 (M=307, F=77)
Totals				640 (M=361, F=279)	1,099 (M=664, F=433)

M=Male
 F=Female

Peak period use of the facilities was derived from hourly parking occupancy rates contained in the Parking Conditions memorandum. By analyzing the 24-hour parking occupancy percentages of both passenger vehicles and trucks in the Parking Conditions memorandum (see parking occupancy graphs: *Technical Memorandum #3 – Parking Conditions Summary*), the peak hour use of the facility can be determined for the existing year and the year 2040 horizons. **Table 3** summarizes the peak occupant loading of the facility.

Table 3. Peak Hour Occupant Load Summary

User	Existing Conditions	Year 2040 Conditions
Male	15	35
Female	8	15

The results show that occupant loads during a typical day are expected to double between now and the year 2040 at the Hidewood Northbound Rest Area. In addition, peak hourly use of the facility is also expected to nearly double between now and year 2040.

Using the occupant load estimates, an estimate on capacity of restrooms was developed. It was assumed that the design capacity of one toilet is eight persons per stall per hour. In addition, the existing rest area includes a total of four men’s and women’s toilets each, and it was assumed that in the future one toilet would be removed from each rest room to meet ADA requirements. Using the total number of toilets and peak hour occupant load estimates from **Table 3**, restroom capacity was developed for the two planning horizons. **Table 4** summarizes the capacity calculation.

Table 4. Restroom Capacity Calculation

User	Existing			Year 2040		
	Stalls	Peak Load	Capacity	Stalls	Peak Load	Capacity
Male	4	15	32	3	35	24
Female	4	8	32	3	15	24

The results show the rest area is currently functioning well under design capacity at roughly 34% (female) to 64%(male) of total peak period capacity (with three stalls each). In the future, the men’s restroom will exceed peak period capacity by approximately 2030, and the women’s will be sufficient beyond 2040.

Finally, the lagoon system serving the rest area was also reviewed. The lagoon was relined in 2011 and it is anticipated that the next improvements will be needed near 2030. Also, according to current maintenance / use data, at peak season the lagoon operates well under capacity and should be sufficiently sized to accommodate the projected increase in users until 2030. At the time the rest area is expanded in the future, the lagoon system should be evaluated to determine if lagoon expansion is necessary to support future use estimates.

FACILITY NEEDS

Through the facility assessments, meetings with SDDOT maintenance staff, and future use calculations, a list of facility needs was developed. The needs address numerous issues found during the facility assessments including ADA compliance, building code conformity and overall functionality. These improvements were phased in five year horizons, starting with the five year period ending in 2020.

Concerning the ADA requirements, both site and building improvements will be required to make the facility and the restrooms accessible to the public per ADA minimum standards. The two following options were developed to provide modifications to the interiors to create sufficient access routes into the restrooms and to create wheelchair accessible stalls:

- This can be achieved by offsetting and widening the existing interior vestibules to the restrooms, and by converting a pair of toilet stalls to a single larger accessible stall. This upgrade approach will likely result in the loss of one toilet stall and one sink each for the men’s and women’s restrooms. This is the selected approach taken for this report as the facility is currently operating significantly under capacity.
- As an option to avoid the loss of capacity (stalls & sinks), a larger project would be required. The restrooms can either be expanded into the lobbies, or widened by either an internal expansion into the maintenance shop, or by an addition on both sides of the facility. As the restrooms are already very narrow with limited access aisles, this expansion approach has more long-term usability potential.

The following sections describe improvements to the facility in five year increments starting in year 2020 through year 2040:

Year 2020

The facility was constructed in 1980, renovated in 1992, and requires additional improvements to meet ADA standards and to refurbish components of the aging infrastructure. With this renovation, it is anticipated that the service life of the facility can be extended to 2030. The following summarizes the 2020 horizon improvements:

- Code Improvements (IBC 2012)
 - Provide GFI power outlets, and additional power outlets.
- Site required (ADA) Improvements
 - Provide parking signs, including one van accessible parking sign, and striping.
 - Modify additional picnic bench for ADA (recommended, not required).
- Building (ADA) Improvements
 - Replace main entrance door closer and hardware or provide entire new door.
 - Provide new general signage to replace existing signs with new compliment with current ADA standards.
 - Provide new phone unit with sound control, TTY plug in, and shelf.
 - Reset soap dispensers above the lavatory counter. Set to a maximum height of 44 inches above the floor.
 - Plan modifications for the restroom and restroom entries are required to provide for minimum interior clearances of the ADA. To achieve these requirements there are multiple options that could be considered by SDDOT. However, considering only the ADA, as the facility is currently operating well under capacity, the lower cost alternatives below are recommended (note this approach will be at the loss of 2 sinks and 2 stalls). The proposed modifications are as follows:
 1. *Per ADA, where doors are provided wider aisle widths are required (52"-58). Restroom entry doorways are too narrow at 36" and need to be widened with new partitions, doors, and hardware. (As a temporary option, prior to construction, the actual doors could be removed to meet the ADA, which then only requires a minimum 36" corridor width - however there are ventilation, privacy, and line of sight concerns). This approach will require modifications to the existing bearing walls and possibly roof framing.*
 2. Each restroom will require the addition of 5' accessible stalls. This can be simply achieved by removing one stall and enlarging an existing one. The new stalls will need to be properly modified with new partitions, handrails, properly placed accessories, and self-closing doors. Also, HC toilet locations should be adjusted to be between 16" & 18" on center from the side partition.

- Parking
 - Expand the truck parking lot from the existing 8 spaces to 24 total parking spaces.
- Site Systems
 - Replace failed shingle roofing on the picnic shelters, and repair picnic shelter structures as required.
 - Replace the lawn irrigation system.
 - Re-grade around roof drains to create proper site drainage of runoff.
 - Repair deteriorating joint seals and spalling, and 5% of the panels.
 - Repair 15% of the sidewalks.
 - Replace outdoor lighting including parking, building, and pedestrian systems with new energy efficient fixtures. Replace recessed and surface mounted fixtures on the building.
- Building System
 - Replace shingle roofing on main building with possible repairs to deck, trim, and gutter replacement. Clean, seal and inspect existing metal roof at entrance.
- Plumbing System
 - Replace water closet and urinal flush valves with electronic type, hard wired units.
- Mechanical System
 - Replace both split-system gas fired furnaces with high efficiency units.
- Electrical System
 - Replace all building interior lighting.
 - Replace existing electric hand dryers.
 - Inspect and update power system where needed.

Year 2025

Major improvements are not anticipated from year 2020 through year 2025. Annual maintenance allows facility to meet demand through the five year horizon.

Year 2030

The site infrastructure is aging but is in good condition in general; however some maintenance upgrades at this time will be needed to extend the service live of the facilities. (In 2040 a complete overhaul will be required).

- Site Systems
 - Replace additional paving panels (10%)
 - Replace additional 20% sidewalks
 - Relining of sewage lagoon and possible expansion.

- Renovate existing picnic shelters; provide refinishing of materials, and masonry cleaning and repairs.

With respect to the building, at this time a major renovation and expansion of the facility will be needed at a minimum; however a total replacement facility will be of better value. (The cost for a total renovation alone will roughly will be about 2/3rds the cost, or more, of a new replacement facility of the same size. In addition to the renovation work, an expansion of the facility will be needed to address growth projections in the Men’s restroom area (to 2040), plus possibly to provide for added family restroom). Under this scenario, a new expanded 40 year replacement facility will be of better value at this time extending the useful life goal to 2070.

Year 2035

Major improvements are not anticipated from year 2030 through year 2035. Annual maintenance allows facility to meet demand through the five year horizon.

Year 2040

Major improvements are not anticipated for the building from year 2035 through year 2040. Annual maintenance allows facility to meet demand through the five year horizon. However, a major overhaul of the site infrastructure will be required.

COST ESTIMATE

A conceptual level planning cost for the improvements was developed for each horizon year. These costs estimates account for the installation of horizon year improvements (as stated previously), annual maintenance costs, and also include an SDDOT inflation factor of 4.43 percent per year. A Project Expense Cost of 20% was also added to provide for factors such as design fees, and SDDOT project costs. **Table 5** summarizes the horizon year cost estimates.

Table 5. Horizon Year Cost Summary

Component	Five-Year Horizon Cost				
	Year 2020	Year 2025	Year 2030	Year 2035	Year 2040
Exterior	\$447,000	\$0	\$406,000	\$0	\$7,575,000
ADA (site & facility)	\$76,000	\$0	\$0	\$0	\$0
Building	\$165,000	\$0	\$1,400,000	\$0	\$0
Subtotal	\$688,000	\$0	\$1,806,000	\$0	\$7,575,000
Project Expenses	\$138,000	\$0	\$ 361,000	\$0	\$1,515,000
5yr Maintenance	\$372,000*	\$345,000	\$428,000	\$531,000	\$ 660,000
TOTAL	\$1,198,000	\$345,000	\$2,595,000	\$531,000	\$9,750,000

* 7 year Maintenance total

Through year 2020, site costs primarily include paving expansion for truck parking, and general repairs to paving and sidewalks, and the replacement of lighting and irrigation systems. Site infrastructure repairs include a need for reroofing and repairing of picnic shelters. Building modifications primarily include significant ADA improvements, roof replacement, furnace replacement and plumbing improvements, interior upgrades, and complete replacement of lighting. With these improvements, the useful life of the facility will be extended to year 2030, or possibly further, depending upon when the changes are made.

By year 2030, the construction of a newer, larger replacement facility will be of better value to SDDOT than the renovation of the existing. Also the site as a whole will require repairs and the relining of the lagoon (and possible expansion). The site improvements would extend the service life of the infrastructure to about 2040.

By Year 2040, investment to the facility will be minimum however, the site infrastructure including utilities, paving, lighting, will require general replacement, as well as site amenities (i.e., landscaping, irrigation, picnic shelters/tables, etc.)

CONCLUSION

In support of the Interstate Rest Areas Study, included is an analysis of the future needs at the Hidewood Northbound Rest Area. The purpose of the analysis is to quantify future needs at the rest area for five year planning horizons starting in year 2020.

The condition of the facility as compared to other rest areas studied (which are older) is fair; however there is a need for ADA modifications and some infrastructure repairs soon. The site infrastructure condition is in good condition however there will need to be a considerable investment to allow for repairs and parking expansion.

The capacity of the Hidewood Northbound Rest Area facility including the site infrastructure and the lagoon system are sufficient to meet growth requirements until 2030, except for truck parking. The truck parking area is currently near peak design capacity and will need to be expanded from 8 spaces to 24 to support growth projections until 2040. By 2030, the men's restroom will have reached capacity limits, and will need to be expanded (as well as the lagoon). The women's restroom has sufficient capacity to support projected traveler increases until beyond 2040.

In summary, we have initially provided for facility and site renovation work sufficient enough to extend the service life of the facility to 2030 when at that time the facility as a whole will be approaching the end of its service life, and will have begun to exceed capacity limitations. At this time, the facility will be ready for an expansion and a complete renovation, and given the scale of work, it will be as or more feasible to provide a new expanded 40 year facility. At this same time (2030), it is also recommended to provide another 10 year upgrade of the existing site infrastructure until a full replacement of paving and site amenities will be required in the future (2040).

If you have any questions or need additional information regarding the conditions assessment feel free to contact Robert Morcom (morcomRA@teamtsp.com) at TSP (605-343-6102).



The Interstate Rest Areas Study: Along the I-29 and I-90 Corridors

April 28, 2014
REVISED July 19, 2014

MEMORANDUM

TO: Brad Remmich
SDDOT Transportation Planner

FROM: Timothy Roach, AIA
Jeremy Hahn, PE, PTOE

SUBJECT: SDDOT Interstate Rest Area Study
Technical Memorandum #4 – Hidewood Southbound Needs Assessment
FHU Reference No. 113039-01

In support of the Interstate Rest Areas Study, included is an analysis of the future needs at the Hidewood Southbound Rest Area. The purpose of the analysis is to quantify future needs at the rest area for five year planning horizons starting in year 2020. The following sections detail future use estimates at the rest area, and the improvements necessary to meet anticipated demand.

FUTURE USE CALCULATIONS

Determining the future use at each facility is based on the methodology contained in *Technical Memorandum #3-Parking Conditions Summary*. The analysis procedure estimated the growth in both passenger vehicles and truck traffic and developed long term parking estimates at each facility for the peak season. **Table 1** summarizes the growth in traffic estimated at the Hidewood Southbound facility.

Table 1. Parking Growth Estimates

User Type	Existing Parked Vehicles	Seasonal Factor	Year 2040 Growth Factor	Year 2040 Parked Vehicles
Passenger Vehicles	170	1.1	1.42	266
Trucks	93	1.1	2.80	286

The parking growth estimates show that passenger vehicle parking is anticipated to increase at an average rate of 1.3% per year, while truck parking would increase at a 3.9% yearly growth rate. Overall, the analysis indicates that daily users will significantly increase, and that the shift to servicing truck drivers, who are predominantly male, could drive the need for enhancing the men's restroom facilities.

Using the previous parking projections, occupant load calculations were developed. A key factor is determining the number of occupants in each vehicle. In the memorandum *1992 Safety Rest Area Usage Survey Reports*, 1992, Minnesota Department of Transportation, a user survey of motorists at the Marion Rest Area in Minnesota identified an average of 2.3 persons per vehicle. For the

analysis, the 2.3 persons per vehicle occupancy rate has been applied only to passenger vehicles. In addition, it was assumed that the number of male and female occupants would be even.

Truck occupancy is anticipated to be far less, as most trucks have only a single driver. For purposes of this analysis, a 1.5 persons per vehicle occupancy rate was used for truck parking which accounts for tandem truck drivers and recreational vehicles. Currently, around 93% of truck drivers are male, but the number of female drivers is expected to increase in the future (<http://gobytrucknews.com/female-truckers-growing-in-number/>). To remain conservative, an 80/20 mix of male to female users was applied to the truck parking to account for an increase in female truck drivers and recreational vehicles which have a higher number of female passengers. **Table 2** provides a summary of the occupant load calculations at the rest area.

Table 2. Daily Occupant Load Summary

User	Existing Vehicles (peak)	Year 2040 Vehicles	Occupancy Factor	Existing Occupants	Year 2040 Occupants
Passenger Vehicles	187	266	2.3 per/veh	430 (M=215, F=215)	612 (M=306, F=306)
Trucks	102	286	1.5 per/veh	153 (M=122, F=31)	429 (M=343, F=86)
Totals				583 (M=337, F=246)	1,041 (M=649, F=392)

M=Male
 F=Female

Peak period use of the facilities was derived from hourly parking occupancy rates contained in the Parking Conditions memorandum. By analyzing the 24-hour parking occupancy percentages of both passenger vehicles and trucks in the Parking Conditions memorandum (see parking occupancy graphs: *Technical Memorandum #3 – Parking Conditions Summary*), the peak hour use of the facility can be determined for the existing and year 2040 horizons. **Table 3** summarizes the peak occupant loading of the facility.

Table 3. Peak Hour Occupant Load Summary

User	Existing Conditions	Year 2040 Conditions
Male	20	41
Female	13	21

The results show that occupant loads during a typical day are expected to double between now and year 2040 at the Hidewood Southbound Rest Area. In addition, peak hourly use of the facility is also expected to nearly double between now and year 2040.

Using the occupant load estimates, an estimate on capacity of restrooms was developed. It was assumed that the design capacity of one toilet is eight persons per stall per hour. In addition, the existing rest area includes four men’s and women’s toilets each, and it was assumed that in the future one toilet would be removed from each rest room to meet ADA requirements. Using the total number of toilets and peak hour occupant load estimates from **Table 3**, restroom capacity was developed for the two planning horizons. **Table 4** summarizes the capacity calculation.

Table 4. Restroom Capacity Calculation

User	Existing			Year 2040		
	Stalls	Peak Load	Capacity	Stalls	Peak Load	Capacity
Male	4	20	32	3	41	24
Female	4	13	32	3	21	24

The results show the rest area is currently functioning under design capacity at roughly 53% (female) to 82% (male) of total peak period capacity (with 3 stalls each). Assuming straight line growth, the men’s facility will have reached peak capacity by 2025. By 2040, the women’s facility would be operating near the capacity threshold.

Finally, the lagoon system serving the rest area was also reviewed. The lagoon was relined in 2011 and it is anticipated that the next improvements will be 2030. Also, according to current maintenance / use data, at peak season the lagoon operates well under capacity and should be sufficiently sized to accommodate the projected increase in users until 2030. At the time the rest area is expanded in the future, the lagoon system should be evaluated to determine if lagoon expansion is necessary to support future use estimates.

FACILITY NEEDS

Through the facility assessments, meetings with SDDOT maintenance staff and future use calculations, a list of facility needs was developed. The needs address numerous issues found during the facility assessments including ADA compliance, building code conformity and overall functionality. These improvements were phased in five year horizons, starting with the five year period ending in 2020.

Concerning the ADA requirements, both site and building improvements will be required to make the facility and the restrooms accessible to the public per ADA minimum standards. The two following options were developed to provide modifications to the interiors to create sufficient access routes into the restrooms and to create wheelchair accessible stalls:

- This can be achieved by offsetting and widening the existing interior vestibules to the restrooms, and by converting a pair of toilet stalls to a single larger accessible stall. This upgrade approach will likely result in the loss of one toilet stall and one sink each for the men’s and women’s restrooms. This is the selected approach taken for this report as the facility is currently operating significantly under capacity.
- As an option to avoid the loss of capacity (stalls & sinks), a larger project would be required. The restrooms can either be expanded into the lobbies, or widened by either an internal expansion into the maintenance shop, or by an addition on both sides of the facility. As the restrooms are already very narrow with limited access aisles, this expansion approach has more long-term usability potential.

The following sections describe improvements to the facility in five year increments starting in year 2020 through year 2040:

Year 2020

The facility was constructed in 1980, renovated in 1992, and requires additional improvements to address ADA needs and refurbish components of the aging infrastructure. With this renovation the service life of the facility can be extended to 2030. The following summarizes the 2020 horizon improvements:

- Code Improvements (IBC 2012):
 - Provide GFI power outlets, and additional power outlets.
- Site required (ADA) Improvements
 - Provide parking signs, including one van accessible parking sign, and striping.
 - Modify additional picnic bench for ADA compliance (recommended).
- Building (ADA) Improvements
 - Replace main entrance door closer and hardware or provide entire new door.
 - Provide new general signage to meet ADA standards.
 - Provide new unit with sound control, TTY plug in, and shelf.
 - Reset soap dispensers above the lavatory counter, to a maximum height of 44 inches above the floor.
 - Plan modifications for the restroom and restroom entries are required to provide for minimum interior clearances of the ADA. To achieve these requirements there are multiple options that could be considered by SDDOT. However, considering only the ADA, as the facility is currently operating well under capacity, the lower cost alternatives below are recommended (note this approach will be at the loss of 2 sinks and 2 stalls). The proposed modifications are as follows:
 1. *Per ADA, where doors are provided wider aisle widths are required (52"-58). Restroom entry doorways are too narrow at 36" and need to be widened with new partitions, doors, and hardware. (As a temporary option, prior to construction, the actual doors could be removed to meet the ADA, which then only requires a minimum 36" corridor width - however there are ventilation, privacy, and line of sight concerns).* This approach will require modifications to the existing bearing walls and possibly roof framing.
 2. Each restroom will require the addition of 5' accessible stalls. This can be simply achieved by removing one stall and enlarging an existing one. The new stalls will need to be properly modified with new partitions, handrails, properly placed accessories, and self-closing doors. Also, HC toilet locations should be adjusted to be between 16" & 18" on center from the side partition.

- Parking
 - Expand the truck parking lot from the existing 7 spaces to 19 total parking spaces.
- Site Systems
 - Replace failed shingle roofing on the picnic shelters, and repair picnic shelter structures as required.
 - Replace the lawn irrigation system.
 - Re-grade around roof drains to create proper site drainage of runoff.
 - Repair deteriorating joint seals and spalling, and 5% of the panels.
 - Repair 15% of the sidewalks.
 - Replace outdoor lighting including parking, building, and pedestrian systems with new energy efficient fixtures. Replace recessed and surface mounted fixtures on the building.
- Building System
 - Replace shingle roofing on main building with possible repairs to deck, trim, and gutter replacement. Clean, seal and inspect existing metal roof at entrance.
- Plumbing System
 - Replace water closet and urinal flush valves with electronic type, hard wired units.
- Mechanical System
 - Replace (2) split-system fired furnaces, with high efficiency units, and other equipment modifications as needed.
- Electrical System
 - Replace all building interior lighting.
 - Replace existing electric hand dryers.
 - Inspect and update power system where needed.

Year 2025

Major improvements are not anticipated from year 2020 through year 2025. Annual maintenance allows facility to meet demand through the five year horizon.

Year 2030

The site infrastructure is aging but is in good condition in general; however some maintenance upgrades at this time will be needed to extend the service live of the facilities. (In 2040 a complete overhaul will be required).

- Site Systems
 - Replace additional paving panels (10%)
 - Replace additional 20% sidewalks

- Relining of sewage lagoon and possible expansion.
- Renovate existing picnic shelters; provide refinishing of materials, and masonry cleaning and repairs.

With respect to the building, at this time a major renovation and expansion of the facility will be needed at a minimum; however a total replacement facility will be of better value. (The cost for a total renovation alone will roughly will be about 2/3rds the cost, or more, of a new replacement facility of the same size. In addition to the renovation work, an expansion of the facility will be needed to address growth projections in the Men’s restroom area (to 2040), plus possibly to provide for added family restroom). Under this scenario, a new expanded 40 year replacement facility will be of better value at this time extending the useful life goal to 2070.

Year 2035

Major improvements are not anticipated from year 2030 through year 2035. Annual maintenance allows facility to meet demand through the five year horizon.

Year 2040

Major improvements are not anticipated for the building from year 2035 through year 2040. Annual maintenance allows facility to meet demand through the five year horizon. However, a major overhaul of the site infrastructure will be required.

COST ESTIMATE

A conceptual level planning cost for the improvements was developed for each horizon year. These costs estimates account for the installation of horizon year improvements (as stated previously), annual maintenance costs, and also include an SDDOT inflation factor of 4.43 percent per year. A Project Expense Cost of 20% was also added to provide for factors such as design fees, and SDDOT project costs. **Table 5** summarizes the horizon year cost estimates.

Table 5. Horizon Year Cost Summary

Component	Five-Year Horizon Cost				
	Year 2020	Year 2025	Year 2030	Year 2035	Year 2040
Exterior	\$331,000	\$0	\$406,000	\$0	\$7,575,000
ADA (site & facility)	\$76,000	\$0	\$0	\$0	\$0
Building	\$163,000	\$0	\$1,400,000	\$0	\$0
Subtotal	\$570,000	\$0	\$1,806,000	\$0	\$7,575,000
Project Expenses	\$114,000	\$0	\$361,000	\$0	\$1,515,000
5yr Maintenance	\$372,000*	\$345,000	\$428,000	\$531,000	\$660,000
TOTAL	\$1,056,000	\$345,000	\$2,595,000	\$531,000	\$9,750,000

* 7 year Maintenance total

Through year 2020, site costs primarily include paving expansion for truck parking, and general repairs to paving and sidewalks, and the replacement of lighting and irrigation systems. Site structures effort includes a need for reroofing and repairing of picnic shelters. Building modifications primarily include significant ADA improvements, roof replacement, furnace replacement and plumbing improvements, interior upgrades, and complete replacement of lighting.

With these improvements, the useful life of the facility will be extended to year 2030, or possibly further, depending upon when the changes are made.

By year 2030, the construction of a newer, larger replacement building will be of better value to SDDOT than the renovation of the existing. Also the site as a whole will require repairs and the relining of the lagoon (and possible expansion). The site improvements would extend the service life of the infrastructure to about 2040.

By Year 2040, investment to the facility will be minimum however, the site infrastructure including utilities, paving, lighting, will require general replacement, as well as site amenities (i.e., landscaping, irrigation, picnic shelters/tables, etc.)

CONCLUSION

In support of the Interstate Rest Areas Study, included is an analysis of the future needs at the Hidewood Southbound Rest Area. The purpose of the analysis is to quantify future needs at the rest area for five year planning horizons starting in year 2020.

The condition of the facility as compared to other rest areas studied (which are older) is fair; however there is a need for ADA modifications and some infrastructure repairs soon. The site infrastructure condition is in good condition however there will need to be a considerable investment to allow for repairs and parking expansion.

The capacity of Hidewood Southbound Rest Area facility including the site infrastructure and the lagoon system are sufficient to meet growth requirements until 2030 except for truck parking. The truck parking area is currently at peak design capacity and will need to be expanded from 7 spaces to 19 to support growth projections until 2040. In 2025, the Men's restroom will have reached capacity limits, and will need to be expanded (as well as the lagoon). The women's restroom has sufficient capacity to support projected traveler increases until beyond 2040.

In summary, we have initially provided for facility and site renovation work sufficient enough to extend the service life of the facility to 2030 when at that time the facility as a whole will be approaching the end of its service life, and will have begun to exceed capacity limitations. At this time, the facility will be ready for an expansion and a complete renovation, and given the scale of work, it will be as or more feasible to provide a new expanded 40 year facility than renovating. At this same time (2030), it is also recommended to provide another 10 year upgrade of the existing site infrastructure until a full replacement of paving and site amenities will be required in the future (2040).

If you have any questions or need additional information regarding the conditions assessment feel free to contact Robert Morcom (MorcomRA@teamtsp.com) at TSP (605-343-6102).



The Interstate Rest Areas Study: Along the I-29 and I-90 Corridors

April 28, 2014
REVISED July 19, 2014

MEMORANDUM

TO: Brad Remmich
SDDOT Transportation Planner

FROM: Timothy Roach, AIA
Jeremy Hahn, PE, PTOE

SUBJECT: SDDOT Interstate Rest Area Study
Technical Memorandum #4 – Tilford East Needs Assessment
FHU Reference No. 113039-01

In support of the Interstate Rest Areas Study, included is an analysis of the future needs at the Tilford East Rest Area. The purpose of the analysis is to quantify future needs at the rest area for five year planning horizons starting in year 2020. The following sections detail future use estimates at the rest area, and the improvements necessary to meet anticipated demand.

FUTURE USE CALCULATIONS

Determining the future use at each facility is based on the methodology contained in *Technical Memorandum #3-Parking Conditions Summary*. The analysis procedure estimated the growth in both passenger vehicles and truck traffic and developed long term parking estimates at each facility for the peak season. **Table 1** summarizes the growth in traffic estimated at the Tilford East facility.

Table 1. Parking Growth Estimates

User Type	Existing Parked Vehicles	Seasonal Factor	Year 2040 Growth Factor	Year 2040 Parked Vehicles
Passenger Vehicles	80	1.6	1.27	163
Trucks	51	1.6	2.2	180

The parking growth estimates show that passenger vehicle parking is anticipated to increase at an average rate of 1.38% per year, while truck parking would increase at a 2.64% yearly growth rate. Overall, the analysis indicates that daily users will significantly increase, and that the shift to servicing truck drivers, who are predominantly male, could drive the need for enhancing the men’s restroom facilities.

Using the previous parking projections, occupant load calculations were developed. A key factor is determining the number of occupants in each vehicle. In the memorandum *1992 Safety Rest Area Usage Survey Reports*, 1992, Minnesota Department of Transportation, a user survey of motorists at the Marion Rest Area in Minnesota identified an average of 2.3 persons per vehicle. For the

analysis, the 2.3 persons per vehicle occupancy rate has been applied only to passenger vehicles. In addition, it was assumed that the number of male and female occupants would be even.

Truck occupancy is anticipated to be far less, as most trucks have only a single driver. For purposes of this analysis, 1.5 persons per vehicle occupancy rate was used for truck parking which accounts for tandem truck drivers and recreational vehicles. Currently, around 93% of truck drivers are male, but the number of female drivers is expected to increase in the future (<http://gobytrucknews.com/female-truckers-growing-in-number/>). To remain conservative, an 80/20 mix of male to female users was applied to the truck parking to account for an increase in female truck drivers and recreational vehicles which have a higher number of female passengers. **Table 2** provides a summary of the occupant load calculations at the rest area.

Table 2. Daily Occupant Load Summary

User	Existing Vehicles (@Peak)	Year 2040 Vehicles	Occupancy Factor	Existing Occupants	Year 2040 Occupants
Passenger Vehicles	128	163	2.3 per/veh	294 (M=147, F=147)	375 (M=188, F=187)
Trucks	82	180	1.5 per/veh	123 (M=98, F=25)	270 (M=216, F=54)
Totals				417 (M=245, F=172)	645 (M=404, F=241)

M=Male
 F=Female

Peak period use of the facilities was derived from hourly parking occupancy rates contained in the Parking Conditions memorandum. By analyzing the 24-hour parking occupancy percentages of both passenger vehicles and trucks in the Parking Conditions memorandum (see parking occupancy graphs: *Technical Memorandum #3 – Parking Conditions Summary*), the peak hour use of the facility can be determined for the existing and year 2040 horizons. **Table 3** summarizes the peak occupant loading of the facility.

Table 3. Peak Hour Occupant Load Summary

User	Existing Conditions	Year 2040 Conditions
Male	19	33
Female	11	17

The results show that occupant loads during a typical day are expected to roughly double between now and year 2040 at the Tilford East Rest Area. In addition, peak hourly use of the facility is also expected to increase significantly between now and year 2040.

Using the occupant load estimates, an estimate on capacity of restrooms was developed. It was assumed that the design capacity of one toilet is eight persons per stall per hour. In addition, the existing rest area provides a total of five men’s and women’s toilets each, and it was assumed that in the future one toilet would be removed from each rest room to meet ADA requirements. Using the total number of toilets and peak hour occupant load estimates from **Table 3**, restroom capacity was developed for the two planning horizons. **Table 4** summarizes the capacity calculation.

Table 4. Restroom Capacity Calculation

User	Existing			Year 2040		
	Stalls	Peak Load	Capacity	Stalls	Peak Load	Capacity
Male	5	19	40	4	33	32
Female	5	11	40	4	17	32

The results show the rest area is currently functioning well under design capacity at roughly 34%-59% of total peak period capacity. In the future (2040), the men’s restroom will meet peak period capacity and the women’s restroom will be at about 67% of peak capacity.

Finally, the lagoon system serving the rest area was also reviewed. The lagoon is in need of service repairs/relining by 2020. According to current data, the facility is currently operating (at peak season) well under capacity and should be able to accommodate the projected increase in users until 2040. At the time the rest area is expanded in the future, the lagoon system should be evaluated to determine if lagoon expansion is necessary to support future growth estimates.

FACILITY NEEDS

Through the facility assessments, meetings with SDDOT maintenance staff and future use calculations, a list of facility needs was developed. The needs address numerous issues found during the facility assessments including ADA compliance, building code conformity and overall functionality. These improvements were phased in five year horizons, starting with year 2020.

Concerning the ADA requirements, both site and building improvements will be required to make the facility and the restrooms accessible to the public per ADA minimum standards. The two following options were developed to provide modifications to the interiors to create sufficient access routes into the restrooms and to create wheelchair accessible stalls:

- This can be achieved by offsetting and widening the existing interior vestibules to the restrooms, and by converting a pair of toilet stalls to a single larger accessible stall. This upgrade approach will likely result in the loss of one men’s stall and two women’s stalls. This is the selected approach taken for this report as the facility is currently operating significantly under capacity.
- As an option, to avoid the loss of capacity (stalls), a larger project would be required. The restrooms could be expanded by an addition to the front of the building to include the vestibule and possible space for family restrooms as well. Given the limited lobby and general circulation aisles, this expansion approach has more long-term usability potential.

The following sections describe improvements to the facility in five year increments starting in year 2020 through year 2040:

Year 2020

The facility was constructed in 1973 and is need of a renovation to address ADA deficiencies and to upgrades and to refurbish components of the aging infrastructure. With this renovation the service life of the facility can be extended to 2040 when it will be nearing capacity, and will be ready for replacement. The following summarize the 2020 horizon improvements:

- Code Improvements (IBC 2012):

- Provide GFI power outlets and additional power outlets.
- Remove and replace storage areas not meeting 36" clearance near electrical panels.
- Provide standing drinking fountain for wheelchair accessibility.
- Update/replace information counters.
- Site required (ADA) Improvements
 - Re-grade rear parking lot to meet maximum allowable slope limitations, repave, restripe and provide new signs.
 - Provide improved/better directional signage from main parking lot.
 - Modify an additional exterior picnic bench for accessibility.
- Building (ADA) Improvements
 - Replace main entrance doors closer and hardware or provide entire new doors.
 - Provide new general interior signage to replace existing signs that meet current ADA standards.
 - Provide new public phone unit with sound control, TTY plug in, and shelf.
 - Reset soap dispensers above the lavatory counter. Locate a maximum of 44 inches above the floor.
 - Plan modifications for the restroom and restroom entries are required to provide for minimum interior clearances of the ADA. To achieve these requirements there are multiple options that could be considered by SDDOT to meet this and other needs. However, considering only ADA, as the facility is currently operating well under capacity, the lower cost alternatives below are recommended (note that this will be at the loss of 1 woman's stalls and 1 men's stall, and some lobby area). The proposed modifications are as follows:
 1. *Per ADA, where doors are provided wider aisle widths are required (52"-58).* Restroom entry doorways are too narrow at 36" and need to be widened with new partitions, doors, and hardware. *(As a temporary option, prior to construction, the actual doors could be removed to meet the ADA, which then only requires a minimum 36" corridor width (however there are ventilation, privacy and line of sight concerns).* This approach will require expansion internally into each restroom, possibly with the loss of a sink (leaving only one for each restroom). Also, note that, with this option, the information area sliding gate mechanism and door may have to be relocated further in as well.
 2. Each restroom has been retrofitted previously with 5' accessible stalls (at the loss of one stall for each restroom). They need to be properly modified with new partitions, handrails, properly placed accessories, and self-closing doors. Also, toilet locations should be adjusted to be between 16" & 18" from side partition.
 - Provide information counter modifications to accommodate an ADA user with the required clearances, heights, and hardware.
 - Widen and provide new access door between information area and storage/maintenance areas behind.

- Site Systems

- Provide lagoon system scheduled upgrades.
- Provide lagoon option to better address treated camper waste.
- Water pump repair/replacement.
- Replace the lawn irrigation system and all of its components including water pressure booster system.
- Replace Portable Storage sheds.
- Repair deteriorating joint seals.
- Repair pavement spalling and 5% of the panels.
- Replace 10% of the sidewalks.
- Seal cracks in asphalt (approximately 25% of area) and apply seal coat.
- Site and lighting allowance for minor improvements/repairs.
- Replace outdoor parking, building and pedestrian lighting with new energy efficient fixtures.
- Provide routine structural inspection and possible weld repairs on picnic shelters.
- Inspect roof structure supports.

- Parking

- Expand the existing truck parking area to accommodate 19 total parking spaces. Passenger vehicle parking will be relocated to the west side of the property, adjacent to the existing accessible parking spaces, and the existing lot will be reconfigured for truck parking only. This may require removal / relocation of the picnic area and shelters.

- Building System

- Replace failing information booth gate system.
- Renovate existing main facility including:
 - General exterior masonry minor repairs tuck-pointing, clean and seal.
 - Provide gutters and downspouts.
 - Repair and repaint trim and soffits.
 - Inspect and upgrade building insulation.
 - Provide insulating glass replacement storefront and window system.
 - Replace rear service doors and hardware.
 - General heavy cleaning, repair, and replace interior finishes including walls, ceilings, flooring, counters/cabinetry, and partitions.
 - Interior Paint and new flooring.

- Plumbing System

- Renovate plumbing, piping and fixtures:
- Replace water closets and urinals with vitreous china, wall hung water closets and wall hung urinals. Replace water closet and urinal flush valves with electronic type, hard wired units.
- Replace wall hung lavatory sinks with a multiple user lavatory station with composite solid surface construction and sensor type water outlets.
- Replace domestic water piping insulation.
- Provide bottle filler and piping that is not exposed to the elements.

- Mechanical System
 - Provide the following improvements to comply with Building Codes:
 - Operate exhaust air continuously or add motion sensor.
 - Install make up air units or energy recovery units.
 - Replace outdoor AC unit, include hail guards.
 - Replace the exhaust fan that serves the toilet rooms & grills.
- Electrical System
 - Replace outdated building interior lighting with new.
 - Replace the following:
 - Inspect and update Power System.
 - Replace existing electric hand dryers.
 - Replace existing CCTV system to provide remote monitoring of the facility.

Year 2025

Major improvements are not anticipated from year 2020 through year 2025. Annual maintenance allows facility to meet demand through the five year horizon.

Year 2030

- Site Systems
 - Provide additional concrete pavement panel replacement.
 - Replace additional 20% of sidewalks.
 - Replacement of asphalt shoulders and provide repairs to handicapped parking area.
 - Replace ramp, parking and pedestrian lighting.

Year 2035

Major improvements are not anticipated from year 2030 through year 2035. Annual maintenance allows facility to meet demand through the five year horizon.

Year 2040

By 2040 the facility will have reached the service life limits for both the facility and the site infrastructure. The facility will also be reaching capacity and will require an expansion of both the building and the parking areas. Given the extent of renovation projected, plus the costs of the addition, a new expanded 40 year replacement facility will be of better value at this time providing a new useful life goal to 2080.

COST ESTIMATE

A conceptual level planning cost for the improvements was developed for each horizon year. These costs estimates account for the installation of horizon year improvements (as stated previously), annual maintenance costs, and also include an SDDOT inflation factor of 4.43 percent per year. A Project Expense Cost of 20% was also added to provide for factors such as design fees, and SDDOT project costs. **Table 5** summarizes the horizon year cost estimates.

Table 5. Horizon Year Cost Summary

Component	Five-Year Horizon Cost				
	Year 2020	Year 2025	Year 2030	Year 2035	Year 2040
Exterior	\$868,000	\$0	\$462,000	\$0	\$7,575,000
ADA (site & building)	\$115,000	\$0	\$0	\$0	\$0
Building	\$353,000	\$0	\$0	\$0	\$2,160,000
Subtotal	\$1,336,000	\$0	\$462,000	\$0	\$9,735,000
Project Expenses	267,000	\$0	\$92,000	\$0	\$1,947,000
5yr Maintenance	\$329,000*	\$304,000	\$378,000	\$469,000	\$ 582,000
TOTAL	\$1,932,000	\$304,000	\$932,000	\$469,000	\$12,264,000

*7 year maintenance

Through year 2020, the site costs primarily include lagoon relining, paving modifications for ADA, pavement repairs, sidewalk repairs, replacement of irrigation system; lighting repairs. About one half the site costs budget includes a significant expansion of the truck parking area (including the relocation of the auto parking area to a new area, and possible modifications to of picnic area). Site structure repairs primarily include repairing of picnic shelters and portable storage sheds.

Building modifications include a complete renovation, and possibly a small family room & vestibule addition (which is not budgeted). If the recommended improvements are provided, except for paving the facility service life can be extended to year 2040 as well as the site infrastructure.

By year 2030, the site will require additional paving repairs (to extend the service life of paving and sidewalks to 2040), and outdoor lighting will need replacement.

By Year 2040 the construction of a newer, larger replacement facility will be of better value to SDDOT than the renovation of the existing. Also the site as a whole will require a significant reinvestment. It must be noted however, that the site size limitations may also limit possible future expansion of parking for the long-term.

CONCLUSION

In support of the Interstate Rest Areas Study, included is an analysis of the future needs at the Tilford East Rest Area. The purpose of the analysis is to quantify future needs at the rest area for five year planning horizons starting in year 2020.

The Tilford East Rest Area facilities as a whole, including the site infrastructure, auto parking, and the lagoon system are sufficiently sized to meet growth projections until 2040 with the exception of truck parking. Truck parking modifications, to permit long term growth, will require relocation of auto parking from the truck parking area to a new parking area including new access roads.

With respect to the long-term view, the overall condition of the main building is modest to poor. The facility at a minimum will need immediate ADA improvements, a new HVAC system, and a new lighting system and other upgrades. Within five to ten years, a more complete interior and exterior renovation will be required. The site is in good condition, but will require considerable repairs including the expansion of the truck parking area (and access) which is currently at capacity

The facility alone is small however it is sufficiently sized to accommodate long term growth projections. Given the extent of work immediately required, a general renovation is recommended

April 28, 2014 – Revised July 19, 2014
Memorandum to Brad Remmich
Page 8

as soon as possible. The project also may possibly require a small family room and vestibule addition however this is not included in the budget. By providing a complete renovation, the service life of the facility will be extended to 2040, when the facility will ready for replacement with a larger facility.

If you have any questions or need additional information regarding the conditions assessment feel free to contact Robert Morcom (MorcomRA@teamtsp.com) at TSP (605-343-6102).



April 28, 2014
REVISED July 19, 2014

MEMORANDUM

TO: Brad Remmich
SDDOT Transportation Planner

FROM: Timothy Roach, AIA
Jeremy Hahn, PE, PTOE

SUBJECT: SDDOT Interstate Rest Area Study
Technical Memorandum #4 – Tilford West Needs Assessment
FHU Reference No. 113039-01

In support of the Interstate Rest Areas Study, included is an analysis of the future needs at the Tilford West Rest Area. The purpose of the analysis is to quantify future needs at the rest area for five year planning horizons starting in year 2020. The following sections detail future use estimates at the rest area, and the improvements necessary to meet anticipated demand.

FUTURE USE CALCULATIONS

Determining the future use at each facility is based on the methodology contained in *Technical Memorandum #3-Parking Conditions Summary*. The analysis procedure estimated the growth in both passenger vehicles and truck traffic and developed long term parking estimates at each facility for the peak season. **Table 1** summarizes the growth in traffic estimated at the Tilford West facility.

Table 1. Parking Growth Estimates

User Type	Existing Parked Vehicles	Seasonal Factor	Year 2040 Growth Factor	Year 2040 Parked Vehicles
Passenger Vehicles	65	1.6	1.27	132
Trucks	45	1.6	2.4	173

The parking growth estimates show that passenger vehicle parking is anticipated to increase at an average rate of .89% per year, while truck parking would increase at a 3.08% yearly growth rate. Overall, the analysis indicates that daily users will significantly increase, and that the shift to servicing truck drivers, who are predominantly male, could drive the need for enhancing the men’s restroom facilities.

Using the previous parking projections, occupant load calculations were developed. A key factor is determining the number of occupants in each vehicle. In the memorandum *1992 Safety Rest Area Usage Survey Reports*, 1992, Minnesota Department of Transportation, a user survey of motorists at the Marion Rest Area in Minnesota identified an average of 2.3 persons per vehicle. For the

analysis, the 2.3 persons per vehicle occupancy rate has been applied only to passenger vehicles. In addition, it was assumed that the number of male and female occupants would be even.

Truck occupancy is anticipated to be far less, as most trucks have only a single driver. For purposes of this analysis, a 1.5 persons per vehicle occupancy rate was used for truck parking which accounts for tandem truck drivers and recreational vehicles. Currently, around 93% of truck drivers are male, but the number of female drivers is expected to increase in the future (<http://gobytrucknews.com/female-truckers-growing-in-number/>). To remain conservative, an 80/20 mix of male to female users was applied to the truck parking to account for an increase in female truck drivers and recreational vehicles which have a higher number of female passengers. **Table 2** provides a summary of the occupant load calculations at the rest area.

Table 2. Daily Occupant Load Summary

User	Existing Vehicles (@ Peak)	Year 2040 Vehicles	Occupancy Factor	Existing Occupants	Year 2040 Occupants
Passenger Vehicles	104	132	2.3 per/veh	239 (M=120, F=119)	304 (M=152, F=152)
Trucks	72	173	1.5 per/veh	108 (M=86, F=22)	260 (M=208, F=52)
Totals				347 (M=206, F=141)	564 (M=360, F=204)

M=Male
 F=Female

Peak period use of the facilities was derived from hourly parking occupancy rates contained in the Parking Conditions memorandum. By analyzing the 24-hour parking occupancy percentages of both passenger vehicles and trucks in the Parking Conditions memorandum (see parking occupancy graphs: *Technical Memorandum #3 – Parking Conditions Summary*), the peak hour use of the facility can be determined for the existing and year 2040 horizons. **Table 3** summarizes the peak occupant loading of the facility.

Table 3. Peak Hour Occupant Load Summary

User	Existing Conditions	Year 2040 Conditions
Male	18	33
Female	11	17

The results show that occupant loads during a typical day are expected to double between now and year 2040 at the Tilford West Rest Area. In addition, peak hourly use of the facility is also expected to increase significantly between now and year 2040.

Using the occupant load estimates, an estimate on capacity of restrooms was developed. It was assumed that the design capacity of one toilet is eight persons per stall per hour. In addition, the existing rest area provides a total of five men’s and women’s toilets each, and it was assumed that in the future one toilet would be removed from each rest room to meet ADA requirements. Using the total number of toilets and peak hour occupant load estimates from **Table 3**, restroom capacity was developed for the two planning horizons. **Table 4** summarizes the capacity calculation.

Table 4. Restroom Capacity Calculation

User	Existing			Year 2040		
	Stalls	Peak Load	Capacity	Stalls	Peak Load	Capacity
Male	5	18	40	4	33	32
Female	5	11	40	4	17	32

The results show that the rest area is currently functioning well under design capacity at roughly 37%-57% of total peak period capacity. By 2040, the men’s restroom will meet peak period capacity and the women’s restroom will be at about 56% of peak capacity.

Finally, the lagoon system serving the rest area was also reviewed. Based on a review of the existing as-built plans for the rest area and historical maintenance logs, the lagoon is in need of service repairs/relining by 2020. According to current data, the facility is currently operating (at peak season) well under capacity and should be able to accommodate the projected increase in users until 2040. At the time the rest area is expanded in the future, the lagoon system should be evaluated to determine if lagoon expansion is necessary to support future growth estimates.

FACILITY NEEDS

Through the facility assessments, meetings with SDDOT maintenance staff and future use calculations, a list of facility needs was developed. The needs address numerous issues found during the facility assessments including ADA compliance, building code conformity and overall functionality. These improvements were phased in five year horizons, starting with year 2020.

Concerning the ADA requirements, both site and building improvements will be required to make the facility and the restrooms accessible to the public per ADA minimum standards. The two following options were developed to provide modifications to the interiors to create sufficient access routes into the restrooms and to create wheelchair accessible stalls:

- This can be achieved by offsetting and widening the existing interior vestibules to the restrooms, and by converting a pair of toilet stalls to a single larger accessible stall. This upgrade approach will likely result in the loss of one men’s stall and two women’s stalls. This is the selected approach taken for this report as the facility is currently operating significantly under capacity.
- As an option, to avoid the loss of capacity (stalls), a larger project would be required. The restrooms could be expanded by an addition to the front of the building to include the vestibule and possible space for family restrooms as well. Given the limited lobby and general circulation aisles, this expansion approach has more long-term usability potential.

The following sections describe improvements to the facility in five year increments starting in year 2020 through year 2040:

Year 2020

The facility was constructed in 1973 and is need of a significant renovation to provide ADA upgrades and to refurbish the mostly original infrastructure. With this renovation the service life of the facility can be extended to 2040 when it will be nearing capacity, and will be ready for replacement. The following summarize the 2020 horizon improvements:

- Code Improvements (IBC 2012):
 - Provide GFI power outlets, and additional power outlets.
 - Remove and replace storage areas not meeting 36" clearance near electrical panels.
 - Provide standing drinking fountain for wheelchair accessibility.
 - Update/replace information counters.

- Site required (ADA) Improvements
 - Re-grade rear parking lot to meet maximum allowable slope limitations, repave, restripe and provide new signs.
 - Replace parking signs.
 - Provide improved/better directional signage from main parking lot.
 - Modify an additional exterior picnic bench for accessibility.

- Building (ADA) Improvements
 - Replace main entrance doors closer and hardware or provide entire new doors.
 - Provide new general interior signage to replace existing signs that meet current ADA standards.
 - Provide new public phone unit with sound control, TTY plug in, and shelf.
 - Reset soap dispensers above the lavatory counter, to a maximum height of 44 inches above the floor.
 - Plan modifications for the restroom and restroom entries are required to provide for minimum interior clearances of the ADA. To achieve these requirements there are multiple options that could be considered by SDDOT to meet this and other needs. However, considering only ADA, as the facility is currently operating well under capacity, the lower cost alternatives below are recommended (note that this will be at the loss of 1 woman's stalls and 1 men's stall, and some lobby area). The proposed modifications are as follows:
 1. *Per ADA, where doors are provided wider aisle widths are required (52"-58).* Restroom entry doorways are too narrow at 36" and need to be widened with new partitions, doors, and hardware. *(As a temporary option, prior to construction, the actual doors could be removed to meet the ADA, which then only requires a minimum 36" corridor width (however there are ventilation, privacy and line of sight concerns).* This approach will require expansion internally into each restroom, possibly with the loss of a sink (leaving only one for each restroom). Also, note that, with this option, the information area sliding gate mechanism and door may have to be relocated further in as well.
 - 2 Each restroom has been retrofitted previously with 5' accessible stalls (at the loss of one stall for each restroom). They need to be properly modified with new partitions, handrails, properly placed accessories, and self-closing doors. Also, toilet locations should be adjusted to be between 16" & 18" from side partition
 - Information counter modifications are needed to accommodate an ADA user with the required clearances, heights, and hardware.

- Widen and provide new access door between information area and storage/maintenance areas behind.
- Site Systems
 - Provide lagoon system scheduled upgrades.
 - Provide lagoon option to better address treated camper waste.
 - Water pump repair/replacement.
 - Replace the lawn irrigation system and all of its components including water pressure booster system.
 - Replace portable storage sheds.
 - Repair deteriorating joint seals.
 - Repair pavement spalling and 5% of panels.
 - Replace 10% of the sidewalks.
 - Seal cracks in asphalt (approximately 25% of area) and apply seal coat.
 - Site and lighting allowance for minor improvements/repairs.
 - Provide routine structural inspection and weld repairs on picnic shelters.
- Parking:
 - Expand the existing truck parking area to accommodate 13 total parking spaces. Passenger vehicle parking will be relocated to the west side of the property, adjacent to the existing accessible parking spaces, and the existing lot will be reconfigured for truck parking only. This may require removal / relocation of the picnic area and shelters.
- Building System
 - Replace failing Information booth gate system.
 - Renovate existing main facility including:
 - General exterior masonry minor repairs tuck-pointing, clean and seal.
 - Provide gutters and downspouts.
 - Repair and repaint trim and soffits.
 - Inspect and upgrade building insulation.
 - Provide insulating glass replacement storefront & window system.
 - Replace rear service doors and hardware.
 - Provide general heavy cleaning and replace interior finishes including walls, ceilings, flooring, counters/cabinetry, and partitions.
 - Repaint interior and install new flooring.
 - Inspect roof structure supports.
- Plumbing System:
 - Replace water closets and urinals with vitreous china, wall hung water closets and wall hung urinals.
 - Replace water closet and urinal flush valves with electronic type, hard wired units.
 - Replace wall hung lavatory sinks with a multiple user lavatory station with composite solid surface construction and sensor type water outlets.
 - Replace domestic water piping insulation.
 - Provide bottle filler and piping that is not exposed to the elements.

- Mechanical System
 - Provide the following improvements to comply with Building Codes:
 - Operate exhaust air continuously or add motion sensor.
 - Install make up air units or energy recovery units.
 - Replace outdoor AC unit, include hail guards.
 - Replace the exhaust fan that serves the toilet rooms & grills.
 - Replace gas furnace with high efficiency gas furnace.

- Electrical System
 - Replace outdated building interior lighting with new.
 - Inspect and update the power system.
 - Replace existing electric hand dryers.
 - Replace existing CCTV system with new equipment that will allow remote monitoring of the facility.

Year 2025

Major improvements are not anticipated from year 2020 through year 2025. Annual maintenance allows facility to meet demand through the five year horizon.

Year 2030:

- Site Systems
 - Provide additional concrete pavement panel replacement.
 - Replace additional 20% of sidewalks.
 - Replacement of asphalt shoulders and provide repairs to handicapped parking area.
 - Replace ramp, parking and pedestrian lighting.

Year 2035

Major improvements are not anticipated from year 2030 through year 2035. Annual maintenance allows facility to meet demand through the five year horizon.

Year 2040

By 2040 the facility will have reached the service life limits for both the facility and the site infrastructure. The facility will also be reaching capacity and will require an expansion of both the building and the parking areas. Given the extent of renovation projected, plus the costs of the addition, a new expanded 40 year replacement facility will be of better value at this time extending the useful life goal to 2080.

COST ESTIMATE

A conceptual level planning cost for the improvements was developed for each horizon year. These costs estimates account for the installation of horizon year improvements (stated previously), annual maintenance costs and also include an SDDOT inflation factor of 4.43 percent per year. Also, A Project Expense Cost of 20% was added to provide for factors such as design fees, and SDDOT project costs. And, as the condition, type and cost of highway/ramp lighting is unknown at this point, a separate line item has been provided. **Table 5** summarizes the horizon year cost estimates.

Table 5. Horizon Year Cost Summary

Component	Five-Year Horizon Cost				
	Year 2020	Year 2025	Year 2030	Year 2035	Year 2040
Exterior	\$1,125,000	\$0	\$350,000	\$0	\$7,575,000
ADA (site & building)	\$115,000	\$0	\$0	\$0	\$0
Building	\$353,000	\$0	\$0	\$0	\$2,160,000
Subtotal	\$1,593,000	\$0	\$350,000	\$0	\$9,735,000
Project Expenses	\$319,000	\$0	\$70,000	\$0	\$1,947,000
5yr Maintenance	\$329,000*	\$304,000	\$378,000	\$469,000	\$582,000
TOTAL	\$2,241,000	\$304,000	\$798,000	\$469,000	\$12,264,000

*7 year maintenance

Through year 2020, the site costs primarily include lagoon relining, paving modifications for ADA, pavement repairs, sidewalk repairs, replacement of irrigation system; and lighting repairs. About one half the site costs budget includes a significant expansion of the truck parking area (including the relocation of the auto parking area to a new area, and possible modifications to of picnic area). Site structure repairs primarily include repairing of picnic shelters and portable storage sheds.

Building modifications include a complete renovation, and possibly a small family room & vestibule addition (which is not budgeted). If the recommended improvements are provided, the facility service life can be extended to year 2040 as well as the site infrastructure for the most part.

By year 2030, the site will require additional paving repairs (to extend the service life of paving and sidewalks to 2040) and outdoor lighting will need replacement.

By Year 2040 the construction of a newer, larger replacement facility will be of better value to SDDOT than the renovation of the existing. Also the site as a whole will require a significant reinvestment.

CONCLUSION

In support of the Interstate Rest Areas Study, included is an analysis of the future needs at the Tilford West Rest Area. The purpose of the analysis is to quantify future needs at the rest area for five year planning horizons starting in year 2020.

The Tilford West Rest Area facilities as a whole, including the site infrastructure, auto parking, and the lagoon system are sufficiently sized to meet growth projections until 2040 with the exception of truck parking. Truck parking modifications, to permit long term growth, will require relocation of auto parking from the truck parking area to a new parking area including new access roads.

With respect to the long-term view, the overall condition of the main building is modest to poor. The facility at a minimum will need immediate ADA improvements, a new HVAC system, and a new lighting system and other upgrades. Within five to ten years a more complete interior and exterior renovation will be required. The site is in good condition, but will require considerable repairs including the expansion of the truck parking area (and access) which is currently at capacity.

The facility alone is small, however, it is sufficiently sized to accommodate long term growth projections. Given the extent of work immediately required, a general renovation is recommended as soon as possible. The project also may possibly require a small family room and vestibule addition however this is not included in the budget. By providing a complete renovation, the service life of the facility will be extended to 2040, when the facility will be ready for replacement with a larger facility.

If you have any questions or need additional information regarding the conditions assessment feel free to contact Robert Morcom (MorcomRA@teamtsp.com) at TSP (605-343-6102).

Appendix E. Financial Analysis Results

This appendix includes the results of the financial analysis for six remaining rest areas in the study. Given the age and condition of all facilities in the study, SDDOT can minimize costs by reconstructing new facilities as soon as possible. Preserving existing facilities is expensive and SDDOT would financially benefit by instead investing in new facilities immediately. However, due to budget constraints, it is not feasible to suggest rebuilding all facilities at this time. Instead, these financial analyses enable SDDOT to consider the costs of deferring significant investments. The analysis for these rest areas utilizes the same assumptions used for Hidewood Northbound, which are repeated below.

Figure E-1. Assumptions for Present Value Calculations

Assumption		
Present value calculations		
Escalation rate	4.43%	per year
Discount rate	4.43%	per year
Annual increase in preservation plan costs	12%	per year
Cost of preservation through 2040*	\$5.8-\$7.0	million
New facility cost†	\$3.15	million
Maintenance costs		
Annual maintenance on a new facility	\$10,000	per year
Periodic reinvestments	8%	every 10 years
(percent of new facility cost)	15%	every 20 years

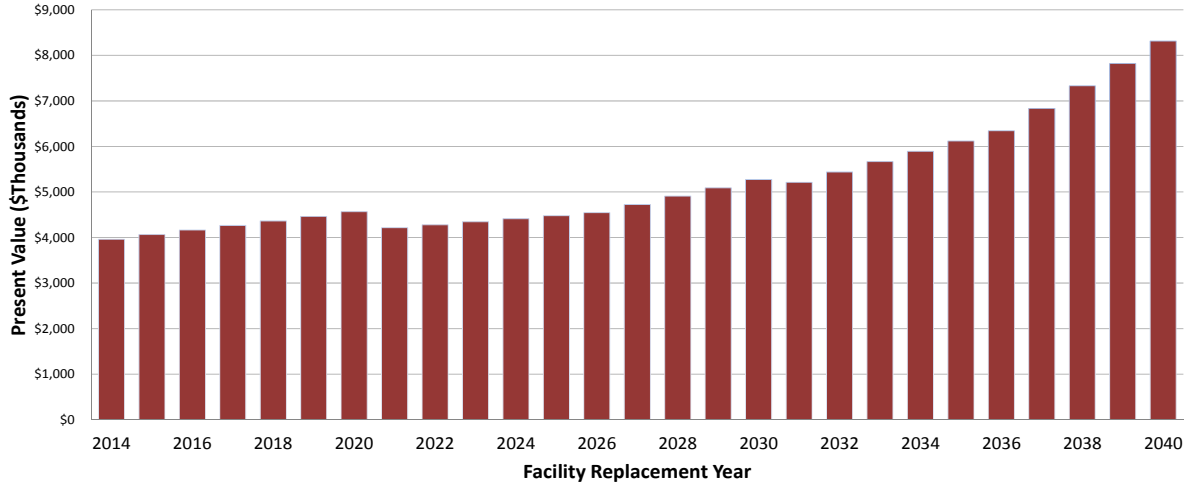
Note: *Preservation plans differ between rest areas.

†New facility cost for the Valley Springs POE is approximately \$2.7 million

Source: SDDOT, TSP, FHU, and BBC Research and Consulting, 2014.

The rest area at Hidewood Southbound is in similar condition to the Hidewood Northbound facility. While it is preferable to replace the facility as soon as possible, it is possible to preserve the facility until 2030 without incurring prohibitive costs; however after 2030 it becomes financially inefficient to continue making the necessary repairs. Between 2014 and 2030, SDDOT should consider reconstructing the Hidewood Southbound facility. The values of different repair plans are shown below in **Figure E-2**.

Figure E-2. Present Value of Repair Plans- Hidewood Southbound

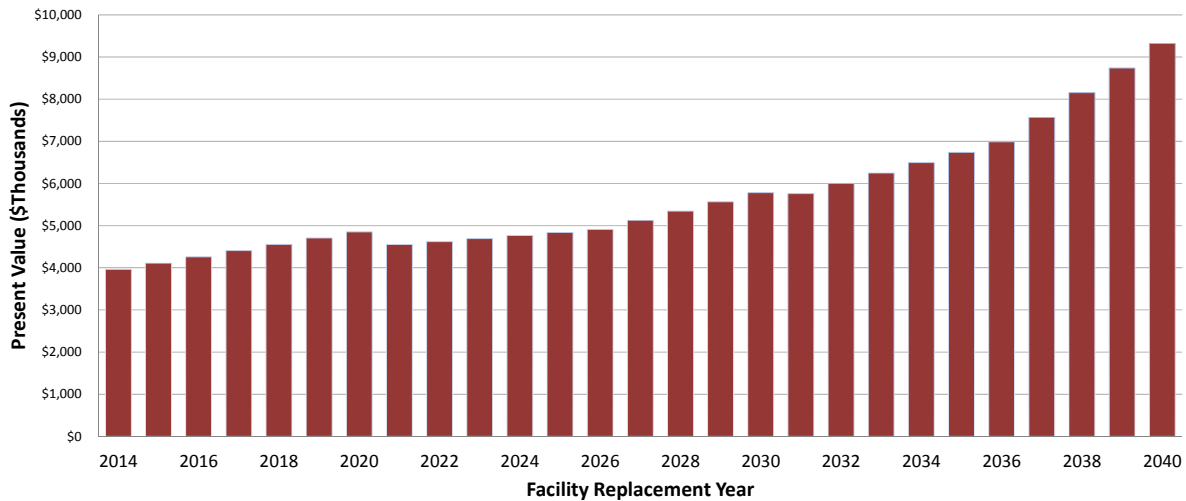


Note: Total present value of the preservation plan through 2040 is \$5.7 million, not including the value of a new facility.
 Source: TSP and BBC Research & Consulting. 2014

The Hidewood South rest area should be rebuilt before 2030 in order minimize future annual repair costs.

Costs for the Homestead rest area repair plans are shown in **Figure E-3**. Preserving this rest area is slightly more expensive than either Hidewood rest area.

Figure E-3. Present Value of Repair Plans- Homestead

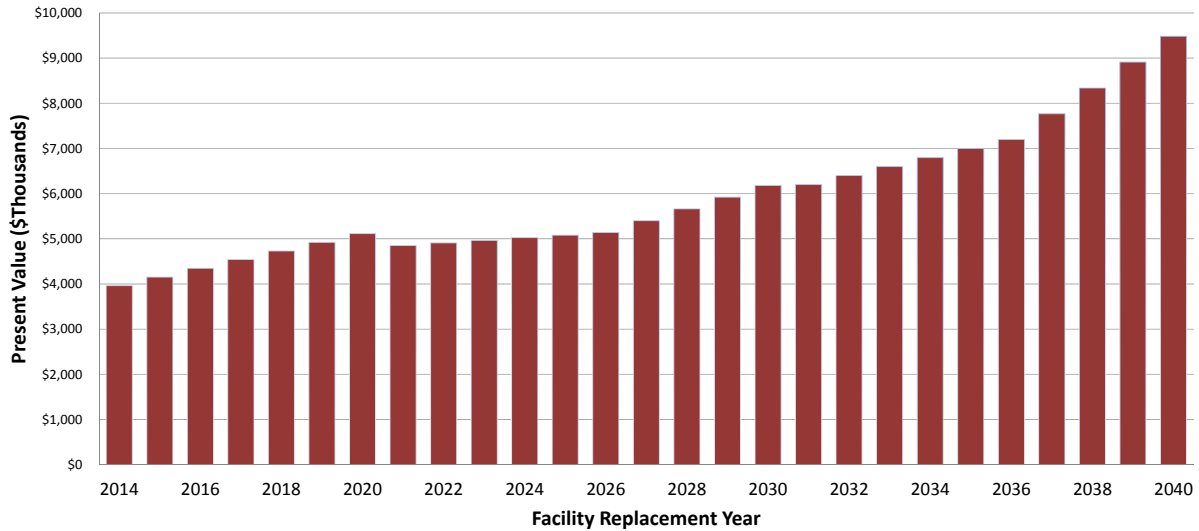


Note: Total present value of the preservation plan through 2040 is \$6.8 million, not including the value of a new facility.
 Source: TSP and BBC Research & Consulting. 2014

The Homestead rest area should be rebuilt as soon as possible, but preservation is still a viable option until approximately 2035. The facility will need to be rebuilt between 2035 and 2040.

Costs for the Tilford East rest area repair plans are shown in **Figure E-4**.

Figure E-4. Present Value of Repair Plans- Tilford East

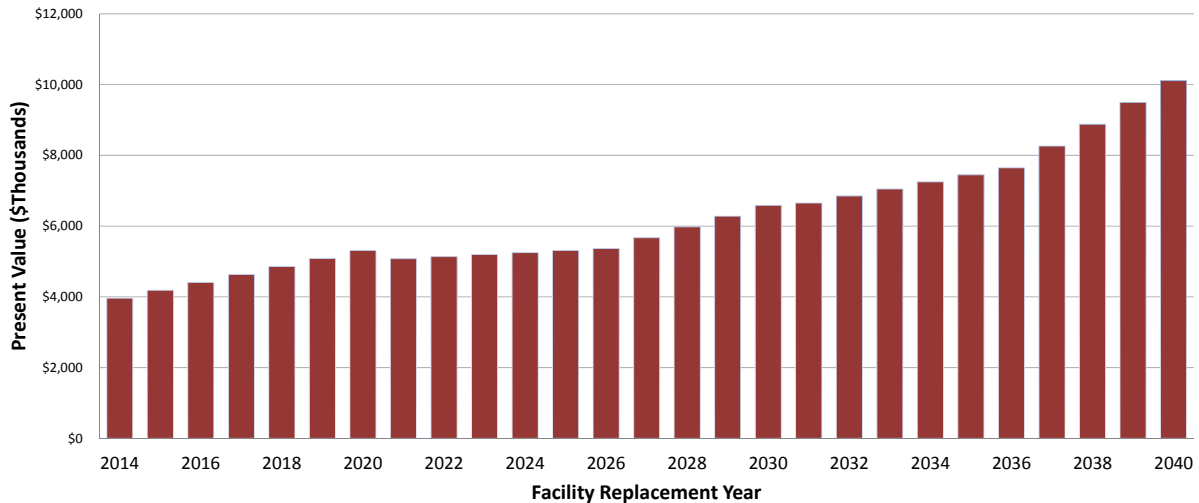


Note: Total present value of the preservation plan through 2040 is \$7.0 million, not including the value of a new facility.
 Source: TSP and BBC Research & Consulting. 2014

The Tilford East rest area is nearing the end of its useful life and should be rebuilt as soon as possible. However, the rest area can be preserved until approximately 2035 but it is advisable to rebuild the facility between 2035 and 2040.

Costs for the Tilford West rest area repair plans are shown in **Figure E-5**.

Figure E-5. Present Value of Repair Plans- Tilford West

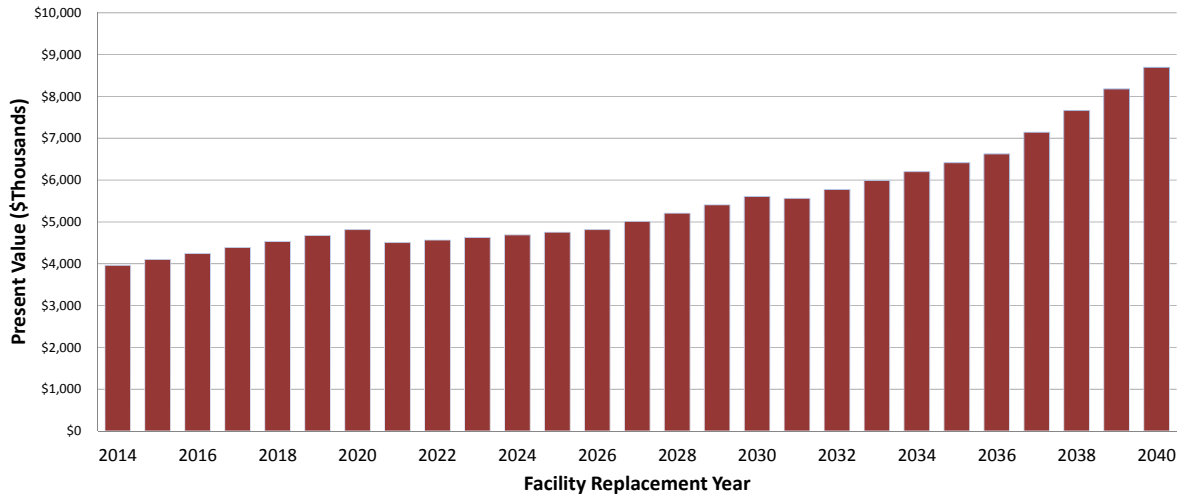


Note: Total present value of the preservation plan through 2040 is \$7.7 million, not including the value of a new facility.
 Source: TSP and BBC Research & Consulting. 2014

In order to minimize total costs, the Tilford West rest area should be rebuilt as soon as possible, however preservation can extend the useful life of the facility until approximately 2035.

Costs for the Valley Springs rest area repair plans are shown in **Figure E-6**.

Figure E-6. Present Value of Repair Plans- Valley Springs Rest Area

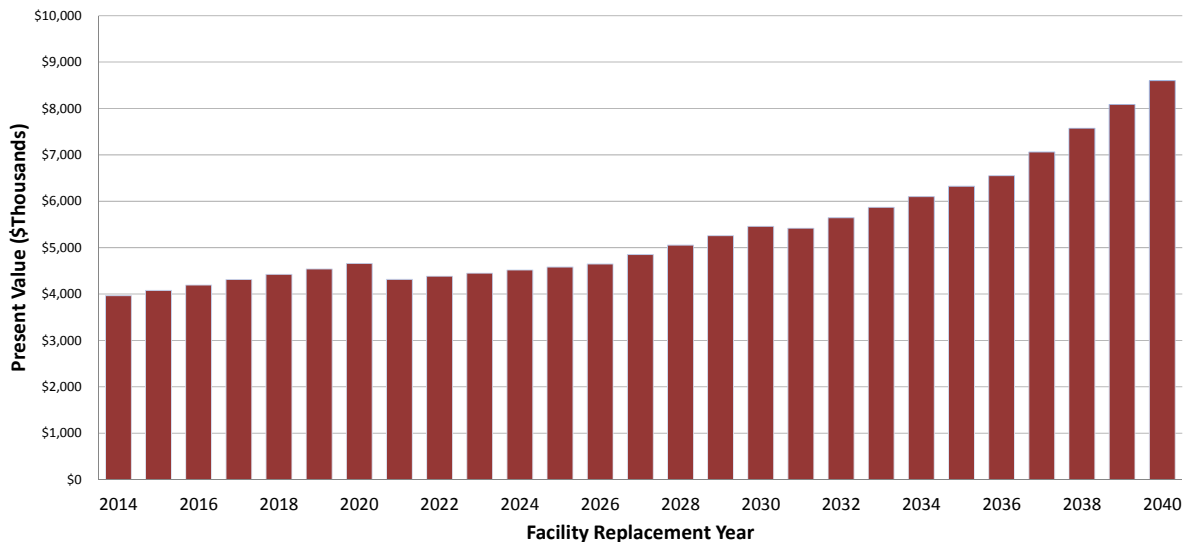


Note: Total present value of the preservation plan through 2040 is \$6.2 million, not including the value of a new facility.
 Source: TSP and BBC Research & Consulting. 2014

The Valley Springs rest area can be preserved until approximately 2035, but the facility should be reconstructed between 2035 and 2040.

The present value cost analysis for the Valley Springs point of entry facility is shown in **Figure E-7**. FHU estimates that it will cost approximately \$2.7 million to build a new POE facility.

Figure E-7. Present Value of Repair Plans- Valley Springs Point of Entry



Note: New facility cost for the Valley Springs POE is approximately \$2.7 million
 Total present value of the preservation plan through 2040 is \$6.8 million, not including the value of a new facility.
 Source: TSP and BBC Research & Consulting. 2014

The Valley Springs POE is approaching the end of its useful life, but preservation is still a financially viable option until approximately 2035. Repairs and maintenance can preserve the current facility until SDDOT makes decisions regarding future POE technology and functional space needs.